

LEVEL				MME DOC.:	MPE-007	20502	A
CONTROL VALVE				CLIENT DOC.:			
NO.	BY	APP	DATE	DESCRIPTION			
0	SES	IES	05/28/24	FOR APPROVAL			
1	DGJ	IES	07/03/24	FOR APPROVAL			

CLIENT DELTA 1
 P.O. NO.: PO-ENER-MME-2024-100-002
 PROJECT: BOC
 JOB NO.: MPE-007
 SERVICE: PROPANE REFERIGERATION PACKAGE

A. SELECTED VALVE DATA

MAYEKAWA VALVE SIZING CALCULATION

HYSIS SIMULATION

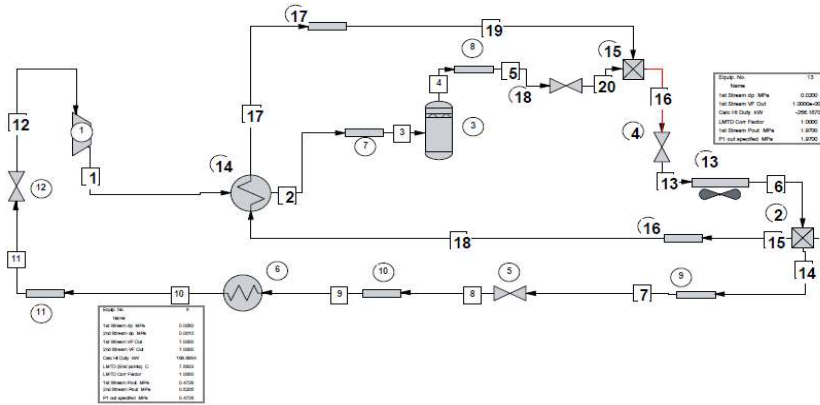

Stream No. 7

Name	
- - Overall - -	
Molar flow kmol/h	64.5523
Mass flow kg/h	2846.5000
Temp C	56.3228
Pres MPa	1.9682
Vapor mole fraction	0.0000
Enth kW	-2089.8
Tc C	96.6700
Pc MPa	4.2496
Std. sp gr. wtr = 1	0.508
Std. sp gr. air = 1	1.523
Degree API	147.2079
Average mol wt	44.0960
Actual dens kg/m3	436.7512
Actual vol m3/h	6.5174
Std liq m3/h	5.6067
Std vap 0 C m3/h	1446.8534
- - Vapor only - -	
Molar flow kmol/h	64.5523
Mass flow kg/h	2846.5000
Average mol wt	44.0960
Actual dens kg/m3	436.7512
Actual vol m3/h	6.5174
Std liq m3/h	5.6067
Std vap 0 C m3/h	1446.8534
Cp kJ/kg-K	3.5933
Z factor	0.0730
Visc cP	0.06919
Th cond Btu/hr-ft-F	0.0439
- - Liquid only - -	
Molar flow kmol/h	64.5523
Mass flow kg/h	2846.5000
Average mol wt	44.0960
Actual dens kg/m3	436.7512
Actual vol m3/h	6.5174
Std liq m3/h	5.6067
Std vap 0 C m3/h	1446.8534
Cp kJ/kg-K	3.5933
Z factor	0.0730
Visc cP	0.06919
Th cond Btu/hr-ft-F	0.0439
Surf. tens. dyne/cm	3.5382

HYSIS SIZING

Control Valve Sizing for Stream # 7

Loadings and Properties

	Vapor	Liquid
Flow rate	0.0000 kg/h	2846.5000 kg/h
Flow rate	0.0000 m3/h	6.5174 m3/h
Density	0.0000 kg/m3	436.7512 kg/m3
Total flow	2846.5000 kg/h	
Upstream pressure	1.9682 MPa	
Downstream pressure	0.4860 MPa	
Critical flow factor	0.9800	
Corr. factor for reducers	1.0000	
Static head	0.0000 mm	
Seat type	Single-Seat	
Flow type	Two phase flow	
Calc. coefficient Cvc	1.6216	
Capacity coefficient Cv	9.0000	
Cvc / Cv ratio	0.1802	
Valve size	1.0000 in	

VENDOR RECOMMENDED VALVE SIZE 1"/ANSI/CL300 IS ACCEPTABLE.