

Bill of Materials					
Item	Description	Size	Length (mm)	Material	Qty
1	Angle Support	L2x2x1/4	438.279	A242	2
2	Angle Support	L2x2x1/4	87.7037	A242	1
3	Angle Support	L2x2x1/4	341.594	A242	1
4	Angle Support	L2x2x1/4	477.067	A242	2
5	Angle Support	L2x2x1/4	526.405	A242	2
6	CS Flat Plate	1/4"	66 X 66	516 Gr.70	2
7	Bolt Set - SS	1/2"	55	A193-B8	1
8	Bolt Set - SS	3/4"	60	A193-B8	2

Please check with latest 3D model and make sure there is no discrepancy. Already this assembly is not match with Rev.0 Of 3D model

MME: THE SUPPORT IS IN LINE WITH THE LATEST 3D MODEL WHICH WILL BE FORWARDED SOON

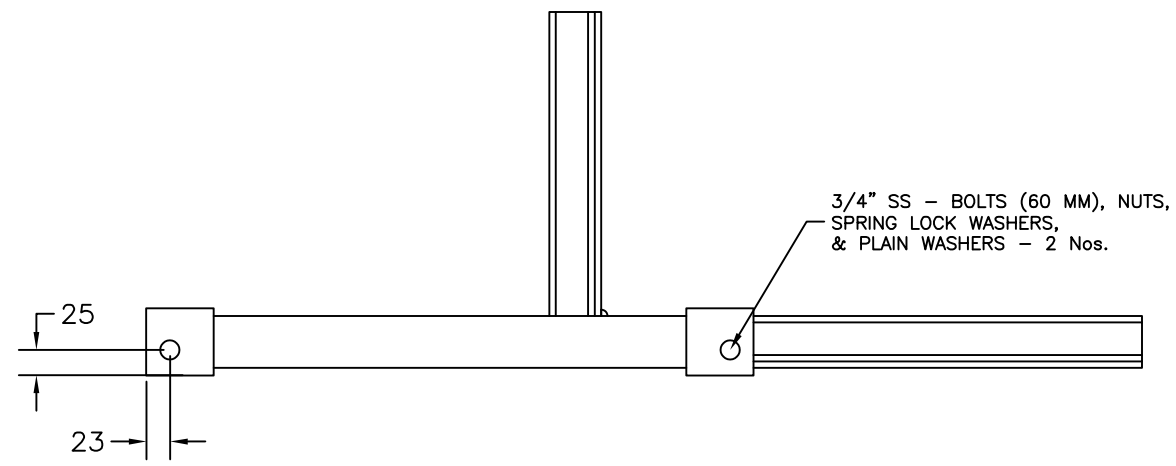
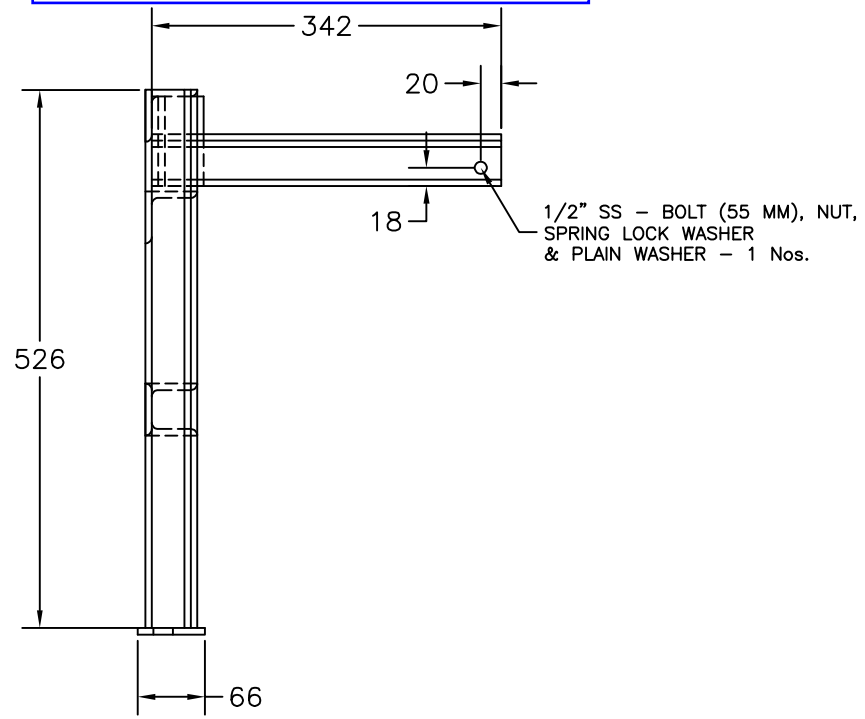
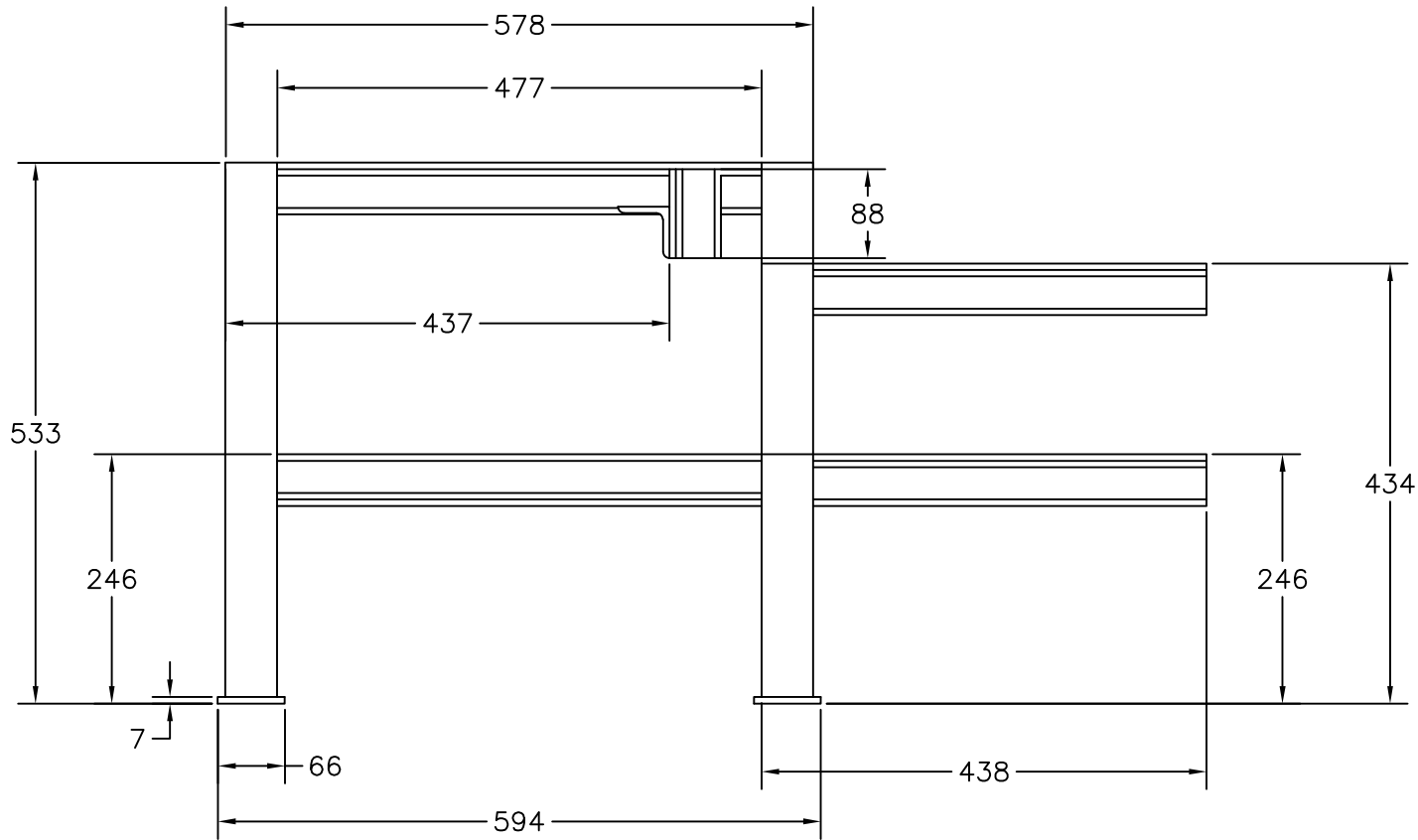
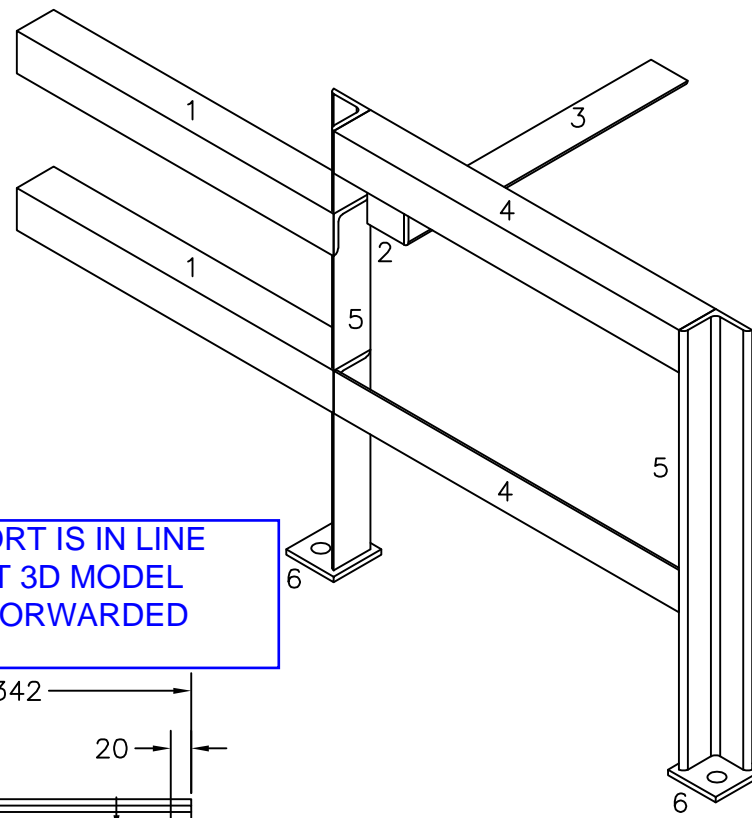

REV.	STATUS	DATE	PURPOSE OF ISSUE	PREP.	CHKD.	APPD.	AUTH.
0	F	29.07.24	FOR APPROVAL	AJD	AJD	IES	SES

CLIENT:	ENER TECHNOLOG		
SERVICE:	PROPANE REFRIGERATION PACKAGE		
LOCATION:	IRAQ		
UNIT TAG NO.:	RU-001 AB		
VENDOR LOGO			
Contract No.	P.O No. ENER-MME-2024-100-001		
SCALE			
DRAWING TITLE: SUPPORT FOR SLIDE VALVE ASSEMBLY			
DRAWING NO. MPE007- T0175-SPRT	REV. 0	SHEET No. 1 OF 1	SIZE D