



Toase-ehe Park Sanati Gohar Ofogh
Petrochemical Co.
**CONCEPTUAL, BASIC and DETAIL DESIGN
ENGINEERING OF STYRENE PARK OFFSITE**



Document Title: Chiller (Evaporator) Outline Drawing

Document No.: EI027-HSE-VD – ME– DWG– 008- R1

Rev. R1

Page 1 of 3

STYRENE PARK OFFSITE

Document Title:

Chiller (Evaporator) Outline Drawing

Rev.	Issued Date	DESCRIPTION	PREPARED	CHECKED	APPROVED
R1	08-07-2024	IFA	F.sh	M.O	A.M
R0	15-05-2024	IFA	F.sh	M.O	A.M



Toase-e Park Sanati Gohar Ofogh
Petrochemical Co.
**CONCEPTUAL, BASIC and DETAIL DESIGN
ENGINEERING OF STYRENE PARK OFFSITE**



Document Title: Chiller (Evaporator) Outline Drawing

Document No.: EI027-HSE-VD – ME– DWG– 008- R1

Rev. R1

Page 2 of 3

REVISION RECORD SHEET

Page Page	Revisions							Page	Revisions						
	R0	R1	R2	R3	R4	R5	R6		R0	R1	R2	R3	R4	R5	R6
1	X							41							
2	X							42							
3	X							43							
4								44							
5								45							
6								46							
7								47							
8								48							
9								49							
10								50							
11								51							
12								52							
13								53							
14								54							
15								55							
16								56							
17								57							
18								58							
19								59							
20								60							
21								61							
22								62							
23								63							
24								64							
25								65							
26								66							
27								67							
28								68							
29								69							
30								70							
31								71							
32								72							
33								73							
34								74							
35								75							
36								76							
37								77							
38								78							
39								79							
40								80							

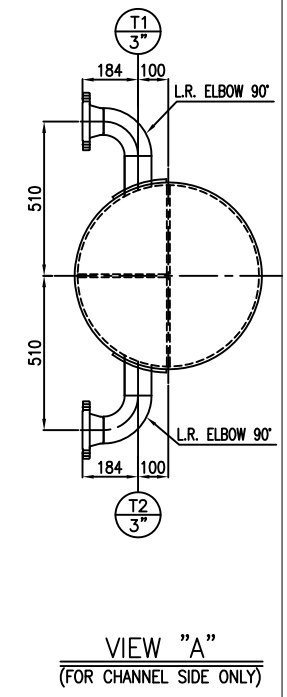
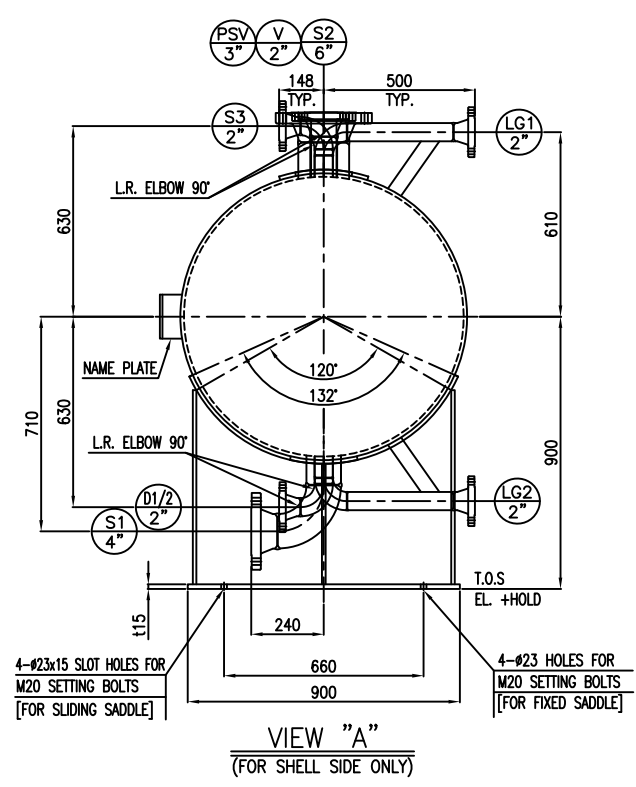
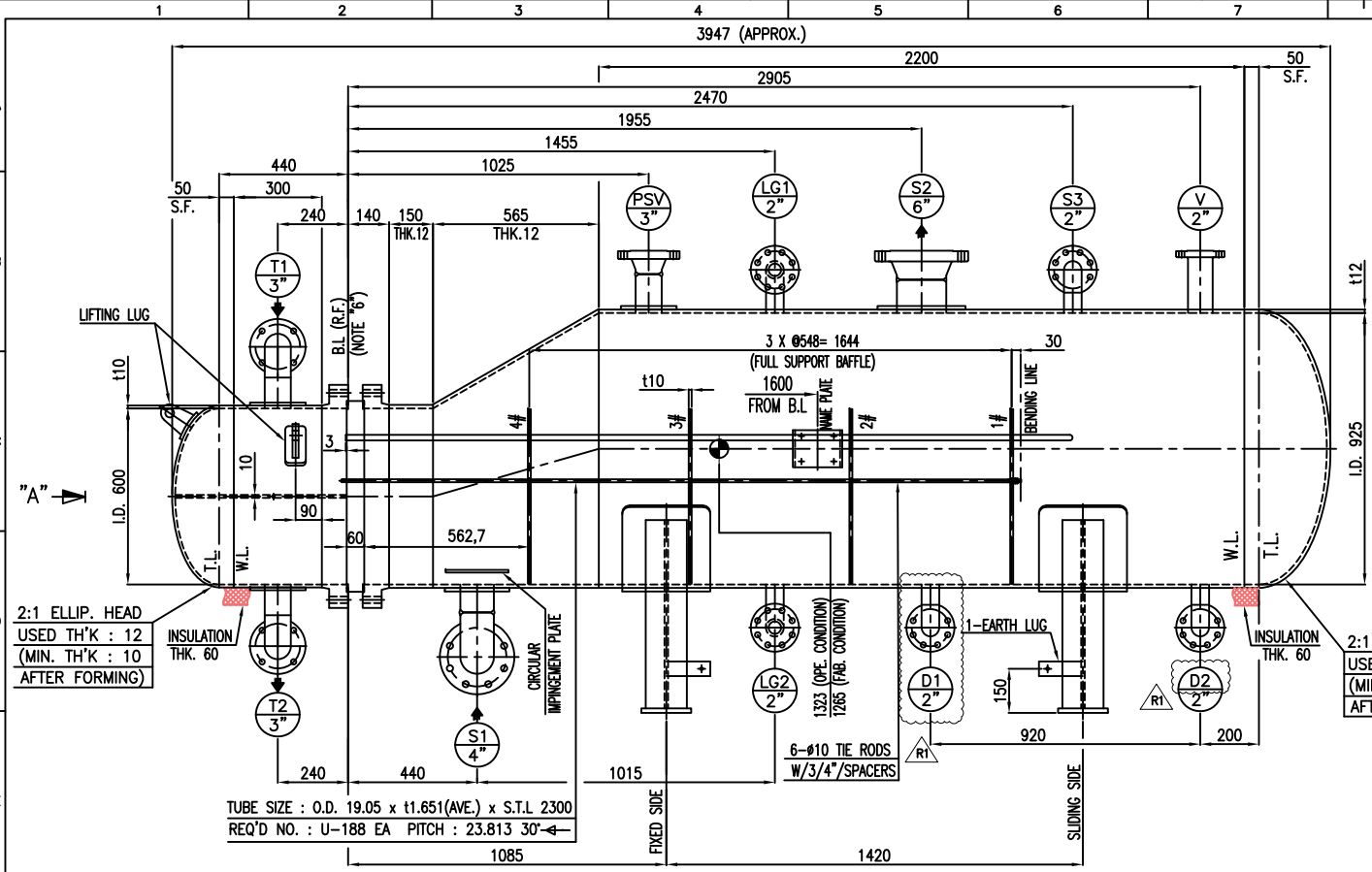

2:1 ELLIP. HEAD USED TH'K : 12 (MIN. TH'K : 10 AFTER FORMING)

INSULATION THK. 60

CIRCULAR IMPINGEMENT PLATE

1-EARTH LUG

132 (OPR. CONDITION) 1265 (PAB. CONDITION)

6-#10 TIE RODS W/3/4" SPACERS

INSULATION THK. 60

2:1 ELLIP. HEAD USED TH'K : 14 (MIN. TH'K : 12 AFTER FORMING)

TUBE SIZE : O.D. 19.05 x t1.651(AVE.) x S.T.L. 2300
REQ'D NO. : U-188 EA PITCH : 23.813 30'

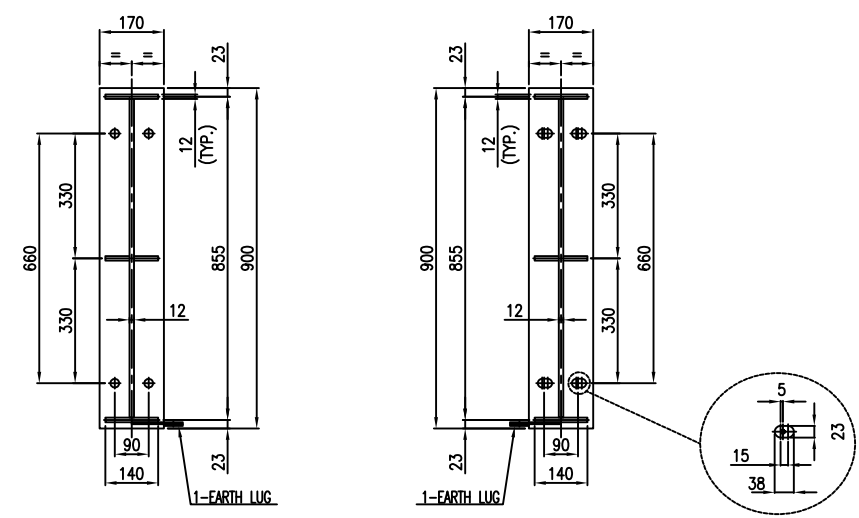

- NOTES
- UNLESS OTHERWISE NOTED ALL DIMENSIONS ARE IN MILLIMETERS.
 - UNLESS OTHERWISE NOTED OUTSIDE PROJECTION OF NOZZLES ARE MEASURED FROM C.L. OF EXCHANGER TO THE EXTREME FACE OF NOZZLE
 - ALL WELDS CONTINUOUS EXCEPT NOTED
 - BOLT HOLES FOR FLANGES SHALL BE STRADDLED TO EQUIPMENT MAIN AXIS
 - ALL R.F. FLANGES SHALL HAVE SMOOTH FINISH FACING WITH RA= 3.2mm TO RA= 6.3mm
 - BASE LINE (B.L.) INDICATES THE GASKET CONTACT SURFACE OF TUBE SHEET
 - REINFORCING PADS FOR NOZZLES SHALL BE TAPPED WITH AT LEAST ONE (1) TELL TALE HOLE NPT 1/4" WITH VENT PIPE.
-
- DIMENSIONS REFER TO BAFFLES ARE MEASURED FROM C.L. OF EACH PLATE
 - GASKET MATERIAL FOR ASME B16.20. SPIRAL WOUND (t4.5)
- FILLER: GRAPHITE
- INNER RING: 304 S.S.
- HOOP: 304 S.S.
- OUTER RING: 304 S.S.
 - GASKET MATERIAL: SPIRAL WOUND (t4.5)
- FILLER: GRAPHITE
- INNER RING: 304 S.S.
- HOOP: 304 S.S.
 - SPARE PART (OPTIONAL)
- | | CONSTRUCTION & COMMISSIONING |
|-------------------|------------------------------|
| GASKETS | 100% |
| STUD BOLTS & NUTS | 5% (MIN. 2SETS) |
- ALL EXPOSED SURFACE SHALL BE PAINTED AS FOLLOWS: EXPOSED SURFACE FOR EXTERNAL PARTS: E1027-HSE-VD-QC-PRO-002 EXPOSED SURFACE OF INTERNAL: NOT PARTS REQUIRED
 - 1/1.4 FACTOR FOR LOAD COMBINATION HAS BEEN APPLIED
 - TUBES SHALL BE SEAMLESS
 - GASKET CONTACT SURFACE OF TUBE SHEET & GIRTH FLANGE: RA= 1.6µm (MAX)
 - FURTHER DETAILS TO BE ADDED FOR DISCLAIMER PURPOSES SUCH AS AFTER HYDROTEST TO BE CLEANED AND DRIED.

REFERENCE DRAWING	DWG NO.	REV.
-	-	-

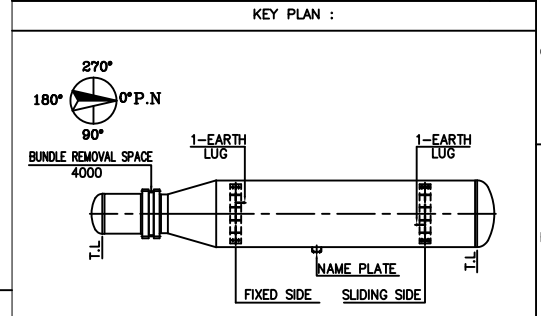

TABLE FOR FOUNDATION LOAD DATA

WIND		SEISMIC (NOTE 13)	
SHEAR (kgf)	MOMENT (kgf-m)	SHEAR (kgf)	MOMENT (kgf-m)
478	430	970	873

MATERIALS

SHELL		GENERAL	
BARREL	SA516-70N	SLIDING BAR/ROD	SA516 70/SA36
FLANGES	SA350-LF2 CL.1N	SEALING STRIP	SA516 70
NOZZLE FROM PIPE	SA333-6	DUMMY TUBE/SEAL ROD	-
NOZZLE FROM PLATE	SA516-70N	BLUNDED NOZZLE BOLT/NUT	SA320 L7/SA194-4
NOZZLE FLANGES	SA350-LF2 CL.1N	BLUNDED NOZZLE GASKET	SEE NOTE "9"
COUPLINGS & PLUGS	-	TEST RING	SA-266 2
NOZZLE REINF. PAD	SA516-70N	GASKETS	
EXCHANGERS SUPPORTS	SA283-C	SHELL/COVER	-
SUPPORT WEAR PLATE	SA516-70N	SHELL/TUBESHEET	SEE NOTE "10"
STIFFENING RINGS	SA516-70N	CHANNEL/TUBESHEET	SEE NOTE "10"
EXPANSION JOINT	-	CHANNEL/COVER	-
LINING	-	FLOATING HEAD	-
SHELL COVER		FLOATING HEAD	
BARREL	-	COVER	-
COVER	-	FLANGES	-
FLANGES	-	SPLIT RING	-
CHANNEL		BOLTS & NUTS	
BARREL	SA516-70N	SHELL/COVER	-
FLANGES	SA266-2N	SHELL/CHANNEL	SA320-L7/SA194-4
COVER	SA516-70N	CHANNEL/COVER	-
FLAT COVER	-	FLOATING HEAD	-
NOZZLE FROM PIPE	SA106-B	SETTING BOLTS/NUTS	SA193 B7 / SA194 2H
NOZZLE REINF.	SA516-70N	TUBE BUNDLE	
NOZZLE FLANGES	SA105N	TUBES	SA334-6
COUPLINGS & PLUGS	-	TUBESHEETS	SA350-LF2 CL1N
NOZZLE REINF. PAD	SA516-70N	BAFFLES/SUPPORTS/MP. PLATE	SA516-70
PARTITION PLATES	SA516-70N	TIE RODS & SPACERS	SA36/SA179

DESIGN DATA

CODE	ASME SEC. VIII DV.1 (2021 ED.)	TYPE	H-BKU
TEMA CLASS	TEMA 10TH ED. (CLASS "R")	CODE STAMP	NO
LOCAL REGULATION	NO	WIND / SEISMIC CODE	UBC 97
FLUID	PROPANE	STYRENE	WIND EXPOSURE / VELOCITY (km/h)
DESIGN (INT.EXT.)	PRESS. barg	22/F.V.	6.8
	TEMP. (°C)	120/85	85
	SEISMIC IMPROVANCE FACTOR/RESPONSE FACTOR	1.25 / 3	
	STEAM OUT CONDITION	-	-
	INSULATION (TYPE/THK.)	COLD/60	COLD/60
OPER. (IN/OUT)	PRESS. barg	3.813	4.5
	TEMP. (°C)	1.24/1	15.2/5
	FIRE PROOFING (mm)	-	-
	PAINTING	SEE NOTE "12"	
CORROSION ALLOWANCE (mm)	3	3	TUBE TO TUBESHEET JOINT
JOINT EFFICIENCY (S/H)	1.0/1.0	1.0/1.0	NEW EXPANDED WITH 2 GROOVES WITH SEAL WELD
	NO. OF PASS	1(ONE)	4(FOUR)
RADIOGRAPHY (S/H)	FULL/FULL	FULL/FULL	BUNDLE (KG)
HYDRO. TEST PRESS. (SHOP/FIELD)	barg	28.6/28.6	8.84/8.84
HYDRO. TEST TYPE	(U-900) NDE (B) (U-900) NDE (S)	WEIGHT	ERECTOR (KG)
PNEUM. TEST PRESS. barg	-		EMPTY (KG)
			OPER. (KG)
M.D.M.T. (°C)	-45	-29	FULL WATER (KG)
M.A.P (HOT & CORRODED) barg	22	6.8	SURFACE AREA/SHELL (M²)
M.A.P (NEW & COLD) barg	22	6.8	VOLUME (M³)
P.W.H.T	NO	NO	FLUID DENSITY (kg/m³)
IMPACT TEST	NO	NO	532.9
S.R. OF HEAD AFTER COLD FORMING	YES	YES	918.4
			MEAN METAL TEMP. (°C)
			-
			-
			SHELL SIDE TUBE SIDE

NOZZLE LIST

NOZZLE MARK	Q'TY / 1 SET	SIZE (INCH)	FLANGE RATING	SCH.	SERVICE	H/EX. CL. PROJECTION	REINF. PAD TH'K	O.D.
S1	1	4"	ASME B16.5 300# WN.RF	120	SHELL SIDE INLET	SEE DWG.	12	220
S2	1	6"	ASME B16.5 300# WN.RF	80	SHELL SIDE OUTLET	675	12	300
T1	1	3"	ASME B16.5 150# WN.RF	80	CHANNEL SIDE INLET	SEE DWG.	10	190
T2	1	3"	ASME B16.5 150# WN.RF	80	CHANNEL SIDE OUTLET	SEE DWG.	10	190
D1	1	2"	ASME B16.5 300# WN.RF	160	SHELL SIDE DRAIN	SEE DWG.	-	-
D2	1	2"	ASME B16.5 300# WN.RF	160	OIL RECOVERY	SEE DWG.	-	-
LG1	1	2"	ASME B16.5 300# WN.RF	160	LEVEL GAUGE	SEE DWG.	-	-
LG2	1	2"	ASME B16.5 300# WN.RF	160	LEVEL GAUGE	SEE DWG.	-	-
PSV	1	3"	ASME B16.5 300# WN.RF	160	PRESSURE SAFETY VALVE	675	12	190
V	1	2"	ASME B16.5 300# WN.RF	t16.6	VENT	675	-	-
S3	1	2"	ASME B16.5 300# WN.RF	160	SHELL SPARE/PURGE	SEE DWG.	-	-

LEGEND

B.L. = BASE LINE
C.L. = CENTER LINE
M.D.M.T. = MIN. DESIGN METAL TEMPERATURE
N. = NORMALIZED
O.T.L. = OUTER TUBE LINE
C.O.G. = CENTER OF GRAVITY
T.O.G. = TOP OF GROUTING
W.P. = WORKING POINT

REV.	ISSUE DATE	DESCRIPTION	PREPARED	CHECKED	APPROVED
R1	06.27.2024	ISSUED FOR APPROVAL (IFA)	D.SH.	M.O.	A.M.
R0	04.21.2024	ISSUED FOR APPROVAL (IFA)	D.SH.	M.O.	A.M.

CLIENT

CONSULTING ENGINEER

PROJECT: **STYRENE PARK OFFSITE**

DRAWING TITLE: **GENERAL ARRANGEMENT DRAWING FOR CHILLER (EVAPORATOR)**

DRAWING NO.	REV.	SCALE	SHEET
E1027-HSE-VD-ME-DWG-008	R1	A3	1 of 8