

- For continuous level measurement of liquids (even if polluted), mash and paste materials in open or closed vessels, sumps, open channels, drains, etc.
- Quick view measured values on the display
- Easy adjustment without measured material
- Elimination of false echoes
- Zone temperature compensation
- Possibility of using in explosive areas (version Xi)
- Current output (4 ... 20 mA) with HART® protocol or output RS-485 Modbus
- Copying of level meter configuration using display module DM-70
- While used with horn adapter can be measured also some difficult media (foamy levels, bulk solids, etc.)
- To mount the EMKOSONIC-60, you can use the VKD telescopic bracket, which can be found in the accessories.

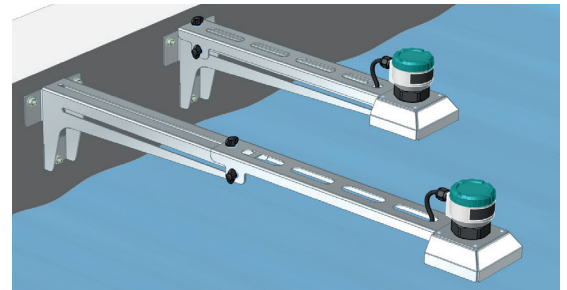

The **EMKOSONIC® ultrasonic level meters** are compact measurement devices including an electroacoustics converter, central processor unit and display module. Using the electroacoustics converter, the level meters transmit the sequence of ultrasonic pulses that spread towards the surface level. The converter recuperates reflected acoustic waves that are subsequently processed in the electronic module. The intelligent evaluation block filters out interfering signals, compares the cleaned received signal with the false reflection map (e.g. from mixers, ladders, reinforcement etc.) and selects a suitable reflection (echo). Based on the period during which the individual pulses spread towards the surface level and back and based on the measured temperature in the tank, the instant distance to the surface level is calculated. According to the level height, the level meter output is set: current 4-20 mA with HART® protocol or output RS-485 Modbus and the measured value is displayed on the display.

The level meters are suited to level measurement of various liquid materials, sewerage waters, mash and paste materials, suspensions in closed or open vessels, sumps, reservoirs and open channels. In case the level of bulk solids is measured, the measurement range is reduced. We recommend to consult the use with the manufacturer.

VARIANTS OF SENSORS

- **EMKOSONIC-60_-02** Measuring range from 0,15m do 2m, plastic PVDF transmitter and plastic body (PP+HDPE), process connection with thread G 1".
- **EMKOSONIC-60_-06** Measuring range from 0,25m do 6m, plastic PVDF transmitter and plastic body (PP+HDPE), process connection with thread G 1 ½".
- **EMKOSONIC-60_-10** Measuring range from 0.4m to 10m, plastic PVDF transmitter and plastic body (PP+HDPE), process connection with thread G 2 ¼".
- **EMKOSONIC-60_-20** Measuring range from 0.5m to 20m, with plastic PVDF transmitter and plastic body (PP+HDPE), aluminium alloy flange.

DIMENSIONAL DRAWINGS

EMKOSONIC-60_-02

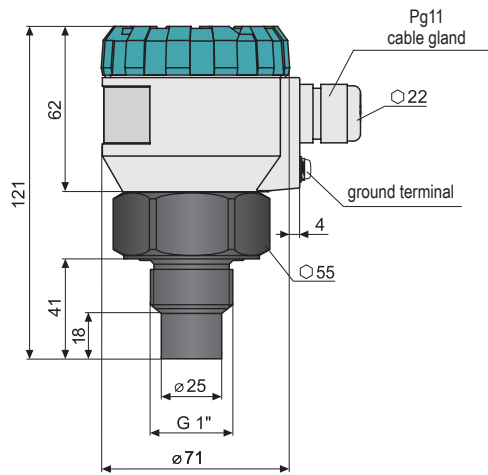

EMKOSONIC-60_-06

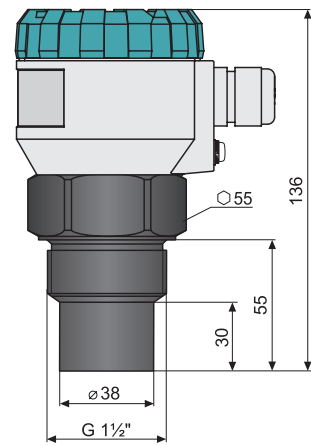

EMKOSONIC-60_-10

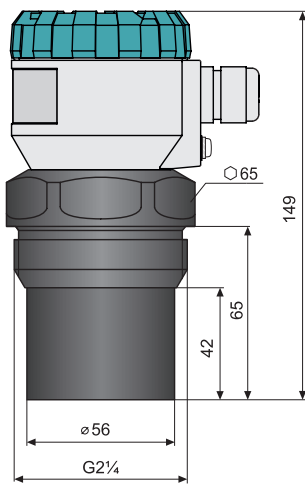

EMKOSONIC-60_-20

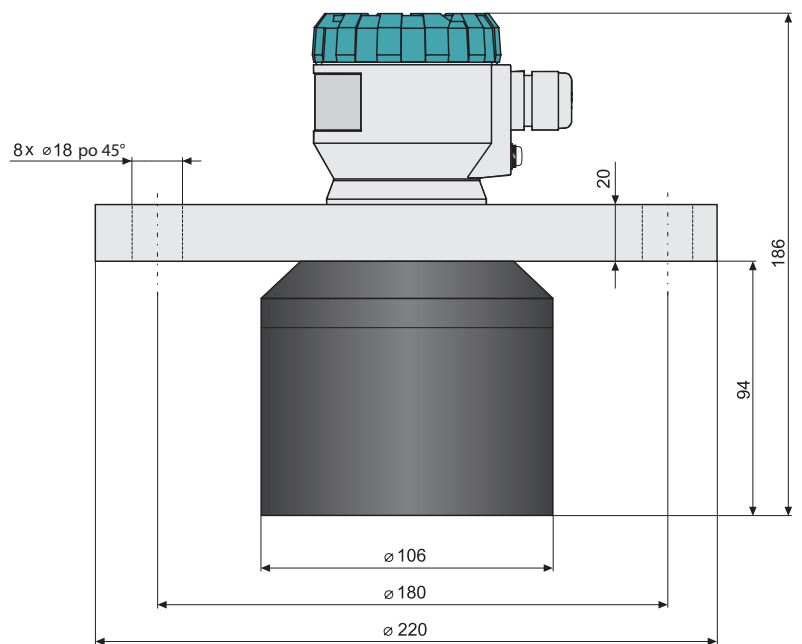

**variant EMKOSONIC-60
with protective conductor**

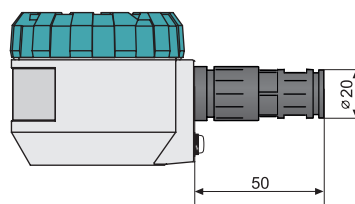

Flange (for type 20) according to standard: DIN 2527, PN10, DN100

TECHNICAL SPECIFICATIONS – LEVEL METER

Measuring range ¹⁾	EMKOSONIC-60_-02 EMKOSONIC-60_-06 EMKOSONIC-60_-10 EMKOSONIC-60_-20	0.15 ... 2 m 0.25 ... 6 m 0.4 ... 10 m 0.5 ... 20 m
Adjustable measuring range (SPAN)		Min. 200 mm
Supply voltage	EMKOSONIC-60_-__ EMKOSONIC-60Xi-__	18 ... 36 V DC 18 ... 30 V DC
Output	EMKOSONIC-60_-_-_-_-I EMKOSONIC-60_-_-_-_-M	4 ... 20 mA (Limit values 3.9 ... 20.5 mA), HART® RS-485 with protocol Modbus RTU
Current consumption	EMKOSONIC-60_-_-_-_-I EMKOSONIC-60_-_-_-_-M	4 ... 20 mA / Max. 22 mA Max. 20 mA
Resolution	EMKOSONIC-60_-02; 06 EMKOSONIC-60_-10 EMKOSONIC-60_-20	< 1 mm < 2 mm < 2,5 mm
Accuracy (within the total range)		0,15%
Temperature error		Max. 0,04% / K
Operating frequency	EMKOSONIC-60_-02 EMKOSONIC-60_-06 EMKOSONIC-60_-10 EMKOSONIC-60_-20	120 kHz 75 kHz 50 kHz 30 kHz
Beamwidth (-3 dB)	EMKOSONIC-60_-02; 10 EMKOSONIC-60_-06 EMKOSONIC-60_-20	10° 14° 12°
Ambient temperature range	EMKOSONIC-60_-02; 06 EMKOSONIC-60_-10; 20	-30 ... +70 °C -30 ... +60 °C
Short-time temperature stress resistance		+90 °C / 1 hod.
Max. operation overpressure (on transmission surface)		0,1 MPa
Sensitivity		3 stupně (low – medium – high)
Damping		0 ... 99 s
Measuring period		1 ... 4 s
Rise time		cca. 30 s
Additional technical data for Ex proof – Max. internal values		U _i =30V DC; I _i =132mA; P _i =0,99W; C _i =370nF; L _i =0,9mH
Failure indication (echo loss, level in dead zone ³⁾ , internal failure)		Adjustable in modes: 3.75 mA ; 22 mA ; Last measured value
Protection class		IP67
Mechanical connection	EMKOSONIC-60_-02 EMKOSONIC-60_-06 EMKOSONIC-60_-10 EMKOSONIC-60_-20	Screwing with thread G 1" Screwing with thread G 1½" Screwing with thread G 2¼" Aluminium alloy flange
Recommended cable	EMKOSONIC-60_-_-_-_-I EMKOSONIC-60_-_-_-_-M	PVC 2 x 0,75 mm ² PVC 2 x 2 x 0,25 mm ² (twisted pair, shielded)
Maximal resistance of current output load	U = 24 V DC U = 22 V DC U = 20 V DC U = 19 V DC	R _{max} = 270 Ω ²⁾ R _{max} = 180 Ω R _{max} = 90 Ω R _{max} = 45 Ω
Weight	EMKOSONIC-60_-02 EMKOSONIC-60_-06 EMKOSONIC-60_-10 EMKOSONIC-60_-20	0.3 kg 0.4 kg 0.7 kg 3.1 kg

¹⁾ In case the level of bulk-solid materials is measured, the measurement range is reduced.

²⁾ Including 250R resistor in case of HART connection.

TECHNICAL SPECIFICATIONS – DISPLAY MODULE

Type of display		matrix OLED, LCD ¹⁾
Resolution		128 x 64 pixels
Height of digits / Number of display digits of measured values		9 mm / 5 digits
Colour of display	OLED	yellow
	LCD	black with white background light
Type of buttons		membrane
Ambient temperature range	OLED	-30 ... +70 °C
	LCD	-20 ... +70 °C
Weight		46 g

¹⁾ OLED- suitable for indoor and low-light applications. LCD – suitable for outdoor applications particularly with direct sunlight.

USED MATERIALS

Sensor part	Variants	Standard material
Lid	All types	aluminium alloy with powder coating
Glass	All types	polycarbonate
Body	All types	aluminium alloy with powder coating
Housing with thread	All types	plastic PP
Electroacoustic converter	All types	plastic PVDF
Display module	EMKOSONIC-60_...-D (with display)	plastic POM
Cable gland	All types	plastic PA
Flange	EMKOSONIC-60-20-F	aluminium alloy with powder coating

AREA CLASSIFICATION (according to EN 60079-10 and EN 60079-14)

EMKOSONIC-60N-__	Performance for non-explosive areas
EMKOSONIC-60Xi-02 EMKOSONIC-60Xi-06	Explosive proof – suitable for explosive areas (combustible gases or vapours) ⊕II 1/2G Ex ia IIB T5 Ga/Gb with Isolating repeater (IRU-420), the whole level meter – zone 1, front head part – zone 0
EMKOSONIC-60Xi-10	Explosive proof – suitable for explosive areas (combustible gases or vapours) ⊕II 1/2G Ex ia IIA T5 Ga/Gb with Isolating repeater (IRU-420), the whole level meter – zone 1, front head part – zone 0
EMKOSONIC-60Xi-20	Explosive proof – suitable for explosive areas (combustible gases or vapours) ⊕II 2G Ex ia IIA T5 Gb with Isolating repeater (IRU-420), the whole level meter – zone 1

INSTALLATION

Level meter is installed into the upper lid of the tank (vessel), using a fixing nut or a flange.

If installed in an open channel (sumps, reservoirs, etc.), install the level meter as closest as you can to the maximum level expected.

The front of the level meter must be vertically to the measured level.

Foam on the level absorbs the acoustic wave reflection which might cause malfunction of the level meter. If possible select the location where the foaming is as low as possible.

Protect the level meter against direct sunlight.

In the case of uncertainty we recommend to consult the application with the producer.

MOUNTING RECOMMENDATION

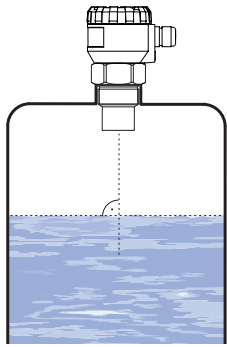

Recommended installation

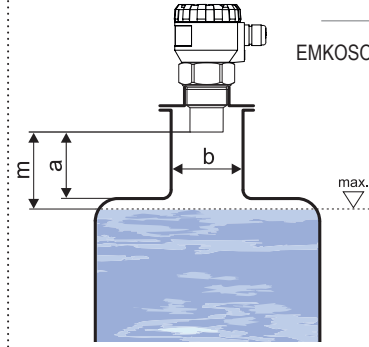

EMKOSONIC-60_02; 06	$a < 3b$ $b > 100 \text{ mm}$
EMKOSONIC-60_10	$a < 1,5b$ $b > 100 \text{ mm}$
EMKOSONIC-60_20	$a < 1,5b$ $b > 150 \text{ mm}$

a - neck height
b - neck width
m - dead zone

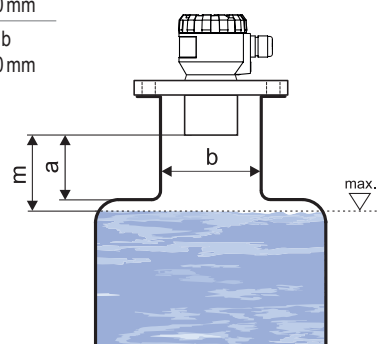

Possible installation through the neck

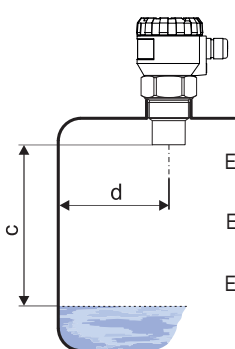

c - measuring range
d - min. distance from tank wall

EMKOSONIC-60_02; 10	$d > 1/12 c$ (min. 200 mm)
EMKOSONIC-60_06	$d > 1/8 c$ (min. 200 mm)
EMKOSONIC-60_20	$d > 1/10 c$ (min. 200 mm)

Installation distance from the tank wall

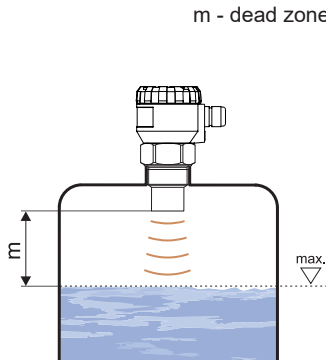

m - dead zone

Maximum level distance from EMKOSONIC

ELECTRICAL CONNECTION

The level meter is connected to consequential (evaluating) device with a suitable cable with the outer diameter of 6 to 8 mm using screw terminals located under the display module. The recommended cross section of cores for the current version $2 \times 0,5 \div 0,75 \text{ mm}^2$ and for the version with Modbus communication $2 \times 2 \times 0,25 \text{ mm}^2$ (twisted pair, shielded). Plus pole (+U) is connected to the terminal (+), minus pole (0V) to the terminal (-) and the shielding (only for shielded cables) to the terminal (\perp). Communication wires A and B of the line RS-485 (for version "M" - Modbus) are connected to the terminals A and B.

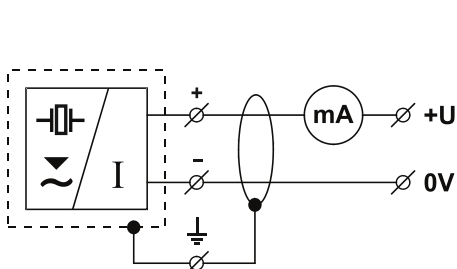

Wiring diagram of the level meter with current output EMKOSONIC-60_--_-I

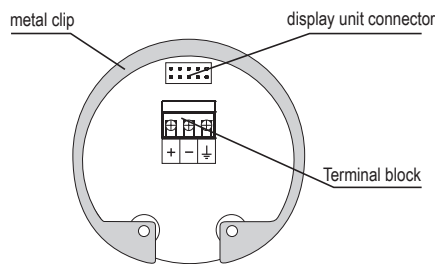

Inside view of screw terminals of the level meter with current output EMKOSONIC-60_--_-I

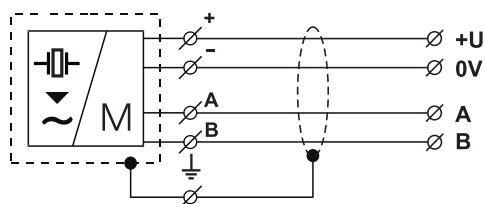

Wiring diagram of the level meter with Modbus EMKOSONIC-60_--_-M

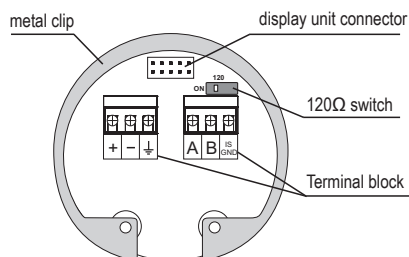

Inside view of screw terminals of the level meter with Modbus EMKOSONIC-60_--_-M

Electrical connection must be done in de-energized state!

The supply voltage source should be preferably realized as a stabilized power supply unit with safe voltage from 18 to 36 V DC ($18 \div 30 \text{ VDC}$ for Xi version), which can be a part of the evaluation or display device. With regard to possible occurrence of electrostatic charge on non-conductive parts of the level meter, all level meters for explosive spaces (EMKOSONIC-60Xi type) must be grounded. It will be done using a screw placed on the head of the level meter under the cable outlet. VIn case of strong electromagnetic interferences (EMI), parallel cable ducting with power lines, or when cable length exceeds 30 m we recommended to use shielded cable.

SETTING

Set the level meter using 3 buttons placed on the display module. All settings are accessible in the EMKOSONIC-60 set-up. For detailed mode access information please read at the instructions manual.

Button

- Set-up mode access
- Confirmation of selected item in the menu
- Move the cursor in the line
- Saving of set-up data

Button

- Move in the menu
- Change of values

Button

- Cancelling of carried out changes
- Shift one level up

* Slow flashing while the reflected signal (echo) is received from the measured level.

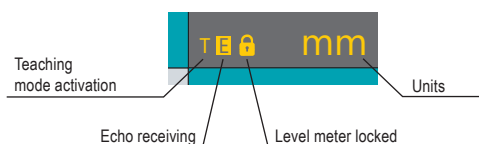
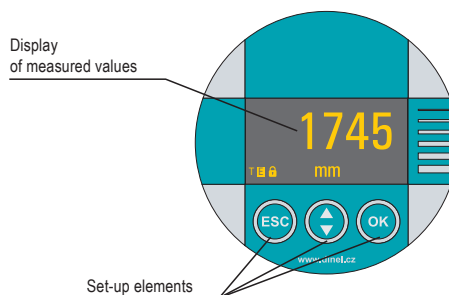

RANGE OF APPLICATIONS

For continuous non-contact level measurement of liquids (water solutions, sewerage water, etc.), mash and paste materials (sediments, sticks, resins etc.) in closed or open vessels, sumps, reservoirs and open channels. In case the level of bulk-solid materials is measured, the measurement range is reduced. We recommend to consult the use with the manufacturer

ORDER CODE

PRODUCT	
EMKOSONIC-60	
PERFORMANCE	
N	Normal – usable in non-explosive areas only
Xi	Ex. proof – suitable for explosive areas
MAXIMUM REACH	
02	0,15 ... 2 m, no F process connection can be selected
06	0,25 ... 6 m, no F process connection can be selected
10	0,4 ... 10 m, no F process connection can be selected
20	0,5 ... 20 m, no G process connection can be selected
PROCESS CONNECTION	
G	thread
F	flange
OUTPUT TYPE	
I	current output
M	RS-485 (Modbus RTU)
ELECTRICAL CONNECTION	
B1	plastic cable gland M16
B2	plastic cable gland M20
B3	plastic cable gland M20 for 2 cables
H1	outlet for protective conductor
SET-UP ELEMENTS	
D	basic version with OLED display
C	basic version with LCD display
L	without display, metal lid
EMKOSONIC-60 N - 06 - G - I - B1 - D	
EXAMPLE OF CODING	

CORRECT SPECIFICATION EXAMPLES

EMKOSONIC-60N-02-G-I-B-D EMKOSONIC-60N-10-M-H-L
 EMKOSONIC-60Xi-06-G-I-H-L EMKOSONIC-60Xi-20-F-I-B-D

ACCESSORIES

Standard – incl. in the price of the level sensor

- 1 pc of Seal (for EMKOSONIC-60_-02-I, 06-I)
- for version with Modbus software
Basic Scada Level is possible to download

Optional – for extra charge

- Fixing nuts G1" and G1 ½"
- Horn adapter ST-G1 and ST-G1,5
- for version with Modbus convertor URC-485

SAFETY, PROTECTION, COMPATIBILITY AND EXPLOSION PROOF

The level meter EMKOSONIC-60 is equipped with protection against reverse polarity and output current overload. Protection against dangerous contact is secured by low safety voltage that complies with EN 33 2000-4-41.

Electromagnetic compatibility according to EN 55022/B, EN 61326/Z1 and EN 61000-4-2 to 6.

Explosion proof of EMKOSONIC-60Xi type complies with the following standards: EN 60079-0 : 2007;

EN 60079-11 : 2007 ; EN 60079-26 : 2007 and examined by FTZÚ-AO 210 Ostrava - Radvanice certificate No.: FTZÚ 09 ATEX 0277X.

Special conditions for safe use EMKOSONIC-60Xi:

The device is designed for connection to the isolating repeater IRU-420. When the other approved supply unit is used, whose output parameters satisfy above mentioned output parameters, it is necessary to have a galvanic separation or, if supply unit without galvanic separation is used (Zener barriers), it is necessary provide potential equalization between sensor and point of barrier earthing.

For application in zone 0 the present explosive atmospheres - mixture of air with flammable gases, vapour or mists must comply: $0,8 \text{ bar} < p < 1,1 \text{ bar}$. The device must be installed in such a way, to prevent mechanical damage of sensor face. It is necessary carried out earthing by screw which is placed on head of level meter.