

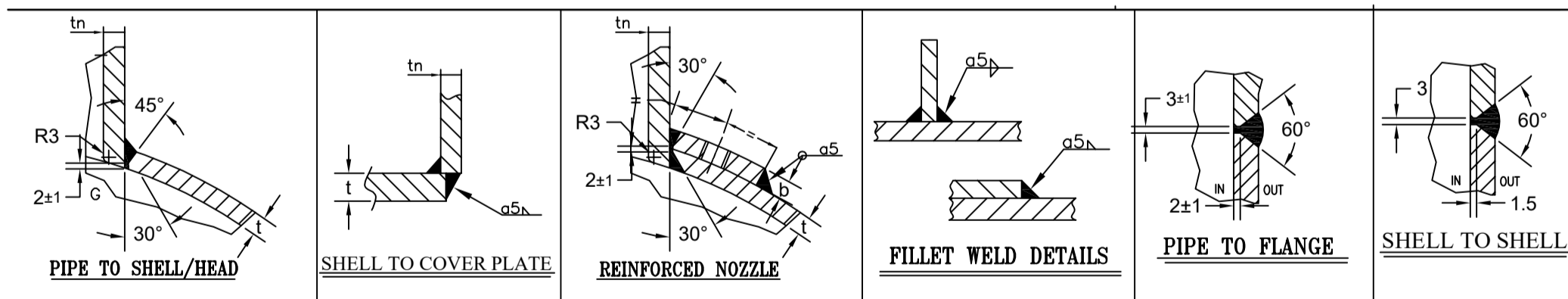

| JOINT NO. | JOINT SPEC. | VESSEL JOINTS | Process weld line | BASE METALS | | THICKNESS RANGE (mm) | WPS | PQR | VT | RT | PT | UT |
|-----------|----------------|------------------------------|-------------------|---------------|-------------|----------------------|--------|--------|------|-----|------|-----|
| | | | | SA516 Gr70N | SA516 Gr70N | | | | | | | |
| 1 | CWL-1 TO CWL-3 | SHELL TO SHELL | SMAW/GTAW | SA516 Gr70N | SA516 Gr70N | 5-20 | WPS 01 | PQR-01 | 100% | 10% | 100% | - |
| 2 | LW-1 TO LW-2 | SHELL TO SHELL | SMAW/GTAW | SA516 Gr70N | SA516 Gr70N | 5-20 | WPS 01 | PQR-01 | 100% | 10% | 100% | - |
| 3 | WL4 | PAD TO SHELL | SMAW/GTAW | SA516 Gr70N | SA516 Gr70N | 5-20 | WPS 01 | PQR-01 | 100% | - | 30% | - |
| 4 | WL5 | NOZZLE NECK TO FLANGE | SMAW/GTAW | SA 350 Gr.LF2 | SA 333 Gr.6 | 5-20 | WPS 03 | PQR-01 | 100% | 10% | 100% | - |
| 5 | WL6 | NOZZLE NECK TO SHELL OR HEAD | SMAW | SA 333 Gr.6 | SA516 Gr70N | 5-20 | WPS 02 | PQR-01 | 100% | - | 100% | 10% |
| 6 | WL-7 | FILLET WELD | SMAW | SA283 Gr.C | SA283 Gr.C | 5-20 | WPS 01 | PQR-01 | 100% | - | 10% | - |



| | | | | | | | |
|--|--|--|---------------|---------------|----------|----------------|---------------|
| PROJECT: STYRENE PARK OFFSITE | | REVISIONS | | | | | |
| | | 00 | 06-April-2025 | IFA | M.Y | S.D | S.D |
| | | NO. | DATE | DESCRIPTION | PREPARED | CHECKED | APPROVED BY |
| OWNER  پتروشیمی توسعه پارک صنعتی گوهر افق | VENDOR LOGO:  ARKAN SANAT PAYDAR | DWG. TITLE: NDT & WELDING MAP FOR RECEIVER HEADER(RU0001A/B-D-02) | | | | | |
| PHASE: | | DOCUMENT NUMBER: | | SIZE : | | REV. 00 | SCALE: |
| | | E1027-HSE-VD-ME-DWG-018 | | A4 | | SHT. 1 of 1 | - |