

Standard Compound Series unit component description

Capacity control	Two sets of 4 solenoid valves control the hydraulic unloader slide valves on low stage and high stage for capacity control. The low stage capacity is controlled between 0 and 100%, the high stage capacity between 20 and 100% (the 1612 high stage is always at 100%). Unloader indicator with 2 micro switches (0 and 100%) and potentiometer (0-1000 ohm).
Oil separation	Horizontal type oil separator with 2 separation stages, including: - frame for compressor and motor - oil heater (2000W; 400V) with thermostat - 2 oil level sight glasses Standard models are: HS6022C (1612C), HS7530C (2016), HS7533C (2520), HS10040C (3225).
● Primary separation	Gravity based oil separation in the shell of the oil separator.
● Secondary separation	High efficiency fine filter elements (design 5 ppm) are integrated in the second section of the oil separator. The number of elements is determined based on the compressor size and minimum & maximum operating conditions of the compressor.
Oil circuit	All necessary equipment & piping for lubrication, oil injection, oil draining and capacity regulation of the unit.
● Oil cooler	Standard with a thermo-siphon oil cooler. Alternatively with a water cooled oil cooler shell & tube type. Selection based on max. EG 30% refrigerant; Tin/Tout +35/40 °C. For different refrigerants and temperatures, consult the Mayekawa sales department.
● Oil filter	Double OFC-50 Mycom oil filter set with nylon filter elements (Rating: $\beta_{20} > 150$; Mesh: 15-20 μm). A triple oil filter set will be used if the total oil flow exceeds 300 l/min. Both can be isolated with a stop valve allowing filters to be changed when the unit is in operation.
● Oil pump	Mayekawa F50P/F60P type double helical gear oil pump with relief valve. Flanged motor for oil pump and flexible coupling type. M80P or M100P open type oil pump when required oil flow exceeds F50P/F60P capacity.
Suction side	SSD suction strainer housing with check valve to prevent backspin & gas flow back, counter flange on gas inlet.
● Suction filter	SSD Stainless steel strainer element (filtration grade 200 mesh, maximum particle size: 74 micron)
● Suction check valve	Duo check valve with steel seat.
Discharge side	Stop valve & safety valve dimensions based on the operating conditions of the compressor.
● Discharge check valve	Valve with stop & check function with counter flange on the gas outlet.
● Safety valve	Single (back pressure independent) safety valve on the oil separator.
Controls	MAYEKAWA Mypro-Touch microprocessor control panel.
● Control Panel	Mypro-touch controller offering a complete control and protection of the unit, easy parameter setting via simple keypad, monitoring on a 5,7" LCD display, alarm functions with logging, communication functions with other Mypro-Touch control panels or PLC/PC. (Optionally available are 7,5" and 12,1" displays)
● Gauges	63 mm gauges for suction, discharge and oil pressure mounted on the unit.
Main drive motor	Main drive motors are not included in the scope of supply of our compound
● Motor	2 pole direct drive method, B3 frame. The terminal box of the motor has an undrilled cable gland plate.
● Motor make	Mayekawa Europe cooperates with the following motor suppliers; ABB, Nidec, Siemens and WEG.

PLC will be considered for Complete skid S7-400

Main Motor and Oil Pump Motor will be Exec Suitable for Zone 2

● Coupling	Rexnord type coupling with flexible elements absorbing minor coupling misalignments and vibrations.	
● Alignment	Easy alignment is guaranteed on the non-flanged motors by means of adjustable motor support elements, pre-alignment done in MAYEKAWA EUROPE, final alignment to be done after installation at site.	
Painting	RAL 7035 epoxy painting on the unit (excluding motor). Average thickness: 120 microns.	
Economizer (option) See also section 5.2	<u>Open flash type</u>	<u>DX type</u>
● Heat exchanger	N.A.	Shell & tube heat exchanger with expansion set.
● Gauges	N.A.	In addition to the standard gauges (see above), a 63mm gauge for the intermediate pressure is mounted on the control panel.
● Control	Motor valve controlled by the Mypro-Touch control panel (if applicable).	Expansion set controlled by the Mypro-Touch control panel (if applicable).
● Gas return	Mayekawa standard open flash equipment according ME-SLS-I-0177.	Via intermediate check valve and gas strainer with connection to the compressor.
Included in delivery	<p>The scope of delivery includes:</p> <ul style="list-style-type: none"> - Unit fully assembled - Unit with complete cabling on the compressor unit - Pressure vessels with CE-PED approval according EN378: 2001 - Hydraulic pressure tested components - Pneumatic pressure tested unit - MAYEKAWA quality inspection - 1 year guarantee on manufacturing mistakes - Unit manual on CD 	
Not included in delivery (unless specified otherwise)	<p>The following items are not included:</p> <ul style="list-style-type: none"> - Motor starter / frequency inverter and cabling to main motor, pump motor & oil heater - Cable glands on the main motor and the pump motor - Marking for partial unit assembly acc. PED 2014/68 EU - Final motor alignment - Oil charge - Refrigerant charge - Thermal insulation - Commissioning at site - Spare parts recommended for commissioning / maintenance - Anchor bolts, lifting material (lifting lugs / spreader bars) - Unit packaging (shrink packaging / wooden crate) <div style="border: 1px solid red; padding: 5px; margin-top: 10px;"> <p>Instruments inside compressor skid will be fully as per MYCOM Standards, Documents for compressor skid also will be also limited to GA for compressor Skid and Compressor Package Datasheet, and PID</p> </div>	
Quality inspection	Quality inspection according to Mayekawa standard. The design and certificates based on CE & DMT/P	

The scope of supply is subject to change without prior notice

Compound Series compressor unit dimensions

PLC in safe area (control Room) will be considered instead

Main Motor and Oil Pump Motor with be Exec Suitable for Zone 2

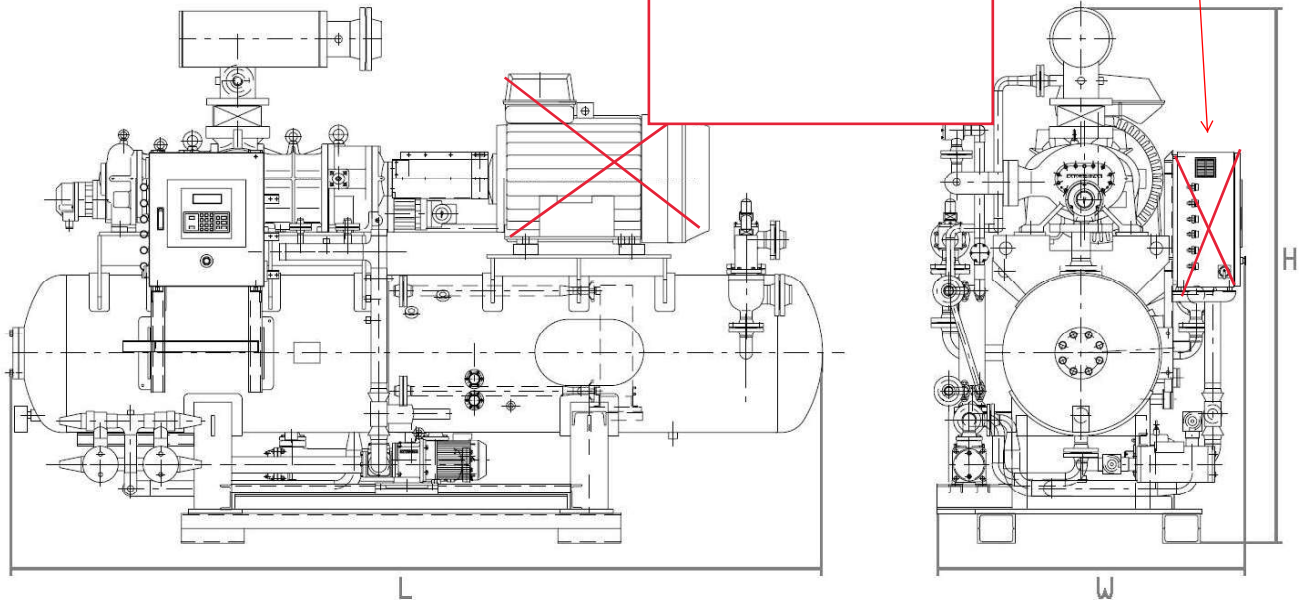

Dimensions are indicative.

Compound Models	Length (mm)	Width (mm)	Height (mm)	Provisional Weight (kg)
1612LSC-CPDDX-T	3500	1300	2000	4500
2016LSC-CPDDX-T	4000	1500	2600	5500
2520LSC-CPDDX-T	4500	1800	3000	8600
3225LSC-CPDDX-T	6000	2500	4200	21000

Notes:

- Heights are without transport profiles and with the suction strainers mounted. Transport arrangements should be made so that sufficient space is left for transport profiles which allow forklift handling. Suction strainers can be dismantled prior to shipping.
- The weight includes a typical size IP23 drive motor as reference.

The data can change depending on execution of the unit. The above data is an approximation based on reference units.

* Main drive motors are not included in the scope of supply of our compound type units