

- NOTES:
- FOR OPERATING AND DRY WEIGHTS, REFER TO ULT003-50098.
 - FOR CENTER OF GRAVITY, REFER TO ULT003-50098.
 - FOR DYNAMIC AND STATIC LOADS, REFER TO ULT003-50098.
 - FOR FOUNDATION DETAIL DRAWING, REFER TO ULT003-20021.
 - FOR LIFTING DETAILS, REFER TO ULT003-20011A.
 - FOR SKID INSTALLATION, REFER TO INSTRUCTION AND OPERATIONAL MANUAL ULT003-20092.
 - DIMENSIONS ARE IN INCHES AND MM IN PARENTHESIS.
 - ANCHOR HOLES TOLERANCES ± 0.13 in (± 3.2 mm).
 - BEAM LOCATION TOLERANCES: ± 0.13 in (± 3.2 mm).
 - NON-SKID GRATING UNDER MAINTENANCE AREA IS NOT INCLUDED.
 - SKID FLATNESS SHALL BE 0.0625" (1.6 mm).
 - SURFACE PREPARATION SHALL BE PER PROJECT PAINTING SPECIFICATION.
 - ANCHOR BOLT HOLES SHALL BE WITHIN THE SAME XY AND XZ PLANES WITHIN ± 0.13 in (± 3.2 mm).
 - COMPRESSOR SKIDS SHALL BE GROUTED. GROUT SPECIFICATION AND SELECTION BY OTHER AND SHALL BE SUITABLE TO PAINTING APPLICATION.

| | | | | | |
|---------------------------------|--|----|----|----|----|
| Code1 | <input type="checkbox"/> No Comment/ Approved (Applicable Only for "FOR REVIEW" and "For Approval" Documents) No comment and the document are released for Manufacturing | | | | |
| Code2 | <input type="checkbox"/> No Comment / Approved with Note(s) Vendor/Sub-Contractor shall correct, revise and resubmit the document. The document is released for Manufacturing if changes incorporated. | | | | |
| Code3 | <input type="checkbox"/> Commented Vendor/Sub-Contractor shall correct, revise and resubmit the document by the date specified. The document shall be reissued under the Status of "R: Revised Issue". All corrected documents shall be resubmitted before starting the Manufacturing Process | | | | |
| Code4 | <input type="checkbox"/> Not Accepted (Rejected) Vendor/Sub-Contractor shall re-work/re-design/re-specify the contents of the document according to the comments/reasons for rejection. All corrected documents shall be resubmitted before starting the manufacturing. Vendor Sub-Contractor shall not proceed with subsequent work of Material Supply or Manufacturing until receiving Code1/Code2 or No Code from PURCHASER. Vendor/Sub-Contractor shall resubmit the document with the same revision within 6 working days after receiving comments | | | | |
| No Code | <input type="checkbox"/> No Code (Only for "For Information" Documents and "As Built DWGs") Document has been submitted for PURCHASER'S information (I). Consistency, completeness and correctness of document content is in Vendor/Sub-Contractor's responsibility. The above checking result by EIED shall in no way relieve Vendor of any liability, obligation and responsibility out of the purchase order and the mutual agreement in writing | | | | |
| DATE : DEPT : Signature : | | | | | |
| CV | PI | EL | IN | ME | MA |
| ST | BU | PR | SA | HV | TL |

| | | | | | |
|---|--------------------|--|-----------|------------|----------|
| 00 | 28-06-2025 | IFR | FA | IM | OG |
| REV. | DATE (DD.MM.YY) | Purpose of Issue | Prepared | Checked | Approved |
| | | Gacharan Plymer Industries Company HDPE Plant | | | |
| CONTRACT NO.: GPI-CON-99-008 | | | | SCALE: 1:1 | |
| PO No.: xxxxxx | | | | | |
| DRAWING TITLE: General Arrangement Drawing (2D) (*Tie-In Points, Skid Dimensions & Orientation, Including Instrument, Junction Box and Local Panel Location Layout & Instrument Cable routing.) for Refrigerator Package | | | | | |
| DRAWING NO. VD-GPIC-MA-3029- 0062 | | REV. | SHEET NO. | SIZE | |
| | | 1 | OF 9 | A1 | |

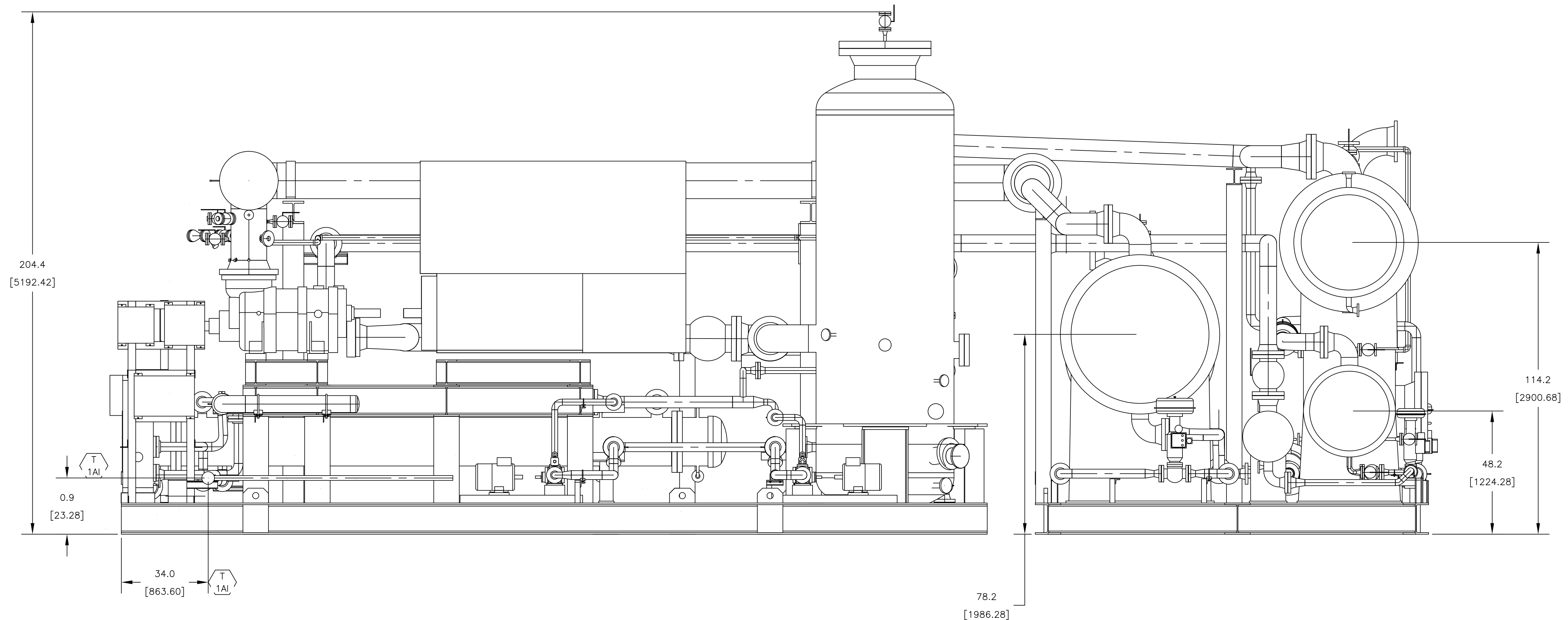

FRONT VIEW

| | | | | | |
|---------------------------------|---|----|----|----|----|
| Code1 | <input type="checkbox"/> No Comment/ Approved (Applicable Only for "FOR REVIEW" and "For Approval" Documents) No comment and the document are released for Manufacturing | | | | |
| Code2 | <input type="checkbox"/> No Comment / Approved with Note(s) Vendor/Sub-Contractor shall correct, revise and resubmit the document. The document is released for Manufacturing if changes incorporated. | | | | |
| Code3 | <input type="checkbox"/> Commented Vendor/Sub-Contractor shall correct, revise and resubmit the document by the date specified. The document shall be revised under the Status of "R: Revised Issue". All corrected documents shall be resubmitted before starting the Manufacturing Process | | | | |
| Code4 | <input type="checkbox"/> Not Accepted (Rejected) Vendor/Sub-Contractor shall re-work/re-design/re-specify the contents of the document according to the comments/reasons for rejection. All corrected documents shall be resubmitted before starting the manufacturing. Vendor Sub-Contractor shall not proceed with subsequent works of Material Supply or Manufacturing until receiving Code1/Code2 or No Code from PURCHASER. Vendor/Sub-Contractor shall resubmit the document with the same revision within 6 working days after receiving comments | | | | |
| No Code | <input type="checkbox"/> No Code (Only for "For Informator" Documents and "As Built DWG") Document has been submitted for PURCHASER'S Information (I). Consistency, completeness and correctness of document content is in Vendor/Sub-Contractor's responsibility. The above checking result by EIED shall in no way relieve Vendor of any liability, obligation and responsibility out of the purchase order and the mutual agreement in writing | | | | |
| DATE : DEPT : Signature : | | | | | |
| CV | PI | EL | IN | ME | MA |
| ST | BU | PR | SA | HV | TL |

| | | | | | |
|--|-----------------------|--|-----------|---------|----------|
| 00 | 28-06-2025 | IFR | FA | IM | OG |
| REV. | DATE (dd.MM.Yy) | Purpose of Issue | Prepared | Checked | Approved |
| | | Gachsaran Polymer Industries Company HDPE Plant | | | |
| CONTRACT NO.: GPI-CON-99-008 | | SCALE: 1:1 | | | |
| DRAWING TITLE: General Arrangement Drawing (2D) (*Tie-In Points , Skid Dimensions & Orientation, Including Instrument, Junction Box and Local Panel Location Layout & Instrument Cable routing.) for Refrigerator Package | | | | | |
| DRAWING NO. | VD-GPIC-MA-3029- 0062 | REV. | SHEET NO. | SIZE | |
| | | | 2 OF 9 | A1 | |

CONNECTION LIST

| NO. | LOCATION | DESCRIPTION | SIZE |
|--------|-------------------|----------------------------------|--------------------|
| T-1AI | COMPRESSOR SKID-A | INSTRUMENT AIR SUPPLY | 1"-150 ANSI RF |
| T-2AI | COMPRESSOR SKID-B | INSTRUMENT AIR SUPPLY | 1"-150 ANSI RF |
| T-4AI | VESSEL SKID | INSTRUMENT AIR SUPPLY | 1"-150 ANSI RF |
| T-3CWS | COMPRESSOR SKID-A | OIL COOLER COOLING WATER SUPPLY | 3"-300 ANSI RF |
| T-3CWR | COMPRESSOR SKID-A | OIL COOLER COOLING WATER RETURN | 3"-300 ANSI RF |
| T-4CWS | VESSEL SKID | OIL COOLER COOLING WATER SUPPLY | 10"-300 ANSI RF |
| T-4CWR | VESSEL SKID | OIL COOLER COOLING WATER RETURN | 10"-300 ANSI RF |
| T-41 | VESSEL SKID | FILTER/DRYER INLET | 2"-300 ANSI RF |
| T-51 | VESSEL SKID | CHILLER PROCESS INLET | 16"-300 ANSI RF |
| T-52 | VESSEL SKID | CHILLER PROCESS OUTLET | 16"-300 ANSI RF |
| S-31 | COMPRESSOR SKID-A | OIL SEPARATOR PRESSURE SAFETY | 4"-300 ANSI RF |
| S-41 | VESSEL SKID | CONDENSER PRESSURE SAFETY | 3"-300 ANSI RF |
| S-42 | VESSEL SKID | RECEIVER PRESSURE SAFETY | 4"-300 ANSI RF |
| S-43 | VESSEL SKID | ECONOMIZER PRESSURE SAFETY-SHELL | 1-1/2"-300 ANSI RF |
| S-44 | VESSEL SKID | ECONOMIZER PRESSURE SAFETY-TUBE | 1"-300 ANSI RF |
| S-51 | VESSEL SKID | CHILLER PRESSURE SAFETY | 4"-300 ANSI RF |

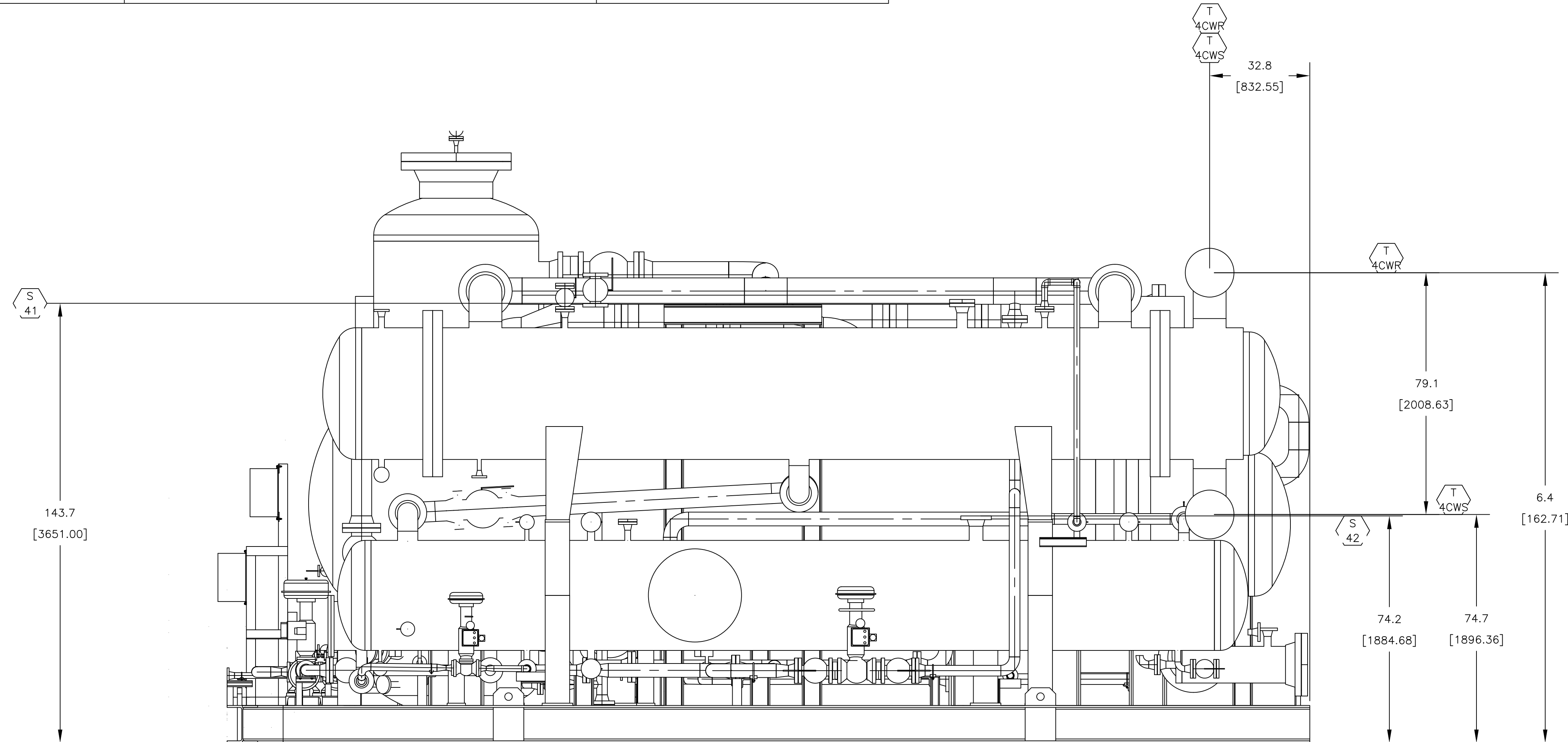

RIGHT VIEW

| | | | | | |
|---------------------------------|--|----|----|----|----|
| Code1 | <input type="checkbox"/> No Comment/ Approved (Applicable Only for "FOR REVIEW" and "For Approval" Documents) No comment and the document are released for Manufacturing | | | | |
| Code2 | <input type="checkbox"/> No Comment / Approved with Note(s) Vendor/Sub-Contractor shall correct, revise and resubmit the document. The document is released for Manufacturing if changes incorporated. | | | | |
| Code3 | <input type="checkbox"/> Commented Vendor/Sub-Contractor shall correct, revise and resubmit the document by the date specified. The document shall be revised under the Status of "R: Revised Issue". All corrected documents shall be resubmitted before starting the Manufacturing Process | | | | |
| Code4 | <input type="checkbox"/> Not Accepted (Rejected) Vendor/Sub-Contractor shall re-work/re-design/re-specify the contents of the document according to the comments/reasons for rejection. All corrected documents shall be resubmitted before starting the manufacturing. Vendor Sub-Contractor shall not proceed with subsequent work of Material Supply or Manufacturing until receiving Code1/Code2 or No Code from PURCHASER. Vendor/Sub-Contractor shall resubmit the document with the same revision within 6 working days after receiving comments | | | | |
| No Code | <input type="checkbox"/> No Code (Only for "For Information" Documents and "As Built DWGs") Document has been submitted for PURCHASER'S information (I). Consistency, completeness and correctness of document content is in Vendor/Sub-Contractor's responsibility. The above checking result by EIED shall in no way relieve Vendor of any liability, obligation and responsibility out of the purchase order and the mutual agreement in writing | | | | |
| DATE : DEPT : Signature : | | | | | |
| CV | PI | EL | IN | ME | MA |
| ST | BU | PR | SA | HV | TL |

| | | | | | |
|---|-----------------------|---|-----------|---------|----------|
| 00 | 28-06-2025 | IFR | FA | IM | OG |
| REV. | DATE (DD.MM.YY) | Purpose of Issue | Prepared | Checked | Approved |
| | | Gachsaran Plymer Industries Company HDPE Plant | | | |
| CONTRACT NO.: GPI-CON-99-008 | | SCALE: 1:1 | | | |
| DRAWING TITLE: General Arrangement Drawing (2D) (*Tie-In Points, Skid Dimensions & Orientation, Including Instrument, Junction Box and Local Panel Location Layout & Instrument Cable routing.) for Refrigerator Package | | | | | |
| DRAWING NO. | VD-GPIC-MA-3029- 0062 | REV. | SHEET NO. | SIZE | |
| | | | 3 OF 9 | A1 | |

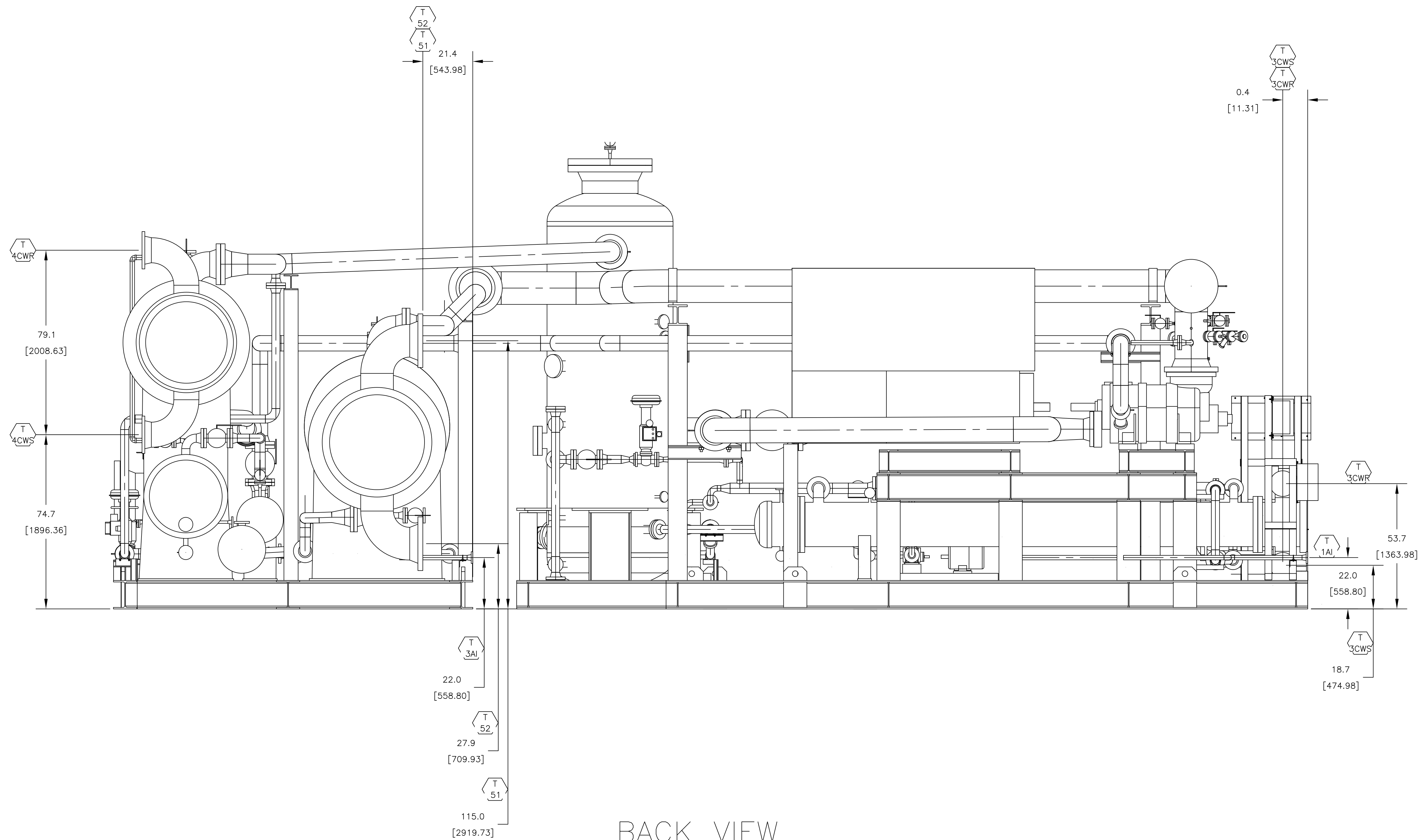

BACK VIEW

| | |
|---------|--|
| Code1 | <input type="checkbox"/> No Comment/ Approved (Applicable Only for "FOR REVIEW" and "For Approval" Documents) No comment and the document are released for Manufacturing |
| Code2 | <input type="checkbox"/> No Comment / Approved with Note(s) Vendor/Sub-Contractor shall correct, revise and resubmit the document. The document is released for Manufacturing if changes incorporated. |
| Code3 | <input type="checkbox"/> Commented Vendor/Sub-Contractor shall correct, revise and resubmit the document by the date specified. The document shall be revised under the Status of "R: Revised Issue". All corrected documents shall be resubmitted before starting the Manufacturing Process |
| Code4 | <input type="checkbox"/> Not Accepted (Rejected) Vendor/Sub-Contractor shall re-work/re-design/re-specify the contents of the document according to the comments/reasons for rejection. All corrected documents shall be resubmitted before starting the manufacturing. Vendor Sub-Contractor shall not proceed with subsequent work of Material Supply or Manufacturing until receiving Code1/Code2 or No Code from PURCHASER. Vendor/Sub-Contractor shall resubmit the document with the same revision within 6 working days after receiving comments |
| No Code | <input type="checkbox"/> No Code (Only for "For Information" Documents and "As Built DWGs") Document has been submitted for PURCHASER'S information (I). Consistency, completeness and correctness of document content is in Vendor/Sub-Contractor's responsibility. |

The above checking result by EIED shall in no way relieve Vendor of any liability, obligation and responsibility out of the purchase order and the mutual agreement in writing

EIED

DATE :
DEPT :
Signature :

| | | | | | |
|----|----|----|----|----|----|
| CV | PI | EL | IN | ME | MA |
| ST | BU | PR | SA | HV | TL |

| | | | | | |
|------|--------------------|---------------------|----------|---------|----------|
| 00 | 28-06-2025 | IFR | FA | IM | OG |
| REV. | DATE (DD.MM.YY) | Purpose of Issue | Prepared | Checked | Approved |

GPI
Gachsaran Polymer Industries Company

Gachsaran Polymer Industries Company
HDPE Plant

CONTRACT NO.: GPI-CON-99-008

PO No.: xxxxx

DRAWING TITLE:
General Arrangement Drawing (2D) (*Tie-In Points , Skid Dimensions & Orientation, Including Instrument, Junction Box and Local Panel Location Layout & Instrument Cable routing.) for Refrigerator Package



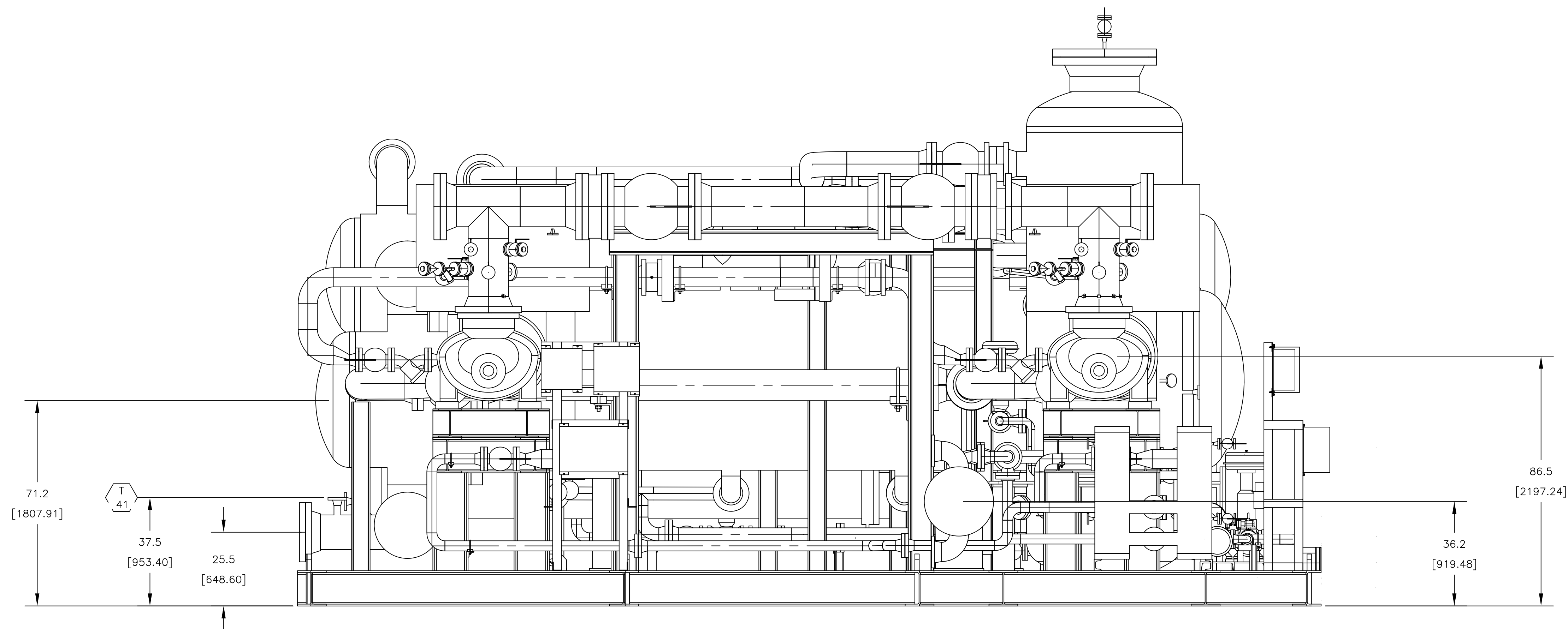

| | | | |
|-----------------------|------|-----------|------|
| DRAWING NO. | REV. | SHEET NO. | SIZE |
| VD-GPIC-MA-3029- 0062 | | 4 OF 9 | A1 |

SCALE: 1:1



LEFT VIEW

| | | | | | |
|---|--|----|----|----|----|
| Code1 | <input type="checkbox"/> No Comment/ Approved (Applicable Only for "FOR REVIEW" and "For Approval" Documents) No comment and the document are released for Manufacturing | | | | |
| Code2 | <input type="checkbox"/> No Comment / Approved with Note(s) Vendor/Sub-Contractor shall correct, revise and resubmit the document. The document is released for Manufacturing if changes incorporated. | | | | |
| Code3 | <input type="checkbox"/> Commented Vendor/Sub-Contractor shall correct, revise and resubmit the document by the date specified. The document shall be revised under the Status of "R: Revised Issue". All corrected documents shall be resubmitted before starting the Manufacturing Process | | | | |
| Code4 | <input type="checkbox"/> Not Accepted (Rejected) Vendor/Sub-Contractor shall re-work/re-design/re-specify the contents of the document according to the comments/reasons for rejection. All corrected documents shall be resubmitted before starting the manufacturing. Vendor Sub-Contractor shall not proceed with subsequent work of Material Supply or Manufacturing until receiving Code1/Code2 or No Code from PURCHASER. Vendor/Sub-Contractor shall resubmit the document with the same revision within 6 working days after receiving comments | | | | |
| No Code | <input type="checkbox"/> No Code (Only for "For Information" Documents and "As Built DWGs") Document has been submitted for PURCHASER'S information (I). Consistency, completeness and correctness of document content is in Vendor/Sub-Contractor's responsibility. The above checking result by EIED shall in no way relieve Vendor of any liability, obligation and responsibility out of the purchase order and the mutual agreement in writing | | | | |
|  DATE : DEPT : Signature : | | | | | |
| CV | PI | EL | IN | ME | MA |
| ST | BU | PR | SA | HV | TL |

| | | | | | |
|--|-----------------------|---|------------|---|----------|
| 00 | 28-06-2025 | IFR | FA | IM | OG |
| REV. | DATE (DD.MM.YY) | Purpose of Issue | Prepared | Checked | Approved |
|   | | Gachasan Polymer Industries Company HDPE Plant | |   | |
| CONTRACT NO.: GPI-CON-99-008 | | | SCALE: 1:1 | | |
| DRAWING TITLE: General Arrangement Drawing (2D) (*Tie-In Points , Skid Dimensions & Orientation, Including Instrument, Junction Box and Local Panel Location Layout & Instrument Cable routing.) for Refrigerator Package | | | | | |
| DRAWING NO. | VD-GPIC-MA-3029- 0062 | REV. | SHEET NO. | SIZE | |
| | | 5 | OF 9 | A1 | |

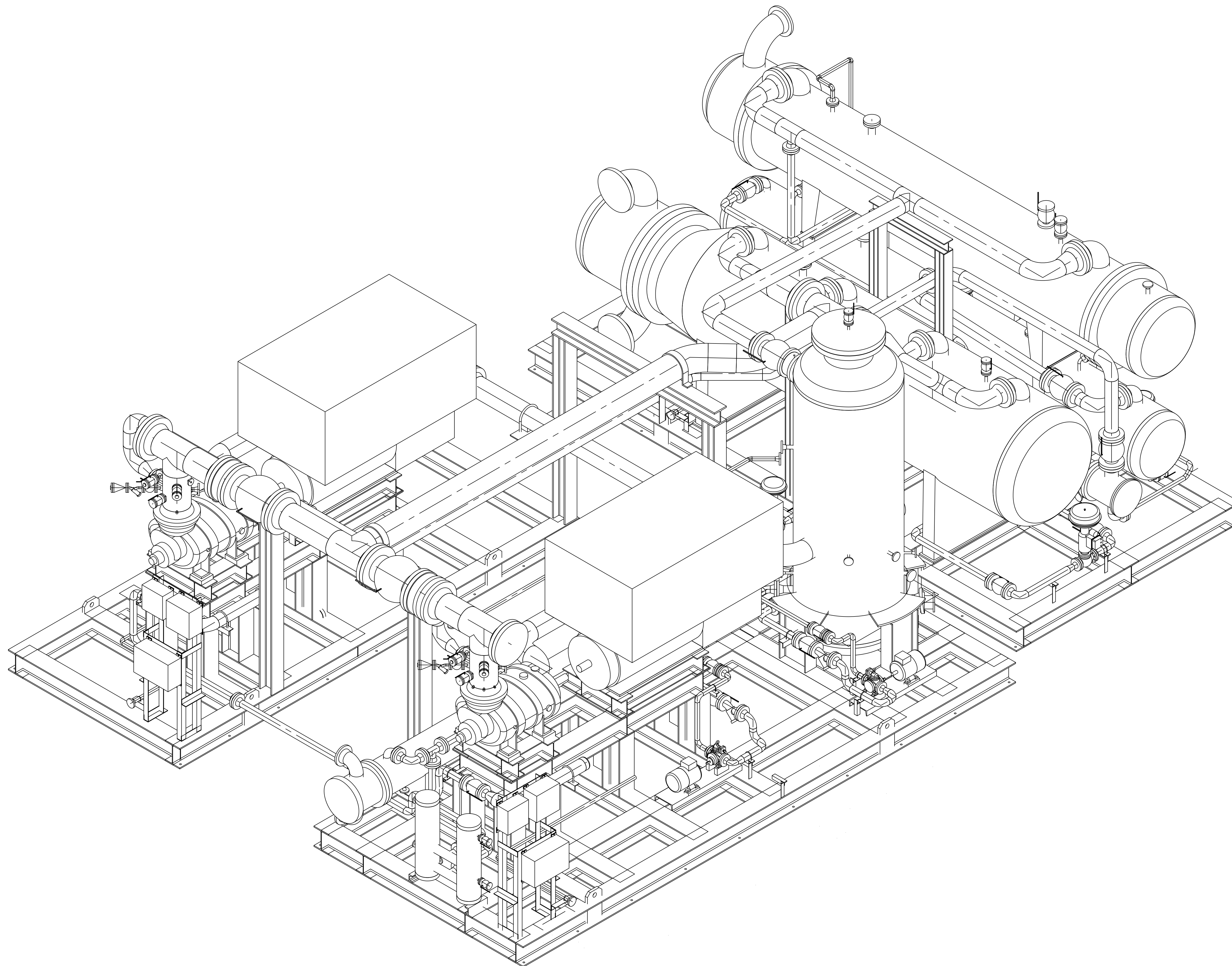





| | |
|---------|--|
| Code1 | <input type="checkbox"/> No Comment/ Approved (Applicable Only for "FOR REVIEW" and "For Approval" Documents) No comment and the document are released for Manufacturing |
| Code2 | <input type="checkbox"/> No Comment / Approved with Note(s) Vendor/Sub-Contractor shall correct, revise and resubmit the document. The document is released for Manufacturing if changes incorporated. |
| Code3 | <input type="checkbox"/> Commented Vendor/Sub-Contractor shall correct, revise and resubmit the document by the date specified. The document shall be revised under the Status of "R: Revised Issue". All corrected documents shall be resubmitted before starting the Manufacturing Process |
| Code4 | <input type="checkbox"/> Not Accepted (Rejected) Vendor/Sub-Contractor shall re-work/re-design/re-specify the contents of the document according to the comments/reasons for rejection. All corrected documents shall be resubmitted before starting the manufacturing. Vendor/Sub-Contractor shall not proceed with subsequent work of Material Supply or Manufacturing until receiving Code1/Code2 or No Code from PURCHASER. Vendor/Sub-Contractor shall resubmit the document with the same revision within 6 working days after receiving comments |
| No Code | <input type="checkbox"/> No Code (Only for "For Information" Documents and "As Built DWG") Document has been submitted for PURCHASER's information (I). Consistency, completeness and correctness of document content is in Vendor/Sub-Contractor's responsibility. |

The above checking result by EIED shall in no way relieve Vendor of any liability, obligation and responsibility out of the purchase order and the mutual agreement in writing

 DATE : _____
 DEPT: _____
 Signature : _____



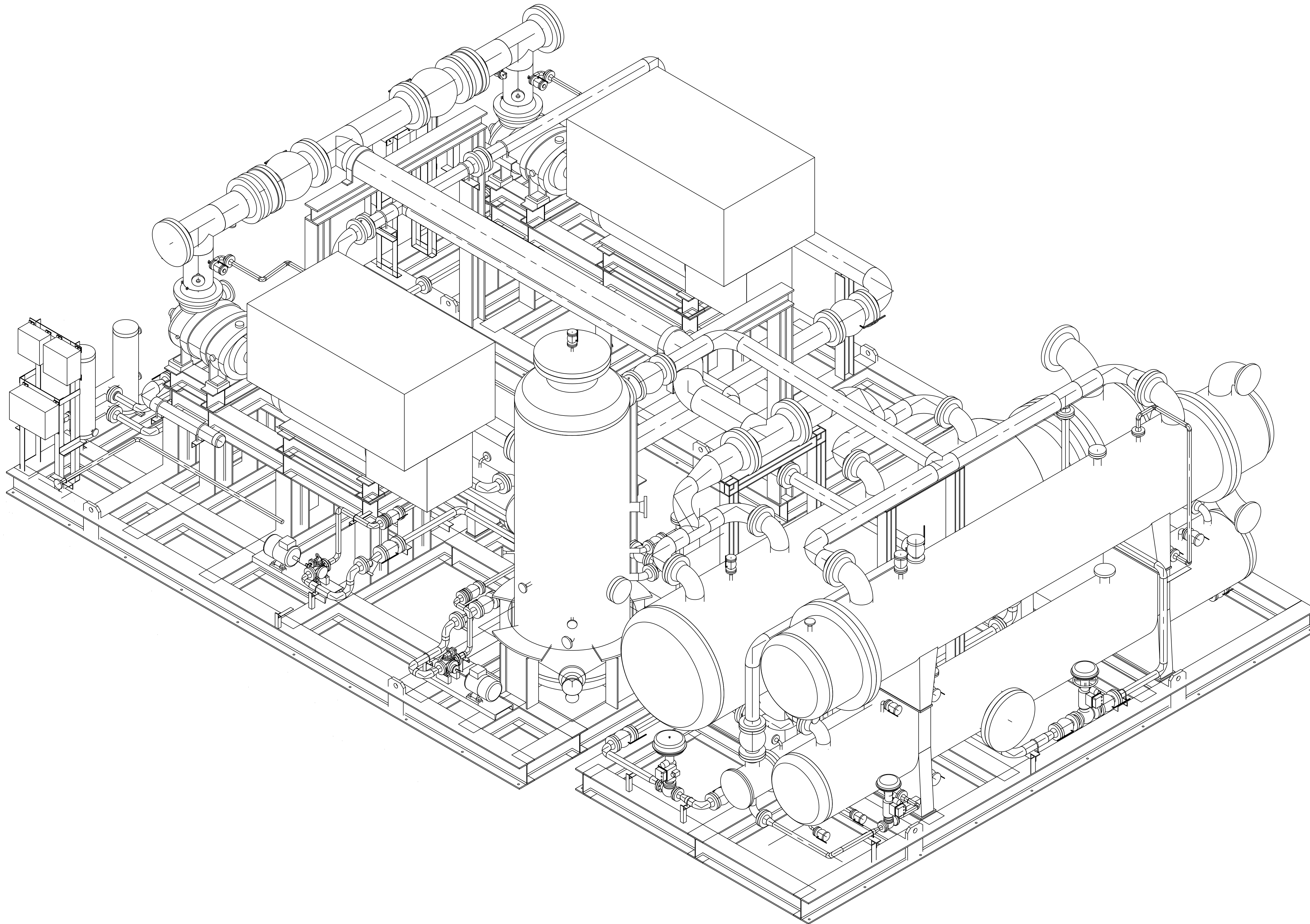

| | | | | | |
|----|----|----|----|----|----|
| CV | PI | EL | IN | ME | MA |
| ST | BU | PR | SA | HV | TL |

| | | | | | |
|--|--------------------|---|------------|---|----------|
| 00 | 28-06-2025 | IFR | FA | IM | OG |
| REV. | DATE (dd.MM.Yy) | Purpose of Issue | Prepared | Checked | Approved |
|   | | Gachasan Polymer Industries Company HDPE Plant | |   | |
| CONTRACT NO.: GPI-CON-99-008 | | | SCALE: 1:1 | | |
| DRAWING TITLE: General Arrangement Drawing (2D) (*Tie-In Points , Skid Dimensions & Orientation, Including Instrument, Junction Box and Local Panel Location Layout & Instrument Cable routing.) for Refrigerator Package | | | | | |
| DRAWING NO. | | REV. | | SHEET NO. | |
| VD-GPIC-MA-3029- 0062 | | 6 OF 9 | | A1 | |



| | | | | | |
|--|---|----|----|----|----|
| Code1 | <input type="checkbox"/> No Comment/ Approved (Applicable Only for "FOR REVIEW" and "For Approval" Documents) No comment and the document are released for Manufacturing | | | | |
| Code2 | <input type="checkbox"/> No Comment / Approved with Note(s) Vendor/Sub-Contractor shall correct, revise and resubmit the document. The document is released for Manufacturing if changes incorporated. | | | | |
| Code3 | <input type="checkbox"/> Commented Vendor/Sub-Contractor shall correct, revise and resubmit the document by the date specified. The document shall be revised under the Status of "R: Revised Issue". All corrected documents shall be resubmitted before starting the Manufacturing Process | | | | |
| Code4 | <input type="checkbox"/> Not Accepted (Rejected) Vendor/Sub-Contractor shall re-work/re-design/re-specify the contents of the document according to the comments/reasons for rejection. All corrected documents shall be resubmitted before starting the manufacturing. Vendor Sub-Contractor shall not proceed with subsequent works of Material Supply or Manufacturing until receiving Code1/Code2 or No Code from PURCHASER. Vendor/Sub-Contractor shall resubmit the document with the same revision within 6 working days after receiving comments | | | | |
| No Code | <input type="checkbox"/> No Code (Only for "For Information" Documents and "As Built DWGs") Document has been submitted for PURCHASER'S Information (I). Consistency, completeness and correctness of document content is in Vendor/Sub-Contractor's responsibility. | | | | |
| The above checking result by EIED shall in no way relieve Vendor of any liability, obligation and responsibility out of the purchase order and the mutual agreement in writing | | | | | |
|  DATE : _____ DEPT: _____ Signature : _____ | | | | | |
| CV | PI | EL | IN | ME | MA |
| ST | BU | FR | SA | HV | TL |

| | | | | | |
|------|--------------------|---------------------|----------|---------|----------|
| 00 | 28-06-2025 | IFR | FA | IM | OG |
| REV. | DATE (DD.MM.YY) | Purpose of Issue | Prepared | Checked | Approved |

| | | | |
|---|---|---|---|
|  |  | Gachasan Plymer Industries Company |  |
| | | HDPE Plant |  |
| CONTRACT NO.: GPI-CON-99-008 | | | SCALE: 1:1 |

PO No.: xxxxx

DRAWING TITLE:
General Arrangement Drawing (2D) (*Tie-In Points , Skid Dimensions & Orientation, Including Instrument, Junction Box and Local Panel Location Layout & Instrument Cable routing.) for Refrigerator Package

| | | | | |
|-------------|-----------------------|------|-----------|------|
| DRAWING NO. | VD-GPIC-MA-3029- 0062 | REV. | SHEET NO. | SIZE |
| | | | 7 OF 9 | A1 |

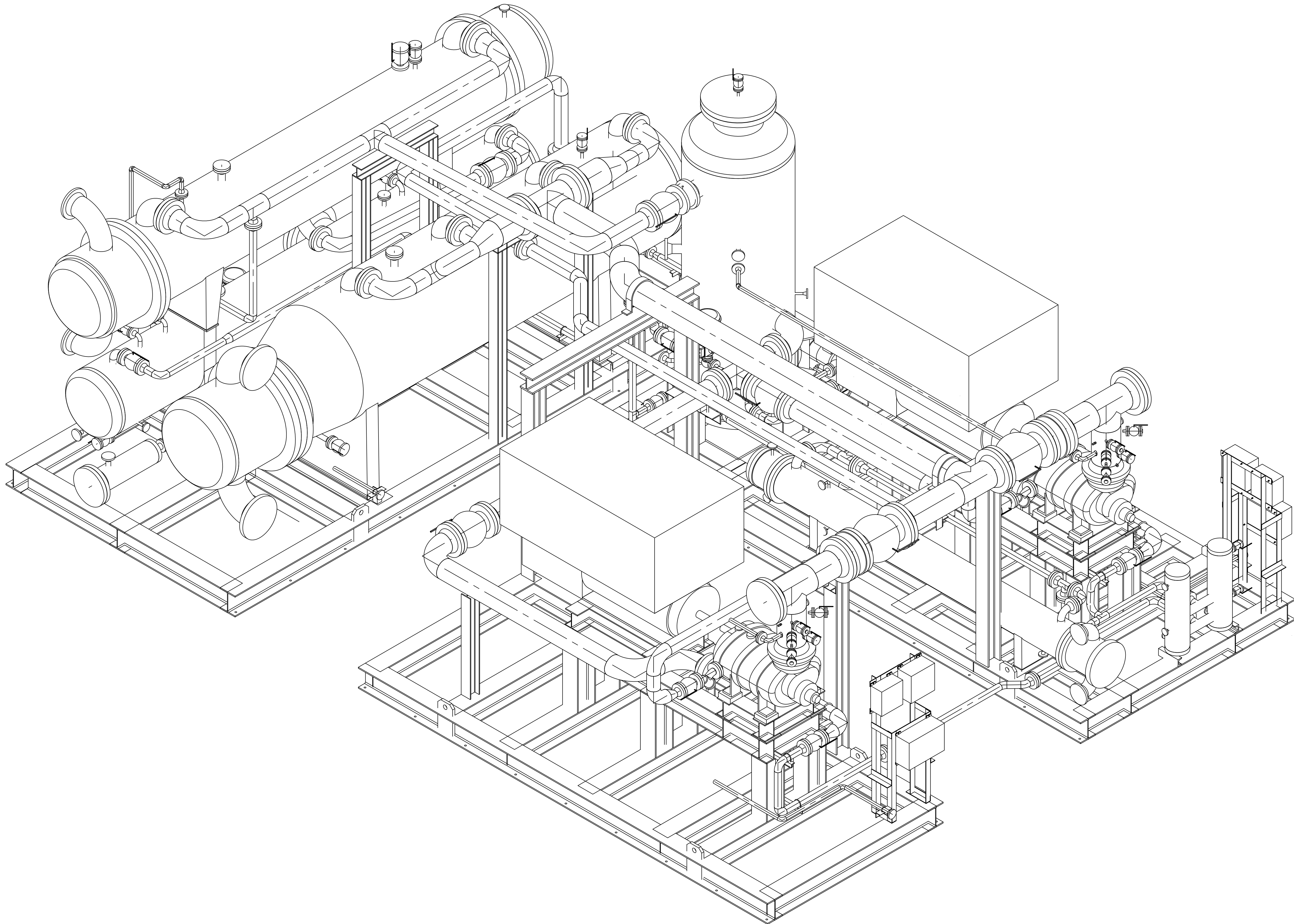

Code1 No Comment/ Approved
(Applicable Only for "FOR REVIEW" and "For Approval" Documents) No comment and the document are released for Manufacturing

Code2 No Comment / Approved with Note(s)
Vendor/Sub-Contractor shall correct, revise and resubmit the document. The document is released for Manufacturing if changes incorporated.

Code3 Commented
Vendor/Sub-Contractor shall correct, revise and resubmit the document by the date specified. The document shall be revised under the Status of "R: Revised Issue". All corrected documents shall be resubmitted before starting the Manufacturing Process



Code4 Not Accepted (Rejected)
Vendor/Sub-Contractor shall re-work/re-design/re-specify the contents of the document according to the comments/reasons for rejection. All corrected documents shall be resubmitted before starting the manufacturing. Vendor Sub-Contractor shall not proceed with subsequent works of Material Supply or Manufacturing until receiving Code1/Code2 or No Code from PURCHASER. Vendor/Sub-Contractor shall resubmit the document with the same revision within 6 working days after receiving comments



No Code No Code
(Only for "For Information" Documents and "As Built DWGs") Document has been submitted for PURCHASER'S information (I). Consistency, completeness and correctness of document content is in Vendor/Sub-Contractor's responsibility.

The above checking result by EIED shall in no way relieve Vendor of any liability, obligation and responsibility out of the purchase order and the mutual agreement in writing

DATE :
DEPT :
Signature :
CV PI EL IN ME MA
ST BU PR SA HV TL

| | | | | | |
|------|---------------------|---------------------|----------|---------|----------|
| 00 | 28-06-2025 | IFR | FA | IM | OG |
| REV. | DATE (DD.MMM.YY) | Purpose of Issue | Prepared | Checked | Approved |



Gachasan Plymter Industries Company
HDPE Plant
 CONTRACT NO.: GPI-CON-99-008

PO No.: xxxxx SCALE: 1:1

DRAWING TITLE:
General Arrangement Drawing (2D) (*Tie-In Points , Skid Dimensions & Orientation, Including Instrument, Junction Box and Local Panel Location Layout & Instrument Cable routing.) for Refrigerator Package

| | | | | |
|-------------|-----------------------|------|-----------|------|
| DRAWING NO. | VD-GPIC-MA-3029- 0062 | REV. | SHEET NO. | SIZE |
| | | | 8 OF 9 | A1 |

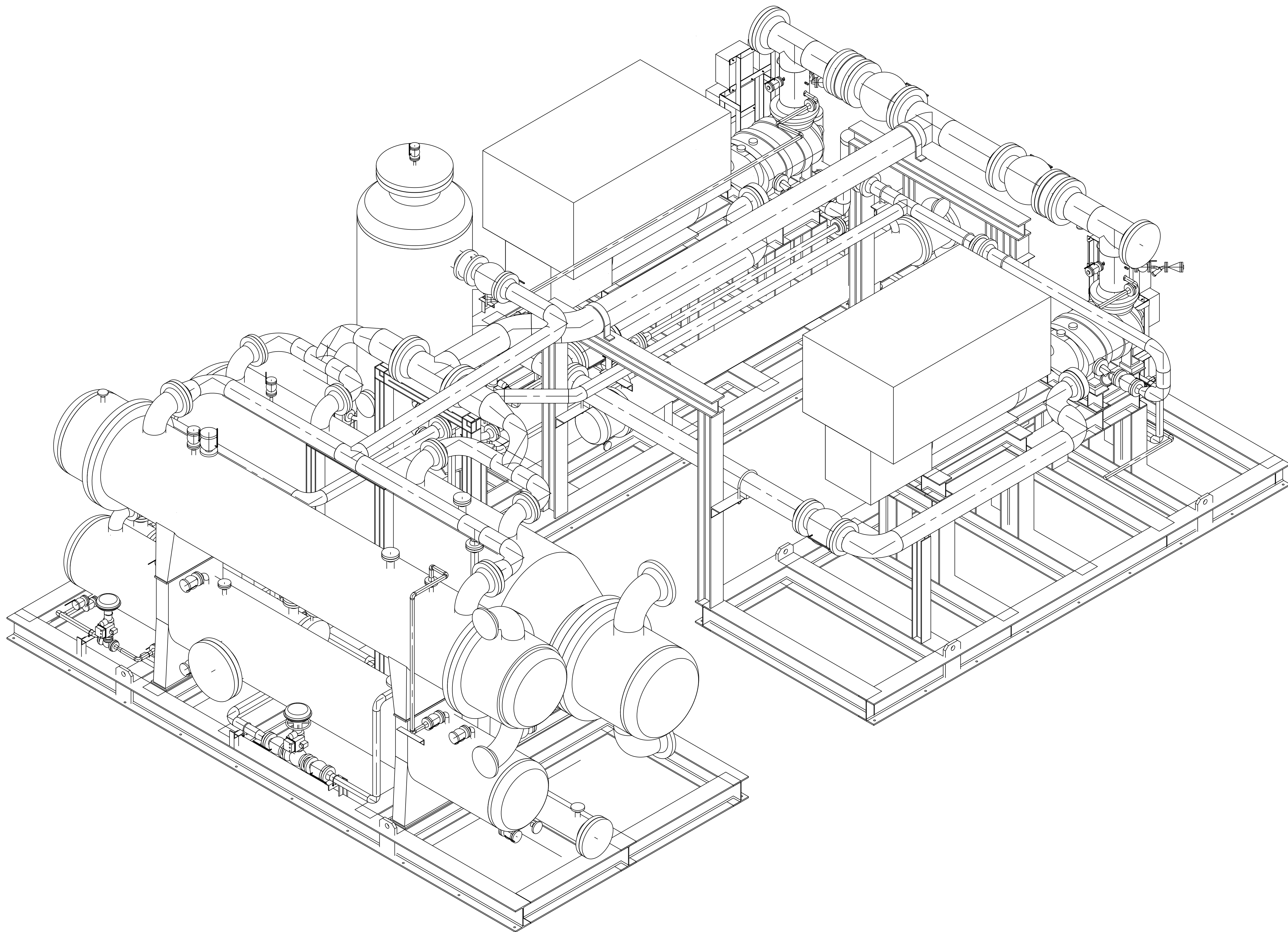





| | |
|---------|---|
| Code1 | <input type="checkbox"/> No Comment/ Approved (Applicable Only for "FOR REVIEW" and "For Approval" Documents) No comment and the document are released for Manufacturing |
| Code2 | <input type="checkbox"/> No Comment / Approved with Note(s) Vendor/Sub-Contractor shall correct, revise and resubmit the document. The document is released for Manufacturing if changes incorporated. |
| Code3 | <input type="checkbox"/> Commented Vendor/Sub-Contractor shall correct, revise and resubmit the document by the date specified. The document shall be revised under the Status of "R: Revised Issue". All corrected documents shall be resubmitted before starting the Manufacturing Process |
| Code4 | <input type="checkbox"/> Not Accepted (Rejected) Vendor/Sub-Contractor shall re-work/re-design/re-specify the contents of the document according to the comments/reasons for rejection. All corrected documents shall be resubmitted before starting the manufacturing. Vendor Sub-Contractor shall not proceed with subsequent works of Material Supply or Manufacturing until receiving Code1/Code2 or No Code from PURCHASER. Vendor/Sub-Contractor shall resubmit the document with the same revision within 6 working days after receiving comments |
| No Code | <input type="checkbox"/> No Code (Only for "For Information" Documents and "As Built DWGs") Document has been submitted for PURCHASER's information (I). Consistency, completeness and correctness of document content is in Vendor/Sub-Contractor's responsibility. |

The above checking result by EIED shall in no way relieve Vendor of any liability, obligation and responsibility out of the purchase order and the mutual agreement in writing

 DATE : _____
 DEPT: _____
 Signature : _____

| | | | | | |
|----|----|----|----|----|----|
| CV | PI | EL | IN | ME | MA |
| ST | BU | FR | SA | HV | TL |

| | | | | | |
|---|-----------------------|---|-----------|--|----------|
| 00 | 28-06-2025 | IFR | FA | IM | OG |
| REV. | DATE (DD.MM.YY) | Purpose of Issue | Prepared | Checked | Approved |
|   | | Gachasan Polymer Industries Company HDPE Plant | |   | |
| CONTRACT NO.: GPI-CON-99-008 | | SCALE: 1:1 | | | |
| PO No.: xxxxx DRAWING TITLE: General Arrangement Drawing (2D) (*Tie-In Points , Skid Dimensions & Orientation, Including Instrument, Junction Box and Local Panel Location Layout & Instrument Cable routing.) for Refrigerator Package | | | | | |
| DRAWING NO. | VD-GPIC-MA-3029- 0062 | REV. | SHEET NO. | SIZE | |
| | | 9 | OF 9 | A1 | |