



MAYEKAWA Doc No.:

MPE005 - 00135

NO.	BY	APP	DATE	DESCRIPTION
0	DGJ	IES	23 Feb 2023	FOR INFORMATION

COMPRESSOR TESTING PROCEDURE

FOR	Gachsaran Polymer Industries Company (GPIC)	MFR	MAYEKAWA
JOB No.	-	ITEM No.	PK-6101
P. O. No.	GPIC-PT-MA-PO-000-3029		
SITE	-		
SERVICE	PROPYELENE REFRIGERATION PACKAGE		

ITEM	PROCEDURE	DESCRIPTION	APPLICABLE
0	SCSD-000-00	Material Equivalency	Y
1	SCSD-001-01	General Rules for Witness Inspection	
2	SCSD-002-04	Material Test for Rotors	Y
3	SCSD-003-04	Nondestructive Examination(MT, UT, and PT) for Rotors	Y
4	SCSD-004-04	Material Test for Casing	Y
5	SCSD-005-04	NDE for Casing Magnetic Particle Test	
6	SCSD-006-03	NDE for Casing Penetrant Test	Y
7	SCSD-007-08	Screw Rotor Dynamic Balance Test	Y
8	SCSD-008-02	Hydrostatic Test	Y
9	SCSD-009-02	Gas Leak Test (Pneumatic Test)	Y
10	SCSD-010-10	Performance Test, Mechanical Running, Noise Test, and Vibration Test	Y
11	SCSD-011-		
12	SCSD-012-		
13	SCSD-013-		
14	SCSD-014-		
15	SCSD-015-01	Dismantling Inspection	
16	SCSD-016-02	Appearance and Dimensional Test (Shipment Check)	Y
17	SCSD-017-05	Painting Check	Y
18	SCSD-018-01	Shipment Check	Y
19	SCSD-019-		
20	SCSD-020-		
21	SCSD-021-		
22	SCSD-022-03	End Clearance Run Out Inspection	
23	SCSD-023-02	PMI Inspection_ Casing Bolt	
24	SCSD-024-01	PMI Inspection_ Rotor	

List of Equivalent Code List for Mycom Screw Compressor

	MATERIAL NAME	JIS CODE	ASTM CODE
Blind Cover Casing Unloader Cylinder Unloader Cylinder Cover Rotor Casing Suction Cover Casing Bearing Head Casing Bearing Cover Casing Seal Cover Casing	Low temp. Cast Steel	G5152, SCPL1	A352, LCB
Rotor	Forged Steel	G3221, SFCM930S	A290, A291, A668 class M (668-M-95a)
Hanger Bolt	Carbon Steel	G4051, S17C	ANSI 1017
Plug	Carbon Steel	G4501, S45C-H, 25C	AISI 1045, 1025
Unloader Slide Valve I Unloader Piston Seal Gland Balance Piston Sleeve Thrust Bearing Gland	Cast Iron	G5501, FC300	A48, Class No.45
Guide Block Threaded Guide Block Stem Shaft Key Oil Injection Pipe Gland Parallel Pin Alignment Pin Bearing Spacer Washer O-ring Gland Thrust Washer Balance Piston Key Indicator Cam	Carbon Steel	G4051, S45C	AISI 1045
Balance Piston	Carbon Steel	G4051, S35C	AISI 1035
Spring Retainer	Carbon Steel	G4051, S25C	AISI 1025
Hexagonal Socket Head Cap Screw Gland Bolt	Chromium Molybdenum Steel	G4105, SCM435	AISI 4135 to 4137
Spring Pin	Carbon Tool Steel	S60CM	AISI 1060
Torsional Slip Washer	Carbon Tool Steel	G4401, SK5	
Unloader Slide Valve II	Nodular Cast Iron	G5502, FCD450	A536
Indicator Cam Oil Injection Pipe	Carbon Steel	G3445, STKM16C	A513, MT1026
Unloader Slide Valve Guide Oil Seal Retainer	Cast Iron	G5501, FC250	A48, No. 40
Snap Ring Special Spring Washer Spring Washer Stop Ring	High Carbon Steel Wire Rods	G3506, SWRH	A510
Guide Pin	Low Carbon Steel Wire Rods	G3505, SWRM	A510
Spring	Piano Wire	G3522, SWPB	A228
Bearing Gland Spacer Lock Nut	Cast Steel	G3101, SS400	A 36 - 89b
Unloader Push Rod	Carbon Steel	G3101, SS400B-D	A 36 - 89b
Lock Washer	Carbon Steel	G3141, SPCC	A366
Ball Bearing for Indicator	Carbon Chromium Steel	G4805, SUJ2	A295, 52100
Main / Side Bearing (Cage)	Carbon steel	G3445, STKM13A	A513, MT1020
Main / Side Bearing (Babbitt)	White Metal	H5401, WJ-2/WJ-10	B23 - 73
Ball Thrust Bearing (Cage)	High Carbon Steel	G4805, SUJ-2	A295, 52100
Ball Thrust Bearing (Ball)	Carbon Chromium Steel	G4805, SUJ-2	A295, 52100
Stop Ring for Bearing	Carbon Steel	G4801, SUP3	A689, A576, ASTM 1078
Guide Pin	Alloy Steel	SAE8630	AISI 8630

Material Test for Rotors

Rotor material	<input type="checkbox"/> FCD600	<input type="checkbox"/> SFCM930S	<input type="checkbox"/> SFCM740S
----------------	---------------------------------	-----------------------------------	-----------------------------------

1. Scope

This procedure defines material tests of the male rotor and the female rotor.

2. Test Method

In accordance with JIS standards each test should be carried out at the rotor manufacturer. A visual check is made of the finished pieces and confirm the submitted material test reports.

3. Acceptance Criteria**3.1 JIS G 5502 : FCD600 (Equivalent to ASTM A 536)**

Part name: male rotor, female rotor (including shaft)

3.1.1 Chemical Composition

Chemical composition (%) FCD600					
C	Si	Mn	P	S	Mg
2.5 and more	-	-	-	0.02 or less	0.09 or less

3.1.2 Mechanical properties

A. Tensile test (JIS Z 2241) :

Tensile strength (N/mm²) 600min

0.2%Yield strength (N/mm²) 370min

Elongation (%) 3min

B. Hardness test (JIS Z 2243) :

Hardness (HB)170 to 270

3.2 JIS G 3221 : SFCM930S (equivalent to ASTM A 668)

Part name: male rotor, female rotor (including shaft)

3.2.1 Chemical Composition (JIS G3221)

Chemical composition (%) SFCM930S						
C	Si	Mn	P	S	Cr	Mo
0.48 max	0.15-0.35	0.30-0.85	0.030 max	0.030 max	0.90-1.50	0.15-0.30

3.2.2 Heat Treatment

Based on the rotor manufacturer's experience, the heat treatment should comply with the mechanical properties described in 3.2.3.

3.2.3 Mechanical Properties

- A. Tensile test (JIS Z2241):
- | | |
|---------------------------------------|-------------|
| Yield point (N/mm ²) | 705min |
| Tensile strength (N/mm ²) | 930 to 1080 |
| Elongation (%) | 12min |
| Reduction of area (%) | 37min |
- B. Impact test (JIS 2242):
- | | |
|------------------|-------|
| Impact value (J) | 44min |
|------------------|-------|
- C. Hardness test (JIS Z2243):
- | | |
|---------------|--------|
| Hardness (HB) | 269min |
|---------------|--------|

3.3 JIS G 3221: SFCM740S (equivalent to ASTM 668K)

Part name: male rotor, female rotor (including shaft)

3.3.1 Chemical Composition(JIS G3221)

Chemical composition (%) SFCM740S						
C	Si	Mn	P	S	Cr	Mo
0.48 max	0.15 [—] 0.35	0.30 [—] 0.85	0.030 max	0.030 max	0.90 [—] 1.50	0.15 [—] 0.30

3.3.2 Heat Treatment

Based on the rotor manufacturer's experience, the heat treatment must comply with the mechanical properties described in 3.3.3.

3.3.3 Mechanical Properties

- A. Tensile test (JIS Z2241):
- | | |
|---------------------------------------|------------|
| Yield point (N/mm ²) | 510min |
| Tensile strength (N/mm ²) | 740 to 880 |
| Elongation (%) | 16min |
| Reduction of area (%) | 45min |
- B. Impact test (JIS 2242):
- | | |
|------------------|-------|
| Impact value (J) | 64min |
|------------------|-------|
- C. Hardness test (JIS Z2243):
- | | |
|---------------|--------|
| Hardness (HB) | 217min |
|---------------|--------|

4. Records

The test results are recorded on the submitted documents such as Certificate of materials and Result of material test from the rotor manufacturer.

According to the rotor manufacturer's criteria, markings (the name of manufacturer and the date) are applied.

Screw Compressors Standard Inspection Procedures
Document No. SCSD-003-04
Nondestructive Examination(MT, UT, and PT) for Rotors

Moriya Plant, Mayekawa Mfg. Co., Ltd.

04	2019/02/05	Konno	Koizumi	Kato	Review and revised
03	2016/05/17	Suzukawa	Sasaki	Kawasaki	Review and revised
02	2016/04/01	Suzukawa	Sasaki	Kawasaki	Review and revised
01	2011/07/01	Sasaki	Ikehara	Shozu	Review and revised
00	06/05/06	Ikehara	Amada	Koizumi	Newly created
Revision	Date	Created by	confirmed by	Approved by	Description

Nondestructive Examination for Rotors

rotor material	<input type="checkbox"/> SFCM930S	<input type="checkbox"/> SFCM740S	<input type="checkbox"/> FCD600
NDE	<input type="checkbox"/> MT	<input type="checkbox"/> PT	<input type="checkbox"/> UT

1. Scope

This procedure defines nondestructive examinations (MT: magnetic particle examination, UT: ultrasonic examination, and PT: liquid penetrant examination) of the male rotor and the female rotor to be used for MYCOM screw compressors.

2. Examination Methods

2.1 Magnetic Examination for Rotors

In accordance with JIS Z 2320-1:2007 "Non-destructive testing -- Magnetic particle testing -- Part 1: General principles", magnetic examination is performed. Testing locations are shown in Figure 1. A visual check is made of the submitted results of the magnetic examination and the finished pieces.

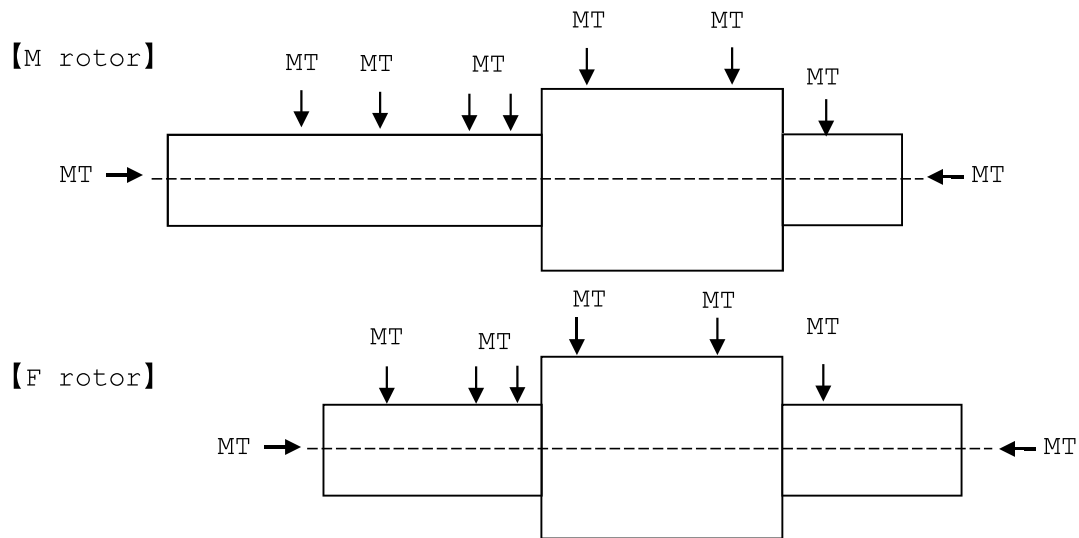

Figure 1. Magnetic examination locations

2.2 Ultrasonic Examination of Rotors

- UT for raw material surface □ UT for finished surface

In accordance with JIS Z 2344:1993 "General rule of ultrasonic testing of metals by pulse echo technique", ultrasonic examination is performed. Testing locations are shown in Figure 2.

a) UT for raw material surface

b) UT for finished surface

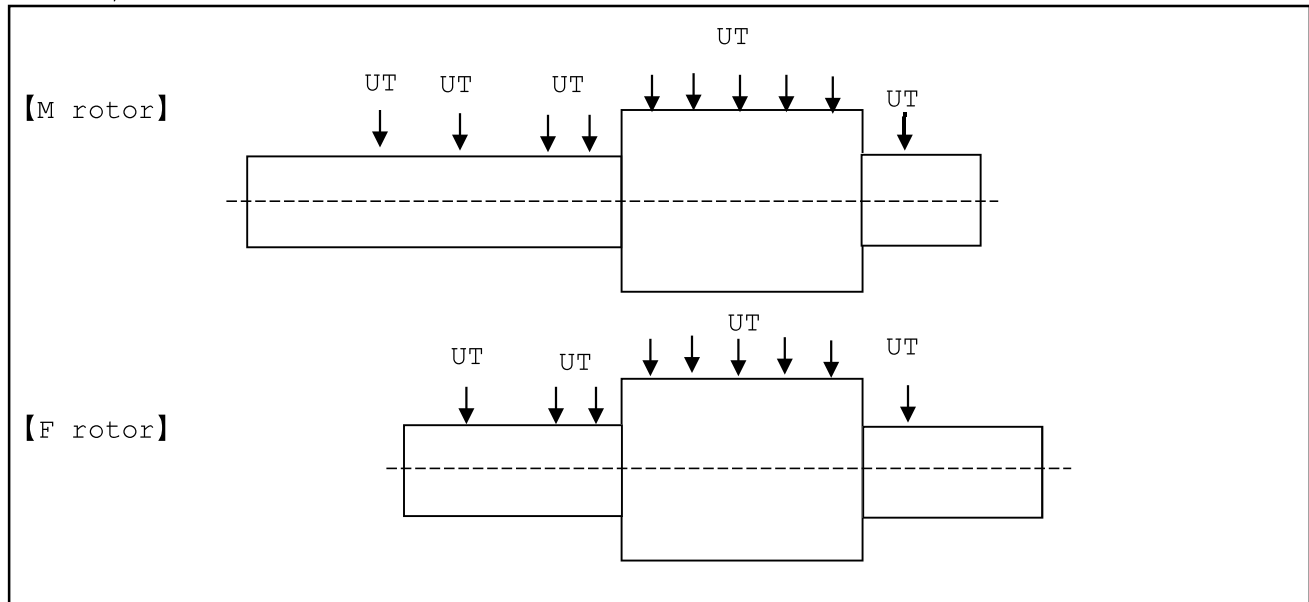

a) raw material surface

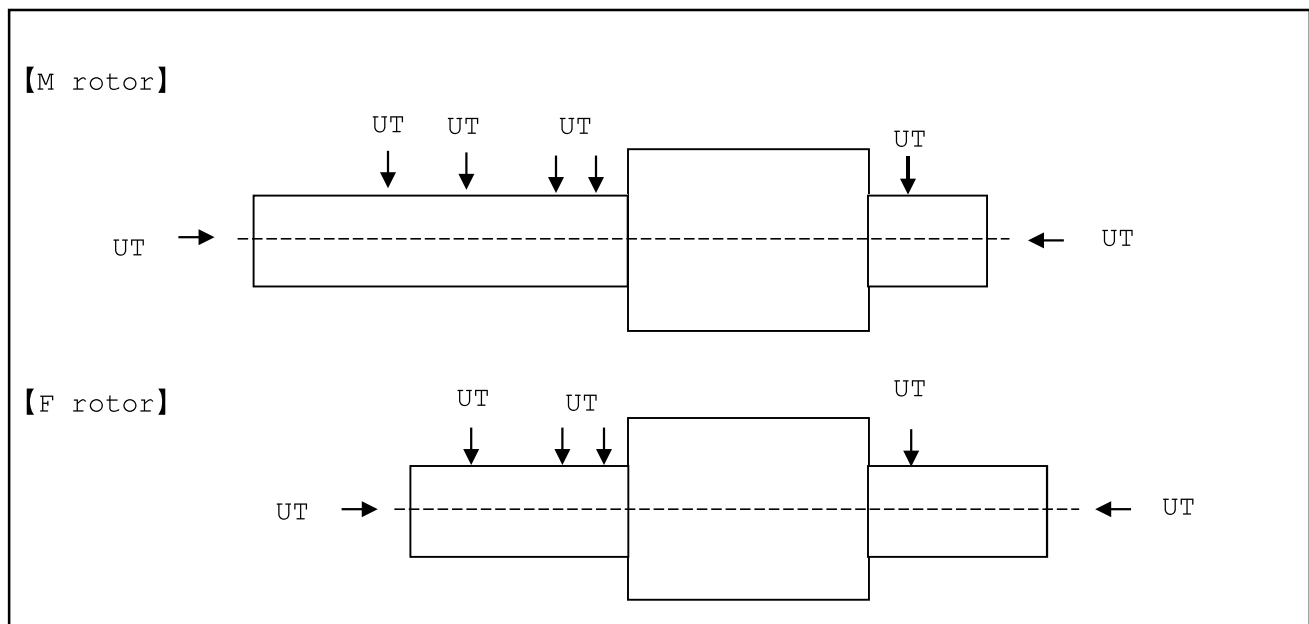

b) finished material surface

Figure 2. Ultrasonic examination locations

2.3 Penetrant Examination

In accordance with JIS Z 2343-1:2001 "Non-destructive testing -- Penetrant testing -- Part 1: General principles -- Method for liquid penetrant testing and classification of the penetrant indication", liquid penetrant examination is performed. Testing locations are shown in Figure 3. A visual check is made of the submitted results of the magnetic examination and the finished pieces.

【M rotor】

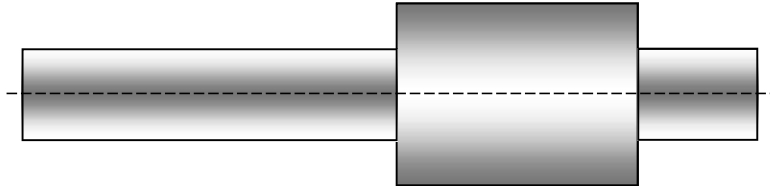

【F rotor】

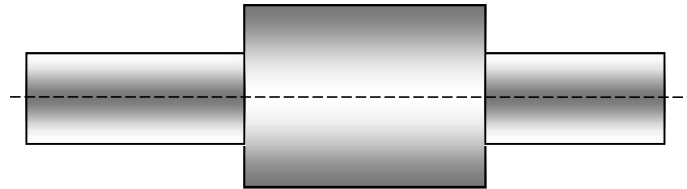

Figure 3. Liquid penetrant examination locations

3. Acceptance Criteria

3.1 Magnetic Examination

Stipulated in JIS Z2320-1:2007 and The High Pressure Gas Safety Act, Designated Equipment Inspection Regulations.

Types of defects	Criteria	Remarks
1. Cracks indicating magnetic particles	There is no magnetic particle indication of cracks	-Linear magnetic particle indication: Length exceeds 3 times the width.
2. Independent magnetic particle indicators 1) Linear magnetic particle indication 2) Circular magnetic particle indicators	4mm or less 4mm or less	-Circular magnetic particle indication: Any magnetic particle indication other than linear magnetic particle indication. -Continuous magnetic particle indication: More than one magnetic particle indicator near the same line and the distance
3. Continuous magnetic particle indicators	Must be 12 or less flaws within	

4. Dispersed magnetic particle indicators.	2,500mm ² The flaws are calculated as the sum of the products of the number of defects on the following table and the corresponding factors shown.	of each is 2mm or less. -Dispersed magnetic particle indication: Multiple magnetic indicators spread in a constant area.
--	---	--

Factors

Defect indication	Max. Length/diameter 2mm or less	Max. Length/diameter 4mm or less
Linear magnetic indicator	3	6
Circular magnetic indicator	1	2

3.2 Ultrasonic Examination

In accordance with JIS G0587 "Ultrasonic examination for carbon steel and low alloy steel forgings(classification 1)"

Types of defects	Criteria	Remarks
Equivalent defect diameter(d)	$d \leq 4\text{mm}$	Test based on bottom surface echo.

3.3 Liquid Penetrant Examination

The criteria of the magnetic examination is applied to the criteria of the liquid penetrant examination where magnetic indication is equivalent to liquid penetrant indication.

4. Records

The results are recorded in the relevant documentation by the rotor manufacturer. The name of the manufacturer and the date are marked on the piece in accordance with the manufacturer's requirements.

Record Sample (MT)

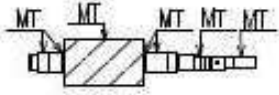
JOB No. :	磁粉探傷検査報告書		試験-検査記録	
TAG No. :	MAGNETIC PARTICLES		INSPECTION AND RECORDS	
製造番号 SERIAL No.	LOCATION		日付 DATE	
注文主 CLIENT	MAYUKAWA MFG.CO.,LTD.			
工事名称 JOB NAME	Screw Compressor			
検査場所 PLACE	MAYUKAWA MFG.CO.,LTD. MORIYA FACTORY			
部品名称 / (チャージ No.) PARTS NAME / (Charge No.)	MALE ROTOR ()		FEMALE ROTOR ()	
検査箇所 TEST SECTION	ALL EXTERNAL SURFACE			
材質 MATERIAL	JIS G 3221 SFCM930S			
合格基準 ACCEPTANCE STANDARD	JIS Z 2320-1		Criterion	
	Type of defects		: There is no magnetic particle indication by cracks.	
	Magnetic particle indication by cracks		: 4mm or less	
	Liner defects magnetic particle indication		: 4mm or less	
	Circular defects magnetic particle indication		: The flaw mark to be 12 or less within 2500mm ²	
	Distributed defects magnetic particle indication			
検査装置 TEST EQUIPMENT	NIHON DENJI SOKKI NC-2Y			
探傷灯 BLACK LIGHT	MARKTEC D-10			
検査条件 TEST CONDITION				
検査方法 METHOD OF MAGNETIZATION	YOKE MAGNETIZATION : AC			
磁粉適用方法 APPLICATION OF MAGNETIC PARTICLES	"WET" CONTINUOUS MAGNETIZATION TECHNIQUE			
リフティングパワー LIFTING POWER	約4.5kg以上 AT LEAST 10lbs	通電時間 TIME OF PASSING CURREN	5秒以上 5 SEC OVER	
磁粉の種類 MAGNETIC PARTICLES	FLUORESCENT PARTICLES / EISHIN SY-8000 TYPE			
検査液 TEST LIQUID	MEDIUM OF DISPERSION	KEROSENE	DENSITY 0.8 g / lit	
標準 STANDARD REFERENCE BLOCK	JIS A1-15 / 100			
検査員 N.D.E.PERSONNEL	/ NDI-CLASS II			
判定 EVALUATION	ACCEPTED			
				
			Figure	

日本非破壊検査株式会社 NIHON NONDESTRUCTION INSPECTION CO., LTD.

Record Sample (UT)

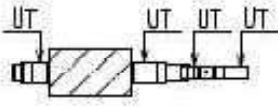
JOB No. : TAG No. :	超音波探傷検査報告書 ULTRASONIC EXAMINATION	試験・検査記録 INSPECTION AND RECORDS
製造番号 SERIAL No. 2553331	PORT	日付 DATE December 20, 2017
注文主 CLIENT	MAEKAWA MFG CO., LTD.	
工事名称 JOB NAME	Screw Compressor Model: AHS3U14	
検査場所 PLACE	MAEKAWA MFG CO., LTD. MORIYA FACTORY	
部品名称 / (チャージ No.) PARTS NAME / (Charge No.)	MALE ROTOR (S1-93280-4) FEMALE ROTOR (S1-98225-1)	
材質 MATERIAL	JIS G 3221 SFCM930S	
合格基準 ACCEPTANCE STANDARD	JIS G 0587 Type of defects Criterion Equivalent defect diameter (d) : d < 4mm	
検査装置 TEST EQUIPMENT	PANAMETRICS-NDT EPOCH XT PANAMETRICS-NDT EPOCH 4	
検査条件 TEST CONDITION		
検査方法 METHOD	NOMAL INCIDENCE SINGLE PROBE TECH	
探触子 CONTACTING ELEMENT	Japan Probe 5Z10N / Japan Probe 2C10N	
探傷周波数 FREQUENCY	2MHz / 5 MHz	
探触媒質 TEST LIQUID	MACHINE OIL	
探傷感度 SENSITIVITY	BACK ECHO 100% AT SOUND AREA	
標準試験片 STANDARD REFERENCE BLOCK	BACK ECHO METHOD	
検査箇所 SECTION EXAMINED		
検査員 N.D.E PERSONNEL	/ NDI-CLASS II	
判定 EVALUATION	ACCEPTED	

日本非破壊検査株式会社 NIHON NONDESTRUCTION INSPECTION CO., LTD.

Record Sample (PT)

JOB No. :	浸透探傷検査報告書 LIQUID PENETRANT INSPECTION	試験-検査記録 INSPECTION AND RECORDS
TAG No. :		日付 DATE December 20, 2013
製造番号 SERIAL No. 2553331		
注文主 CLIENT		
工事名称 JOB NAME	Screw Compressor Model AP10821F	
検査場所 PLACE	MORITA MFG. CO., LTD. MORIYA FACTORY	
部品名称 / (チャージ No.) PARTS NAME (Charge No.)	MALE ROTOR (S1-93280-4) FEMALE ROTOR (S1-98225-1)	
検査箇所 TEST SECTION	ALL EXTERNAL SURFACE	
材質 MATERIAL	JIS G 3221 SFCM930S	
合格基準 ACCEPTANCE STANDARD	JIS Z 2343-1 Type of defects Indication by cracks Liner defects indication Circular defects indication Distributed defects indication	Criterion : There is no indication by cracks. : 4mm or less : 4mm or less : The flaw mark to be 12 or less within 2500mm ²
表面状態 SURFACE CONDITION	0.85 ~ 12S	
温度 TEMPERATURE	11℃	
検査条件 TEST CONDITION		
検査方法 METHOD	COLOR CONTRAST SOLVENT REMOVAL	
浸透時間 PENETRANT TIME	OVER 20 MINUTES	
現像時間 DEVELOPMENT TIME	10 MINUTES	
浸透液 PENETRANT	TASETO Co.,Ltd 14D-966018 FP-S	
洗浄液 REMOVER	TASETO Co.,Ltd 150-118074 FR-Q	
現像液 DEVELOPER	TASETO Co.,Ltd [A]15D088 FD-S	
検査員 N.D.E.PERSONNEL	/ NDI-CLASS II	
判定 EVALUATION	ACCEPTED	

日本非破壊検査株式会社 NIHON NONDESTRUCTION INSPECTION CO., LTD.

Material Test for Casing

Casing materials	<input type="checkbox"/> FC300	<input type="checkbox"/> FCD450	<input type="checkbox"/> SCW480	<input type="checkbox"/> SCPL1
------------------	--------------------------------	---------------------------------	---------------------------------	--------------------------------

1. Scope

This procedure defines material tests of the pressure proof parts to be used for screw compressors. The material test should be carried out by the casing manufacturers.

The pressure proof parts are shown below;

Rotor casing, Suction cover, Bearing head, Unloader cylinder, Unloader cylinder cover, Balance piston Cover, Bearing cover, Seal Cover

2. Test Method

In accordance with JIS standards each test should be carried out at the casing manufacturer. A visual check is made of the finished pieces and confirm the submitted material test reports.

3. Acceptance Criteria

- 3.1 Japanese Industrial Standards(JIS) G 5501 : FC300 (equivalent to ASTM A 48 Class No.45)**
Japanese Industrial Standards(JIS) G 5502 : FCD450 (equivalent to ASTM A536 Grade 65-45-12)

3.1.1 Chemical composition

Based on the casing manufacturer's experience, chemical composition should comply with the mechanical properties described in 3.1.2.

3.1.2 Mechanical Properties

JIS G 5501 : FC300 (equivalent to ASTM A 48 Class No.45)

- A. Tensile test (JIS Z 2241) : 300 N/mm² or more
 B. Hardness test (JIS Z 2243) : 262 HB or less

JIS G 5502 : FCD450 (equivalent to ASTM A536 Grade 65-45-12)

- A. Tensile test (JIS Z 2241) : 450 N/mm² or more
 B. Hardness test (JIS Z 2243) :140~210 HB (Informative reference)

3.2 JIS G 5102 : SCW480 (equivalent to ASTM A 216 Grade WCB)

3.2.1 Chemical Composition (JIS G5102)

Chemical composition (%) SCW480						
C	Si	Mn	P	S	Ni	Cr
0.22 or less	0.80 or less	1.50 or less	0.04 or less	0.04 or less	0.50 or less	0.50 or less

3.2.2 Heat Treatment

Based on the casing manufacturer's experience, the heat treatment should comply with the mechanical properties described in 3.2.3.

3.2.3 Mechanical Properties

- A. Tensile test (JIS Z 2241) : 480 N/mm² or more
- B. Impact test (JIS Z 2242) : 27 J or more (at 0°C)

3.3 JIS G 5152 : SCPL1 (equivalent to ASTM A 352 Grade LCB)**3.3.1 Chemical Composition (JIS G5152)**

Chemical composition (%) SCPL1								
C	Si	Mn	P	S	Ni	Mo	Cu	Cr
0.30 or less	0.60 or less	1.00 or less	0.04 or less	0.04 or less	---	---	0.5 or less	0.25 or less

3.3.2 Heat Treatment

Based on the casing manufacturer's experience, the heat treatment should comply with the mechanical properties described in 3.3.3.

3.3.3 Mechanical Properties

- A. Tensile test (JIS Z 2241) : 450 N/mm² or more
- B. Impact test (JIS Z 2242) :
The average value of three time measurements (at -45 °C) is 18 J or more, or the value of one time measurement (at -45 °C) is 14 J or more.

4. Records

The test results are recorded on the submitted documents such as Certificate of materials and Result of material test from the casing manufacturer. According to the casing manufacturer's criteria, markings (the name of manufacturer and the date) are applied.

Screw Compressors Standard Inspection Procedures
Document No. : SCSD-006-03
NDE for Casing : Penetrant Test

Moriya Plant, Mayekawa Mfg. Co., Ltd.

03	2019/07/08	Iisaka	Koizumi	Kato	Correction
02	2016/04/01	Suzukawa	Sasaki	Kawasaki	Review and revised
01	2011/07/01	Sasaki	Ikehara	Shozu	Review and revised
00	06/05/06	Ikehara	Amada	Koizumi	Newly created
Revision	Date	Created by	Confirmed by	Approved by	Description

NDE for Casing

Casing materials	<input type="checkbox"/> FC300	<input type="checkbox"/> FCD450	<input type="checkbox"/> SCW480	<input type="checkbox"/> SCPL1
------------------	--------------------------------	---------------------------------	---------------------------------	--------------------------------

1. Scope

This procedure defines the non-destructive examination of pressure proof parts to be used in screw compressors, carried out by an inspection organization.

2. Penetrant Test

According to "Non-destructive testing -- Penetrant testing -- Part 1: General principles -- Method for liquid penetrant testing and classification of the penetrant indication, JIS Z 2343-1(2001)", Penetrant tests are carried out by the inspection organization. Testing locations are shown by the arrows in figures 1 to 8. Submitted test reports and finished pieces are checked by visual inspection.

3. Acceptance criteria

Stipulated in JIS Z2343-1:2001 and the High Pressure Gas Safety Act, Designated Equipment Inspection Regulations.

Types of defects	Criteria	Remarks
1. Penetrant indication of cracks	There is no penetrant indication of cracks	-Linear penetrant indication: Length exceeds 3 times width.
2. Independent Penetrant Indication 1) Linear indication 2) Circular indication	4mm or less 4mm or less	-Circular penetrant indication: Any penetrant indication other than linear penetrant indication.
3. Continuous penetrant indication	The flaw mark to be 12 or less within 2,500 mm ² . The flaw mark is calculated as the sum of the products of the number of defects on the following table and the corresponding factor shown.	-Continuous Penetrant indication: Multiple penetrant indications roughly in line and the distance of each is 2 mm or less.
4. Dispersed Penetrant indication		-Dispersed penetrant indication: Multiple indications spread in a constant area.

Factor table

Defect indication	Max. Length. or Diameter 2mm or less	Max. Length. Or Diameter 4mm or less
Linear Penetrant indication	3	6
Circular Penetrant indication	1	2

4. Records

The test results are recorded in the document Liquid Penetrant Examination.

Penetrant test locations shown in figures below

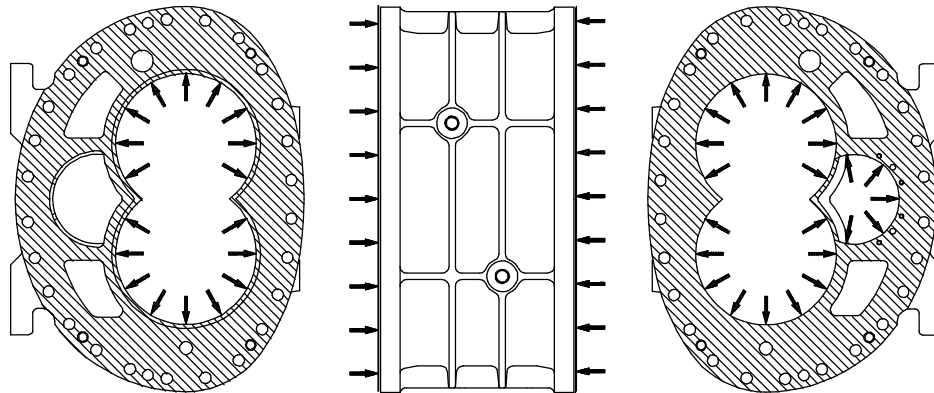

Figure-1 Rotor Casing

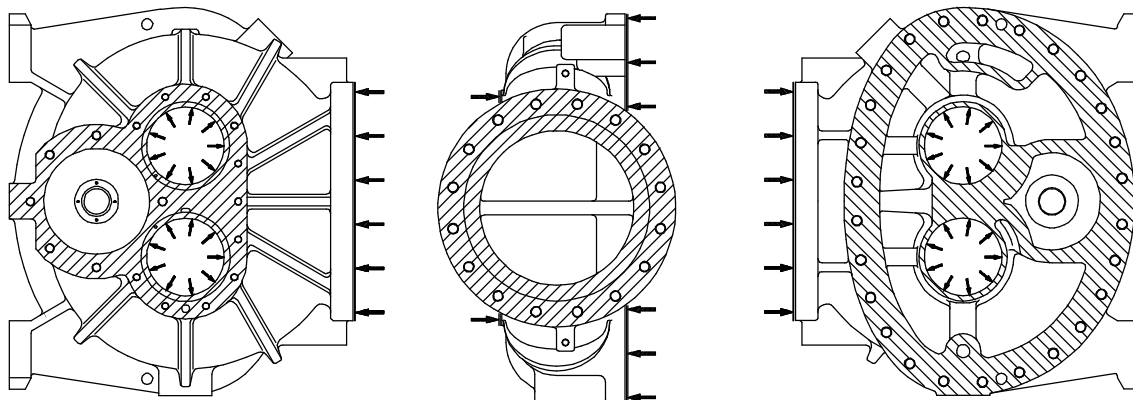

Figure-2 Suction Cover

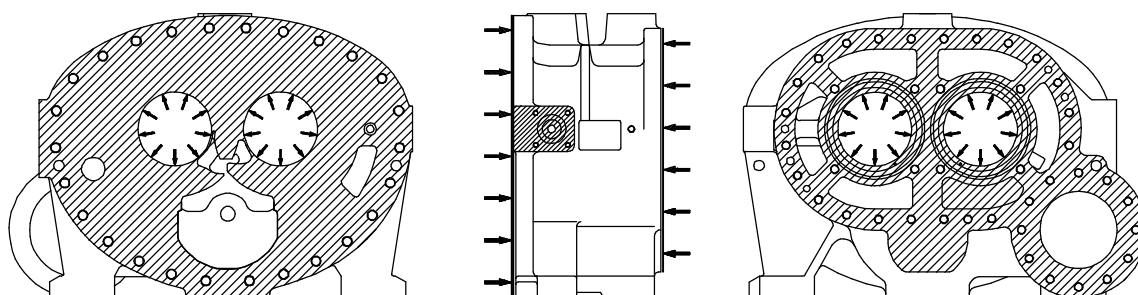

Figure-3 Bearing Head

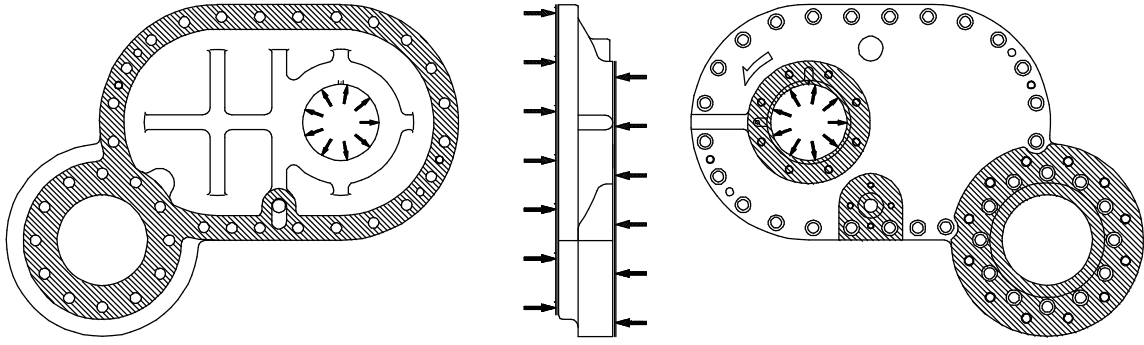

Figure-4 Bearing Cover

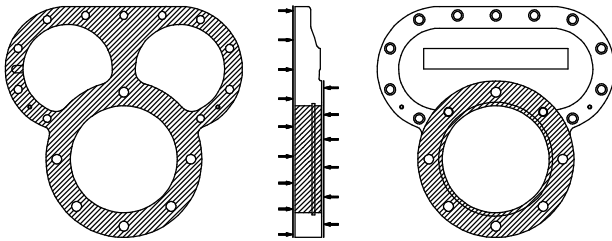

Figure-5 Balance Piston Cover

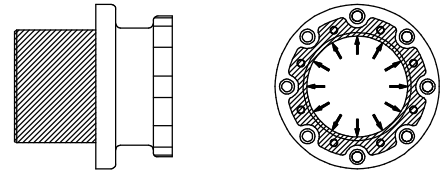

Figure-6 Unloader Cylinder

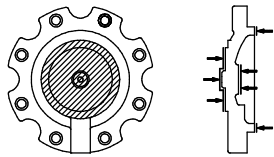

Figure-7 Unloader Cover

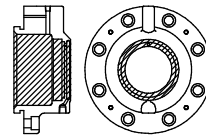

Figure-8 Seal Cover

SAMPLE

ITEM No.	浸透探傷検査報告書		試験-検査記録
製造番号 SERIAL No. 4035067	LIQUID PENETRANT EXAMINATION		日付 DATE September 17, 2013
注文主 CLIENT			
工事名称 JOB NAME	Screw Compressor Model: G400MUD-M		
検査場所 PLACE	MITSUBISHI KAWA MFG. CO. LTD. MORIYA FACTORY		
部品名称 / (チャージ No.) PARTS NAME / (Charge No.)	Rotor Casing (K0670), Station Cover (K0670), Bearing Housing (K0674) Bearing Cover (K0670), Balance Rotor (K0670) Seal Cover (K0670), Seal Cover (K0670)		
検査箇所 TEST SECTION	ALL EXTERNAL SURFACE		
材質 MATERIAL	JIS G 5152 SCPL11		
合格基準 ACCEPTANCE STANDARD	JIS Z 2343-1 Type of defects Indication by cracks Liner defects indication Circular defects indication Distributed defects indication Criterion : There is no indication by cracks. : 4mm or less : 4mm or less : The flaw mark to be 12 or less within 2500mm ²		
表面状態 SURFACE CONDITION	0.85 ~ 12S		
温度 TEMPERATURE	14℃		
検査条件 TEST CONDITION			
検査方法 METHOD	COLOR CONTRAST SOLVENT REMOVAL		
浸透時間 PENETRANT TIME	OVER 20 MINUTES		
現像時間 DEVELOPMENT TIME	10 MINUTES		
浸透液 PENETRANT	TASETO Co., Ltd. 14D-966018 FP-S		
洗淨液 REMOVER	TASETO Co., Ltd. 150-118074 FR-Q		
現像液 DEVELOPER	TASETO Co., Ltd. [A]15D088 FD-S		
検査員 N.D.E PERSONNEL	/ NDI-CLASS II		
判定 EVALUATION	ACCEPTED		

日本非破壊検査株式会社 NIHON NONDESTRUCTION INSPECTION CO., LTD.

Screw Compressor Standard Inspection Procedures

Document No. : SCSD-007-08

Screw Rotor Dynamic Balance Test

Moriya Plant, Mayekawa Mfg. Co., Ltd.

08	2021/12/09	Saka	Kato	Koizumi	Revised the reference value
07	2020/06/29	Sakaguchi	kato	Koizumi	400XXL added
06	2017/07/12	Iisaka	Sasaki	Kawasaki	Changed of equipment manufacturer company name
05	2016/06/10	Iisaka	Sasaki	Kawasaki	W series added
04	2014/04/01	Suzukawa	Sasaki	Sakaguchi	Review and revised
03	2013/05/01	Suzukawa	Sasaki	Shozu	Review and revised
02	2012/05/01	Suzukawa	Sasaki	Shozu	J series added
01	2011/07/01	Sasaki	Ikehara	Shozu	Review and revised
00	06/06/05	Ikehara	Amada	Koizumi	Newly created
Revision	Date	Created by	Confirmed by	Approved by	Description

Screw Rotor Dynamic Balance Test

1. Scope

Rotor dynamic balance test is carried out to check whether the compressor's rotor dynamic balance is within the standard value of the standard "Rotating machines - Balance quality requirement of rigid rotors"(JIS B 0905-1992).

2. Dynamic Balance Test

2.1 Method of Dynamic Balance Test

Rotor dynamic balance is measured at two points on each rotor using a screw rotor balancing machine.

Measuring points (see the figures below)

Male rotor At points A and B

Female rotor At points C and D

[Male rotor]

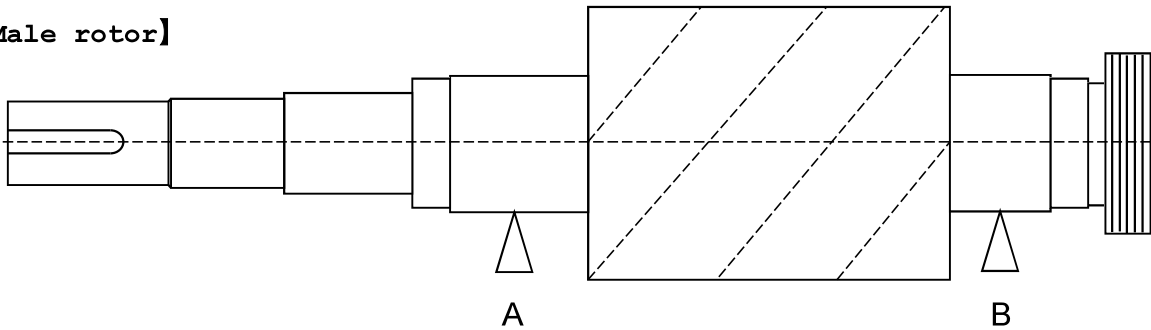

[Female rotor]

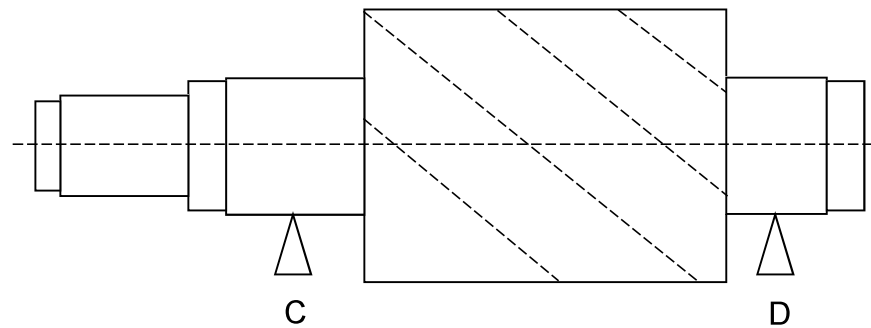

2.2 Measuring equipment

Manufacturer	Measuring equipment	Model
NAGAHAMA SEISAKUSHO LTD.,	Dynamic balancing machine	H40U H20NB

3. Acceptance Criteria

The acceptance criteria is as per JIS B 0905 Class G2.5 or Class 1.0 and the measured values must not exceed these criteria. Refer to the following tables as the standard values differ from rotor materials.

Rotor Material	<input type="checkbox"/> FCD600	<input type="checkbox"/> SFCM930S	<input type="checkbox"/> SFCM740S
Balance class	<input type="checkbox"/> Class G2.5		<input type="checkbox"/> Class G1.0

3.1.1 JIS G 5502 : FCD600 (Ductile Iron) JIS B 0905 Class G2.5 < Single stage compressor >

Model	Male rotor			Female rotor			Test speed
	Standard value		Max. speed	Standard value		Max. speed	
	g	g·cm	min-1	g	g·cm	min-1	min-1
125S	0.7	3.7	4500	0.8	4.2	3000	1265
125L	0.9	4.8	4500	1.0	5.6	3000	1265
160S	1.0	7.6	4500	1.2	8.8	3000	1265
160M	1.2	8.8	4500	1.4	10.3	3000	1265
160L	1.4	10.0	4500	1.6	11.7	3000	1265
200S	1.6	14.2	4500	1.8	16.6	3000	1265
200M	1.8	16.6	4500	2.2	19.4	3000	1265
200L	2.1	18.8	4500	2.5	22.2	3000	1265
250S	2.4	26.8	4500	2.9	31.7	3000	750
250M	2.9	31.4	4500	3.4	37.4	3000	750
250L	3.3	35.8	4500	3.9	42.7	3000	750
250LL	4.7	51.8	3600	5.7	62.8	2400	750
320S	4.9	68.1	3600	5.8	80.6	2400	430
320M	5.7	79.3	3600	6.7	94.3	2400	430
320L	6.5	90.4	3600	7.7	107.8	2400	430
320LL	7.5	104.3	3600	9.0	126.3	2400	430
400S	8.3	145.6	3600	9.9	173.2	2400	430
400M	9.7	169.2	3600	11.5	201.9	2400	430
400L	10.9	191.4	3600	13.1	228.9	2400	430
400LL	12.4	216.4	3600	14.8	259.4	2400	430
400XL	13.6	237.3	3600	16.3	284.9	2400	430
400XXL	14.9	261.1	3600	17.9	313.9	2400	430
160WS	1.1	7.7	4500	1.2	9.0	3000	1265
160WM	1.2	8.9	4500	1.4	10.4	3000	1265
160WL	1.4	10.1	4500	1.6	11.8	3000	1265
200WS	1.6	14.5	4500	1.9	16.8	3000	1265
200WM	1.9	16.8	4500	2.2	19.6	3000	1265
200WL	2.1	19.1	4500	2.5	22.4	3000	1265
250WS	2.5	27.5	4500	3.0	33.3	3000	750
250WM	2.9	32.1	4500	3.5	38.9	3000	750
250WL	3.3	36.5	4500	4.0	44.2	3000	750
320WS	5.0	69.7	3600	6.0	84.2	2400	430
320WM	5.8	80.9	3600	7.0	97.8	2400	430
320WL	6.6	92.0	3600	7.9	111.3	2400	430

Continued on the following page

Model	Male rotor			Female rotor			Test speed
	Standard value		Max. speed	Standard value		Max. speed	
	g	g·cm	min-1	g	g·cm	min-1	min-1
170JS	1.3	9.8	4500	1.0	6.0	3750	1265
170JM	1.6	11.4	4500	1.1	7.0	3750	1265
170JL	1.9	13.5	4500	1.4	8.6	3750	1265
220JS	2.5	23.3	4500	1.8	14.6	3750	1265
220JM	2.9	27.6	4500	2.1	17.5	3750	1265
220JL	3.5	32.9	4500	2.6	21.3	3750	1265
280JS	5.2	64.3	3600	3.8	40.2	3000	750
280JM	6.1	75.6	3600	4.5	48.1	3000	750
280JL	7.3	90.2	3600	5.6	58.9	3000	750
i125S	0.6	3.5	4500	0.7	3.7	3000	1265
i125L	1.1	5.8	3550	1.2	6.5	2367	1265
i160S	0.9	6.8	4500	1.1	8.0	3000	1265
i160M	1.4	10.2	3550	1.6	12.0	2367	1265
i160L	1.6	11.8	3550	1.9	13.8	2367	1265

3.1.2 JIS G 5502 : FCD600 (Ductile Iron) JIS B 0905 Class G1.0 < Single stage compressor >

Model	Male rotor			Female rotor			Test speed
	Standard value		Max. speed	Standard value		Max. speed	
	g	g·cm	min-1	g	g·cm	min-1	min-1
160S	0.4	3.0	4500	0.5	3.5	3000	1265
160M	0.5	3.5	4500	0.6	4.1	3000	1265
160L	0.5	4.0	4500	0.6	4.7	3000	1265
200S	0.6	5.7	4500	0.7	6.6	3000	1265
200M	0.7	6.6	4500	0.9	7.8	3000	1265
200L	0.8	7.5	4500	1.0	8.9	3000	1265
250S	1.0	10.7	4500	1.2	12.7	3000	750
250M	1.1	12.6	4500	1.4	14.9	3000	750
250L	1.3	14.3	4500	1.6	17.1	3000	750
250LL	1.9	20.7	3600	2.3	25.1	2400	750
320S	1.9	27.2	3600	2.3	32.3	2400	430
320M	2.3	31.7	3600	2.7	37.7	2400	430
320L	2.6	36.1	3600	3.1	43.1	2400	430
320LL	3.0	41.7	3600	3.6	50.5	2400	430

Continued on the following page

Model	Male rotor			Female rotor			Test speed
	Standard value		Max. speed	Standard value		Max. speed	
	g	g·cm	min-1	g	g·cm	min-1	min-1
400S	3.3	58.2	3600	4.0	69.3	2400	430
400M	3.9	67.7	3600	4.6	80.8	2400	430
400L	4.4	76.5	3600	5.2	91.6	2400	430
400LL	4.9	86.6	3600	5.9	103.8	2400	430
400XL	5.4	94.9	3600	6.5	114.0	2400	430
400XXL	6.0	104.4	3600	7.2	125.6	2400	430
160WS	0.4	3.1	4500	0.5	3.6	3000	1265
160WM	0.5	3.6	4500	0.6	4.2	3000	1265
160WL	0.6	4.0	4500	0.6	4.7	3000	1265
200WS	0.6	5.8	4500	0.7	6.7	3000	1265
200WM	0.7	6.7	4500	0.9	7.8	3000	1265
200WL	0.8	7.6	4500	1.0	8.9	3000	1265
250WS	1.0	11.0	4500	1.2	13.3	3000	750
250WM	1.2	12.8	4500	1.4	15.6	3000	750
250WL	1.3	14.6	4500	1.6	17.7	3000	750
320WS	2.0	27.9	3600	2.4	33.7	2400	430
320WM	2.3	32.4	3600	2.8	39.1	2400	430
320WL	2.6	36.8	3600	3.2	44.5	2400	430

3.1.3 JIS G 3221 : SFCM930S, SFMC740S (Forged steel) JIS B 0905 Class G2.5

< Single stage compressor >

Model	Male rotor			Female rotor			Test speed
	Standard value		Max. speed	Standard value		Max. speed	
	g	g·cm	min-1	g	g·cm	min-1	min-1
125S	0.7	4.1	4500	0.8	4.6	3000	1265
125L	1.0	5.3	4500	1.1	6.2	3000	1265
160S	1.1	8.4	4500	1.3	9.7	3000	1265
160M	1.3	9.7	4500	1.6	11.3	3000	1265
160L	1.5	11.0	4500	1.8	12.9	3000	1265
200S	1.7	15.7	4500	2.0	18.3	3000	1265
200M	2.0	18.3	4500	2.4	21.4	3000	1265
200L	2.3	20.8	4500	2.7	24.5	3000	1265
250S	2.7	29.6	4500	3.2	35.0	3000	750
250M	3.2	34.7	4500	3.7	41.2	3000	750
250L	3.6	39.5	4500	4.3	47.1	3000	750
250LL	5.2	57.1	3600	6.3	69.3	2400	750

Continued on the following page

Model	Male rotor			Female rotor			Test speed
	Standard value		Max. speed	Standard value		Max. speed	
	g	g·cm	min-1	g	g·cm	min-1	min-1
320S	5.4	75.1	3600	6.4	88.9	2400	430
320M	6.2	87.5	3600	7.4	104.0	2400	430
320L	7.1	99.7	3600	8.5	118.8	2400	430
320LL	8.2	115.1	3600	10.0	139.3	2400	430
400S	9.2	160.6	3600	10.9	191.0	2400	430
400M	10.7	186.6	3600	12.7	222.7	2400	430
400L	12.1	211.0	3600	14.4	252.5	2400	430
400LL	13.6	238.6	3600	16.3	286.1	2400	430
400XL	15.0	261.7	3600	18.0	314.2	2400	430
400XXL	16.5	288.0	3600	19.8	346.2	2400	430
160WS	1.2	8.5	4500	1.4	9.9	3000	1265
160WM	1.3	9.8	4500	1.6	11.5	3000	1265
160WL	1.5	11.1	4500	1.8	13.0	3000	1265
200WS	1.8	16.0	4500	2.1	18.5	3000	1265
200WM	2.1	18.5	4500	2.4	21.6	3000	1265
200WL	2.3	21.0	4500	2.7	24.7	3000	1265
250WS	2.8	30.3	4500	3.3	36.7	3000	750
250WM	3.2	35.4	4500	3.9	42.9	3000	750
250WL	3.7	40.2	4500	4.4	48.8	3000	750
320WS	5.5	76.9	3600	6.6	92.8	2400	430
320WM	6.4	89.3	3600	7.7	107.9	2400	430
320WL	7.2	101.5	3600	8.8	122.7	2400	430

3.1.4 JIS G 3221 : SFMC930S, SFMC740S (Forged steel) JIS B 0905 Class G1.0

< Single stage compressor >

Model	Male rotor			Female rotor			Test speed
	Standard value		Max. speed	Standard value		Max. speed	
	g	g·cm	min-1	g	g·cm	min-1	min-1
160S	0.5	3.4	4500	0.5	3.9	3000	1265
160M	0.5	3.9	4500	0.6	4.5	3000	1265
160L	0.6	4.4	4500	0.7	5.2	3000	1265
200S	0.7	6.3	4500	0.8	7.3	3000	1265
200M	0.8	7.3	4500	1.0	8.6	3000	1265
200L	0.9	8.3	4500	1.1	9.8	3000	1265

Continued on the following page

Model	Male rotor			Female rotor			Test speed
	Standard value		Max. speed	Standard value		Max. speed	
	g	g·cm	min-1	g	g·cm	min-1	min-1
250S	1.1	11.8	4500	1.3	14.0	3000	750
250M	1.3	13.9	4500	1.5	16.5	3000	750
250L	1.4	15.8	4500	1.7	18.8	3000	750
250LL	2.1	22.8	3600	2.5	27.7	2400	750
320S	2.1	30.0	3600	2.5	35.6	2400	430
320M	2.5	35.0	3600	3.0	41.6	2400	430
320L	2.8	39.9	3600	3.4	47.5	2400	430
320LL	3.3	46.0	3600	4.0	55.7	2400	430
400S	3.7	64.2	3600	4.4	76.4	2400	430
400M	4.3	74.6	3600	5.1	89.1	2400	430
400L	4.8	84.4	3600	5.8	101.0	2400	430
400LL	5.5	95.5	3600	6.5	114.4	2400	430
400XL	6.0	104.7	3600	7.2	125.7	2400	430
400XXL	6.6	115.2	3600	7.9	138.5	2400	430
160WS	0.5	3.4	4500	0.5	3.9	3000	1265
160WM	0.5	3.9	4500	0.6	4.6	3000	1265
160WL	0.6	4.5	4500	0.7	5.2	3000	1265
200WS	0.7	6.4	4500	0.8	7.4	3000	1265
200WM	0.8	7.4	4500	1.0	8.6	3000	1265
200WL	0.9	8.4	4500	1.1	9.9	3000	1265
250WS	1.1	12.1	4500	1.3	14.7	3000	750
250WM	1.3	14.2	4500	1.6	17.2	3000	750
250WL	1.5	16.1	4500	1.8	19.5	3000	750
320WS	2.2	30.8	3600	2.7	37.1	2400	430
320WM	2.6	35.7	3600	3.1	43.1	2400	430
320WL	2.9	40.6	3600	3.5	49.1	2400	430

3.2.1 JIS G 5502 : FCD600 (Ductile Iron) JIS B 0905 Class G2.5

< Compound two-stage compressor >

Model			Male rotor			Female rotor			Test speed
			Standard value		Max. speed	Standard		Max. speed	
			g	g·cm	min-1	g	g·cm	min-1	min-1
1610	low stage	S	1.1	7.9	4000	1.2	9.0	2667	1265
	high stage	L	0.7	2.9	4000	0.8	3.6	2667	1265

Continued on the following page

Model			Male rotor			Female rotor			Test speed
			Standard value		Max. speed	Standard value		Max. speed	
			g	g·cm	min-1	g	g·cm	min-1	min-1
1612	low stage *1 : Mounted on speed-up gear	S	1.0	7.1	4500	1.1	8.0	3000	1265
		M	1.1	8.3	4500	1.3	9.4	3000	1265
		L	1.3	9.5	4500	1.5	10.9	3000	1265
		L* ¹	1.3	9.6	4500	1.5	10.9	3000	1265
	high stage	S	0.6	3.2	4500	0.7	4.0	3000	1265
		L	0.8	4.3	4500	1.0	5.4	3000	1265
2016	low stage	S	1.7	15.3	4000	2.0	18.3	2667	1265
		M	2.0	17.9	4000	2.4	21.5	2667	1265
		L	2.3	20.5	4000	2.7	24.6	2667	1265
	high stage	S	1.0	7.6	4000	1.3	9.4	2667	1265
		M	1.2	8.9	4000	1.5	11.0	2667	1265
		L	1.4	10.2	4000	1.7	12.6	2667	1265
2520	low stage	S	3.0	32.8	3600	3.6	39.7	2400	750
		M	3.5	38.5	3600	4.2	46.7	2400	750
		L	4.0	44.0	3600	4.8	53.3	2400	750
	high stage	S	1.9	16.9	3600	2.3	20.7	2400	1265
		M	2.2	19.9	3600	2.7	24.3	2400	1265
		L	2.5	22.7	3600	3.1	27.7	2400	1265
		WS	1.9	17.3	3600	2.3	20.9	2400	1265
3225	low stage	S	4.7	66.3	3600	5.8	80.6	2400	430
		M	5.5	77.5	3600	6.7	94.3	2400	430
		L	6.3	88.6	3600	7.7	107.8	2400	430
		LL	7.2	100.9	3600	8.8	122.8	2400	430
	high stage	S	2.9	31.6	3600	3.5	38.9	2400	750
		M	3.4	37.4	3600	4.2	45.9	2400	750
		L	3.9	42.9	3600	4.8	52.6	2400	750
		WS	3.0	32.5	3600	3.7	40.8	2400	750
		WM	3.5	38.3	3600	4.4	47.9	2400	750
		WL	4.0	43.7	3600	5.0	54.5	2400	750

Continued on the following page

Model			Male rotor			Female rotor			Test speed
			Standard value		Max. speed	Standard		Max. speed	
			g	g·cm	min-1	g	g·cm	min-1	min-1
4032	low stage	S	8.1	142.4	3600	9.9	173.2	2400	430
		M	9.5	166.0	3600	11.5	201.9	2400	430
		L	10.8	188.2	3600	13.1	228.9	2400	430
		LL	12.2	213.2	3600	14.8	259.4	2400	430
		XL	13.4	234.1	3600	16.3	284.9	2400	430
	high stage	S	4.7	65.2	3600	5.8	80.6	2400	430
		M	5.5	76.4	3600	6.7	94.3	2400	430
		L	6.2	87.5	3600	7.7	107.8	2400	430
		LL	7.2	101.5	3600	9.0	126.3	2400	430
		WS	4.8	66.9	3600	6.0	84.2	2400	430
		WM	5.6	78.1	3600	7.0	97.8	2400	430
		WL	6.4	89.1	3600	7.9	111.3	2400	430

3.2.2 JIS G 5502 : FCD600 (Ductile Iron) JIS B 0905 Class G1.0

< Compound two-stage compressor >

Model			Male rotor			Female rotor			Test speed
			Standard value		Max. speed	Standard		Max. speed	
			g	g·cm	min-1	g	g·cm	min-1	min-1
1610	low stage	S	0.4	3.1	4000	0.5	3.6	2667	1265
1612	low stage *1 : Mounted on speed-up gear	S	0.4	2.8	4500	0.4	3.2	3000	1265
		M	0.5	3.3	4500	0.5	3.8	3000	1265
		L	0.5	3.8	4500	0.6	4.3	3000	1265
		L*1	0.5	3.9	4500	0.6	4.3	3000	1265
2016	low stage	S	0.7	6.1	4000	0.8	7.3	2667	1265
		M	0.8	7.2	4000	1.0	8.6	2667	1265
		L	0.9	8.2	4000	1.1	9.9	2667	1265
	high stage	S	0.4	3.0	4000	0.5	3.8	2667	1265
		M	0.5	3.6	4000	0.6	4.4	2667	1265
		L	0.6	4.1	4000	0.7	5.1	2667	1265

Continued on the following page

Model		Male rotor			Female rotor			Test	
		Standard value		Max. speed	Standard		Max. speed	speed	
		g	g·cm	min-1	g	g·cm	min-1	min-1	
2520	low stage	S	1.2	13.1	3600	1.4	15.9	2400	750
		M	1.4	15.4	3600	1.7	18.7	2400	750
		L	1.6	17.6	3600	1.9	21.3	2400	750
	high stage	S	0.8	6.8	3600	0.9	8.3	2400	1265
		M	0.9	7.9	3600	1.1	9.7	2400	1265
		L	1.0	9.1	3600	1.2	11.1	2400	1265
		WS	0.8	6.9	3600	0.9	8.4	2400	1265
3225	low stage	S	1.9	26.5	3600	2.3	32.3	2400	430
		M	2.2	31.0	3600	2.7	37.7	2400	430
		L	2.5	35.4	3600	3.1	43.1	2400	430
		LL	2.9	40.4	3600	3.5	49.1	2400	430
	high stage	S	1.2	12.7	3600	1.4	15.6	2400	750
		M	1.4	15.0	3600	1.7	18.4	2400	750
		L	1.6	17.1	3600	1.9	21.0	2400	750
		WS	1.2	13.0	3600	1.5	16.3	2400	750
		WM	1.4	15.3	3600	1.7	19.2	2400	750
		WL	1.6	17.5	3600	2.0	21.8	2400	750
4032	low stage	S	3.3	57.0	3600	4.0	69.3	2400	430
		M	3.8	66.4	3600	4.6	80.8	2400	430
		L	4.3	75.3	3600	5.2	91.6	2400	430
		LL	4.9	85.3	3600	5.9	103.8	2400	430
		XL	5.4	93.7	3600	6.5	114.0	2400	430
	high stage	S	1.9	26.1	3600	2.3	32.3	2400	430
		M	2.2	30.6	3600	2.7	37.7	2400	430
		L	2.5	35.0	3600	3.1	43.1	2400	430
		LL	2.9	40.6	3600	3.6	50.5	2400	430
		WS	1.9	26.7	3600	2.4	33.7	2400	430
		WM	2.2	31.2	3600	2.8	39.1	2400	430
		WL	2.5	35.6	3600	3.2	44.5	2400	430

3.2.3 JIS G 3221 : SFCM930S, SFCM740S (Forged steel) JIS B 0905 Class G2.5

< Compound two-stage compressor >

Model			Male rotor			Female rotor			Test speed	
			Standard value		Max. speed	Standard		Max. speed		
			g	g·cm	min-1	g	g·cm	min-1	min-1	
1610	low stage	S	1.2	8.7	4000	1.4	9.9	2667	1265	
	high stage	L	0.7	3.2	4000	0.9	3.9	2667	1265	
1612	low stage	S	1.1	7.8	4500	1.2	8.8	3000	1265	
		*1 : Mounted on speed-up gear	M	1.3	9.2	4500	1.4	10.4	3000	1265
		L	1.4	10.5	4500	1.6	12.0	3000	1265	
	high stage	L*1	1.5	10.6	4500	1.6	12.0	3000	1265	
		S	0.6	3.6	4500	0.8	4.4	3000	1265	
		L	0.9	4.8	4500	1.1	5.9	3000	1265	
2016	low stage	S	1.9	16.9	4000	2.2	20.2	2667	1265	
		M	2.2	19.8	4000	2.6	23.8	2667	1265	
		L	2.5	22.6	4000	3.0	27.2	2667	1265	
	high stage	S	1.1	8.4	4000	1.4	10.4	2667	1265	
		M	1.3	9.8	4000	1.7	12.2	2667	1265	
		L	1.5	11.3	4000	1.9	13.9	2667	1265	
2520	low stage	S	3.3	36.1	3600	4.0	43.7	2400	750	
		M	3.9	42.5	3600	4.7	51.5	2400	750	
		L	4.4	48.5	3600	5.3	58.8	2400	750	
	high stage	S	2.1	18.7	3600	2.5	22.9	2400	1265	
		M	2.4	21.9	3600	3.0	26.8	2400	1265	
		L	2.8	25.0	3600	3.4	30.6	2400	1265	
WS	2.1	19.1	3600	2.6	23.1	2400	1265			
3225	low stage	S	5.2	73.2	3600	6.4	88.9	2400	430	
		M	6.1	85.5	3600	7.4	104.0	2400	430	
		L	7.0	97.7	3600	8.5	118.8	2400	430	
		LL	8.0	111.3	3600	9.7	135.4	2400	430	
	high stage	S	3.2	34.9	3600	3.9	42.9	2400	750	
		M	3.8	41.3	3600	4.6	50.7	2400	750	
		L	4.3	47.3	3600	5.3	58.0	2400	750	
		WS	3.3	35.8	3600	4.1	45.0	2400	750	
		WM	3.8	42.2	3600	4.8	52.8	2400	750	
		WL	4.4	48.2	3600	5.5	60.1	2400	750	

Continued on the following page

Model			Male rotor			Female rotor			Test
			Standard value		Max. speed	Standard		Max. speed	speed
			g	g·cm	min-1	g	g·cm	min-1	min-1
4032	low stage	S	9.0	157.1	3600	10.9	191.0	2400	430
		M	10.5	183.1	3600	12.7	222.7	2400	430
		L	11.9	207.5	3600	14.4	252.5	2400	430
		LL	13.4	235.1	3600	16.3	286.1	2400	430
		XL	14.8	258.2	3600	18.0	314.2	2400	430
	high stage	S	5.1	71.9	3600	6.4	88.9	2400	430
		M	6.0	84.3	3600	7.4	104.0	2400	430
		L	6.9	96.5	3600	8.5	118.8	2400	430
		LL	8.0	111.9	3600	10.0	139.3	2400	430
		WS	5.3	73.7	3600	6.6	92.8	2400	430
		WM	6.1	86.1	3600	7.7	107.9	2400	430
		WL	7.0	98.3	3600	8.8	122.7	2400	430

3.2.4 JIS G 3221 : SFCM930S, SFCM740S (Forged steel) JIS B 0905 Class G1.0

< Compound two-stage compressor >

Model			Male rotor			Female rotor			Test
			Standard value		Max. speed	Standard		Max. speed	speed
			g	g·cm	min-1	g	g·cm	min-1	min-1
1610	low stage	S	0.5	3.5	4000	0.5	4.0	2667	1265
1612	low stage *1 : Mounted on speed-up gear	S	0.4	3.1	4500	0.5	3.5	3000	1265
		M	0.5	3.7	4500	0.6	4.2	3000	1265
		L	0.6	4.2	4500	0.7	4.8	3000	1265
		L*1	0.6	4.3	4500	0.7	4.8	3000	1265
2016	low stage	S	0.7	6.7	4000	0.9	8.1	2667	1265
		M	0.9	7.9	4000	1.1	9.5	2667	1265
		L	1.0	9.0	4000	1.2	10.9	2667	1265
	high stage	S	0.5	3.3	4000	0.6	4.2	2667	1265
		M	0.5	3.9	4000	0.7	4.9	2667	1265
		L	0.6	4.5	4000	0.8	5.6	2667	1265
2520	low stage	S	1.3	14.5	3600	1.6	17.5	2400	750
		M	1.5	17.0	3600	1.9	20.6	2400	750
		L	1.8	19.4	3600	2.1	23.5	2400	750
	high stage	S	0.8	7.5	3600	1.0	9.1	2400	1265
		M	1.0	8.8	3600	1.2	10.7	2400	1265
		L	1.1	10.0	3600	1.4	12.2	2400	1265
		WS	0.8	7.6	3600	1.0	9.2	2400	1265

Continued on the following page

Model		Male rotor			Female rotor			Test	
		Standard value		Max. speed	Standard		Max. speed	speed	
		g	g·cm	min-1	g	g·cm	min-1	min-1	
3225	low stage	S	2.1	29.3	3600	2.5	35.6	2400	430
		M	2.4	34.2	3600	3.0	41.6	2400	430
		L	2.8	39.1	3600	3.4	47.5	2400	430
		LL	3.2	44.5	3600	3.9	54.2	2400	430
	high stage	S	1.3	14.0	3600	1.6	17.2	2400	750
		M	1.5	16.5	3600	1.8	20.3	2400	750
		L	1.7	18.9	3600	2.1	23.2	2400	750
		WS	1.3	14.3	3600	1.6	18.0	2400	750
		WM	1.5	16.9	3600	1.9	21.1	2400	750
		WL	1.8	19.3	3600	2.2	24.0	2400	750
4032	low stage	S	3.6	62.8	3600	4.4	76.4	2400	430
		M	4.2	73.2	3600	5.1	89.1	2400	430
		L	4.7	83.0	3600	5.8	101.0	2400	430
		LL	5.4	94.1	3600	6.5	114.4	2400	430
		XL	5.9	103.3	3600	7.2	125.7	2400	430
	high stage	S	2.1	28.8	3600	2.5	35.6	2400	430
		M	2.4	33.7	3600	3.0	41.6	2400	430
		L	2.8	38.6	3600	3.4	47.5	2400	430
		LL	3.2	44.8	3600	4.0	55.7	2400	430
		WS	2.1	29.5	3600	2.7	37.1	2400	430
		WM	2.5	34.4	3600	3.1	43.1	2400	430
		WL	2.8	39.3	3600	3.5	49.1	2400	430

4. Records

The test results and judgment are recorded on Appendix-1: MALE/FEMALE ROTOR BALANCING TEST REPORT.



Item No. -

Report No. 0
Serial No. 0

Rotor Balancing Test Report

Model No.	Material	Test Speed	Correction Radius
0	0	0	0

Allowable Residual Unbalance value = $\frac{0 \times 9550}{3600} \times \frac{M}{2} \times \frac{1}{10}$ Class : G 0 (JIS B 9905)

Male Rotor Weight (kg) : 0 Rotating Vibration : NAG 1/1000 CRACK
Female Rotor Weight (kg) : 0 Model : H4JU

Sample

MALE ROTOR

Rotor No.	Date
0	January 0, 1900

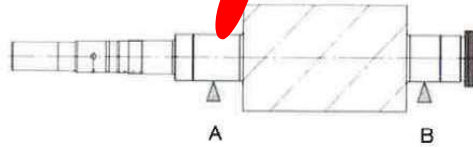

	Unbalanced Value at the Left Side (A)			Unbalanced Value at the Right Side (B)		
	(g)	Angle (°)	Value(g.cm)	(g)	Angle (°)	Value(g.cm)
Allowable Residual Unbalance	---	---	0	---	---	0
Before Adjustment	0.000	0	0.0	0.000	0	0.0
After Adjustment	---	---	---	---	---	---

FEMALE ROTOR

Rotor No.	Date
0	January 0, 1900

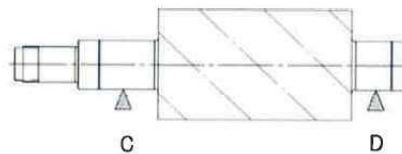

	Unbalanced Value at the Left Side (C)			Unbalanced Value at the Right Side (D)		
	(g)	Angle (°)	Value(g.cm)	(g)	Angle (°)	Value(g.cm)
Allowable Residual Unbalance	---	---	0	---	---	0
Before Adjustment	0.000	0	0.0	0.000	0	0.0
After Adjustment	---	---	---	---	---	---

Criteria Judgment : Accepted

SURVEYOR

Checked by : _____

Approved by : _____

Hydrostatic Test

1. Scope

This procedure defines the hydrostatic test performed at Moriya Plant, by the Compressor Manufacturing Division.

2. Hydrostatic test

2.1 Test Procedure

After assembling the compressor, it is filled with refrigeration oil.

The hydrostatic test is performed under the conditions shown in Table-1 for 30 minutes.

Table-1

Design pressure	2.6MPaG
Test pressure	3.9MPaG

Note: Two pressure gauges are used.

The test pressure is 1.5 times the design pressure.

The fluid used for the hydrostatic test is lubrication oil VG32 as standard.

3. Acceptance Criteria

The acceptance criterion is a visual inspection to ensure there are no distortions and leakages.

4. Records

The test results are recorded in Appendix-1:Hydrostatic & Pneumatic Tests Report.

[Appendix-1] **SAMPLE**

Hydrostatic & Pneumatic Tests Report

MYCOM

Report No. 0

Hydrostatic & Pneumatic Tests Report

Name of Client	
Type of Compressor	Screw Compressor
Compressor Model No.	0
Compressor Serial No.	0

TEST RECORD

Item	Design Pressure MPaG	Test Pressure MPaG	Used Fluid	Hold Time(Min)	Tested Date	Judgment
Hydrostatic test	2.6	3.9	OIL	30	March 13, 2012	Accepted
Pneumatic Pressure test	2.6	2.6	Air	30	December 31, 2012	Accepted

USED PRESSURE GAUGES

Item	Dia × Max. Pres. MPa.G	Manufacturer	Class(JIS)	No.
Hydrostatic test	φ 100 × 5.0	NAGANO	1.5	1, 2
Pneumatic Pressure test	φ 100 × 3.5	NAGANO	1.5	3, 4

Note :

MYCOM Control No.

AA-5.0100

AA-5.0103

3, AA-3.5001

4, AA-3.5002

SURVEYOR

Checked by : _____

Approved by : _____

MAYEKAWA MFG. CO.,LTD. Moriya Plant

Screw Compressor Standard Inspection Procedures
Document No. SCSD-009-02
Gas Leak Test

Moriya Plant, Mayekawa Mfg. Co., Ltd.

02	2016/11/21	Iisaka	Sasaki	Kawasaki	Title changed
01	2011/07/01	Sasaki	Ikehara	Shozu	Review and revised
00	2006/6/5	Ikehara	Amada	Koizumi	Newly created
Revision	Date	Created by	confirmed by	Approved by	Description

Gas Leak Test

1. Scope

This procedure defines the gas leak test performed at Moriya Plant, by the Compressor Manufacturing Division.

2. Gas Leak Test

2.1 Test procedure

The gas leak test should be performed after the hydrostatic test.

The gas leak test is performed under the conditions shown in Table-1 by submerging the compressor under water for 30 minutes.

Table-1

Design pressure	2.6MPaG
Test pressure	2.6MPaG

Note: Two pressure gauges are used.

The test pressure is the same as the design pressure.

The gas used for the gas leak test is dry air as standard.

3. Acceptance Criteria

The acceptance criterion is a visual inspection to ensure no air bubbles are evident.

4. Records

The test results are recorded in Appendix-1:Hydrostatic & Gas Leak Tests Report.

SAMPLE

Appendix-1:Hydrostatic & Gas Leak Tests Report

MYCOM

Report No. 0

Hydrostatic & Gas Leak Test Report

Item No.	-
Type of Compressor	Screw Compressor
Compressor Model No.	0
Compressor Serial No.	0

TEST RECORD

Item	Design Pressure MPaG	Test Pressure MPaG	Used Fluid	Hold Time(Min)	Tested Date	Judgment
Hydrostatic test	2.6	3.9	OIL	30		Accepted
Gas Leak test	2.6	2.6	Air	30		Accepted

USED PRESSURE GAUGES

Item	Dia × Max. Pres. MPa.G	Manufacturer	Class(JIS)	No.
Hydrostatic test	φ 100 × 7.0	NAGANO	1.5	1, 2
Gas Leak test	φ 100 × 5.0	NAGANO	1.5	3, 4

Note :

No.	Registration No.	Terms of validity
1	AA-70105	Feb,2017
2	AA-70107	Feb,2017
3	AA-50005	Oct,2016
4	AA-50006	Oct,2016

SURVEYOR

Checked by : _____

Approved by : _____

MAYEKAWA MFG. CO.,LTD Moriya Plant

Screw Compressor Standard Inspection Procedures

Document No. SCSD-010-10

Performance Test, Mechanical Running Test, Noise and Vibration Test

10	2020/06/16	Sakaguchi	Kato	Koizumi	400XXL added
09	2020/04/28	Saka Sakaguchi	Koizumi	Kato	Review and revised [6.2.3 Noise item]
08	2017/11/22	Suzukawa	Sasaki	Kawasaki	Review and revised
07	2017/03/30	Suzukawa	Sasaki	Kawasaki	Review and revised
06	2016/05/18	Iisaka	Sasaki	Kawasaki	Review and revised
05	2016/01/01	Suzukawa	Sasaki	Kawasaki	Review and revised
04	2015/02/17	Suzukawa	Sasaki	Kawasaki	Review and revised
03	2014/03/01	Suzukawa	Sasaki	Sakaguchi	Review and revised
02	2012/05/01	Suzukawa	Sasaki	Shozu	J series added
01	2011/07/01	Sasaki	Ikehara	Shozu	Review and revised
00	06/06/09	Ikehara	Amada	Koizumi	Newly created
Revision	Date	Created by	confirmed by	Approved by	Description

1. Scope

These procedures apply to the performance test, mechanical running test, vibration and noise tests of MYCOM screw compressors at the compressor manufacturing division of Mayekawa's Moriya plant, using air test equipment. The test fluid should be air. For equipment required for these tests such as couplings, motors, oil separators, cooler and measurement equipment, the test benches at the plant are used.

2. Applicable Models

	Model	Type	Manufacture d from	Remarks
1	UD/G series	125*U*/*G 320*U*/*U	~ 1970	Single stage compressor (side discharge, downward discharge)
2	SCV series	160V**~250V**	1991	Single stage compressor (side discharge, downward discharge)
3	SCV series	320V**	1998	Single stage compressor (side discharge, downward discharge)
4	VR series	160V*R	1996	Single stage compressor (with gear box)
5	Compound type two-stage compressor series	1610**C~3225**C	1975	
6	Compound type two-stage compressor series	4032**C	2001	
7	UD series	400*UD	2002	Single stage compressor (side discharge)
8	J series	170*J, 220J*, 280J*	2011	Single stage compressor

3. Tests

- 1) Performance test
 - capacity
 - brake horse power
- 2) Mechanical running test
- 3) Vibration and noise tests

4. Performance Test

[Capacity]

4.1 Purpose

This test is carried out to determine that the volume flow rate of suction gas at the inlet of the compressor and the brake horse power meet the criteria.

4.2 Measuring Method/Equipment and Test Conditions

In accordance with the JIS standard *Measurement of Fluid Flow by Means of Orifice Plates, Nozzles And Venturi Tubes* (JIS Z 8762:2007), we measure pressures and temperatures required for calculating the volume rate of flows from ① to ⑬ shown in the Figure-1:Test Equipment and Measurement Points using pressure gauge, manometer and thermometers. Performance measurement will be done during the mechanical running test.

The test fluid used for performance test and mechanical running test should be air. Testing is conducted under standard testing conditions (refer to Table-1). Motor revolution is controlled by 2950-3000 rpm (2P) or 1450-1500rpm (4P). Gears and the like are not used to increase the speed of the compressor.

The load operating conditions should be 100%, that is, the slide valve opening should be 100%.

The standard temperature of compressor lubrication oil should be 30°C to 50°C. The standard pressure of compressor lubrication oil on the discharge side is 0.2 to 0.3MPaG higher than the discharge pressure. When discharge pressure is 0.7 MPaG, then (with a tolerance of between 0.2 to 0.3) the standard pressure should be 0.9 to 1.0 MPaG.

Measurement equipment differs according to the test bench required for each compressor type. Refer to Appendix Table-2: Measurement Equipment List for details as reference.

Figure-1 : Test Equipment and Measurement Points

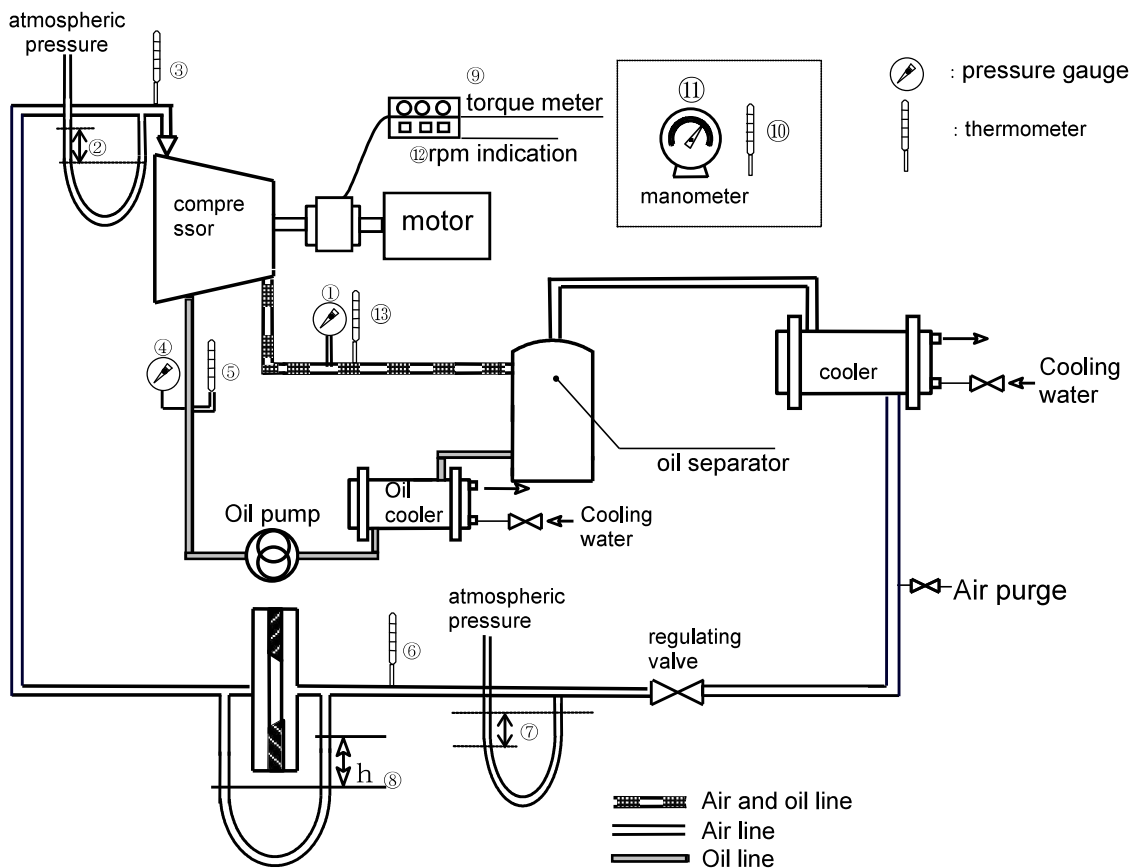

① : Discharge pressure	(MPaG)	⑧ : Orifice differential pressure	(kPa)
② : Suction pressure	(kPaG)	⑨ : Torque	(Nm)
③ : Suction temperature	(°C)	⑩ : Room temperature	(°C)
④ : Lubrication oil supply pressure	(MPaG)	⑪ : Atmospheric pressure	(hPa)
⑤ : Lubrication oil temperature	(°C)	⑫ : Motor revolution	(min ⁻¹)
⑥ : Temperature before orifice	(°C)	⑬ : Discharge temperature	(°C)
⑦ : Pressure before orifice	(kPaG)		

In addition intermediate temperature and intermediate pressure are measured for compound type compressors.

Unit : MPaG

Code	Classification	Suction pressure	Discharge pressure
F	Single stage type	Vi : 1.8	0. 0 0
J		Vi : 2.0	0. 0 0
K		Vi : 2.2	0. 0 0
L		Vi : 2.6	0. 0 0
M		Vi : 3.6	0. 0 0
H		Vi : 5.8	0. 0 0
C	Compound type	0. 0 0	0. 7 0
B	Booster type	0. 0 0	0. 3 0
DD	Slide Valve with groove	0. 0 0	0. 3 0

Note) Vi : design volume ratio

[Table-1:Standard pressure conditions]

4.3. Calculation of the Volume Flow Rate of Suction Gas

Calculate the volume ratio of suction gas flow before orifice (Qa) from formula (1) below using orifice differential pressure, pressure before orifice and temperature.

$$Q_a = \varepsilon \cdot \alpha \cdot \pi / 4 (dt \times 10^{-3})^2 \sqrt{2 \cdot \Delta H} \times 10^6 \times V_O \times 3600 \dots (1)$$

Qa	the volume flow rate of suction gas before orifice	(m ³ /h)
ε	expansibility factor	(--)
α	flow coefficient	(--)
dt	Diameter of orifice	(mm)
ΔH	Differential pressure around orifice plate	(MPa)
Vo	Gas specific volume before orifice	(m ³ /kg)

Calculate the volume ratio of flow of suction gas at compressor inlet (Qs) from formula (2) using gas volume ratio before the orifice and at the suction inlet.

$$Q_s = Q_a \times \frac{V_S}{V_O} \dots (2)$$

Qs	the volume flow rate of suction gas at the compressor inlet	(m ³ /h)
Qa	the volume flow rate of suction gas before orifice	(m ³ /h)
VS	Gas specific volume at compressor inlet	(m ³ /kg)
VO	Gas specific volume before orifice	(m ³ /kg)

4.3.1 Acceptance Criteria

The volume rate flow of suction gas calculated from the actual values should be acceptable if it is over 95% of the standard volume flow rate of suction gas. The standard volume flow rate of suction gas is calculated by the approximate expression that has been developed based on the test results of numerous compressors over many years.

4.3.2 Records

The test results are recorded in Appendix-1: Screw Compressor Test Records.

[Break Horse Power]**4.4 Measuring Break Horse Power****4.4.1 Purpose**

Torque and motor revolutions are measured to calculate the break horse power.

4.4.2. Measurement Method/Equipment and Conditions

Measurement conditions are the same as for the capacity test.

Torque is measured using the torque meter mounted on the rotational axis.

Motor revolutions are measured using a tachometer.

4.4.3. Break horse power is calculated from the formula (3) below using the reading value of the torque meter.

$$\text{kW} = \frac{1}{1000} \times \frac{2\pi}{60} \times \text{RPM} \times \text{TRQ} \dots (3)$$

kW	break horse power	(kW)
RPM	motor revolution	(min ⁻¹)
TRQ	torque	(Nm)

4.4.4. Acceptance Criteria

If the break horse power from above is less than 105% of the standard power value, it should be acceptable. The standard power value is calculated by the approximate expression which has been developed based on the test results of numerous compressors for many years.

4.4.5. Records

The test results are recorded in Appendix-1: Screw Compressor Test Records.

5. Mechanical Running Test

5.1 Purpose

After compressor operation stabilizes*, perform a two hour running test to check for faults by measuring the surface temperature of the compressor.

*Stable operation state means the change of lubrication oil temperature is within 3 degrees in 30minutes while meeting the test conditions stipulated in paragraph 4.2 and Table-1, 30minutes after start-up.

5.2 Measurement Method/Equipment and Conditions

In 30minutes after start-up when the compressor operation reaches stable state while maintaining the test conditions stipulated in paragraph 4.2 and Table-1, measure the surface temperature at each point shown in Figure-2 and Figure-3 and check the lubrication, vibration, noise and for other abnormalities.

The surface temperature measurement locations are shown in Figures 2 and 3.

Figure 2: Single Stage Compressor

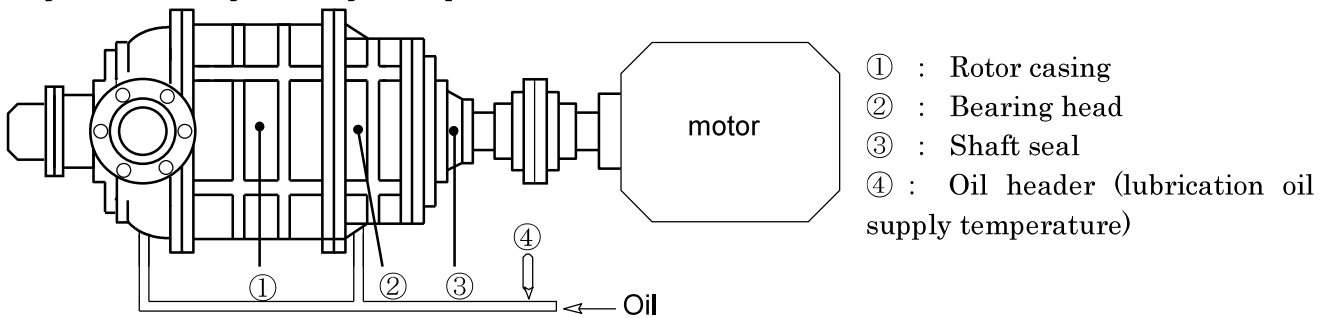
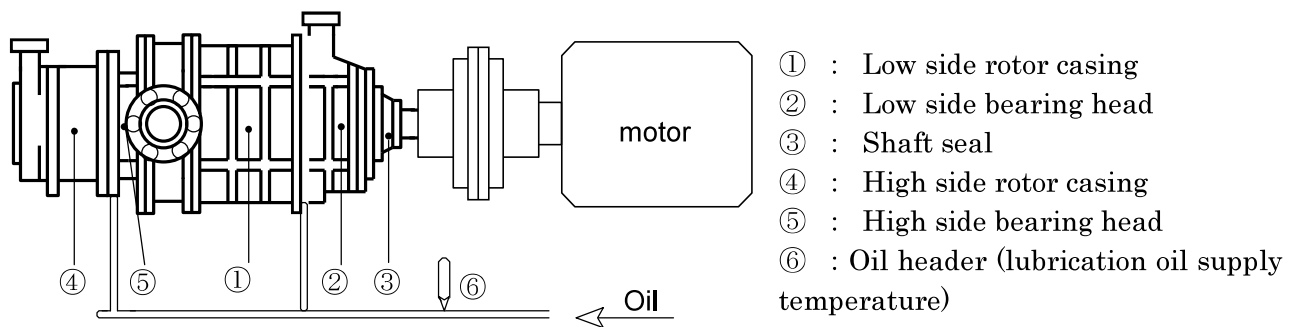

Figure 3: Compound Type Compressor



5.3 Acceptance Criteria

Measurement values that do not exceed the values indicated in Table-2 are accepted.

Single stage compressor	Compound type two stage compressor	Allowable value
① Rotor casing	① Low side rotor casing	Lubrication oil temperature +35°C
② Bearing head	② Low side bearing head	Lubrication oil temperature +35°C
③ Shaft seal	③ Shaft seal	Lubrication oil temperature +20°C
	④ High side rotor casing	Lubrication oil temperature +35°C
	⑤ High side bearing head	Lubrication oil temperature +35°C

Table 2 Surface Temperature Criteria

5.4 Records

The test results are recorded in Appendix 1: Screw Compressor Test Records.

6. Vibration and Noise Tests

6.1 Purpose

Noise and vibration tests are carried out during mechanical running test to check whether the compressor's noise and vibration are within the standard shipping values or not.

6.2 Measurement Method

6.2.1 Vibration

The amplitude of vibration is measured with a general purpose vibrometer (frequency analysis of the vibration is not performed.)

6.2.2 Measurement Method

Measurement points are shown in Figures 4 and Figure 5. Using a magnetic pickup, amplitudes are measured at each point (V, H, A for single stage compressors and VL, HL, AL, VH, HH, AH for compound type compressors).

6.2.3 Noise

Noise is measured using a sound level meter as specified in the standard JIS C 1509(2017) *Electroacoustics-Sound level meters-* in accordance with JIS B 8346 (1991) *Fans, blowers and compressors - Determination of A-weighted sound pressure level.* When the difference between the actual measurement and the background noise value is less than 10 dB, the actual measurement value should be corrected according to JIS Z 8731 (2019) *Acoustics -- Description and measurement of environmental noise.*

6.2.4 Measurement Method

Noise measurement points are shown as P-point in Figures 4 and 5.

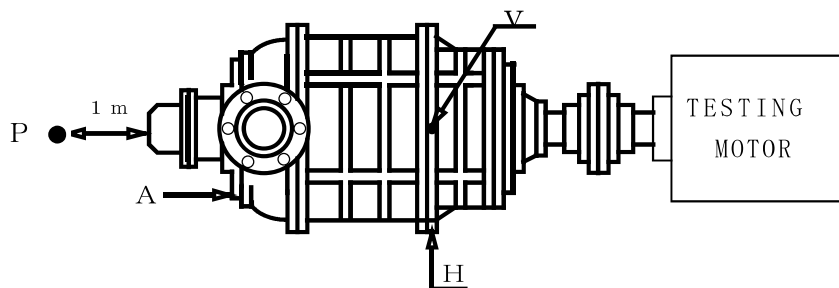

Figure 4
Single Stage Compressor

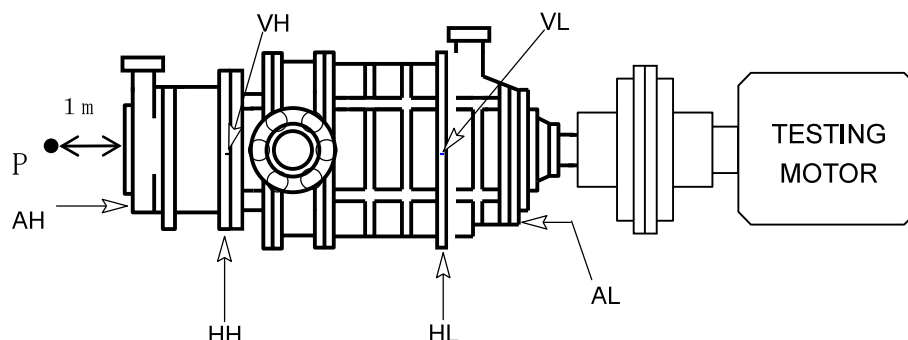

Figure 5
Compound Type Compressor

6.3 Acceptance Criteria

Compressors with results not exceeding the values shown in Table 1 *Noise and Vibration Shipment Standards for Screw Compressors* are accepted.

6.4 Records

The test results are recorded in Appendix-1: Screw Compressor Test Records.

Appendix Table 1

Noise and Vibration Shipment Standards for Screw Compressors

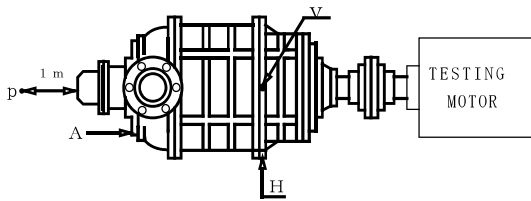

Single stage compressor

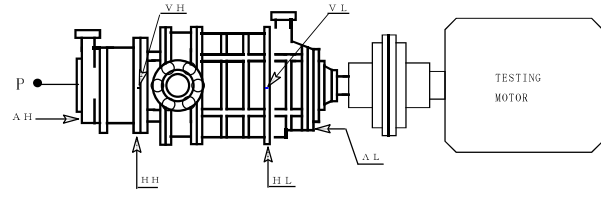

Compound type compressor

[Noise]

Compressor type	Discharge port	Acceptance value
1 2 5 SUD	L.M.H	8 4
1 2 5 LUD	L.M.H	8 4
1 6 0 SUD	L.M.H	8 4
1 6 0 MUD	L.M.H	8 4
1 6 0 LUD	L.M.H	8 5
2 0 0 SUD	L.M.H	8 6
2 0 0 MUD	L.M.H	8 7
2 0 0 LUD	L.M.H	8 8
2 5 0 SUD	L.M.H	8 8
2 5 0 MUD	L.M.H	9 0
2 5 0 LUD	L.M.H	9 0
3 2 0 SUD	L.M.H	9 5
3 2 0 MUD	L.M.H	9 7
3 2 0 LUD	L.M.H	9 8
3 2 0 L LUD	L.M.H	1 0 3
4 0 0 SUD	L.M.H	1 0 3
4 0 0 MUD	L.M.H	1 0 4
4 0 0 LUD	L.M.H	1 0 5
4 0 0 L LUD	L.M.H	1 0 6
4 0 0 X LUD	L.M.H	1 0 7
4 0 0 X X LUD	L.M.H	1 0 8
1610C	L.M.H	8 4
1612C	L.M.H	8 6
1612C 2poles Speed increasing	L.M.H	9 0
1612C 4poles Speed increasing	L.M.H	8 8
2 0 1 6 C	L.M.H	8 7
2 5 2 0 C	L.M.H	9 2
3 2 2 5 C	L.M.H	9 8
4 0 2 5 C	L.M.H	1 0 5
4 0 3 2 C	L.M.H	1 0 8
1 7 0 JS	L.M.H	8 1
1 7 0 JM	L.M.H	8 4
1 7 0 JL	L.M.H	8 6
2 2 0 JS	L.M.H	8 6
2 2 0 JM	L.M.H	8 6
2 2 0 JL	L.M.H	8 9
2 8 0 JS	L.M.H	8 8
2 8 0 JM	L.M.H	9 0
2 8 0 JL	L.M.H	9 2

Compressor type	Discharge port	Acceptance value
1 6 0 VSD	L.M.H	8 4
1 6 0 VMD	L.M.H	8 4
1 6 0 VLD	L.M.H	8 5
2 0 0 VSD	L.M.H	8 6
2 0 0 VMD	L.M.H	8 7
2 0 0 VLD	L.M.H	8 8
2 5 0 VSD	L.M.H	8 8
2 5 0 VMD	L.M.H	9 0
2 5 0 VLD	L.M.H	9 0
2 5 0 V L L D	L.M.H	9 2
3 2 0 VSD	L.M.H	9 5
3 2 0 VMD	L.M.H	9 7
3 2 0 VLD	L.M.H	9 8
4 0 0 VSD	L.M.H	1 0 3
4 0 0 VMD	L.M.H	1 0 4
1 6 0 VSR	L.M.H	8 7
1 6 0 VLR	L.M.H	8 8
2 0 0 VSR	L.M.H	8 9
2 0 0 VLR	L.M.H	9 1
2 5 0 VSR	L.M.H	9 1
2 5 0 VLR	L.M.H	9 3

Vibration

(Frequency range: 10 - 1000 Hz) (half amplitude peak value)
 Values in gray column are reference values as per API619

Type	Measurement points	Allowance value for amplitude μm (half amplitude peak value)	allowance value for velocity mm/s (RMS)
Single stage Compressors	V	2 0	8
	H	2 0	8
	A	2 0	8
Compound type two stage compressors	VH	2 0	8
	HH	2 0	8
	AH	2 0	8
	VL	2 0	8
	HL	2 0	8
	AL	2 0	8

* This criteria is acceptable for the downward discharge type compressors.

Appendix Table 2

Measurement Equipment List

*This list is only for reference. Actual instruments differ depending on test benches.

Name	Use place	Registration No.	Type	Term of validity
U tube manometer	Pressure Before Orifice	AA11007	PM12-231 (0~14.6kPa)	May, 2014
	Suction Pressure	AA11008	PM12-231 (0~14.6kPa)	May, 2014
	Differential Pressure Across Orifice	AA11009	PM12-231 (0~14.6kPa)	May, 2014
Bourdon tube pressure gauge	Discharge Pressure	AA21001	DU3/8 x 150mm x 2.0MPa	Aug., 2011
	Oil Pressure	AA21002	DU1/2 x 50mm x 2.0MPa	Aug., 2011
Aneroid atmospheric meter	Atmospheric Pressure	AA-AK002	930~1070hPa	March, 2012
Strain gauge type torque meter	Running Torque	AATQ008	TMNR-5KNM	Aug., 2011
Rotating meter		AAPR003	HT-4200	Oct., 2011
Bar type thermometer	Suction Temperature	On48	Alcohol temperature gauge	Jan., 2012
	Discharge Temperature	On50		Jan., 2012
	Temperature Before Orifice	On70		Jan., 2012
	Oil Temperature	On54		Jan., 2012
Noise meter		AA-SN004	NL-26	March, 2014
Vibration meter		AA-SD004	VM-83	July, 2013
Bar type thermometer	Rotor casing	On17	Alcohol temperature gauge	Jan., 2012
	Bearing head	On67		Jan., 2012
	Shaft seal	On51		Jan., 2012
Motors		No.7	6300V x 2100KW x 2P x 4000rpm	

Instruments above are regularly calibrated according to the company rules.

SAMPLE

[Appendix 1 : Screw Compressor Test Records 1/3]

MYCOM

Report No. 0

Screw Compressor Test Record

Item No.	:	-
Date	:	January 0, 1900
Model	:	0
Serial No.	:	
Test fluid	:	IR
Orifice No.	:	0
Time	:	0:00
Inspection items	:	Int...

SURVEYOR

Sample

Revolution		0	min ⁻¹
Running Torque		0.0	N·m
Room Temperature		0.0	℃
Atmospheric Pressure		0	hPa.
Discharge Pressure		0.00	MPa.G
Suction Pressure	L(0.00) kPa	0.00	kPa
	R(0.00) kPa		
Pressure Before Orifice	L(0.00) kPa	0.00	kPa
	R(0.00) kPa		
Pressure Difference at Orifice	L(0.00) kPa	0.00	kPa
	R(0.00) kPa		
Oil Pressure		0.00	MPa.G
Suction Temperature		0.0	℃
Temperature Before Orifice		0.0	℃
Oil Temperature		0.0	℃
Discharge Temperature		0.0	℃

Noise		0.0	dB(A)
Background Noise		0.0	dB(A)

TEST RESULTS;

Temp. of Rotor Casing		0.0	℃
Temp. of Bearing Head		0.0	℃
Temp. of Shaft Seal		0.0	℃
Test of Vibration	V	0	μm
	H	0	μm
	A	0	μm

Approved by : _____

Checked by : _____



Report No. 0

Screw Compressor Test Results

SURVEYOR

Sample

GENERAL INFORMATION;

Item No. : -
 Model : 0
 Serial No. : 0
 Date of Test : January 0, 1900
 Tested at : MAYEKAWA MFG. CO.,LTD. MORIYA PLANT
 2000, Tatsuzawa Moriya-City, Ibaraki-Pref., 302-0118, Japan

PERFORMANCE TEST ;

	STANDARD	ACTUAL	Judgment	CRITERIA
Capacity (m ³ /h) :	1.0	2.0 (200.0 %)	Accepted	95% and more
Brake Kilowatts (BkW) :	3.0	4.0 (133.3 %)	Accepted	105% or less

MECHANICAL RUNNING TEST ;

	ALLOWABLE MAXIMUM	ACTUAL	Judgment
Temp. of Rotor Casing :	35.0 °C	0.0 °C	Accepted
Temp. of Bearing Head :	35.0 °C	0.0 °C	Accepted
Temp. of Shaft Seal :	20.0 °C	0.0 °C	Accepted

VIBRATION AND NOISE TESTS ;

	ALLOWABLE MAXIMUM	ACTUAL	Judgment
Noise :	92 dB(A)	0.0 dB(A)	Accepted
Vibration (Frequency range : 10 - 1000Hz)			
V : 20 μm	20 μm	0 μm	Accepted
H : 20 μm	20 μm	0 μm	Accepted
A : 20 μm	20 μm	0 μm	Accepted

Approved by : _____

Checked by : _____

Appearance and Dimensional Test

1. Scope

This procedure applies to the appearance and dimensional test after mounting an indicator prior to painting.

2. Appearance and Dimensional Test

Based on an external inspection of the compressor dimensions, there must be no defects in the appearance and the compressor appearance must conform to the customer's authorized drawing.

Based on the customer's authorized drawing, measure each dimension and record them on the Screw Compressor Outer Dimensions report.

The following dimensions are measured:

<Single stage compressor>

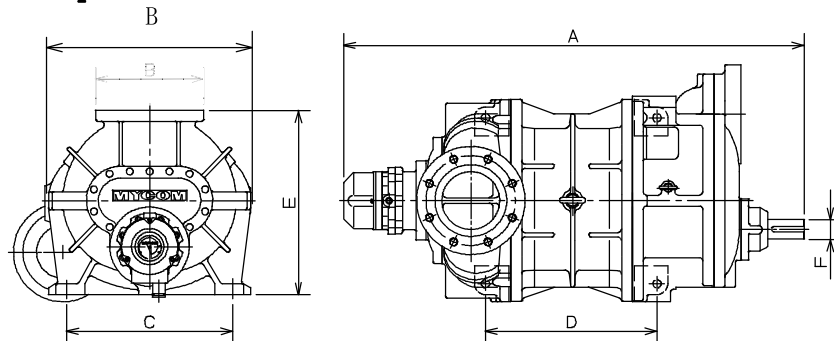

<Compound type two-stage compressor>

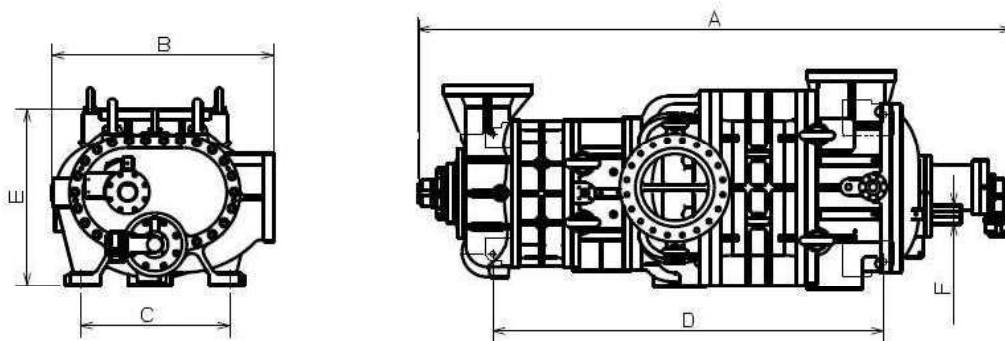

3. Acceptance Criteria

There must be no defects in appearance and the compressor appearance must conform to the customer's authorized drawing.

The compressor must meet the dimensional tolerance defined in the Screw Compressor Outer Dimensions report.

4. Records

The test results are recorded on the Screw Compressor Outer Dimensions report.

SAMPLE

Screw compressor outer dimensions report

MYCOM

Outer dimensions report

* General information ;

Item No. : _____
 Report No. : _____
 Type of compressor : Screw compressor
 Model : _____
 Serial No. : _____
 Inspection date : _____
 Inspection items : _____
 Plant location : MAYEKAWA MFG. CO.,LTD.
 MORIYA PLANT
 2000, Tatsuzawa Moriya-city,
 Ibaraki-pref., 302-0118, Japan

SURVEYOR

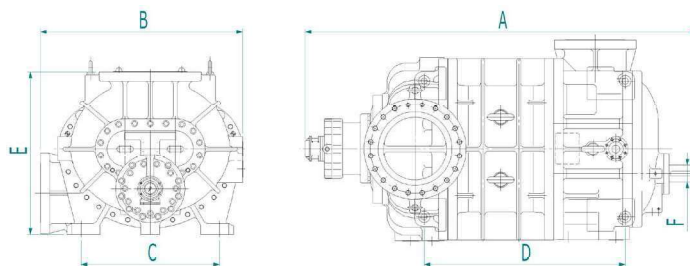

	Standard		Actual	Result
A	2613.0	±11.0		
B	1290.0	±8.0		
C	880.0	±2.5		
D	1401.0	±2.5		
E	1050.0	±8.0		
F	110.0	±0.011		

Judgment : Accepted

Approved by : _____

Checked by : _____

MAYEKAWA MFG,CO.,LTD. MoriyaPlant

Screw Compressor Standard Inspection Procedures
Document No. SCSD-017-04
Painting Check

Moriya plant, Mayekawa Mfg. Co., Ltd.

05	2020/10/06	T.Sakguchi	Kato	Koizumi	Review and revised
04	2015/6/1	Suzukawa	Sasaki	Kawasaki	Review and revised
03	2014/11/25	Suzukawa	Sasaki	Kawasaki	Review and revised
02	2014/07/30	Suzukawa	Sasaki	Kawasaki	Review and revised
01	2003/08/21	K.NISHIYAMA	T.SAKA	A.KOIZUMI	REVIEW
00	2000/03/21	TAKAHASHI	KOYANAGI	KOIZUMI	Original
Revision	Date	Created by	confirmed by	Approved by	Description

PAINTING CHECK**1. Scope**

This specification shall be applied for the MYCOM bare shaft compressor.

2. Painting System**2.1 Surface Preparation**

The surface shall be clean up by applying warm water of 55-60 degC(131-140 degF), after assembly of the compressor.

2.2 Primer Coat

Brand Name of the Material	: Rock Hold (epoxy-based)
Manufacturer	: Rock Paint Co.
Reference Color Code/No.	: 051-9500 IB-1852 N-5
Painting Mode	: Spray
Number of Coat	: 1
Dry Film Thickness	: 20 thru 40 μm

2.3 Top Finish Coat

Brand Name of the Material	: Hi Rock DX (urethane-based)
Manufacturer	: Rock Paint Co.
Reference Color Code/No.	: 073-9080 IB-1858 N-7
Painting Mode	: Spray
Number of Coat	: 1
Dry Film Thickness	: 30 thru 50 μm

3. Painting Process

The painting work should be done after assembly of the compressor. The painting process should be as follows:

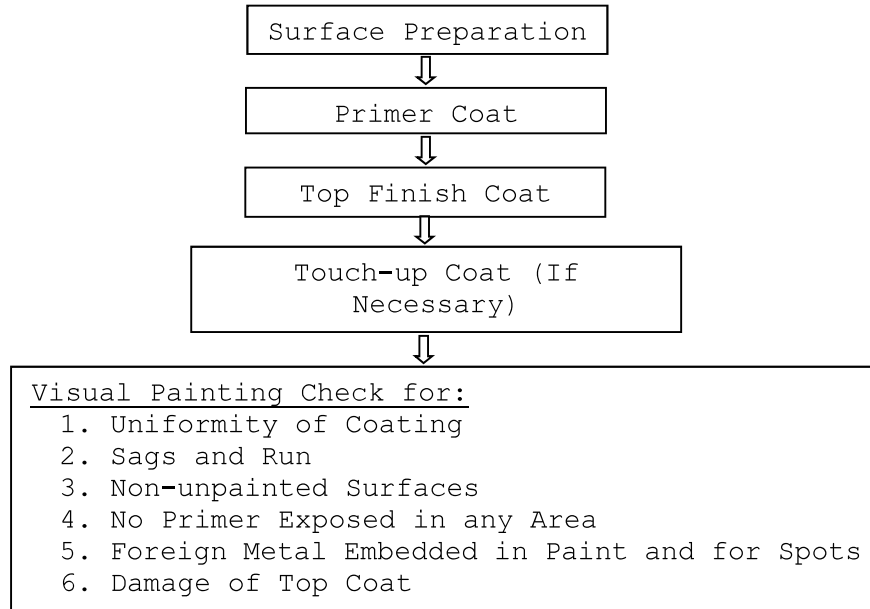

The time difference between each process is a minimum of 12 hours.

4. Quality control and Other Instructions

Careful attention shall be taken for the following items.

4.1 Surface

Each coat of paint shall be in a proper state of cure or dryness before application of the next coat.

4.2 Items Not Painted

The listed items below are not painted:

- a. Rotor shaft
- b. Compressor nametag plate
- c. Capacity indicator
- d. Other if specified

4.3 Dry Film Thickness (μm)

The dry film thickness shall be measured at 3 points for each coat by an electro-magnetic thickness gauge. The measurement results are recorded on the DRY FILM THICKNESS MEASUREMENT REPORT.

Dry Film Thickness Measurement Report Sample

MYCOM

Report No. 0

DRY FILM THICKNESS MEASUREMENT REPORT

Item No.	-
Type of Compressor	Screw Compressor
Compressor Model No.	0
Compressor Serial No.	0

1. PRIMER COAT:

DATE	COLOR	DRY THICKNESS (μm) (40 ~ 60 μm)			VISUAL CHECK
		A	B	C	
March 12, 2012	M PRIMER BROWN	54	52	56	Accepted

2. TOP FINISH COAT:

DATE	COLOR	DRY THICKNESS (μm) (40 ~ 60 μm)			VISUAL CHECK
		A	B	C	
March 12, 2012	N-7	54	56	59	Accepted

Measuring instrument: Electro-magnetic gauge
Model: SDM-pico/SANKHO

SURVEYOR

Checked by : _____

Approved by : _____

MAVEKAWA MFG. CO., LTD. Moriya Plant

SHIPMENT CHECK

1. Confirmation of Opening Protection:

-Any openings to the atmosphere shall be sealed with a gasket and blind flange

YES NO

-All drain, threaded connections and vent valves to be plugged.

2. Confirmation of Name Tag. Plate:

-Model Number and Serial Number to be correct as per order

Model No.:

Serial No.:

3. Confirmation of Rust Prevention:

-Compressor shaft surface to be protected with anti-corrosive coating

4. Confirmation of Pressurizing:

-Compressor to be pressurized with 0.15MPa of dry nitrogen against entry of air

5. Confirmation of Special Tool Box:

-Make sure the tool box selected is proper tool box for the particular compressor model

6. Confirmation of Crating:

-Compressor to be wrapped with plastic sheets for protection from water

-Compressor to be fastened to base of wooden crate and the crate to be checked for damage

7. Confirmation of shipping Markings

-Packing Number: C/S

-Ship To: _____

-MYCOM Standard Shipping Mark:



Checked By : _____ Date : _____