





	Gachsaran Polymer Industries Company HDPE Plant		
	Instrument Datasheet & Catalogs for Refrigerator Package	 	
PO No.: GPIC-PT-MA-PO-000-3029	Document Number: VD-GPIC-MA-3029-3029-0038	Rev. 02	Page 1 of 29

Instrument Datasheet & Catalogs for Refrigerator Package

Code1	<input type="checkbox"/> No Comment/ Approved (Applicable Only for "FOR REVIEW" and "For Approval" Documents) No comment and the document are released for Manufacturing.
Code2	<input checked="" type="checkbox"/> No Comment/ Approved with Note(s) Vendor/Sub-Contractor shall correct, revise and resubmit the document. The document is released for Manufacturing if changes incorporated.
Code3	<input type="checkbox"/> Commented Vendor/Sub-Contractor shall correct, revise and resubmit the document by the date specified. The document shall be revised under the Status of "R: Revised Issue". All corrected documents shall be resubmitted before starting the Manufacturing Process.
Code 4	<input type="checkbox"/> Not Accepted (Rejected) Vendor/Sub-Contractor shall re-work / re-design / re-specify the contents of the document according to the comments / reasons for rejection. All corrected documents shall be resubmitted before starting the manufacturing. Vendor/Sub-Contractor shall not proceed with subsequent works of Material Supply or Manufacturing until receiving Code1/Code2 or No Code from PURCHASER. Vendor/Sub-Contractor shall resubmit the document with the same revision within 6 working days after receiving comments.
No code	<input type="checkbox"/> No Code (Applicable Only for "For Information" Documents and "As Built DWGs") Document has been submitted for PURCHASER's Information (FI). Consistency, completeness and correctness of document content is in Vendor/Sub-Contractor's responsibility.
Above checking results by EIED shall in no way relieve Vendor of any liability, obligation and responsibility out of the purchase order and the mutual agreement in writing.	
 EIED Energy Industries Engineering & Design co.	Date: Feb. 23, 2026 Dept.: MA Signature: F.Hamooni

02	12-Feb-26	IFR	N.B	F.T	A.M
01	9-Dec-25	IFR	N.B	F.T	A.M
00	12-Oct-25	IFR	N.B	F.T	A.M
Rev.	DATE	PURPOSE OF ISSUE	PREPARED	CHECKED	APPROVED

				PRESSURE TRANSMITTER CONTROL DEVICES				Document No:	VD-GPIC-MA-3029-3029-0038		
								Document Title:	Instrument Data sheet & Catalogs		
				NO.	BY	APP	DATE	P.O.I.			
CLIENT: Gachsaran Polymer Industries Company (GPIC) P.O. NO.: GPIC-PT-MA-PO-000-3029 SERVICE: PROPYLENE REFERIGERATION PACKAGE				00	N.B	A.M	12.10.25	IFR			
				01	N.B	A.M	09.12.25	IFR			
				02	N.B	A.M	12.02.26	IFR			
GENERAL				1	Tag No.	SEE TABLE BELOW			Service: See Table Below		
				2	Qty						
				3	Function	Record <input type="checkbox"/>	Indicate <input checked="" type="checkbox"/>	Control <input checked="" type="checkbox"/>	VIA MCS Blind <input type="checkbox"/>	Trans <input checked="" type="checkbox"/> Other	
				4	Case	Mfr. Std. <input checked="" type="checkbox"/>	Nom. Size	Color:	<input type="checkbox"/> Other NOTE 2		
				5	Mounting	Flush <input type="checkbox"/>	Surface <input type="checkbox"/>	Yoke <input checked="" type="checkbox"/>	Other		
				6	Enclosure Class	Gen. Purpose <input type="checkbox"/>	Weather Proof <input type="checkbox"/>	Explosion Proof <input type="checkbox"/>			
				7	Power Supply	117V 60 Hz <input type="checkbox"/>	Other ac <input type="checkbox"/>	DC <input checked="" type="checkbox"/>	Volts 24 V		
				8	Chart	N/A	Strip <input type="checkbox"/>	Roll <input type="checkbox"/>	Fold <input type="checkbox"/>	Circular <input type="checkbox"/>	Time Mark: <input type="checkbox"/>
				9	Chart Drive	N/A	Speed	Number	Power		
				10	Scales	Type: LCD / DIGITAL (UNITS per NOTE 15)					
						Range: SEE TABLE BELOW					
XMTR				11	Transmitter Output	4-20 mA <input checked="" type="checkbox"/> NOTE 9	10-50mA <input type="checkbox"/>	21-103 kPa (3-15 psig) <input type="checkbox"/>	Other		
						For Receiver, see spec sheet. WIRED TO UCP VIA JUNCTION BOXES (2 WIRE OUTPUT) NOTE 9					
CONTROLLER VIA UCP				12	Control Modes	P = Prop (Gain), 1-Integral (Auto Reset), D = Derivative (Rate)					
						Sub: s = slow, f = fast, If <input type="checkbox"/> Df <input type="checkbox"/> P <input checked="" type="checkbox"/> PID <input type="checkbox"/> PD <input type="checkbox"/> PI <input type="checkbox"/> Is <input type="checkbox"/> Ds <input type="checkbox"/>					
						Other					
				14	Action	On Measurement Increase, Output:			Increases <input type="checkbox"/> Decreases <input type="checkbox"/>		
				15	Auto-Man Switch	None <input type="checkbox"/>	MFR Std <input type="checkbox"/>	Other <input checked="" type="checkbox"/>	NOTE 21		
				16	Set Point Adj.	Manual <input type="checkbox"/>	External <input type="checkbox"/>	Remote <input checked="" type="checkbox"/> UCP	Other NOTE 9		
				17	Manual Reg.	None <input type="checkbox"/>	MFR Std <input type="checkbox"/>	Other			
				18	Output	4-20 mA <input type="checkbox"/> NOTE 9	10-50 mA <input type="checkbox"/>	21-103 kPa (3-15 psig) <input type="checkbox"/>	Other		
ELEMENT				19	Service	Gage Press <input checked="" type="checkbox"/>	Vacuum <input type="checkbox"/>	Absolute <input type="checkbox"/>	Compound <input type="checkbox"/>		
				20	Element Type	Diaphragm <input type="checkbox"/>	Helix <input type="checkbox"/>	Bourdon <input type="checkbox"/>	Bellows <input type="checkbox"/>	Other NOTE 19	
				21	Material (body)	316SS <input checked="" type="checkbox"/>	Ber Copper <input type="checkbox"/>	Other <input type="checkbox"/>			
				22	Range	Fixed <input type="checkbox"/>	Adj. Range <input checked="" type="checkbox"/>				
						Overrange Protection to: SEE TABLE BELOW					
				23	Process Data	Press.: Nor.: SEE TABLE BELOW	MAX.:	Element Range:			
				24	Process Conn.	1/4" in NPT <input type="checkbox"/>	1/2" in NPT (F) <input checked="" type="checkbox"/>	Other: 1/2" CONDUIT CONNECTION			
						Location: Bottom: <input checked="" type="checkbox"/>	Back <input type="checkbox"/>	Other			
VIA UCP				25	Alarm Switches	Quantity: BY UCP REFER TO SETPOINT LIST	Form	Rating			
				26	Function	Press. <input checked="" type="checkbox"/>	Deviation <input type="checkbox"/>	Contacts	On Icr. Meas.		
OPTIONS				27	Options	Filter Reg. <input type="checkbox"/>	Sup. Gage <input type="checkbox"/>	Output Gage <input type="checkbox"/>	Charts		
						Diaphragm Seal <input type="checkbox"/>	Type N/A	Diaphragm	Bot. Bowl		
						Conn. Capillary: N/A	Length	Mtl.			
						Other: ELECTRICAL GROUND SCREW REQUIRED					
AREA CLASSIFICATION						IEC <input checked="" type="checkbox"/> ZONE 2, EExia IIB-T3	IP-65 / NEMA4X	Agency Approval: ATEX			
Item	Qty	Tag No.	Pressure PSIG - BarG		Operating Press. PSIG / BarG		Calibration mA PSIG / BarG		Manufacturer/ (Note 16)	Service	
			Range	Over	Min	Max	4	20	Model no.		
A	1	PT-61111	-14.7 to 290	580	22.5	25.9	0.00	250		PROPYLENE & SYNTHETIC OIL SIL2 CERTIFIED	
		SUCTION	-1.01 to 20.0	40.0	1.55	1.76	0.0	17.2			
B	1	PT-61113	-14.7 to 580	1160	304.6	343.3	0.00	580		PROPYLENE & SYNTHETIC OIL	
		OIL SUPPLY	-1.01 to 40.0	80.0	21.0	23.7	0.0	40.0			
C											
D											
AA	1	PT-61121	-14.7 to 290	580	22.5	25.9	0.00	250		PROPYLENE & SYNTHETIC OIL SIL2 CERTIFIED	
		SUCTION	-1.01 to 20.0	40.0	1.55	1.76	0.0	17.2			
BB	1	PT-61123	-14.7 to 580	1160	304.6	256.1	0.00	580		PROPYLENE & SYNTHETIC OIL	
		OIL SUPPLY	-1.01 to 40.0	80.0	21.0	17.7	0.0	40.0			
CC	1										
DD	1	PT-61141	-14.7 to 580	1160	85.5	289.1	0.00	580		PROPYLENE & SYNTHETIC OIL	
		ECONOMIZER	-1.01 to 40.0	80.0	5.90	19.9	0.0	40.0			

	PRESSURE TRANSMITTER CONTROL DEVICES				Document No:	VD-GPIC-MA-3029-3029-0038
					Document Title:	Instrument Data sheet & Catalogs
CLIENT: Gachsaran Polymer Industries Company (GPIC) P.O. NO.: GPIC-PT-MA-PO-000-3029 SERVICE: PROPYLENE REFERIGERATION PACKAGE	NO.	BY	APP	DATE	P.O.I.	
	00	N.B	A.M	12.10.25	IFR	
	01	N.B	A.M	09.12.25	IFR	
	02	N.B	A.M	12.02.26	IFR	

Notes:

- 1 SYSTEM DESIGN PRESSURE & TEMPERATURE:

FV to 362.5 PSIG	25.0 BarG	@	250 °F	121 °C	FOR ITEMS: 1, 2
			-45 °F	-43 °C	
FV to 406 PSIG	28.0 BarG	@	250 °F	121 °C	FOR ITEMS: 3
			-20 °F	-29 °C	
- 2 TRANSMITTER ELECTRICAL HOUSING MUST BE POLYURETHANE COVERED ALUMINUM
- 3 REFERENCE ACCURACY: +/- 0.1 % OF FULL SCALE & +/- 0.15 % GUARRANTEED STABILITY OVER FIVE YEARS
- 4 INSTRUMENT SHALL BE SUITABLE FOR MARINE, SALT LADEN, CORROSIVE ENVIRONMENT
- 5 CALIBRATION CERTIFICATE REQUIRED NOT REQUIRED
- 6 HARD COPY OF IEC-79, EExia IIB-T5 CERTIFICATE REQUIRED NOT REQUIRED PER IEC 60079
- 7 CUSTOMER SPECIFICATION: N/A, N/A & N/A
- 8 ELECTRICAL CLASS CERTIFICATION SHALL BE SHOWN ON ALUMINUM DIE-CASTING HOUSING STAMPED USING STAINLESS STEEL TAG PERMANENTLY ATTACHED TO THE DEVICE
- 9 HART COMMUNICATION SHALL BE SUITABLE OVER RANGE OF APPLICATION
- 10 AUSTENSIC 316 SS BOLTS REQUIRED
- 12 MOUNTING BRACKET FOR 2-IN PIPE BY VENDOR (AGCO)
- 13 LCD METER WITH POLYURETHANE COVERED ALUMINUM COVER REQUIRED
- 14 ALL DOCUMENTS TO BE SUBMITTED IN BOTH HARD AND ELECTRONIC FORMAT
- 15 INDICATOR TO SHOW BARG
- 16 MATERIAL SHALL BE PER APPROVED VENDOR LIST. MANUFACTURER LISTED ABOVE IS FOR REFERENCE.
- 17 ELECTRICAL CONNECTION: M20 1/2" NPT
- 18 REQUIRED ASSEMBLY AS PER BELOW PICTURE WITH 2-WAY MANIFOLD OR ISOLATION VALVE
- 19 TRANSMITTERS ARE SUPPLIED WITH THIN FILM TYPE PIEZORESISTIVE SENSORS
- 20 SENSOR FILLING: PAG SYNTHETIC OIL
- 21 REFER TO CONTROL NARRATIVE AND SET POINT LIST FOR THE CONTROLLER ACTION
- 22 HOUSING SHALL BE SELECTED TO SHOW TRANSMITTER LCD AT 90 DEGREE FROM INLET AS SHOWN BELOW.
- 23=REFER TO P&ID AND VALVE DATA SHEETS FOR 2-WAY MANIFOLD VALVE INFORMATION.

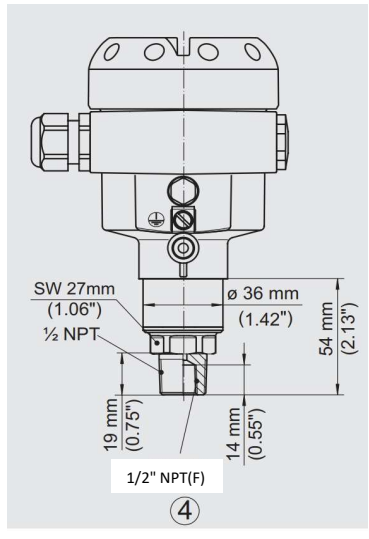

				PRESSURE TRANSMITTER INDICATOR DEVICES				Document No:	VD-GPIC-MA-3029-3029-0038				
								Document Title:	Instrument Data sheet & Catalogs				
				NO.	BY	APP	DATE	P.O.I.					
CLIENT: Gachsaran Polymer Industries Company (GPIC) P.O. NO.: GPIC-PT-MA-PO-000-3029 SERVICE: PROPYLENE REFERIGERATION PACKAGE				00	N.B	A.M	12.10.25	IFR					
				01	N.B	A.M	09.12.25	IFR					
				02	N.B	A.M	12.02.26	IFR					
GENERAL				1	Tag No.	SEE TABLE BELOW Service: See Table Below							
				2	Qty								
				3	Function	Record <input type="checkbox"/>	Indicate <input checked="" type="checkbox"/>	Control <input type="checkbox"/>	VIA MCS <input type="checkbox"/>	Blind <input type="checkbox"/>	Trans <input checked="" type="checkbox"/>	Other <input type="checkbox"/>	
				4	Case	Mfr. Std. <input checked="" type="checkbox"/>	Norm. Size <input type="checkbox"/>	Color: <input type="checkbox"/>	Other <input type="checkbox"/>	NOTE 2			
				5	Mounting	Flush <input type="checkbox"/>	Surface <input type="checkbox"/>	Yoke <input checked="" type="checkbox"/>	Other <input type="checkbox"/>				
				6	Enclosure Class	Gen. Purpose <input type="checkbox"/>	Weather Proof <input type="checkbox"/>	Explosion Proof <input type="checkbox"/>					
				7	Power Supply	117V 60 Hz <input type="checkbox"/>	Other ac <input type="checkbox"/>	DC <input checked="" type="checkbox"/>	Volts 24 V				
				8	Chart	N/A	Strip <input type="checkbox"/>	Roll <input type="checkbox"/>	Fold <input type="checkbox"/>	Circular <input type="checkbox"/>	Time Mark: <input type="checkbox"/>		
				9	Chart Drive	N/A	Speed						
				10	Scales	Type: LCD / DIGITAL (UNITS per NOTE 15)							
						Range: SEE TABLE BELOW							
XMTR				11	Transmitter Output	4-20 mA <input checked="" type="checkbox"/>	NOTE 9	10-50mA <input type="checkbox"/>	21-103 kPa (3-15 psig) <input type="checkbox"/>	Other <input type="checkbox"/>			
						For Receiver, see spec sheet. WIRED TO UCP VIA JUNCTION BOXES (2 WIRE OUTPUT) NOTE 9							
CONTROLLER VIA UCP				12	Control Modes	P = Prop (Gain), I-Integral (Auto Reset), D = Derivative (Rate)							
						Sub: s = slow, f = fast, if <input type="checkbox"/> Df <input type="checkbox"/> P <input type="checkbox"/> PID <input type="checkbox"/> PD <input type="checkbox"/> PI <input type="checkbox"/> Is <input type="checkbox"/> Ds <input type="checkbox"/>							
						Other <input type="checkbox"/>							
				14	Action	On Measurement Increase, Output: Increases <input type="checkbox"/> Decreases <input type="checkbox"/>							
				15	Auto-Man Switch	None <input type="checkbox"/>	MFR Std <input type="checkbox"/>	Other <input checked="" type="checkbox"/>				NOTE 21	
				16	Set Point Adj.	Manual <input type="checkbox"/>	External <input type="checkbox"/>	Remote <input checked="" type="checkbox"/>	UCP			Other <input type="checkbox"/>	NOTE 9
				17	Manual Reg.	None <input type="checkbox"/>	MFR Std <input type="checkbox"/>	Other <input type="checkbox"/>					
				18	Output	4-20 mA <input type="checkbox"/>	NOTE 9	10-50 mA <input type="checkbox"/>	21-103 kPa (3-15 psig) <input type="checkbox"/>	Other <input type="checkbox"/>			
ELEMENT				19	Service	Gage Press <input checked="" type="checkbox"/>	Vacuum <input type="checkbox"/>	Absolute <input type="checkbox"/>		Compound <input type="checkbox"/>			
				20	Element Type	Diaphragm <input type="checkbox"/>	Helix <input type="checkbox"/>	Bourdon <input type="checkbox"/>	Bellovs <input type="checkbox"/>	Other <input type="checkbox"/>			NOTE 19
				21	Material (body)	316SS <input checked="" type="checkbox"/>	Ber Copper <input type="checkbox"/>	Other <input type="checkbox"/>					
				22	Range	Fixed <input type="checkbox"/>	Adj. Range <input checked="" type="checkbox"/>						
						Overrange Protection to: SEE TABLE BELOW							
				23	Process Data	Press.: Nor.: SEE TABLE BELOW	MAX.:	Element Range:					
				24	Process Conn.	1/4" in NPT <input type="checkbox"/>	1/2" in NPT (F) <input checked="" type="checkbox"/>	Other: 1/2" CONDUIT CONNECTION					
						Location: Bottom: <input checked="" type="checkbox"/> Back <input type="checkbox"/> Other <input type="checkbox"/>							
VIA UCP				25	Alarm Switches	Quantity: BY UCP REFER TO SETPOINT LIST Form Rating							
				26	Function	Press. <input checked="" type="checkbox"/>	Deviation <input type="checkbox"/>	Contacts <input type="checkbox"/>	On Icr. Meas.				
OPTIONS				27	Options	Filter Reg. <input type="checkbox"/>	Sup. Gage <input type="checkbox"/>	Output Gage <input type="checkbox"/>	Charts				
						Diaphragm Seal <input type="checkbox"/>	Type N/A	Diaphragm <input type="checkbox"/>	Bot. Bowl				
						Conn. <input type="checkbox"/>	Capillary: N/A	Length <input type="checkbox"/>	Mtl.				
						Other: ELECTRICAL GROUND SCREW REQUIRED							
AREA CLASSIFICATION						IEC <input checked="" type="checkbox"/>	ZONE 2, EExia IIB-T3 IP-65 / NEMA4X	Agency Approval: ATEX					

Item	Qty	Tag No.	Pressure PSIG - BarG		Operating Press. PSIG / BarG		Calibration mA PSIG / BarG		Manufacturer/ (Note 16) Model no.	Service
			Range	Over	Min	Max	4	20		
A	1	PT-61131	-14.7 to 580	1160	275.6	303.1	0.00	580		PROPYLENE &
		SEPARATOR	-1.01 to 40.0	80.0	19.0	20.6	0.0	40.0		SYNTHETIC OIL
B	1	PT-61132	-14.7 to 580	1160	275.6	303.1	0.00	580		PROPYLENE &
		COALESCER	-1.01 to 40.0	80.0	19.0	20.9	0.0	40.0		SYNTHETIC OIL
C	1	PT-61133	-14.7 to 580	1160	329.0	361.8	0.00	580		PROPYLENE &
		OIL FILTER	-1.01 to 40.0	80.0	22.7	25.0	0.0	40.0		SYNTHETIC OIL
D	1	PT-61134	-14.7 to 580	1160	290.1	319.1	0.00	580		PROPYLENE &
		OIL FILTER	-1.01 to 40.0	80.0	20.0	22.0	0.0	40.0		SYNTHETIC OIL

	PRESSURE TRANSMITTER INDICATOR DEVICES				Document No:	VD-GPIC-MA-3029-3029-0038
					Document Title:	Instrument Data sheet & Catalogs
CLIENT: Gachsaran Polymer Industries Company (GPIC) P.O. NO.: GPIC-PT-MA-PO-000-3029 SERVICE: PROPYLENE REFERIGERATION PACKAGE	NO.	BY	APP	DATE	P.O.I.	
	00	N.B	A.M	12.10.25	IFR	
	01	N.B	A.M	09.12.25	IFR	
	02	N.B	A.M	12.02.26	IFR	

- Notes:
- SYSTEM DESIGN PRESSURE & TEMPERATURE:

FV to 362.5 PSIG	25.0 BarG	@	250 °F	121 °C	FOR ITEMS: 1, 2
			-45 °F	-43 °C	
FV to 406 PSIG	28.0 BarG	@	250 °F	121 °C	FOR ITEMS: 3
			-20 °F	-29 °C	
 - TRANSMITTER ELECTRICAL HOUSING MUST BE POLYURETHANE COVERED ALUMINUM
 - REFERENCE ACCURACY: ± 0.1 % OF FULL SCALE & ± 0.15 % GUARRANTEED STABILITY OVER FIVE YEARS
 - INSTRUMENT SHALL BE SUITABLE FOR MARINE, SALT LADEN, CORROSIVE ENVIRONMENT
 - CALIBRATION CERTIFICATE REQUIRED NOT REQUIRED
 - HARD COPY OF IEC-79, EExia IIB-T5 CERTIFICATE REQUIRED NOT REQUIRED PER IEC 60079
 - CUSTOMER SPECIFICATION: N/A, N/A & N/A
 - ELECTRICAL CLASS CERTIFICATION SHALL BE SHOWN ON ALUMINUM DIE-CASTING HOUSING STAMPED USING STAINLESS STEEL TAG PERMANENTLY ATTACHED TO THE DEVICE
 - HART COMMUNICATION SHALL BE SUITABLE OVER RANGE OF APPLICATION
 - AUSTENSIC 316 SS BOLTS REQUIRED
 - MOUNTING BRACKET FOR 2-IN PIPE BY VENDOR (AGCO)
 - LCD METER WITH POLYURETHANE COVERED ALUMINUM COVER REQUIRED
 - ALL DOCUMENTS TO BE SUBMITTED IN BOTH HARD AND ELECTRONIC FORMAT
 - INDICATOR TO SHOW BARG
 - MATERIAL SHALL BE PER APPROVED VENDOR LIST. MANUFACTURER LISTED ABOVE IS FOR REFERENCE.=
 - ELECTRICAL CONNECTION: M20 1/2" NPT
 - REQUIRED ASSEMBLY AS PER BELOW PICTURE WITH 2-WAY MANIFOLD OR ISOLATION VALVE=
 - TRANSMITTERS ARE SUPPLIED WITH THIN FILM TYPE PIEZORESISTIVE SENSORS
 - SENSOR FILLING: PAG SYNTHETIC OIL
 - REFER TO CONTROL NARRATIVE AND SET POINT LIST FOR THE CONTROLLER ACTION
 - HOUSING SHALL BE SELECTED TO SHOW TRANSMITTER LCD AT 90 DEGREE FROM INLET AS SHOWN BELOW.
 - REFER TO P&ID AND VALVE DATA SHEETS FOR 2-WAY MANIFOLD VALVE INFORMATION.

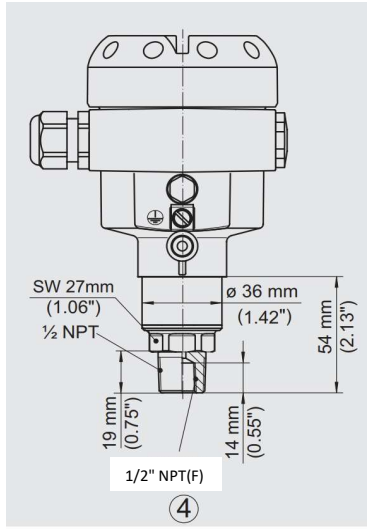

				TEMPERATURE TRANSMITTER CONTROL DEVICES				Document No: VD-GPIC-MA-3029-3029-0038		
CLIENT: Gachsaran Polymer Industries Company (GPIC) P.O. NO.: GPIC-PT-MA-PO-000-3029 SERVICE: PROPYLENE REFERIGERATION PACKAGE				Document Title: Instrument Data sheet & Catalogs		P.O.I.				
NO.	BY	APP	DATE							
00	N.B	A.M	12.10.25	IFR						
01	N.B	A.M	09.12.25	IFR						
02	N.B	A.M	12.02.26	IFR						
GENERAL				1 Tag No. SEE TABLE BELOW Service: SEE TABLE BELOW 2 Function Record <input type="checkbox"/> Indicate <input checked="" type="checkbox"/> Control <input checked="" type="checkbox"/> Blind <input type="checkbox"/> Trans <input checked="" type="checkbox"/> Other 3 Case MFR. Std. <input type="checkbox"/> Nom <input type="checkbox"/> Nom. Size Color: MFR. Std <input type="checkbox"/> Other NOTE 2 4 Mounting Flush <input type="checkbox"/> Surface <input type="checkbox"/> Yoke <input checked="" type="checkbox"/> Other RACK MOUNT 5 Enclosure Class Gen. Purpose <input type="checkbox"/> Weather Proof <input type="checkbox"/> Explosion Proof <input type="checkbox"/> Use in intrinsically <input checked="" type="checkbox"/> EExia Safe System <input type="checkbox"/> Other <input checked="" type="checkbox"/> IIB-T5 - ZONE 2, CL1 6 Power Supply 117V 60 Hz <input type="checkbox"/> Other ac DC <input checked="" type="checkbox"/> Volts 24 V 7 Chart Strip <input type="checkbox"/> Roll <input type="checkbox"/> Fold <input type="checkbox"/> Circular <input type="checkbox"/> Time marks <input type="checkbox"/> 8 Chart Drive Speed _____ Power _____ 9 Scale N/A Type: _____ Range: _____						
XMTR				10 Output NOTE 12 4-20 mA <input checked="" type="checkbox"/> 10-50mA <input type="checkbox"/> 21-103 kPa (3-15 psig) <input type="checkbox"/> Other For Receiver, see spec sheet. WIRED TO UCP VIA JUNCTION BOXES (2 WIRE OUTPUT) NOTE 12 P = Prop (Gain, 1-Integral (Auto Reset), D = Derivative (Rate) Sub: s = slow, f = fast, If <input type="checkbox"/> Df <input type="checkbox"/> P <input type="checkbox"/> PI <input type="checkbox"/> PD <input checked="" type="checkbox"/> PID <input type="checkbox"/> Is <input type="checkbox"/> Ds <input type="checkbox"/> Other _____ 12 Action On Measurement Increase, Output: Increases <input type="checkbox"/> Decreases <input type="checkbox"/> 13 Auto-Man Switch None <input type="checkbox"/> MFR Std <input type="checkbox"/> Other <input checked="" type="checkbox"/> NOTE 18 14 Set Point Adj. Manual <input type="checkbox"/> External <input type="checkbox"/> Remote <input checked="" type="checkbox"/> UCP NOTE 12 15 Manual Reg. None <input type="checkbox"/> MFR Std <input type="checkbox"/> Other _____ 16 Output 4-20 mA <input type="checkbox"/> 10-50mA <input type="checkbox"/> 21-103 kPa (3-15 psig) <input type="checkbox"/> Other _____						
CONTROLLER VIA PLC										
ELEMENT				17 Fill SAMA Class _____ Compensation _____ 18 Process Data SEE TABLE BELOW Compensation _____ 19 Range Fixed <input type="checkbox"/> Adj. Range <input type="checkbox"/> Set @ SEE BELOW Overrange Protection to: _____ Electrical Connection: M20 1/2" NPT 20 Bulb Type: RTD-Pt-100 α = 0.00385 Sheath Material: 316 S.S W/ MINERAL INSULATION Size: SEE TABLE BELOW Diameter: 1/4" Number of Wires: 3 WIRES (DUAL) NOTE 15 21 _____ 22 _____ 23 Alarm Switches Quantity: _____ Form _____ Rating _____ 24 Function Temp. <input checked="" type="checkbox"/> Deviation <input type="checkbox"/> Contacts to _____ On Temp. Incr. _____ 25 Options Filter Reg. _____ Sup Gage <input type="checkbox"/> Output Gage <input type="checkbox"/> Charts <input type="checkbox"/> 26 Other: _____ 27 AREA CLASS. IEC <input checked="" type="checkbox"/> ZONE 2, EExia IIB-T3 IP-65 / NEMA4X Agency Approval: ATEX						
TRANSMITTER										
Item	Qty	Tag No.	Temperature °F / °C		Oper. Press. PSIG BARG		Calibration (mA) °F / °C		Manufacturer / Model No.	Service
			Range	Oper.	Min.	Max.	4	20		
A	1	TT-61141	-328 to 1562	45.77	85.5	96.4	-58	212		HYDROCARBON GAS &
		ECONOMIZER	-200 to 850	7.65	5.90	6.6	-50	100		SYNTHETIC OIL
B										
C										
D										
E										

	TEMPERATURE TRANSMITTER CONTROL DEVICES				Document No: VD-GPIC-MA-3029-3029-0038
					Document Title: Instrument Data sheet & Catalogs
CLIENT: Gachsaran Polymer Industries Company (GPIC) P.O. NO.: GPIC-PT-MA-PO-000-3029 SERVICE: PROPYLENE REFRIGERATION PACKAGE	NO.	BY	APP	DATE	P.O.I.
	00	N.B	A.M	12.10.25	IFR
	01	N.B	A.M	09.12.25	IFR
	02	N.B	A.M	12.02.26	IFR

Item	Qty	Tag No.	Range °F (°C)	Oper. Temp. °F (°C)	LG (L) = (U+H) IN (mm)	Well Conn. Proc./Inst.	EXT. (N)	Ins (U) IN (mm)	LAG (H)	Well Type	Head Mtg	Model Number Sensor/Well
A	1	TE-61141 INLET	-148 to 842 -100 to 450	45.8 7.65	10 " 254 mm	1-1/2" - 300# RF 1/2" NPT	3.0 " 76.2	4.0 " 101.6	3.0 76.2	TAPERED NOTE 20	YES	
B												
C												
D												
E												

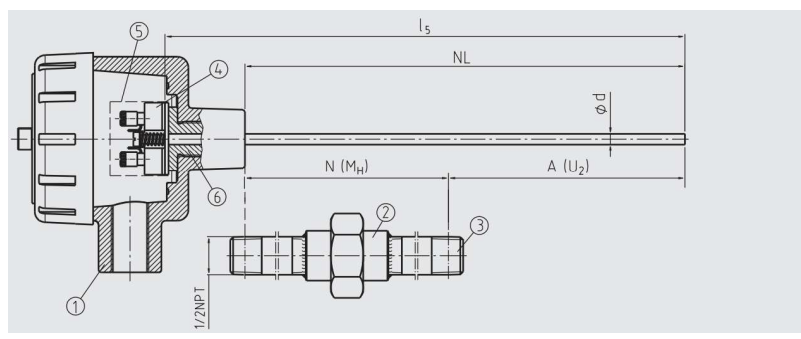
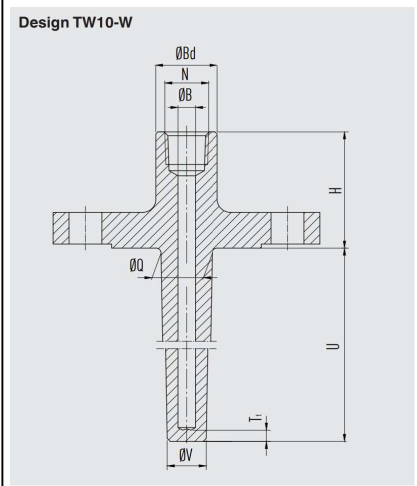
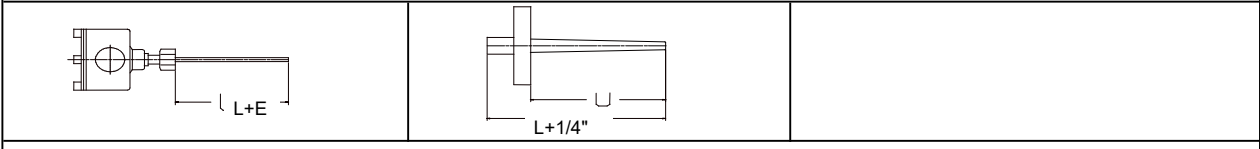

	TEMPERATURE TRANSMITTER CONTROL DEVICES				Document No: VD-GPIC-MA-3029-3029-0038
					Document Title: Instrument Data sheet & Catalogs
CLIENT: Gachsaran Polymer Industries Company (GPIC) P.O. NO.: GPIC-PT-MA-PO-000-3029 SERVICE: PROPYLENE REFERIGERATION PACKAGE	NO.	BY	APP	DATE	P.O.I.
	00	N.B	A.M	12.10.25	IFR
	01	N.B	A.M	09.12.25	IFR
	02	N.B	A.M	12.02.26	IFR

Notes:

- 1 SYSTEM DESIGN PRESSURE & TEMPERATURE:

FV to	362.5 PSIG	25.0 BarG	@	250 °F	121 °C	FOR ITEMS:	1
				-45 °F	-43 °C		
FV to	406 PSIG	28.0 BarG	@	250 °F	121 °C	FOR ITEMS:	
				-20 °F	-29 °C		
- 2 TRANSMITTER AND SENSOR ELECTRICAL HOUSING MUST BE POLYURETHANE COVERED DIE ALUMINUM-HOUSING, THERMOWELL IS 316 STAINLESS STEEL
- 3 REFERENCE ACCURACY: +/- 0.075 % OF FULL SCALE & +/- 0.15 % GUARRANTEED STABILITY OVER FIVE YEARS
- 4 INSTRUMENT SHALL BE SUITABLE FOR MARINE, SALT LADEN, CORROSIVE ENVIRONMENT
- 5 CALIBRATION CERTIFICATE REQUIRED NOT REQUIRED
- 6 HARD COPY OF IIEC-79, EE_xia IIB-T5 CERTIFICATE REQUIRED NOT REQUIRED PER IEC 60079
- 7 CUSTOMER SPECIFICATION: N/A & N/A
- 8 ELECTRICAL CLASS CERTIFICATION SHALL BE SHOWN ON ALUMINUM DIE-CASTING HOUSING STAMPED USING STAINLESS STEEL TAG PERMANENTLY ATTACHED TO THE DEVICE
- 9 ALL DOCUMENTS TO BE SUBMITTED IN BOTH HARD AND ELECTRONIC FORMAT
- 10 TERMINAL HEAD TO BE ASSEMBLED WITH THERMOWELL USING A UNION
- 11 EXTENSION SECTION OF 3 INCHES (76.2 mm) TO INCLUDE NIPPLE AND UNION
- 12 "SMART" ELECTRONIC TRANSMITTERS WITH "HART PROTOCOL" COMMUNICATION SHALL BE SUITABLE OVER RANGE OF APPLICATION-
- 13 EACH TEMPERATURE TRANSMITTER SHALL INCLUDE A MOUNTING BRACKET FOR 2-IN PIPE RACK
- 14 INDICATOR TO SHOW °C
- 15 MATERIAL SHALL BE PER APPROVED VENDOR LIST. MANUFACTURER LISTED ABOVE IS FOR REFERENCE.
- 15 BOTH RTD ELEMENTS ARE WIRED AND TERMINATED IN TERMINAL HEAD OR-TRANSMITTER-
- 16 REQUIRED ASSEMBLY AS PER BELOW PICTURES WITH A UNION. ELEMENT LENGTH SHALL BE ADJUSTED FOR THE UNION USE.
- 17 RTD TO BE TERMINATED IN THE TERMINAL HEAD, AND TRANSMITTER TO BE INSTALLED REMOTELY
- 18 REFER TO CONTROL NARRATIVE AND SET POINT LIST FOR THE CONTROLLER ACTION
- 19 THERMOWELL NATURAL FREQUENCE CALCULATION REQUIRED
- 20 THERMOWELL MATERIAL SHALL BE 316SS



THERMOWELL & HEAD



REMOTE TRANSMITTER WITH ELECTRONIC DISPLAY

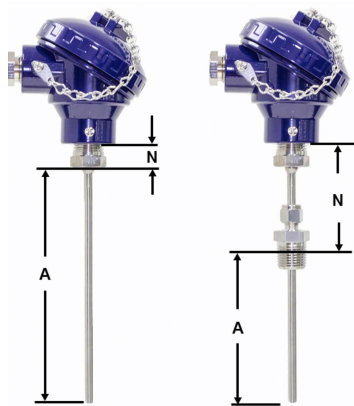



$A = U + H$

	TEMPERATURE TRANSMITTER INDICATOR DEVICES				Document No: VD-GPIC-MA-3029-3029-0038
					Document Title: Instrument Data sheet & Catalogs
CLIENT: Gachsaran Polymer Industries Company (GPIC) P.O. NO.: GPIC-PT-MA-PO-000-3029 SERVICE: PROPYLENE REFRIGERATION PACKAGE	NO.	BY	APP	DATE	P.O.I.
	00	N.B	A.M	12.10.25	IFR
	01	N.B	A.M	09.12.25	IFR
	02	N.B	A.M	12.02.26	IFR

SENSOR WITH THERMOWELL

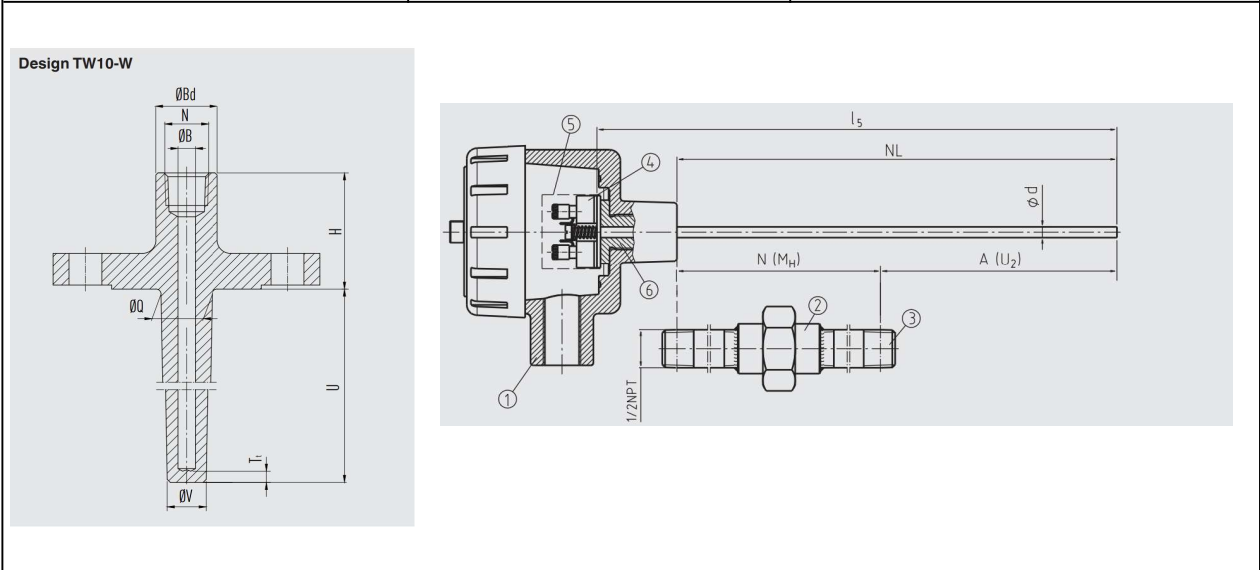
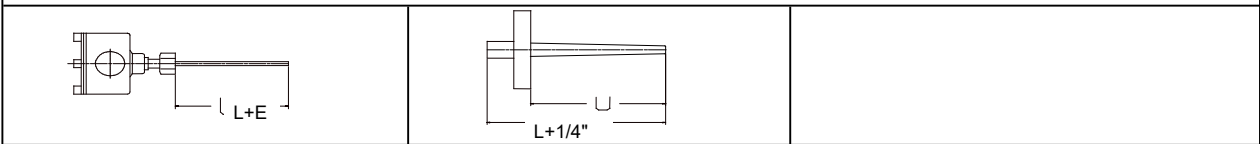
Item	Qty	Tag No.	Range °F (°C)	Oper. Temp. °F (°C)	LG (L) = (U+H) IN (mm)	Well Conn. Proc./Inst.	EXT. (N)	Ins (U) IN (mm)	LAG (H)	Well Type	Head Mtg	Model Number Sensor/Well
A	1	TE-61121 INLET	-148 to 842 -100 to 450	-12.4 -24.69	18 " 457 mm	1-1/2" - 300# RF 1/2" NPT	3.0 " 76.2	12.0 " 304.8	3.0 76.2	TAPERED NOTE 20	YES	
B												
C												
D												
E												



	TEMPERATURE TRANSMITTER INDICATOR DEVICES				Document No: VD-GPIC-MA-3029-3029-0038
					Document Title: Instrument Data sheet & Catalogs
CLIENT: Gachsaran Polymer Industries Company (GPIC) P.O. NO.: GPIC-PT-MA-PO-000-3029 SERVICE: PROPYLENE REFERIGERATION PACKAGE	NO.	BY	APP	DATE	P.O.I.
	00	N.B	A.M	12.10.25	IFR
	01	N.B	A.M	09.12.25	IFR
	02	N.B	A.M	12.02.26	IFR

Notes:

- 1 SYSTEM DESIGN PRESSURE & TEMPERATURE:

FV to 362.5 PSIG	25.0 BarG @	250 °F	121 °C	FOR ITEMS:	1
		-45 °F	-43 °C		
FV to 406 PSIG	28.0 BarG @	250 °F	121 °C	FOR ITEMS:	
		-20 °F	-29 °C		
- 2 TRANSMITTER AND SENSOR ELECTRICAL HOUSING MUST BE POLYURETHANE COVERED DIE ALUMINUM-HOUSING, THERMOWELL IS 316 STAINLESS STEEL
- 3 REFERENCE ACCURACY: +/- 0.075 % OF FULL SCALE & +/- 0.15 % GUARRANTEED STABILITY OVER FIVE YEARS
- 4 INSTRUMENT SHALL BE SUITABLE FOR MARINE, SALT LADEN, CORROSIVE ENVIRONMENT
- 5 CALIBRATION CERTIFICATE REQUIRED NOT REQUIRED
- 6 HARD COPY OF IIEC-79, EExia IIB-T5 CERTIFICATE REQUIRED NOT REQUIRED PER IEC 60079
- 7 CUSTOMER SPECIFICATION: N/A & N/A
- 8 ELECTRICAL CLASS CERTIFICATION SHALL BE SHOWN ON ALUMINUM DIE-CASTING HOUSING STAMPED USING STAINLESS STEEL TAG PERMANENTLY ATTACHED TO THE DEVICE
- 9 ALL DOCUMENTS TO BE SUBMITTED IN BOTH HARD AND ELECTRONIC FORMAT
- 10 TERMINAL HEAD TO BE ASSEMBLED WITH THERMOWELL USING A UNION
- 11 EXTENSION SECTION OF 3 INCHES (76.2 mm) TO INCLUDE NIPPLE AND UNION
- 12 "SMART" ELECTRONIC TRANSMITTERS WITH "HART PROTOCOL" COMMUNICATION SHALL BE SUITABLE OVER RANGE OF APPLICATION-
- 13 EACH TEMPERATURE TRANSMITTER SHALL INCLUDE A MOUNTING BRACKET FOR 2-IN PIPE RACK
- 14 INDICATOR TO SHOW °C
- 15 MATERIAL SHALL BE PER APPROVED VENDOR LIST. MANUFACTURER LISTED ABOVE IS FOR REFERENCE.
- 15 BOTH RTD ELEMENTS ARE WIRED AND TERMINATED IN TERMINAL HEAD OR-TRANSMITTER-
- 16 REQUIRED ASSEMBLY AS PER BELOW PICTURES WITH A UNION. ELEMENT LENGTH SHALL BE ADJUSTED FOR THE UNION USE.
- 17 RTD TO BE TERMINATED IN THE TERMINAL HEAD, AND TRANSMITTER TO BE INSTALLED REMOTELY
- 18 REFER TO CONTROL NARRATIVE AND SET POINT LIST FOR THE CONTROLLER ACTION
- 19 THERMOWELL NATURAL FREQUENCE CALCULATION REQUIRED
- 20 THERMOWELL MATERIAL SHALL BE 316SS



THERMOWELL & HEAD



REMOTE TRANSMITTER WITH ELECTRONIC DISPLAY

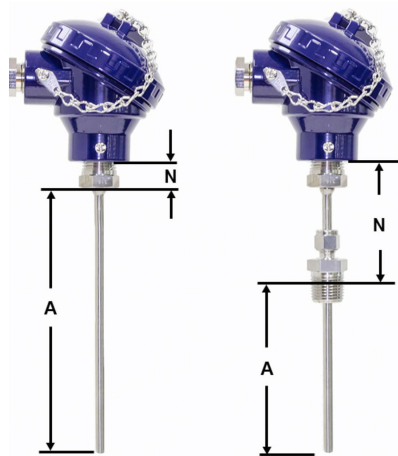

$A = U + H$

				TEMPERATURE TRANSMITTER INDICATOR DEVICES				Document No: VD-GPIC-MA-3029-3029-0038		
								Document Title: Instrument Data sheet & Catalogs		
				NO. BY APP DATE				P.O.I.		
CLIENT: Gachsaran Polymer Industries Company (GPIC) P.O. NO.: GPIC-PT-MA-PO-000-3029 SERVICE: PROPYLENE REFERIGERATION PACKAGE				00	N.B	A.M	12.10.25	IFR		
				01	N.B	A.M	09.12.25	IFR		
				02	N.B	A.M	12.02.26	IFR		
GENERAL				SEE TABLE BELOW Service: SEE TABLE BELOW						
1 Tag No.				Record <input type="checkbox"/> Indicate <input checked="" type="checkbox"/> Control <input type="checkbox"/> Blind <input type="checkbox"/> Trans <input checked="" type="checkbox"/> Other <input type="checkbox"/>						
2 Function				MFR. Std. <input type="checkbox"/> Nom <input type="checkbox"/> Nom. Size <input type="checkbox"/> Color: MFR. Std <input type="checkbox"/> Other NOTE 2						
3 Case				Flush <input type="checkbox"/> Surface <input type="checkbox"/> Yoke <input checked="" type="checkbox"/> Other RACK MOUNT						
4 Mounting				Gen. Purpose <input type="checkbox"/> Weather Proof <input type="checkbox"/> Explosion Proof <input type="checkbox"/>						
5 Enclosure Class				Use in intrinsically <input checked="" type="checkbox"/> EEExia Safe System <input type="checkbox"/> Other <input checked="" type="checkbox"/> IIB-T5 - ZONE 2, CL1						
6 Power Supply				117V 60 Hz <input type="checkbox"/> Other ac <input type="checkbox"/> DC <input checked="" type="checkbox"/> Volts 24 V						
7 Chart N/A				Strip <input type="checkbox"/> Roll <input type="checkbox"/> Fold <input type="checkbox"/> Circular <input type="checkbox"/> Time marks <input type="checkbox"/>						
8 Chart Drive				Speed <input type="checkbox"/> Power <input type="checkbox"/>						
9 Scale N/A				Type: _____ Range: _____						
XMTR				10 Output NOTE 12						
				4-20 mA <input checked="" type="checkbox"/> 10-50mA <input type="checkbox"/> 21-103 kPa (3-15 psig) <input type="checkbox"/> Other _____						
				For Receiver, see spec sheet. WIRED TO UCP VIA JUNCTION BOXES (2 WIRE OUTPUT) NOTE 12						
CONTROLLER VIA N/A				11 Control Modes						
				P = Prop (Gain), 1-Integral (Auto Reset), D = Derivative (Rate)						
				Sub: s = slow, f = fast, If <input type="checkbox"/> Df <input type="checkbox"/> P <input type="checkbox"/> PI <input type="checkbox"/> PD <input type="checkbox"/> PID <input type="checkbox"/> Is <input type="checkbox"/> Ds <input type="checkbox"/>						
				Other _____						
				12 Action On Measurement Increase, Output: Increases <input type="checkbox"/> Decreases <input type="checkbox"/>						
				13 Auto-Man Switch None <input type="checkbox"/> MFR Std <input type="checkbox"/> Other _____						
				14 Set Point Adj. Manual <input type="checkbox"/> External <input type="checkbox"/> Remote <input checked="" type="checkbox"/> UCP Other NOTE 12						
				15 Manual Reg. None <input type="checkbox"/> MFR Std <input type="checkbox"/> Other _____						
				16 Output 4-20 mA <input type="checkbox"/> 10-50mA <input type="checkbox"/> 21-103 kPa (3-15 psig) <input type="checkbox"/> Other _____						
ELEMENT				17 Fill SAMA Class _____ Compensation _____						
				18 Process Data SEE TABLE BELOW Compensation _____						
				19 Range Fixed <input type="checkbox"/> Adj. Range <input type="checkbox"/> Set @ SEE BELOW						
				Overrange Protection to: _____ Electrical Connection: M20 1/2" NPT						
				20 Bulb Type: RTD-Pt-100 α = 0.00385 Sheath Material: 316 S.S W/ MINERAL INSULATION						
				Size: SEE TABLE BELOW Diameter: 1/4" Number of Wires: 3 WIRES (DUAL) NOTE 15						
				21 _____						
				22 _____						
				23 Alarm Switches Quantity: _____ Form _____ Rating _____						
				24 Function Temp. <input checked="" type="checkbox"/> Deviation <input type="checkbox"/> Contacts to _____ On Temp. Incr. _____						
				25 Options Filter Reg. _____ Sup Gage <input type="checkbox"/> Output Gage <input type="checkbox"/> Charts <input type="checkbox"/>						
				26 Other: _____						
AREA CLASS.				27 IEC <input checked="" type="checkbox"/> ZONE 2, EEExia IIB-T3 IP-65 / NEMA4X Agency Approval: ATEX						
TRANSMITTER										
Item	Qty	Tag No.	Temperature °F / °C		Oper. Press. PSIG BARG		Calibration (mA) °F / °C		Manufacturer / Model No.	Service
			Range	Oper.	Min.	Max.	4	20		
A	1	TT-61111	-328 to 1562	-12.44	22.5	24.8	-58	212		HYDROCARBON GAS &
		SUCTION	-200 to 850	-24.69	1.55	1.69	-50	100		SYNTHETIC OIL
B	1	TT-61132	-328 to 1562	120	304.6	335.0	-58	212		HYDROCARBON GAS &
		OIL SUPPLY	-200 to 850	48.89	21.0	22.8	-50	100		SYNTHETIC OIL
C										
D	1	TT-61131	-328 to 1562	171.86	275.6	310.6	-58	212		HYDROCARBON GAS &
		OIL SEPARATOR	-200 to 850	77.70	19.0	21.1	-50	100		SYNTHETIC OIL
E										

	TEMPERATURE TRANSMITTER INDICATOR DEVICES				Document No: VD-GPIC-MA-3029-3029-0038
					Document Title: Instrument Data sheet & Catalogs
CLIENT: Gachsaran Polymer Industries Company (GPIC) P.O. NO.: GPIC-PT-MA-PO-000-3029 SERVICE: PROPYLENE REFERIGERATION PACKAGE	NO.	BY	APP	DATE	P.O.I.
	00	N.B	A.M	12.10.25	IFR
	01	N.B	A.M	09.12.25	IFR
	02	N.B	A.M	12.02.26	IFR

SENSOR WITH THERMOWELL

Item	Qty	Tag No.	Range °F (°C)	Oper. Temp. °F (°C)	LG (L) = (U+H) IN (mm)	Well Conn. Proc./Inst.	EXT. (N)	Ins (U) IN (mm)	LAG (H)	Well Type	Head Mtg	Model Number Sensor/Well
A	1	TE-61111 INLET	-148 to 842 -100 to 450	-12.4 -24.69	18 " 457 mm	1-1/2"- 300# RF 1/2" NPT	3.0 " 76.2	12.0 " 304.8	3.0 76.2	TAPERED NOTE 20	YES	
B		TE-61132 OIL SUPPLY	-148 to 842 -100 to 450	120.0 50	12 " 305 mm	1-1/2"- 300# RF 1/2" NPT	3.0 " 76.2	6.0 " 152.4	3.0 76.2	TAPERED NOTE 20	YES	
C												
D		TE-61131 OIL SEPARATOR	-148 to 842 -100 to 450	171.9 77.70	24 " 610 mm	1-1/2"- 300# RF 1/2" NPT	3.0 " 76.2	18.0 " 457.2	3.0 76.2	TAPERED NOTE 20	YES	
E												

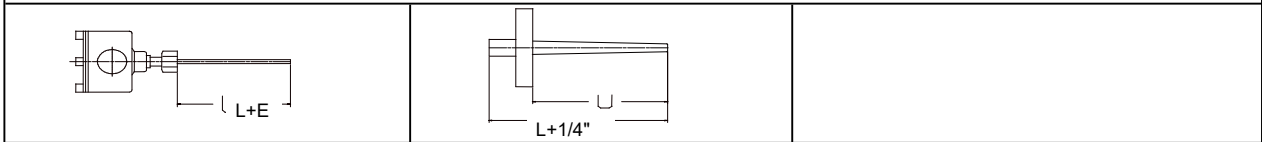

Design TW10-W

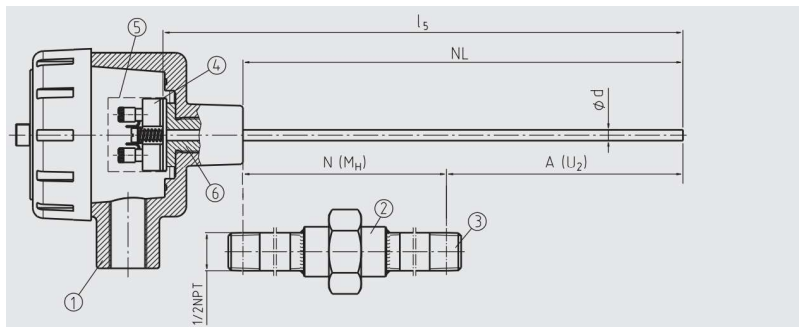
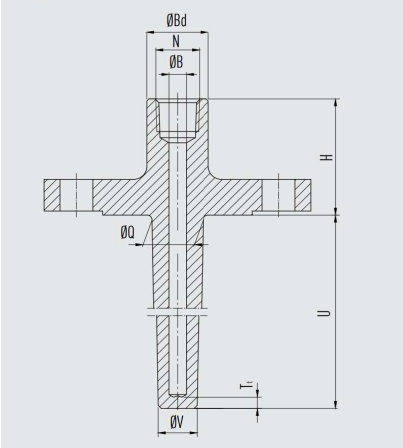

	TEMPERATURE TRANSMITTER INDICATOR DEVICES				Document No: VD-GPIC-MA-3029-3029-0038
					Document Title: Instrument Data sheet & Catalogs
CLIENT: Gachsaran Polymer Industries Company (GPIC) P.O. NO.: GPIC-PT-MA-PO-000-3029 SERVICE: PROPYLENE REFERIGERATION PACKAGE	NO.	BY	APP	DATE	P.O.I.
	00	N.B	A.M	12.10.25	IFR
	01	N.B	A.M	09.12.25	IFR
	02	N.B	A.M	12.02.26	IFR

Notes:

- 1 SYSTEM DESIGN PRESSURE & TEMPERATURE:

FV to	362.5 PSIG	25.0 BarG @	250 °F	121 °C	FOR ITEMS:	1, 3
			-45 °F	-43 °C		
FV to	406 PSIG	28.0 BarG @	250 °F	121 °C	FOR ITEMS:	2
			-20 °F	-29 °C		
- 2 TRANSMITTER AND SENSOR ELECTRICAL HOUSING MUST BE POLYURETHANE COVERED DIE ALUMINUM-HOUSING, THERMOWELL IS 316 STAINLESS STEEL
- 3 REFERENCE ACCURACY: +/- 0.075 % OF FULL SCALE & +/- 0.15 % GUARRANTEED STABILITY OVER FIVE YEARS
- 4 INSTRUMENT SHALL BE SUITABLE FOR MARINE, SALT LADEN, CORROSIVE ENVIRONMENT
- 5 CALIBRATION CERTIFICATE REQUIRED NOT REQUIRED
- 6 HARD COPY OF IIEC-79, EExia IIB-T5 CERTIFICATE REQUIRED NOT REQUIRED PER IEC 60079
- 7 CUSTOMER SPECIFICATION: N/A & N/A
- 8 ELECTRICAL CLASS CERTIFICATION SHALL BE SHOWN ON ALUMINUM DIE-CASTING HOUSING STAMPED USING STAINLESS STEEL TAG PERMANENTLY ATTACHED TO THE DEVICE
- 9 ALL DOCUMENTS TO BE SUBMITTED IN BOTH HARD AND ELECTRONIC FORMAT
- 10 TERMINAL HEAD TO BE ASSEMBLED WITH THERMOWELL USING A UNION
- 11 EXTENSION SECTION OF 3 INCHES (76.2 mm) TO INCLUDE NIPPLE AND UNION
- 12 "SMART" ELECTRONIC TRANSMITTERS WITH "HART PROTOCOL" COMMUNICATION SHALL BE SUITABLE OVER RANGE OF APPLICATION=
- 13 EACH TEMPERATURE TRANSMITTER SHALL INCLUDE A MOUNTING BRACKET FOR 2-IN PIPE RACK
- 14 INDICATOR TO SHOW °C
- 15 MATERIAL SHALL BE PER APPROVED VENDOR LIST. MANUFACTURER LISTED ABOVE IS FOR REFERENCE.
- 15 BOTH RTD ELEMENTS ARE WIRED AND TERMINATED IN TERMINAL HEAD OR-TRANSMITTER-
- 16 REQUIRED ASSEMBLY AS PER BELOW PICTURES WITH A UNION. ELEMENT LENGTH SHALL BE ADJUSTED FOR THE UNION USE.
- 17 RTD TO BE TERMINATED IN THE TERMINAL HEAD, AND TRANSMITTER TO BE INSTALLED REMOTELY
- 18 REFER TO CONTROL NARRATIVE AND SET POINT LIST FOR THE CONTROLLER ACTION
- 19 THERMOWELL NATURAL FREQUENCE CALCULATION REQUIRED
- 20 THERMOWELL MATERIAL SHALL BE 316SS



THERMOWELL & HEAD



REMOTE TRANSMITTER WITH ELECTRONIC DISPLAY

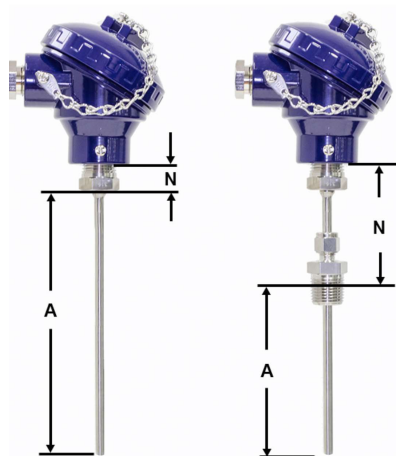

$A = U + H$

	GAUGES GLASSES & COCKS				Document No: VD-GPIC-MA-3029-3029-0038
					Document Title: Instrument Data sheet & Catalogs
CLIENT: Gachsaran Polymer Industries Company (GPIC) P.O. NO.: GPIC-PT-MA-PO-000-3029 SERVICE: PROPYLENE REFERIGERATION PACKAGE	NO.	BY	APP	DATE	P.O.I.
	00	N.B	A.M	12.10.25	IFR
	01	N.B	A.M	09.12.25	IFR
	02	N.B	A.M	12.02.26	IFR

1. Gage Column Assembled w/ Nipples Cocks Unassembled

GAGE CLASSES

2. Type: Reflex Transparent Tubular
 Large Chamber Weld Pad

3. Conn. Size & Type **2"-300# ANSI RF FLG**
 Top & Bottom Side Back
 Vent Drain

4. Material: Body / Cover **LT C.S. (SA350-LF2) OR SS**
 Glass **Borosilicate (TEMPERED)**

5. Min. Rating **SEE NOTES BELOW**

6. Options. Illuminator Mica Shield
 Internal Tube External Jkt.
 Non Frost External Length
 Calb. Scale Other

7. Manufacturer & Model:

GAGE COCKS

8. Type: Offset Straight
 9. Conn. Vessel **2"-300#** Gage **1/2"** Vent / Drain **1/2" W/VALVES**

10. Mat: Body: **S.S. A182** Trim: **316 SS**

11. Min. Rating: **507.5 PSIG @ 300 °F**

12. Construction: **INTEGRAL BALL-CHECK / UNION**

13. Type of Conn.: Vessel: **NPT (M) UNION CONNECTOR**
 Gage: **NPT (F) UNION CONNECTOR**
 Vent / Drain: **NPT (F)**
 Other: **DIRECT MOUNT**

14. Bonnet: **PACKING NUT / TEFLON PACKING**

15. Options: Ball Checks Renewal Seats
 Other: **RENEWAL SEATS**

16. Manufacturer & Model: **OTHERS**

17. Bolting Material: **A193-L7 / A194-7**

Item	Qty.	Tag No.	Visible Glass "V"	CONNECTION CENTER TO CENTER "X"	Model No.	Operating		Service
						Pressure PSIG (BarG)	Temp. °F (°C)	
A	1	LG-61141 RECEIVER HEADER	36.0 " 914 mm	36.0 " 914 mm	L21SR/1219.2/A2"300ibR F/N/Ex	268.4 18.5	117.3 47.4	PROPYLENE REFRIGERANT & SYNTHETIC OIL
B								
B								

	GAUGES GLASSES & COCKS				Document No: VD-GPIC-MA-3029-3029-0038
					Document Title: Instrument Data sheet & Catalogs
CLIENT: Gachsaran Polymer Industries Company (GPIC) P.O. NO.: GPIC-PT-MA-PO-000-3029 SERVICE: PROPYLENE REFERIGERATION PACKAGE	NO.	BY	APP	DATE	P.O.I.
	00	N.B	A.M	12.10.25	IFR
	01	N.B	A.M	09.12.25	IFR
	02	N.B	A.M	12.02.26	IFR

NOTES:	1	SYSTEM DESIGN PRESSURE & TEMPERATURE: FV to 362.5 PSIG 25.0 BarG @ 250 °F 121 °C -45 °F -43 °C
	2	WETTED MATERIAL IS 316L STAINLESS STEEL
	3	MATERIAL TEST REPORT TO INCLUDE CHARPY IMPACT TEST PER ASME & ASTM CODES
	4	INSTRUMENT SHALL BE SUITABLE FOR ON-SHORE SERVICE
	5	CALIBRATION CERTIFICATE <input type="checkbox"/> REQUIRED <input checked="" type="checkbox"/> NOT REQUIRED
	6	CERTIFICATE OF COMPLIANCE <input checked="" type="checkbox"/> REQUIRED <input type="checkbox"/> NOT REQUIRED
	7	316SS NAMEPLATE <input checked="" type="checkbox"/> REQUIRED <input type="checkbox"/> NOT REQUIRED
	8	CUSTOMER SPECIFICATION: N/A & N/A
	9	WHERE APPLICABLE, PMI REQUIRED PER SPECIFICATION.
	10	PAINTING PER CLIENT SPECIFICATION
	11	C TO C DISTA 48 inches 1,219.2 mm
	12	VENT AND DRAIN CONNECTION SHALL BE SUPPLIED WITH BALL VALVES

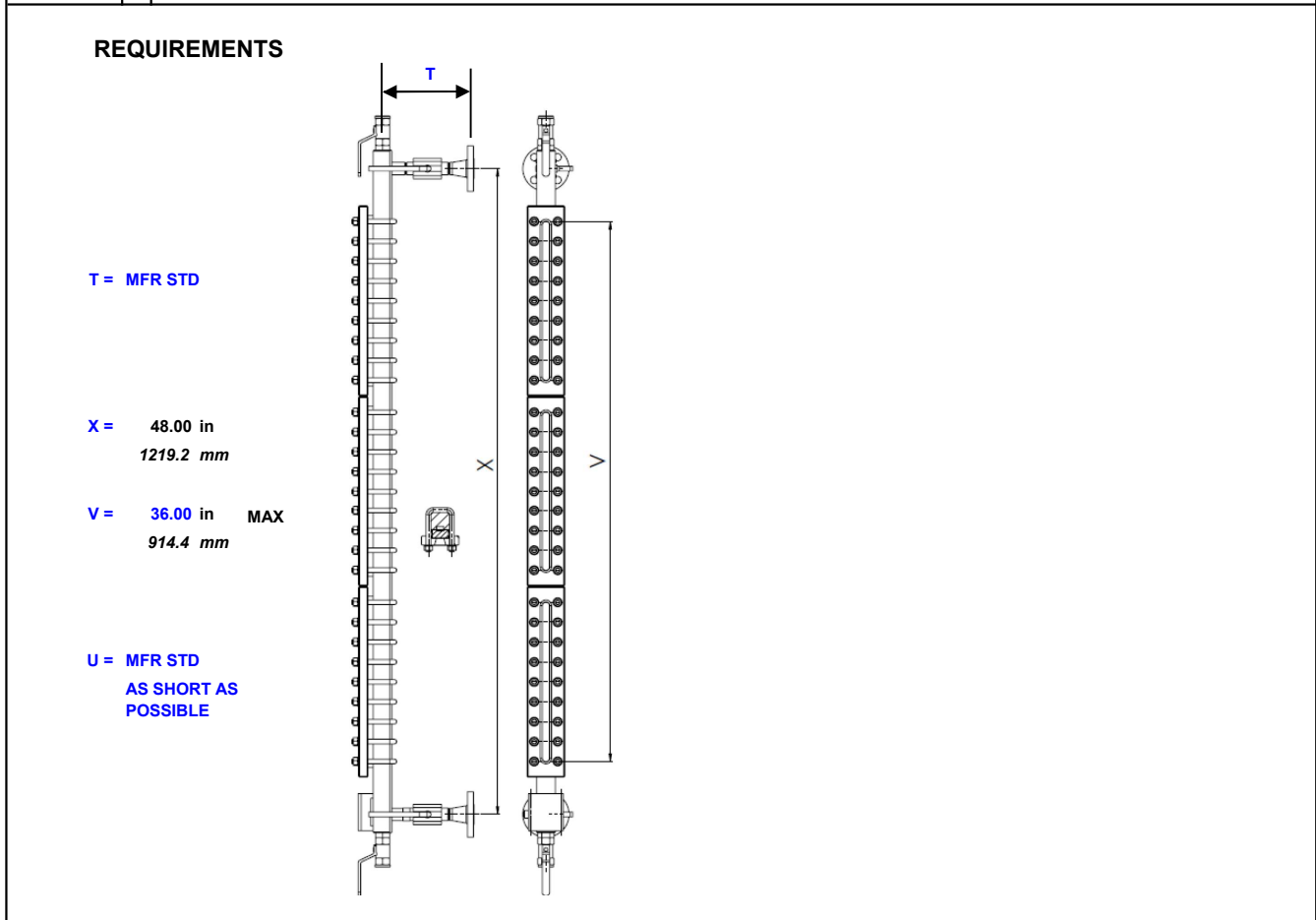

CLIENT: Gachsaran Polymer Industries Company (GPIC) P.O. NO.: GPIC-PT-MA-PO-000-3029 SERVICE: PROPYLENE REFERIGERATION PACKAGE	<table border="1" style="width:100%; border-collapse: collapse;"> <tr> <th>NO.</th> <th>BY</th> <th>APP</th> <th>DATE</th> <th>P.O.I.</th> </tr> <tr> <td>00</td> <td>N.B</td> <td>A.M</td> <td>12.10.25</td> <td>IFR</td> </tr> <tr> <td>01</td> <td>N.B</td> <td>A.M</td> <td>09.12.25</td> <td>IFR</td> </tr> <tr> <td>02</td> <td>N.B</td> <td>A.M</td> <td>12.02.26</td> <td>IFR</td> </tr> <tr> <td> </td> <td> </td> <td> </td> <td> </td> <td> </td> </tr> </table>	NO.	BY	APP	DATE	P.O.I.	00	N.B	A.M	12.10.25	IFR	01	N.B	A.M	09.12.25	IFR	02	N.B	A.M	12.02.26	IFR					
NO.	BY	APP	DATE	P.O.I.																						
00	N.B	A.M	12.10.25	IFR																						
01	N.B	A.M	09.12.25	IFR																						
02	N.B	A.M	12.02.26	IFR																						

GENERAL	1	Tag No.	SEE TABLE BELOW		Service: SEE TABLE BELOW	
	2	Qty				
	3	Function	Record <input type="checkbox"/>	Indicate <input checked="" type="checkbox"/>	Control <input checked="" type="checkbox"/>	VIA MCS Blind <input type="checkbox"/> Trans <input checked="" type="checkbox"/> Other
	4	Case	Mfr. Std. <input checked="" type="checkbox"/>	Nom. Size	Color :	<input type="checkbox"/> Other NOTE 2
	5	Mounting	Flush <input type="checkbox"/>	Surface <input checked="" type="checkbox"/>	Yoke <input type="checkbox"/>	Other
	6	Enclosure Class	Gen. Purpose <input type="checkbox"/>	Weather Proof <input type="checkbox"/>	Explosion Proof <input type="checkbox"/>	
			Use in intrinsically <input checked="" type="checkbox"/> EEExia	Safe System <input type="checkbox"/>	Other <input type="checkbox"/>	<input checked="" type="checkbox"/> IIB-T5 - ZONE 2, CL1
	7	Power Supply	117V 60 Hz <input checked="" type="checkbox"/>	Other ac <input type="checkbox"/>	DC <input checked="" type="checkbox"/>	Volts 24 V
	8	Chart	N/A	Strip <input type="checkbox"/> Roll <input type="checkbox"/> Fold <input type="checkbox"/>	Circular <input type="checkbox"/>	Time Marks <input type="checkbox"/>
	9	Chart Drive	N/A	Range	Number	Power

XMTR	11	Transmitter Output	4-20 mA <input checked="" type="checkbox"/>	10-50mA <input type="checkbox"/>	21-103 kPa (3-15 psig) <input type="checkbox"/>	Other
			For Receiver, see spec sheet. WIRED TO UCP VIA JUNCTION BOXES (2 WIRE OUTPUT) NOTE 18			

CONTROLLER VIA UCP	12	Control Modes	P = Prop (Gain), 1-Integral (Auto Reset), D = Derivative (Rate)			
			Sub: s = slow, f = fast,	lf <input type="checkbox"/>	Df <input type="checkbox"/>	P <input type="checkbox"/> PI <input type="checkbox"/> PD <input type="checkbox"/> PID <input checked="" type="checkbox"/> Is <input type="checkbox"/> Ds <input type="checkbox"/>
			Other			
	14	Action	On Measurement Increase, Output:		Increases <input type="checkbox"/>	Decreases <input type="checkbox"/>
	15	Auto-Man Switch	None <input type="checkbox"/>	MFR Std <input type="checkbox"/>	Other	
	16	Set Point Adj.	Manual <input type="checkbox"/>	External <input type="checkbox"/>	Remote <input type="checkbox"/>	Other
	17	Manual Reg.	None <input type="checkbox"/>	MFR Std <input type="checkbox"/>	Other	
	18	Output	NOTE 18	4-20 mA <input checked="" type="checkbox"/>	10-50 mA <input type="checkbox"/>	21-103 kPa (3-15 psig) <input type="checkbox"/> Other

ELEMENT	19	Service	Gage Press <input type="checkbox"/>	Vacuum <input type="checkbox"/>	Absolute <input type="checkbox"/>	Differential <input checked="" type="checkbox"/>
	20	Element Type	Diaphragm <input checked="" type="checkbox"/>	Helix <input type="checkbox"/>	Bourdon <input type="checkbox"/>	Bellows <input type="checkbox"/> Other
	21	Material (body)	316SS <input checked="" type="checkbox"/>	Ber Copper <input type="checkbox"/>	Other <input type="checkbox"/>	
	22	Range	Fixed <input type="checkbox"/>	Adj. Range <input checked="" type="checkbox"/>		
			Overrange Protection to:		SEE TABLE BELOW	Electrical Connection: M20 1/2"-NPT
	23	Process Data	Press.: Nor.:	SEE TABLE BELOW	MAX.:	Element Range:
	24	Process Conn.	1/4" in NPT <input type="checkbox"/>	1/2" in NPT (F) <input checked="" type="checkbox"/>	Other: 2"-300# ANSI RF FLG	

OPTIONS	25	Alarm Switches	Quantity:	Form	Rating	
	26	Function	Press. <input checked="" type="checkbox"/>	Deviation <input type="checkbox"/>	Contacts	On Icr. Meas.
	27	Options	Filter Reg. <input type="checkbox"/>	Sup. Gage <input type="checkbox"/>	Output Gage <input type="checkbox"/>	Charts
			Diaphragm Seal <input type="checkbox"/>	Type N/A	Diaphragm	Bot. Bowl
			Conn. N/A	Capillary: N/A	Length	Mtl.
			Other			

AREA CLASSIFICATION	IEC <input checked="" type="checkbox"/> ZONE 2, EEExia IIB-T3 IP-65 / NEMA4X Agency Approval: ATEX
----------------------------	--

Item	Qty	Tag No.	Pressure in (mm)		Operating Pressure PSIG / BarG		Calibration mA in (mm) NOTE 23		Manufacturer/ Model no.	Service
			Range	Over	Min	Max	4	20		
A	1	LT-61151 CHILLER	0.00 to 120.9 0 to 3,071	2000 137.9	22.5 1.55	25.9 1.79	0 0.00 0%	111.4 2,830.5 100%	CHAMBER: BNA- TRANSMITTER: BLM-	PROPYLENE REFRIGERANT SYNTHETIC OIL
B										
C										

	LEVEL TRANSMITTER INDICATOR DEVICES				Document No: VD-GPIC-MA-3029-3029-0038
					Document Title: Instrument Data sheet & Catalogs
CLIENT: Gachsaran Polymer Industries Company (GPIC) P.O. NO.: GPIC-PT-MA-PO-000-3029 SERVICE: PROPYLENE REFERIGERATION PACKAGE	NO.	BY	APP	DATE	P.O.I.
	00	N.B	A.M	12.10.25	IFR
	01	N.B	A.M	09.12.25	IFR
	02	N.B	A.M	12.02.26	IFR

GENERAL	1	Tag No.	SEE TABLE BELOW		Service: SEE TABLE BELOW	
	2	Qty				
	3	Function	Record <input type="checkbox"/>	Indicate <input checked="" type="checkbox"/>	Control <input type="checkbox"/>	VIA MCS <input type="checkbox"/> Blind <input type="checkbox"/> Trans <input checked="" type="checkbox"/> Other
	4	Case	Mfr. Std. <input checked="" type="checkbox"/>	Nom. Size	Color :	<input type="checkbox"/> Other NOTE 2
	5	Mounting	Flush <input type="checkbox"/>	Surface <input checked="" type="checkbox"/>	Yoke <input type="checkbox"/>	Other
	6	Enclosure Class	Gen. Purpose <input type="checkbox"/>	Weather Proof <input type="checkbox"/>	Explosion Proof <input type="checkbox"/>	
			Use in intrinsically <input checked="" type="checkbox"/>	Safe System <input type="checkbox"/>	Other <input type="checkbox"/>	<input checked="" type="checkbox"/> IIB-T5 - ZONE 2, CL1
	7	Power Supply	117V 60 Hz <input checked="" type="checkbox"/>	Other ac <input type="checkbox"/>	DC <input checked="" type="checkbox"/>	Volts 24 V
	8	Chart N/A	Strip <input type="checkbox"/>	Roll <input type="checkbox"/>	Fold <input type="checkbox"/>	Circular <input type="checkbox"/> Time Marks <input type="checkbox"/>
	9	Chart Drive N/A	Range	Speed	Number	Power
10	Scales	Type: LCD / DIGITAL	Range SEE TABLE BELOW			
XMTR	11	Transmitter Output	4-20 mA <input checked="" type="checkbox"/>	10-50mA <input type="checkbox"/>	21-103 kPa (3-15 psig) <input type="checkbox"/>	Other
			For Receiver, see spec sheet. WIRED TO UCP VIA JUNCTION BOXES (2 WIRE OUTPUT) NOTE 18			
CONTROLLER VIA N/A	12	Control Modes	P = Prop (Gain), 1-Integral (Auto Reset), D = Derivative (Rate) Sub: s = slow, f = fast, I f <input type="checkbox"/> I f <input type="checkbox"/> D f <input type="checkbox"/> P <input type="checkbox"/> PI <input type="checkbox"/> PD <input type="checkbox"/> PID <input type="checkbox"/> Is <input type="checkbox"/> Ds <input type="checkbox"/>			
	14	Action	On Measurement Increase, Output: Increases <input type="checkbox"/> Decreases <input type="checkbox"/>			
	15	Auto-Man Switch	None <input type="checkbox"/>	MFR Std <input type="checkbox"/>	Other	
	16	Set Point Adj.	Manual <input type="checkbox"/>	External <input type="checkbox"/>	Remote <input type="checkbox"/>	Other
	17	Manual Reg.	None <input type="checkbox"/>	MFR Std <input type="checkbox"/>	Other	
	18	Output NOTE 18	4-20 mA <input type="checkbox"/>	10-50 mA <input type="checkbox"/>	21-103 kPa (3-15 psig) <input type="checkbox"/>	Other
	19	Service	Gage Press <input type="checkbox"/>	Vacuum <input type="checkbox"/>	Absolute <input type="checkbox"/>	Differential <input checked="" type="checkbox"/>
	20	Element Type	Diaphragm <input checked="" type="checkbox"/>	Helix <input type="checkbox"/>	Bourdon <input type="checkbox"/>	Bellows <input type="checkbox"/> Other
ELEMENT	21	Material (body)	316SS <input checked="" type="checkbox"/>	Ber Copper <input type="checkbox"/>	Other <input type="checkbox"/>	
	22	Range	Fixed <input type="checkbox"/>	Adj. Range <input checked="" type="checkbox"/>	Overrange Protection to: SEE TABLE BELOW Electrical Connection: M20 1/2" NPT	
	23	Process Data	Press.: Nor.: SEE TABLE BELOW	MAX.:	Element Range:	
	24	Process Conn.	1/4" in NPT <input type="checkbox"/>	1/2" in NPT (F) <input checked="" type="checkbox"/>	Other: 2"-300# ANSI RF FLG	
	25	Alarm Switches	Quantity:	Form	Rating	
	26	Function	Press. <input checked="" type="checkbox"/>	Deviation <input type="checkbox"/>	Contacts	On Icr. Meas.
OPTIONS	27	Options	Filter Reg. <input type="checkbox"/>	Sup. Gage <input type="checkbox"/>	Output Gage <input type="checkbox"/>	Charts
			Diaphragm Seal <input type="checkbox"/>	Type N/A	Diaphragm	Bot. Bowl
			Conn. Capillary: N/A	Length	Mil.	
			Other			
AREA CLASSIFICATION			IEC <input checked="" type="checkbox"/> ZONE 2, EExia IIB-T3 IP-65 / NEMA4X	Agency Approval: ATEX		

Item	Qty	Tag No.	Pressure in (mm)		Operating Pressure PSIG / BarG		Calibration mA in (mm) NOTE 23		Manufacturer/ Model no.	Service
			Range	Over	Min	Max	4	20		
A	1	LT-61131 OIL SEPARATOR	0.00 to 57.4 0 to 1,459	2000 137.9	275.6 19.0	289.1 19.9	0 0.00 0%	48.0 1,214.4 100%	CHAMBER: BNA- TRANSMITTER: BLM-	NATURAL GAS & SYNTHETIC OIL
B										
C										

	LEVEL TRANSMITTER INDICATOR DEVICES				Document No: VD-GPIC-MA-3029-3029-0038
					Document Title: Instrument Data sheet & Catalogs
CLIENT: Gachsaran Polymer Industries Company (GPIC) P.O. NO.: GPIC-PT-MA-PO-000-3029 SERVICE: PROPYLENE REFERIGERATION PACKAGE	NO.	BY	APP	DATE	P.O.I.
	00	N.B	A.M	12.10.25	IFR
	01	N.B	A.M	09.12.25	IFR
	02	N.B	A.M	12.02.26	IFR

- Notes:**
- 1 SYSTEM DESIGN PRESSURE & TEMPERATURE: FV to 362.5 PSIG 25.0 BarG @ 250 °F 121 °C
-49 °F -45 °C
 - 2 NORMAL OPERATING CONDITIONS ARE: FV to 59.6 PSIG 4.1 BarG @ 158 °F 70 °C FOR ITEMS: 1
158 °F 70 °C FOR ITEMS:
 - 3 TRANSMITTER ELECTRICAL HOUSING MUST BE POLYURETHANE COVERED ALUMINUM
 - 4 REFERENCE ACCURACY: +/- 0.075 % OF FULL SCALE & +/- 0.15 % GUARRANTEED STABILITY OVER FIVE YEARS
 - 5 INSTRUMENT SHALL BE SUITABLE FOR MARINE, SALT LADEN, CORROSIVE ENVIRONMENT
 - 6 CALIBRATION CERTIFICATE REQUIRED NOT REQUIRED
 - 7 HARD COPY OF IIEC-79, EExia IIB-T5 CERTIFICATE REQUIRED NOT REQUIRED PER IEC 60079
 - 8 MATERIAL TEST REPORT REQUIRED NOT REQUIRED
 - 9 CUSTOMER SPECIFICATION: N/A, N/A & N/A
 - 10 ALL DOCUMENTS TO BE SUBMITTED IN BOTH HARD AND ELECTRONIC FORMAT
 - 11 INDICATOR TO SHOW PERCENTAGE
 - 12 AUSTENSIC 316 SS BOLTS REQUIRED
 - 13 NAMEPLATE TO BE MOUNTED TO TOP FLANGE
 - 14 HIGH PRESSURE SIDE, REMOTE MOUNT SEAL, PROCESS CONNECTION IS 2"-300# ANSI RF FLG.
 - 15 LIQUID DENSITY := 65= LB/FT3= 1044 KG/M3
 - 16 LOW PRESSURE SIDE, PROCESS CONNECTION 2"-300# ANSI RF FLG
 - 17 LCD METER WITH POLYURETHANE COVERED ALUMINUM COVER REQUIRED
 - 18 "SMART" ELECTRONIC TRANSMITTERS WITH "HART PROTOCOL" COMMUNICATION SHALL BE SUITABLE OVER RANGE OF APPLICATION=
 - 19 ELECTRICAL CLASS CERTIFICATION SHALL BE SHOWN ON A DIE-STAMPED STAINLESS STEEL TAG PERMANENTLY ATTACHED TO THE DEVICE=
 - 20 ELECTRICAL CONNECTION: M20
 - 21 LIQUID MEDIA IS PAG OIL WITH OPERATING CONDITIONS SHOWN IN TABULATION
 - 22 DISTANCE BETWEEN NOZZLES THAT COVERS THE TRANSMITTER CALIBRATION RANGE IS: 48.00 inches 1,214.4 mm
 - 23 IT IS THE RESPONSIBILITY OF THE SUPPLIER TO ASSURE THAT THE FLOATS FIT INSIDE THE CHAMBER
 - 24 TRANSMITTER ORIENTATION SHALL AS PER SHOWN PER BELOW SNAPSHOT CALLED "ACTUAL DESIGN"

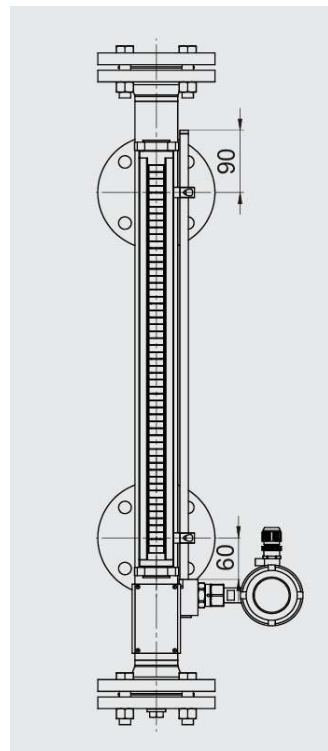

REQUIREMENTS

- X = 14.4 in 365.76 mm
- T = MFR STD
- M = 48.00 in 1,219.2 mm
- U = MFR STD AS SHORT AS POSSIBLE
- Z = 1 in 25.4 mm

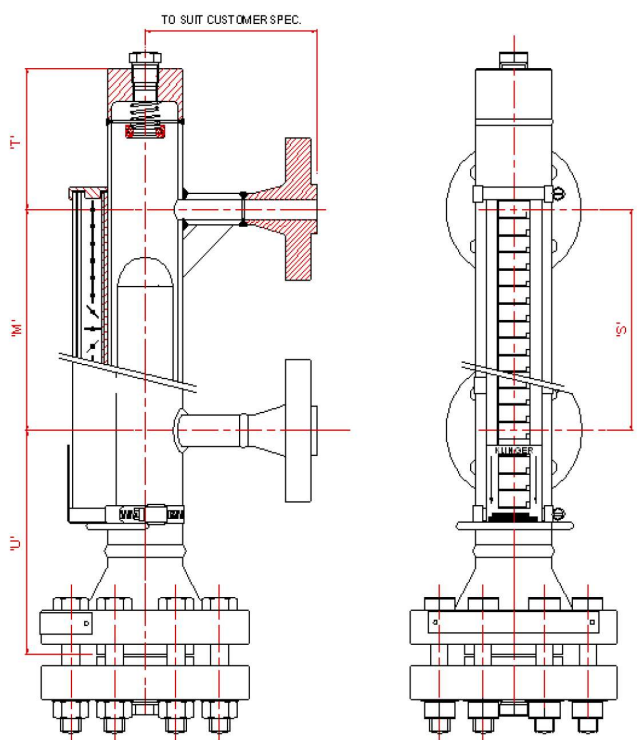



SIGHT INDICATOR (ROTAMETER)				Document No:	VD-GPIC-MA-3029-3029-0038
				Document Title:	Instrument Data sheet & Catalogs
NO.	BY	APP	DATE	P.O.I.	
00	N.B	A.M	12.10.25	IFR	
01	N.B	A.M	09.12.25	IFR	
02	N.B	A.M	12.02.26	IFR	

CLIENT: Gach saran Polymer Industries Company (GPIC)
 P.O. NO.: GPIC-PT-MA-PO-000-3029
 SERVICE: PROPYLENE REFRIGERATION PACKAGE

Item No.	A				B				C
Tag No.	SI-701-O-4 RECEIVER				FG-61131 OIL DEPARATOR				
Connections									
Inlet	3/4"-300# ANSI RF				1-1/2"-300# ANSI RF				
Outlet	3/4"-300# ANSI RF				1-1/2"-300# ANSI RF				
Rating	300#				300#				
Drawing									
P&ID	ULT003-20001-4				ULT003-20001-3				
Type									
Mounting	IN-LINE HORIZONTALLY MOUNTED				IN-LINE HORIZONTALLY MOUNTED				
Construction	BULL'S EYE TYPE (DUAL WINDOW)				BULL'S EYE TYPE (DUAL WINDOW)				
Type	ROTOR				ROTOR				
Material									
Body	STAINLESS STEEL - A351-CF8				STAINLESS STEEL - A351-CF8				
Glass	TEMPERED BOROSILICATE GLASS (SHATTER PROOF)				TEMPERED BOROSILICATE GLASS (SHATTER PROOF)				
Seal/Elastomer	TEFLON				TEFLON				
Bolts / Nuts	SA193-B7 / SA194-2H				SA193-B8 / SA194-8				
Service									
Media	SYNTHETIC OIL / PROPYLENE REFRIGERANT				SYNTHETIC OIL / PROPYLENE REFRIGERANT				
Phase	LIQUID / VAPOR				GAS / VAPOR				
Operating Conditions									
Pressure	270.2	PSIG	18.6	BarG	270.7	18.67	BarG		
Temperature	116.96	°F	47.2	°C	171	77.2	°C		
Manufacture									
Model									
Quantity	2				2				

Notes:

1 SYSTEM DESIGN PRESSURE & TEMPERATURE: FV to 362.5 PSIG 25.0 BarG @ 250 °F 121 °C
 MINIMUM DESIGN TEMPERATURE -45 °F -43 °C FOR: 3
 -20 °F -29 °C FOR: 1

2 WETTED MATERIAL IS 316 STAINLESS STEEL

3 INSTRUMENT SHALL BE SUITABLE FOR MARINE, SALT LADEN, CORROSIVE ENVIRONMENT

4 CALIBRATION CERTIFICATE REQUIRED NOT REQUIRED

5 CERTIFICATE OF COMPLIANCE REQUIRED NOT REQUIRED

6 316SS NAMEPLATE REQUIRED NOT REQUIRED

7 NACE-MR-0475 RATED

8 ALL DOCUMENTS TO BE SUBMITTED IN BOTH HARD AND ELECTRONIC FORMAT

9 BOLTS / NUTS SHALL BE CADMIUM PLATED

10 INDIVIDUAL PART WEIGHT MUST BE CERTIFIED

11 WHERE APPLICABLE, PMI REQUIRED PER SPECIFICATION

12 INSPECTION PER STATED CODES

13 STAINLESS STEEL MATERIAL CAN BE QUOTED IF CARBON STEEL IS NOT AVAILABLE=

14 HYDROSTATIC CERTIFICATE REQUIRED FOR ALL VALVES

15 INLET AND OUTLET BORES SHALL MATCH WITH SCH80 PIPE





CLIENT: Gachsaran Polymer Industries Company (GPIC) P.O. NO.: GPIC-PT-MA-PO-000-3029 SERVICE: PROPYLENE REFERIGERATION PACKAGE	NO.	BY	APP	DATE	P.O.I.
	00	N.B	A.M	12.10.25	IFR
	01	N.B	A.M	09.12.25	IFR
	02	N.B	A.M	12.02.26	IFR

GENERAL	1	Tag No.	SEE TABLE BELOW		Service: See Table Below
	2	Function	Record <input type="checkbox"/>	Indicate <input checked="" type="checkbox"/>	Control <input checked="" type="checkbox"/> Blind <input type="checkbox"/> Trans <input checked="" type="checkbox"/> Other
	3	Case	MFR. Std. <input checked="" type="checkbox"/>	Nom <input type="checkbox"/>	Nom. Size Color: MFR. Std <input checked="" type="checkbox"/> Other NOTE 2
	4	Mounting	Flush <input type="checkbox"/>	Surface <input type="checkbox"/>	Yoke <input type="checkbox"/> Other RACK MOUNT
	5	Enclosure Class	Gen. Purpose <input type="checkbox"/>	Weather Proof <input checked="" type="checkbox"/>	Explosion Proof <input checked="" type="checkbox"/> IIB-T3 - ZONE 2, CL1
	6	Power Supply	117V 60 Hz <input type="checkbox"/>	Other ac	dc <input checked="" type="checkbox"/> Volts: 24 V
	7	Chart	Strip <input type="checkbox"/>	Roll <input type="checkbox"/>	Fold <input type="checkbox"/> Circular <input type="checkbox"/> Time marks <input type="checkbox"/>
	8	Chart Drive	Speed _____ Power _____		
	9	Scale	Type: _____	Range: 0 - 2000 OHMS	
XMTR	10	Transmitter Output	4-20 mA <input checked="" type="checkbox"/>	10-50mA <input type="checkbox"/>	21-103 kPa (3-15 psig) <input type="checkbox"/> Other
			For Receiver, see spec sheet. WIRED TO PLC VIA I/O RACK (2 WIRES OUTPUT)		
CONTROLLER VIA PLC	11	Control Modes	Sub: s = slow, f = fast, _____ If <input type="checkbox"/> Df <input type="checkbox"/> P <input type="checkbox"/> PI <input type="checkbox"/> PD <input type="checkbox"/> PID <input type="checkbox"/> Is <input type="checkbox"/> Ds <input type="checkbox"/>		
			Other _____		
	12	Action	None <input type="checkbox"/>	MFR Std <input checked="" type="checkbox"/>	Increases <input type="checkbox"/> Decreases <input type="checkbox"/>
	13	Auto-Man Switch	Manual <input type="checkbox"/>	External <input checked="" type="checkbox"/>	Remote <input checked="" type="checkbox"/> Other
	14	Set Point Adj.	None <input type="checkbox"/>	MFR Std <input checked="" type="checkbox"/>	Other
	15	Manual Reg.	4-20 mA <input checked="" type="checkbox"/>	10-50mA <input type="checkbox"/>	21-103 kPa (3-15 psig) <input type="checkbox"/> Other
	16	Output			
ELEMENT	17	Fill	SAMA Class _____ Compensation _____		
	18	Process Data	SEE TABLE BELOW		
	19	Range	Fixed <input checked="" type="checkbox"/>	Adj. Range 0-1000 ohms	Set @ SEE BELOW
			Instrument Connection: _____ Electrical Connection: M20 1/2" NPT		
	20	Bulb	Type: POTENTIOMETER (0-5 VDC)	Sheat Material: _____	
			Size: _____	Diameter: _____	Number of Wires: 3-WIRES
	21				
	22				
	23	Alarm Switches	Quantity: 1 / TRANSMITTER	Form SOFT	Rating VIA PLC
	24	Function	Resistor <input checked="" type="checkbox"/>	Deviation <input type="checkbox"/>	Contacts to _____ On Temp. Incr.
	25	Options	Other: DIGITAL DISPLAY		
AREA CLASS.	27		IEC <input checked="" type="checkbox"/>	ZONE 2, EExia IIB-T3 IP-65 / NEMA4X Agency Approval: ATEX	

TRANSMITTER										
Item	Qty	Tag No.	Resistance (ohms)		Oper. Press. (PSIG)		Calibration (ohms)		Manufacturer / Model No.	Service
			Range	Oper.	Min.	Max.	4 mA	20 mA		
A	1	ZT-61111	0-2000	0-1000	ATM	ATM	0	1000		HYDROCARBON GAS & SYNTHETIC OIL
B	1	ZT-61121	0-2000	0-1000	ATM	ATM	0	1000		HYDROCARBON GAS & SYNTHETIC OIL

- Notes:**
- 1 SYSTEM DESIGN PRESSURE & TEMPERATURE: 300 °F 149 °C
 - 2 ACCURACY: **+/- 0.02** % FS
 - 3 INSTRUMENT SHALL BE SUITABLE FOR MARINE, SALT LADEN, CORROSIVE ENVIRONMENT
 - 4 CALIBRATION CERTIFICATE REQUIRED NOT REQUIRED
 - 5 HARD COPY OF **IIEC-79, EExia IIB-T5** CERTIFICATE REQUIRED NOT REQUIRED PER IEC 60079
 - 6 CUSTOMER SPECIFICATION: 1400-20-IC-SP-5102
 - 7
 - 8= ELECTRICAL CLASS CERTIFICATION SHALL BE SHOWN ON A DIE-STAMPED STAINLESS STEEL TAG PERMANENTLY ATTACHED TO THE DEVICE=
 - 9= "SMART" ELECTRONIC TRANSMITTERS SHALL BE SUITABLE OVER RANGE OF APPLICATION
 - 10= ALL HARDWARE SHALL BE 316 SS
 - 11= ALL DOCUMENTS TO BE SUBMITTED IN ELECTRONIC FORMAT
 - 12= AUSTENSIC 316 SS BOLTS REQUIRED
 - 13
 - 14= BRACKET FOR 2" PIPE OR PANEL MOUNTING OF STAINLESS STEEL CONSTRUCTION REQUIRED
 - 15= LCD METER WITH STAINLESS STEEL COVER REQUIRED
 - 16= INDIVIDUAL PART WEIGHT MUST BE CERTIFIED

				SOLENOID VALVE (CAPACITY CONTROL)		Document No:	VD-GPIC-MA-3029-3029-0038	
						Document Title:	Instrument Data sheet & Catalogs	
				NO.	BY	APP	DATE	P.O.I.
CLIENT: Gachsaran Polymer Industries Company (GPIC) P.O. NO.: GPIC-PT-MA-PO-000-3029 SERVICE: PROPYLENE REFERIGERATION PACKAGE				00	N.B	A.M	12.10.25	IFR
				01	N.B	A.M	09.12.25	IFR
				02	N.B	A.M	12.02.26	IFR
GENERAL	0	Item No.	A					
	1	Tag No.	LOAD	XY-61112		& XY-61122		
			UNLOAD	XY-61111		& XY-61121		
	2	Service	AIR					
	3	Line No. / Vessel No.	COMPRESSOR LOADING / UNLOADING					
4	Valve No.	DIRV-61111 DIRV-61111						
VALVE BODY	5	Type	3 WAY DIRECT ACTING w/ QUICK EXHAUST					
	6	Size - Body / Port	1/4" / 3					
	7	Rating & Type Connection	NPT					
	8	Material - Body	316 STAINLESS STEEL					
	9	Material - Disc (Trim)	BUNA (HIGH NITRILE)					
	10	Material-Diaphragm / Coil	EPOXY MOLDED					
	11	Operation - Direct/Pilot	DIRECT					
	12	Packless or Type Packed	----					
	13	Manual Reset Lever	----					
	14	Manual Operator(override)	INCLUDED					
	15							
	WHEN DE-ENERGIZE	17	2-Ways Valve Opens/Close	---				
18		3-Way (NOTE 10)	YES					
19		Vent Port Opens/Close	OPENS					
20		Pressure Port Opens/Close	CLOSES					
21		4-Way	----					
22		Pressure to Cyl. 1/ Cyl. 2	----					
23		Exh. from Cyl. 1/ Cyl. 2	----					
24								
25								
SOLENOID		26	Enclosure	IEC-79, Eex(d) IIB-T3 IP66 (NEMA-4X)				
	27	Voltage/Hz	24 VDC (LOW POWER OPERATOR)					
	28	Style of Coil	CL. "H" HERMETICALLY SEALED HIGH TEMP.					
	29	Single or Double Coil	SINGLE					
	30	Area Classification	IEC-79, ZONE 2, GROUP IIB, T3, EE x(d)					
	31	Cable Entry	M20 x 1.5 mm					
SERVICE CONDITION	32	Fluid	AIR					
	33	Qty., Max	8	SCFM	12.7	S M3/HR		
	34	Operating Differential Min/Max	10	/ 15	PSID	0.7 / 1.03	BarD	
	35	Allow . Differential Min/Max	20	/ 150	PSID	1.4 / 10.3	BarD	
	36	Temperature Norm/Max	70	/ 100	°F	21 / 37.8	°C	
	37	Operating Specific Gravity	1.0					
	38	Operating Viscosity	-----					
	39	Required Cv	0.200					
	40	Valve Cv / Orifice	0.8 /					
	41							
	42	Agency Approval	ATEX					
	43							
	44							
	45	Manufacturer						
46	Model No.							
47	QTY	4						
NOTES:	1	SYSTEM DESIGN PRESSURE & TEMPERATURE:						
	2		150	PSIG	10	BarG	@ 300 °F 149 °C	
	3						-20 °F -29 °C	
	4	INSTRUMENT SHALL BE SUITABLE FOR MARINE, SALT LADEN, CORROSIVE ENVIRONMENT						
	5	CALIBRATION CERTIFICATE	<input type="checkbox"/>	REQUIRED	<input checked="" type="checkbox"/>	NOT REQUIRED		
	6	CERTIFICATE OF COMPLIANCE	<input checked="" type="checkbox"/>	REQUIRED	<input type="checkbox"/>	NOT REQUIRED		
	7	HARD COPY OF IEC-79, EEXD IIB-T3 CERTIFICATE	<input checked="" type="checkbox"/>	REQUIRED	<input type="checkbox"/>	NOT REQUIRED	PER IEC 60079	
	8	AREA CLASSIFICATION:	IEC-79, ZONE 2, GROUP IIB, T3, EE x(d)					
	9	MANUFACTURER CALCULATION / SIZING SHEET	<input type="checkbox"/>	REQUIRED	<input checked="" type="checkbox"/>	NOT REQUIRED		
	10	STAINLESS STEEL NAMEPLATE (316)	<input checked="" type="checkbox"/>	REQUIRED	<input type="checkbox"/>	NOT REQUIRED		
	11	COILS SHALL BE FITTED WITH SURGE SUPPRESSION DIODES.						
	12	SOLENOID VALVE POWER CONSUMPTION SHALL BE LESS THAN 10 WATTS.						
	13	BUG SCREENS SHALL BE INSTALLED ON EXHAUST						
	14	LEADS TO BE TERMINATED IN A CONDUIT BOX SUITABLE FOR AREA CLASSIFICATION.						
	15	ALL DOCUMENTS TO BE SUBMITTED IN BOTH HARD AND ELECTRONIC FORMAT						
	INDIVIDUAL PART WEIGHT MUST BE CERTIFIED							

			SOLENOID VALVE (CAPACITY CONTROL)		Document No:	VD-GPIC-MA-3029-3029-0038	
					Document Title:	Instrument Data sheet & Catalogs	
			NO.	BY	APP	DATE	P.O.I.
CLIENT: Gachsaran Polymer Industries Company (GPIC) P.O. NO.: GPIC-PT-MA-PO-000-3029 SERVICE: PROPYLENE REFRIGERATION PACKAGE			00	N.B	A.M	12.10.25	IFR
			01	N.B	A.M	09.12.25	IFR
			02	N.B	A.M	12.02.26	IFR
GENERAL	0	Item No.	A				
	1	Tag No.	XV-61151 XV-61152				
	2	Service	OIL				
	3	Line No. / Vessel No.	OIL RECOVERY SYSTEM				
	4	Valve No.	N/A				
VALVE BODY	5	Type (NOTE 16)	2 WAY DIRECT ACTING w/ QUICK EXHAUST				
	6	Size - Body / Port	1/2" / 2				
	7	Rating & Type Connection	NPT				
	8	Material - Body	316 STAINLESS STEEL				
	9	Material - Disc (Trim)	VITON				
	10	Material-Diaphragm / Coil	EPOXY MOLDED				
	11	Operation - Direct/Pilot	DIRECT				
	12	Packless or Type Packed	----				
	13	Manual Reset Lever	----				
	14	Manual Operator(override)	INCLUDED				
	15						
WHEN DE-ENERGIZE	17	2-Ways Valve Opens/Close	YES				
	18	3-Way (NOTE 10)	NO				
	19	Vent Port Opens/Close	N/A				
	20	Pressure Port Opens/Close	CLOSES				
	21	4-Way	----				
	22	Pressure to Cyl. 1/ Cyl. 2	----				
	23	Exh. from Cyl. 1/ Cyl. 2	----				
	24						
SOLENOID	26	Enclosure	IEC-79, Eex(d) IIB-T3 IP66 (NEMA-4X)				
	27	Voltage/Hz	24 VDC (LOW POWER OPERATOR)				
	28	Style of Coil	CL. "H" HERMETICALLY SEALED HIGH TEMP.				
	29	Single or Double Coil	SINGLE				
	30	Area Classification	IEC-79, ZONE 2, GROUP IIB, T3, EE x(d)				
	31	Cable Entry	M20 x 1.5 mm				
SERVICE CONDITION	32	Fluid	OIL (PAG) / PROPYLENE				
	33	Qty., Max	5	GPM	19	LPM	
	34	Operating Differential Min/Max	1	/	5	PSID 0.1 / 0.345 BarD	
	35	Allow . Differential Min/Max	5	/	290	PSID 0.3 / 20 BarD	
	36	Temperature Norm/Max	-12.4	/	145	°F -25 / 62.78 °C	
	37	Operating Specific Gravity	0.96				
	38	Operating Viscosity	----				
	39	Required Cv	2.191				
	40	Valve Cv / Orifice	3.80				
	41						
	42	Agency Approval	ATEX				
	43						
	44						
	45	Manufacturer					
46	Model No.						
47	QTY	2					
NOTES:	1	SYSTEM DESIGN PRESSURE & TEMPERATURE: FV to 362.5 PSIG 25.0 BarG @ 250 °F 121 °C					
	2						
	3	INSTRUMENT SHALL BE SUITABLE FOR MARINE, SALT LADEN, CORROSIVE ENVIRONMENT					
	4	CALIBRATION CERTIFICATE <input type="checkbox"/> REQUIRED <input checked="" type="checkbox"/> NOT REQUIRED					
	5	CERTIFICATE OF COMPLIANCE <input checked="" type="checkbox"/> REQUIRED <input type="checkbox"/> NOT REQUIRED					
	6	HARD COPY OF IEC-79, EEXD IIB-T3 CERTIFICATE <input checked="" type="checkbox"/> REQUIRED <input type="checkbox"/> NOT REQUIRED PER IEC 60079					
	7	AREA CLASSIFICATION: IEC-79, ZONE 2, GROUP IIB, T3, EE x(d)					
	8	MANUFACTURER CALCULATION / SIZING SHEET <input type="checkbox"/> REQUIRED <input checked="" type="checkbox"/> NOT REQUIRED					
	9	STAINLESS STEEL NAMEPLATE (316) <input checked="" type="checkbox"/> REQUIRED <input type="checkbox"/> NOT REQUIRED					
	10	COILS SHALL BE FITTED WITH SURGE SUPPRESSION DIODES.					
	11	SOLENOID VALVE POWER CONSUMPTION SHALL BE LESS LESS THAN 10 WATTS.					
	12	BUG SCREENS SHALL BE INSTALLED ON EXHAUST					
	13	LEADS TO BE TERMINATED IN A CONDUIT BOX SUITABLE FOR AREA CLASSIFICATION.					
	14	ALL DOCUMENTS TO BE SUBMITTED IN BOTH HARD AND ELECTRONIC FORMAT					
	15	INDIVIDUAL PART WEIGHT MUST BE CERTIFIED					
	16	3-WAY VALVES MAY BE USED BY PLUGGING BLEED PORT.					

				RESTRICTION ORIFICE		Document No:	VD-GPIC-MA-3029-3029-0038		
						Document Title:	Instrument Data sheet & Catalogs		
				NO.	BY	APP	DATE		
							P.O.I.		
CLIENT	Gachsaran Polymer Industries Company (GPIC)			00	N.B	A.M	12.10.25	IFR	
	JOB No.	Gachsaran HDPE			01	N.B	A.M	09.12.25	IFR
	P.O. No.	GPIC-PT-MA-PO-000-3029			02	N.B	A.M	12.02.26	IFR
	SERVICE	PROPYLENE REFRIGERATION PACKAGE							
ORIFICE PLATE 1. Type Concentric <input type="checkbox"/> Other <input type="checkbox"/> 2. Standard ISA <input type="checkbox"/> MFR Standard <input checked="" type="checkbox"/> 3. Bore Maximum Rate <input type="checkbox"/> Nearest 1/8" <input type="checkbox"/> 4. Material 304 SS <input type="checkbox"/> 316 SS <input type="checkbox"/> 316L SS <input checked="" type="checkbox"/> Other <input type="checkbox"/> 5. Ring Material & Type PADDLE 6. MFR & Model DELTA				ORIFICE FLANGE 15. Taps Flange <input checked="" type="checkbox"/> Vena Contracta <input type="checkbox"/> Pipe <input type="checkbox"/> Other <input type="checkbox"/> 16. Flange Type WN <input checked="" type="checkbox"/> SO <input type="checkbox"/> NPT <input type="checkbox"/> 17. Flange Material 304 <input type="checkbox"/> 316 SS <input type="checkbox"/> Other <input checked="" type="checkbox"/> 316L SS 18. Flange Included Yes <input type="checkbox"/> No <input checked="" type="checkbox"/> 19. Rating: 150# RF <input type="checkbox"/> 300# RF <input checked="" type="checkbox"/> Other <input type="checkbox"/>					
GENERAL				Page 27 of 29					
	13	Tag No.		RO-61141					
	14	Qty		1					
	15	Service		CONDENSER COOLING MEDIA					
	16	Line No. / Vessel No.		8" - 8"-CS300-CS1-CWR-60511					
	17	Fluid		COOLING WATER					
	18	Fluid State		LIQUID					
	19	Maximum Flow		1341 GPM		304,500 kg/h			
	20	Normal Flow		1277 GPM		290,000 kg/h			
	21	Inlet pressure (Norm, Max)		77.45 PSIG / 85 PSIG		5.34 BARG / 5.9 BARG			
		Outlet pressure (Norm, Max)		71.27 PSIG / 78 PSIG		4.92 BARG / 5.4 BARG			
	22	Temperature (Norm, Max)		98 °F / 103 °F		36.67 °C / 39.4 °C			
	23	Specific Gravity at Base							
	24	Operating Specific Gravity							
	25	Supercomp. Gravity		---					
	26	Molecular Weight		---					
	27	Operating Viscosity / Density		0.713 Cp		53.24 LB/FT3 855.3 kg/m3			
	28	Quality % or Superheat		---					
	29	Base Pressure		---					
	30	Base Temperature		---					
	31	Discharge Pressure (Downstream)		71.27 PSIG		4.92 BARG			
	32	Differential Pressure		6.18 PSID		0.43 BARG			
METER	33	Type of Meter		N/A					
	34	Diff. Range - Dry		---					
	35	Seal Sp. Gr. @ 60 °F		---					
	36	Static Pressure Range		---					
	37	Chart or Scale Range		---					
	38	Chart Multiplier		---					
	39								
	40								
	41								
	PLATE & FLANGE	42	Beta = d/D		0.330				
43		Orifice Bore Diameter		2.625 in		66.68 mm			
44		Nozzle Size / Schedule		8 / 8"-SCH40					
45		Flange Rating		300# ANSI RF					
46		Vent or Drain Hole		N/A					
47		Plate Thickness		0.25 in		6.35 mm			
48		Plate Material		316LSS					
49									
	50	Manufacturer		DELTA					
	50	Model No.		PADDLE TYPE					
NOTES:	1	SYSTEM DESIGN PRESSURE & TEMPERATURE:		406 PSIG		@ 300 °F			
				28.0 BARG		@ 148.9 °C			
	2	CERTIFICATE OF COMPLIANCE		<input checked="" type="checkbox"/> REQUIRED		<input type="checkbox"/> NOT REQUIRED			
	3	MTRs ARE REQUIRED							
4									

				RESTRICTION ORIFICE			Document No:	VD-GPIC-MA-3029-3029-0038	
							Document Title:	Instrument Data sheet & Catalogs	
				NO.	BY	APP	DATE	P.O.I.	
CLIENT Gachsaran Polymer Industries Company (GPIC) JOB No. Gachsaran HDPE P.O. No. GPIC-PT-MA-PO-000-3029 SERVICE PROPYLENE REFRIGERATION PACKAGE				00	N.B	A.M	12.10.25	IFR	
				01	N.B	A.M	09.12.25	IFR	
				02	N.B	A.M	12.02.26	IFR	
ORIFICE PLATE 1. Type Concentric <input type="checkbox"/> Other <input type="checkbox"/> 2. Standard ISA <input type="checkbox"/> MFR Standard <input checked="" type="checkbox"/> 3. Bore Maximum Rate <input type="checkbox"/> Nearest 1/8" <input type="checkbox"/> 4. Material 304 SS <input type="checkbox"/> 316 SS <input type="checkbox"/> 316L SS <input checked="" type="checkbox"/> Other <input type="checkbox"/> 5. Ring Material & Type PADDLE 6. MFR & Model DELTA				ORIFICE FLANGE 15. Taps Flange <input checked="" type="checkbox"/> Vena Contracta <input type="checkbox"/> Pipe <input type="checkbox"/> Other <input type="checkbox"/> 15. Tap Size 1/2" <input type="checkbox"/> Other <input checked="" type="checkbox"/> 1" 16. Flange Type WN <input checked="" type="checkbox"/> SO <input type="checkbox"/> NPT <input type="checkbox"/> 17. Flange Material 304 <input type="checkbox"/> 316 SS <input type="checkbox"/> Other <input checked="" type="checkbox"/> 316L SS 18. Flange Included Yes <input type="checkbox"/> No <input checked="" type="checkbox"/> 19. Rating: 150# RF <input type="checkbox"/> 300# RF <input checked="" type="checkbox"/> Other <input type="checkbox"/>					
GENERAL	13	Tag No.	RO-61131						
	14	Qty	1						
	15	Service	COMPRESSOR OIL COOLER COOLING MEDIA						
	16	Line No. / Vessel No.	3" - 3"-CS300-CS1-CWR-60311						
	17	Fluid	COOLING WATER						
	18	Fluid State	LIQUID						
	19	Maximum Flow	185 GPM						
	20	Normal Flow	176 GPM						
	21	Inlet pressure (Norm, Max)	77.45 PSIG / 85 PSIG			5.34 BARG / 5.9 BARG			
	21	Outlet pressure (Norm, Max)	74.45 PSIG / 82 PSIG			5.13 BARG / 5.6 BARG			
	22	Temperature (Norm, Max)	98 °F / 103 °F			36.67 °C / 39.4 °C			
	23	Specific Gravity at Base							
	24	Operating Specific Gravity							
	25	Supercomp. Gravity	---						
	26	Molecular Weight	---						
	27	Operating Viscosity / Density	0.713 Cp		/ 53.24 LB/FT3		855.3 kg/m3		
	28	Quality % or Superheat	---						
	29	Base Pressure	---						
	30	Base Temperature	---						
	31	Discharge Pressure (Downstream)	74.45 PSIG		5.13 BARG				
	32	Differential Pressure	3.00 PSID		0.21 BARG				
	METER	33	Type of Meter	N/A					
34		Diff. Range - Dry	---						
35		Seal Sp. Gr. @ 60 °F	---						
36		Static Pressure Range	---						
37		Chart or Scale Range	---						
38		Chart Multiplier	---						
39									
40									
41									
PLATE & FLANGE	42	Beta = d/D	0.243						
	43	Orifice Bore Diameter	1 in		/ 25.40 mm				
	44	Nozzle Size / Schedule	4		/ 4"-SCH40				
	45	Flange Rating	300# ANSI RF						
	46	Vent or Drain Hole	N/A						
	47	Plate Thickness	0.125 in		/ 3.18 mm				
	48	Plate Material	316LSS						
	50	Manufacturer	DELTA						
	50	Model No.	PADDLE TYPE						
NOTES:	1	SYSTEM DESIGN PRESSURE & TEMPERATURE:		406 PSIG @ 300 °F		28.0 BARG @ 148.9 °C			
	2	CERTIFICATE OF COMPLIANCE		<input checked="" type="checkbox"/> REQUIRED		<input type="checkbox"/> NOT REQUIRED			
	3	MTRs ARE REQUIRED							
	4								