



 Gachsaran Polymer Industries Company PIDMCO	Gachsaran Polymer Industries Company HDPE Plant				
	Instruments Hookup Diagram and MTO for Refrigerator Package		 		
PO No.: GPIC-PT-MA-PO-000-3029	Document Number: VD-GPIC-MA-3029-3029-0051	Rev. 01	Page 1 of 39		

Instruments Hookup Diagram and MTO for Refrigerator Package

Code1	<input type="checkbox"/> No Comment/ Approved (Applicable Only for "FOR REVIEW" and "For Approval" Documents) No comment and the document are released for Manufacturing.
Code2	<input type="checkbox"/> No Comment/ Approved with Note(s) Vendor/Sub-Contractor shall correct, revise and resubmit the document. The document is released for Manufacturing if changes incorporated.
Code3	<input type="checkbox"/> Commented Vendor/Sub-Contractor shall correct, revise and resubmit the document by the date specified. The document shall be revised under the Status of "R: Revised Issue". All corrected documents shall be resubmitted before starting the Manufacturing Process.
Code 4	<input type="checkbox"/> Not Accepted (Rejected) Vendor/Sub-Contractor shall re-work / re-design / re-specify the contents of the document according to the comments / reasons for rejection. All corrected documents shall be resubmitted before starting the manufacturing. Vendor/Sub-Contractor shall not proceed with subsequent works of Material Supply or Manufacturing until receiving Code1/Code2 or No Code from PURCHASER. Vendor/Sub-Contractor shall resubmit the document with the same revision within 6 working days after receiving comments.
No code	<input checked="" type="checkbox"/> No Code (Applicable Only for "For Information" Documents and "As Built DWGs") Document has been submitted for PURCHASER's Information (FI). Consistency, completeness and correctness of document content is in Vendor/Sub-Contractor's responsibility.
Above checking results by EIED shall in no way relieve Vendor of any liability, obligation and responsibility out of the purchase order and the mutual agreement in writing.	
 EIED Energy Industries Engineering & Design co.	Date: Feb.23, 2026 Dept.: MA Signature: F.Hamooni

01	8-Feb-26	IFI	DSH	F.T	A.M
00	9-Dec-25	IFI	DSH	F.T	A.M
Rev.	DATE	PURPOSE OF ISSUE	PREPARED	CHECKED	APPROVED

Long Description (Family)	Spec	Size	Line Number Ta
TUBING, 1/2" , 0.065" THK , LENGTH 28'-8 3/4" , ASTM A269 , SEAMLESS	316 SS Tubing	1/2"	DIR-61111
Male Connector 3/4" NPT(M) x 1/2" T	316 SS Tubing	3/4"x1/2"	DIR-61111
Direction Vale. 1/2"	316 SS Tubing	1/2"x1/4"	DIR-61111
MaleConnector 1/2 NPT(M) x 1/2"Tube	316 SS Tubing	1/2"	DIR-61111
Male Connector 3/4" NPT(M) x 1/2" T	316 SS Tubing	3/4"x1/2"	DIR-61111
MaleConnector 1/2 NPT(M) x 1/2"Tube	316 SS Tubing	1/2"	DIR-61111
STUB 1/2NPT(M) x 1/2"Tube	316 SS Tubing	1/2"	DIR-61111
Union Elbow 1/2" T x 1/2"T	316 SS Tubing	1/2"	DIR-61111
MaleStub1/2NPT(M) x 1/2"Tube	316 SS Tubing	1/2"	DIR-61111
FCV 1/2" NPT(F) x 1/2" NPT(F)	316 SS Tubing	1/2"	DIR-61111
MaleConnector 1/2NPT(M) x 1/2"Tube	316 SS Tubing	1/2"	DIR-61111
STUB 1/2NPT(M) x 1/2"Tube	316 SS Tubing	1/2"	DIR-61111
Union Elbow 1/2" T x 1/2"T	316 SS Tubing	1/2"	DIR-61111
MaleStub1/2NPT(M) x 1/2"Tube	316 SS Tubing	1/2"	DIR-61111
FCV 1/2" NPT(F) x 1/2" NPT(F)	316 SS Tubing	1/2"	DIR-61111
MaleConnector 1/2NPT(M) x 1/2"Tube	316 SS Tubing	1/2"	DIR-61111
MaleStub1/2NPT(M) x 1/2"Tube	316 SS Tubing	1/2"	DIR-61111
Union Elbow 1/2" T x 1/2"T	316 SS Tubing	1/2"	DIR-61111
MaleStub1/2NPT(M) x 1/2"Tube	316 SS Tubing	1/2"	DIR-61111
Union Elbow 1/2" T x 1/2"T	316 SS Tubing	1/2"	DIR-61111
Solenoid, 1/4" to 1/2"	316 SS Tubing	1/2"	DIR-61111
Solenoid, 1/4" to 1/2"	316 SS Tubing	1/2"	DIR-61111
Regulator-1/4"	316 SS Tubing	1/4"	DIR-61111
STUB 1/4NPT(M) x 1/2"Tube	316 SS Tubing	1/2"x1/4"	DIR-61111
Union ELB, Tubing, 1/4" to 1"	316 SS Tubing	1/2"	DIR-61111
STUB 1/4NPT(M) x 1/2"Tube	316 SS Tubing	1/2"x1/4"	DIR-61111
Union ELB, Tubing, 1/4" to 1"	316 SS Tubing	1/2"	DIR-61111
MaleConnector 1/4NPT(M) x 1/2"Tube	316 SS Tubing	1/2"	DIR-61111
Union_TEE_1/4" to 1"	316 SS Tubing	1/2"	DIR-61111
MaleConnector 1/4NPT(M) x 1/2"Tube	316 SS Tubing	1/2"	DIR-61111
MaleConnector 1/4NPT(M) x 1/2"Tube	316 SS Tubing	1/2"	DIR-61111
MaleConnector 1/4NPT(M) x 1/2"Tube	316 SS Tubing	1/2"	DIR-61111
MaleConnector 1/4NPT(M) x 1/2"Tube	316 SS Tubing	1/2"	DIR-61111
MaleConnector 1/4NPT(M) x 1/2"Tube	316 SS Tubing	1/2"	DIR-61111
MaleConnector 1/2NPT(M) x 1/2"Tube	316 SS Tubing	1/2"	DIR-61111
TUBING, 1/2" , 0.065" THK , LENGTH 26'-5 3/16" , ASTM A269 , SEAMLESS	316 SS Tubing	1/2"	DIR-61121
Male Connector 3/4" NPT(M) x 1/2" T	316 SS Tubing	3/4"x1/2"	DIR-61121
Male Connector 3/4" NPT(M) x 1/2" T	316 SS Tubing	3/4"x1/2"	DIR-61121
MaleStub 1/2" NPT(M) x 1/2"Tube	316 SS Tubing	1/2"	DIR-61121

Direction Vale. 1/2"	316 SS Tubing	1/2"x1/4"	DIR-61121
Male Connector 1/2" NPT(M) x 1/2" T	316 SS Tubing	1/2"	DIR-61121
Male Connector, 316SS. NPT(M) x Tube	316 SS Tubing	1/4"	DIR-61121
Male Connector 1/2" NPT(M) x 1/2" T	316 SS Tubing	1/2"x1/4"	DIR-61121
MaleStub1/2NPT(M) x 1/2"Tube	316 SS Tubing	1/2"	DIR-61121
Union Elbow 1/2" T x 1/2"T	316 SS Tubing	1/2"	DIR-61121
Union Elbow 1/2" T x 1/2"T	316 SS Tubing	1/2"	DIR-61121
MaleStub1/2NPT(M) x 1/2"Tube	316 SS Tubing	1/2"	DIR-61121
FCV 1/2" NPT(F) x 1/2" NPT(F)		1/2"	DIR-61121
MaleConnector 1/2NPT(M) x 1/2"Tube	316 SS Tubing	1/2"	DIR-61121
MaleStub 1/2" NPT(M) x 1/2"Tube	316 SS Tubing	1/2"	DIR-61121
Union Elbow 1/2" T x 1/2"T	316 SS Tubing	1/2"	DIR-61121
MaleStub1/2NPT(M) x 1/2"Tube	316 SS Tubing	1/2"	DIR-61121
FCV 1/2" NPT(F) x 1/2" NPT(F)		1/2"	DIR-61121
MaleConnector 1/2NPT(M) x 1/2"Tube	316 SS Tubing	1/2"	DIR-61121
MaleStub1/2NPT(M) x 1/2"Tube	316 SS Tubing	1/2"	DIR-61121
Union Elbow 1/2" T x 1/2"T	316 SS Tubing	1/2"	DIR-61121
Solenoid, 1/4" NPT(F)	316 SS Tubing	1/2"	DIR-61121
Solenoid, 1/4" NPT(F)	316 SS Tubing	1/2"	DIR-61121
Regulator-1/4" NPT(F)	316 SS Tubing	1/4"	DIR-61121
Male Connector 1/4" NPT(M) x 1/2" T	316 SS Tubing	1/2"	DIR-61121
MaleStub 1/4" NPT(M) x 1/2"Tube	316 SS Tubing	1/2"x1/4"	DIR-61121
Union ELB, Tubing, 1/4" to 1"	316 SS Tubing	1/2"	DIR-61121
MaleStub 1/4" NPT(M) x 1/2"Tube	316 SS Tubing	1/2"x1/4"	DIR-61121
Union ELB, Tubing, 1/4" to 1"	316 SS Tubing	1/2"	DIR-61121
Union_TEE_1/4" to 1"	316 SS Tubing	1/2"	DIR-61121
Male Connector 1/4" NPT(M) x 1/2" T	316 SS Tubing	1/2"	DIR-61121
Male Connector 1/4" NPT(M) x 1/2" T	316 SS Tubing	1/2"	DIR-61121
MaleConnector 1/2NPT(M) x 1/2"Tube	316 SS Tubing	1/2"	DIR-61121
Male Connector 1/4" NPT(M) x 1/2" T	316 SS Tubing	1/2"	DIR-61121
Male Connector 1/4" NPT(M) x 1/2" T	316 SS Tubing	1/2"	DIR-61121
Male Connector 1/4" NPT(M) x 1/2" T	316 SS Tubing	1/2"	DIR-61121
TUBING, 1/2" , 0.065" THK , LENGTH 1'-5 7/8" , ASTM A269 , SEAMLESS	316 SS Tubing	1/2"	PG-61138
PRESSURE GAUGE 1/2" NPT(M)		1/2"	PG-61138
2-Way-Manifold	316 SS Tubing	1/2"	PG-61138
PLUG, HEX HEAD, MPT, ASME B16.11	316 SS Tubing	1/2"	PG-61138
MaleConnector 1/2NPT(M) x 1/2"Tube	316 SS Tubing	1/2"	PG-61138
FemaleConnector 1/2NPT(F) x 1/2"Tube	316 SS Tubing	1/2"	PG-61138
Female Sub 1/2"NPT(F) x 1/2"Tube	316 SS Tubing	1/2"	PG-61138
MaleStub1/2NPT(M) x 1/2"Tube	316 SS Tubing	1/2"	PG-61138

Union Elbow 1/2" T x 1/2"T	316 SS Tubing	1/2"	PG-61138
TUBING, 1/2" , 0.065" THK , LENGTH 7 1/16" , ASTM A269 , SEAMLESS	316 SS Tubing	1/2"	PG-61139
2-Way-Manifold	316 SS Tubing	1/2"	PG-61139
PLUG, HEX HEAD, MPT, ASME B16.11	316 SS Tubing	1/2"	PG-61139
MaleConnector 1/2NPT(M) x 1/2"Tube	316 SS Tubing	1/2"	PG-61139
FemaleConnector 1/2NPT(F) x 1/2"Tube	316 SS Tubing	1/2"	PG-61139
Female Sub 1/2"NPT(F) x 1/2"Tube	316 SS Tubing	1/2"	PG-61139
PRESSURE GAUGE 1/2" NPT(M)		1/2"	PG-61139
MaleConnector 1/2 NPT(M) x 1/2"Tube	316 SS Tubing	1/2"	PG-61139
TUBING, 1/2" , 0.065" THK , LENGTH 5'-0 7/8" , ASTM A269 , SEAMLESS	316 SS Tubing	1/2"	PT-61111
Male Connector 3/4" NPT(M) x 1/2" T	316 SS Tubing	3/4"x1/2"	PT-61111
2-Way-Manifold	316 SS Tubing	1/2"	PT-61111
PLUG, HEX HEAD, 1/2" NPT (M), ASME B16.11	316 SS Tubing	1/2"	PT-61111
MaleStub1/2NPT(M) x 1/2"Tube	316 SS Tubing	1/2"	PT-61111
MaleConnector 1/2NPT(M) x 1/2"Tube	316 SS Tubing	1/2"	PT-61111
FemaleConnector 1/2NPT(F) x 1/2"Tube	316 SS Tubing	1/2"	PT-61111
PRESSURE TRANSMITTER 1/2" NPT(F), PIT-RU600105		1/2"	PT-61111
2-Way-Manifold	316 SS Tubing	1/2"	PT-61111
PLUG, HEX HEAD, 1/2" NPT (M), ASME B16.11	316 SS Tubing	1/2"	PT-61111
MaleConnector 1/2NPT(M) x 1/2"Tube	316 SS Tubing	1/2"	PT-61111
FemaleConnector 1/2NPT(F) x 1/2"Tube	316 SS Tubing	1/2"	PT-61111
Female Sub 1/2"NPT(F) x 1/2"Tube	316 SS Tubing	1/2"	PT-61111
PRESSURE GAUGE 1/2" NPT(M)		1/2"	PT-61111
Union_TEE_1/4" to 1"	316 SS Tubing	1/2"	PT-61111
TUBING, 1/2" , 0.065" THK , LENGTH 3'-0 13/16" , ASTM A269 , SEAMLESS	316 SS Tubing	1/2"	PT-61113
2-Way-Manifold	316 SS Tubing	1/2"	PT-61113
PLUG, HEX HEAD, 1/2" NPT (M), ASME B16.11	316 SS Tubing	1/2"	PT-61113
MaleStub1/2NPT(M) x 1/2"Tube	316 SS Tubing	1/2"	PT-61113
MaleConnector 1/2NPT(M) x 1/2"Tube	316 SS Tubing	1/2"	PT-61113
FemaleConnector 1/2NPT(F) x 1/2"Tube	316 SS Tubing	1/2"	PT-61113
PRESSURE TRANSMITTER 1/2" NPT(F), PIT-RU600105		1/2"	PT-61113
Male Connector 3/4" NPT(M) x 1/2" T	316 SS Tubing	3/4"x1/2"	PT-61113
FemaleConnector 1/2NPT(F) x 1/2"Tube	316 SS Tubing	1/2"	PT-61113
Female Sub 1/2"NPT(F) x 1/2"Tube	316 SS Tubing	1/2"	PT-61113
PRESSURE GAUGE 1/2" NPT(M)		1/2"	PT-61113
2-Way-Manifold	316 SS Tubing	1/2"	PT-61113
PLUG, HEX HEAD, 1/2" NPT (M), ASME B16.11	316 SS Tubing	1/2"	PT-61113
MaleConnector 1/2NPT(M) x 1/2"Tube	316 SS Tubing	1/2"	PT-61113
Union_TEE_1/4" to 1"	316 SS Tubing	1/2"	PT-61113
TUBING, 1/2" , 0.065" THK , LENGTH 5'-5 9/18" , ASTM A269 , SEAMLESS	316 SS Tubing	1/2"	PT-61121

2-Way-Manifold	316 SS Tubing	1/2"	PT-61121
PLUG, HEX HEAD, 1/2" NPT (M), ASME B16.11	316 SS Tubing	1/2"	PT-61121
MaleConnector 1/2NPT(M) x 1/2"Tube	316 SS Tubing	1/2"	PT-61121
FemaleConnector 1/2NPT(F) x 1/2"Tube	316 SS Tubing	1/2"	PT-61121
Female Sub 1/2"NPT(F) x 1/2"Tube		1/2"	PT-61121
PRESSURE GAUGE 1/2" NPT(M)	316 SS Tubing	1/2"	PT-61121
2-Way-Manifold	316 SS Tubing	1/2"	PT-61121
PLUG, HEX HEAD, 1/2" NPT (M), ASME B16.11	316 SS Tubing	1/2"	PT-61121
MaleStub1/2NPT(M) x 1/2"Tube	316 SS Tubing	1/2"	PT-61121
MaleConnector 1/2NPT(M) x 1/2"Tube	316 SS Tubing	1/2"	PT-61121
FemaleConnector 1/2NPT(F) x 1/2"Tube	316 SS Tubing	1/2"	PT-61121
PRESSURE TRANSMITTER 1/2" NPT(F), PIT-RU600105	316 SS Tubing	1/2"	PT-61121
Union_TEE_1/4" to 1"	316 SS Tubing	1/2"	PT-61121
Male Connector 3/4" NPT(M) x 1/2" T	316 SS Tubing	3/4"x1/2"	PT-61121
TUBING, 1/2" , 0.065" THK , LENGTH 2'-2 3/4" , ASTM A269 , SEAMLESS	316 SS Tubing	1/2"	PT-61123
2-Way-Manifold	316 SS Tubing	1/2"	PT-61123
MaleStub1/2NPT(M) x 1/2"Tube	316 SS Tubing	1/2"	PT-61123
MaleConnector 1/2NPT(M) x 1/2"Tube	316 SS Tubing	1/2"	PT-61123
FemaleConnector 1/2NPT(F) x 1/2"Tube	316 SS Tubing	1/2"	PT-61123
PRESSURE TRANSMITTER 1/2" NPT(F), PIT-RU600105		1/2"	PT-61123
Male Connector 3/4" NPT(M) x 1/2" T	316 SS Tubing	3/4"x1/2"	PT-61123
PLUG, HEX HEAD, 1/2" NPT (M), ASME B16.11	316 SS Tubing	1/2"	PT-61123
2-Way-Manifold	316 SS Tubing	1/2"	PT-61123
PLUG, HEX HEAD, 1/2" NPT (M), ASME B16.11	316 SS Tubing	1/2"	PT-61123
MaleConnector 1/2NPT(M) x 1/2"Tube	316 SS Tubing	1/2"	PT-61123
FemaleConnector 1/2NPT(F) x 1/2"Tube	316 SS Tubing	1/2"	PT-61123
Female Sub 1/2"NPT(F) x 1/2"Tube	316 SS Tubing	1/2"	PT-61123
PRESSURE GAUGE 1/2" NPT(M)		1/2"	PT-61123
Union_TEE_1/4" to 1"	316 SS Tubing	1/2"	PT-61123
TUBING, 1/2" , 0.065" THK , LENGTH 6'-5 5/16" , ASTM A269 , SEAMLESS	316 SS Tubing	1/2"	PT-61131
2-Way-Manifold	316 SS Tubing	1/2"	PT-61131
MaleStub1/2NPT(M) x 1/2"Tube	316 SS Tubing	1/2"	PT-61131
MaleConnector 1/2NPT(M) x 1/2"Tube	316 SS Tubing	1/2"	PT-61131
PRESSURE TRANSMITTER 1/2" NPT(F), PIT-RU600105		1/2"	PT-61131
Male Connector 3/4" NPT(M) x 1/2" T	316 SS Tubing	3/4"x1/2"	PT-61131
FemaleConnector 1/2NPT(F) x 1/2"Tube	316 SS Tubing	1/2"	PT-61131
2-Way-Manifold	316 SS Tubing	1/2"	PT-61131
MaleConnector 1/2NPT(M) x 1/2"Tube	316 SS Tubing	1/2"	PT-61131
FemaleConnector 1/2NPT(F) x 1/2"Tube	316 SS Tubing	1/2"	PT-61131
Female Sub 1/2"NPT(F) x 1/2"Tube	316 SS Tubing	1/2"	PT-61131

PRESSURE GAUGE 1/2" NPT(M)	316 SS Tubing	1/2"	PT-61131
Union_TEE_1/4" to 1"	316 SS Tubing	1/2"	PT-61131
PLUG, HEX HEAD, 1/2" NPT (M), ASME B16.11	316 SS Tubing	1/2"	PT-61131
PLUG, HEX HEAD, 1/2" NPT (M), ASME B16.11	316 SS Tubing	1/2"	PT-61131
TUBING, 1/2" , 0.065" THK , LENGTH 5'-9 1/8" , ASTM A269 , SEAMLESS	316 SS Tubing	1/2"	PT-61132
2-Way-Manifold	316 SS Tubing	1/2"	PT-61132
MaleStub1/2NPT(M) x 1/2"Tube	316 SS Tubing	1/2"	PT-61132
MaleConnector 1/2NPT(M) x 1/2"Tube	316 SS Tubing	1/2"	PT-61132
PRESSURE TRANSMITTER 1/2" NPT(F), PIT-RU600105		1/2"	PT-61132
FemaleConnector 1/2NPT(F) x 1/2"Tube	316 SS Tubing	1/2"	PT-61132
PLUG, HEX HEAD, 1/2" NPT (M), ASME B16.11	316 SS Tubing	1/2"	PT-61132
Male Connector 3/4" NPT(M) x 1/2" T	316 SS Tubing	3/4"x1/2"	PT-61132
2-Way-Manifold	316 SS Tubing	1/2"	PT-61132
MaleConnector 1/2NPT(M) x 1/2"Tube	316 SS Tubing	1/2"	PT-61132
FemaleConnector 1/2NPT(F) x 1/2"Tube	316 SS Tubing	1/2"	PT-61132
PLUG, HEX HEAD, 1/2" NPT (M), ASME B16.11	316 SS Tubing	1/2"	PT-61132
Female Sub 1/2"NPT(F) x 1/2"Tube	316 SS Tubing	1/2"	PT-61132
4" (100 MM) PRESSURE GAUGE 1/2" NPT(M)		1/2"	PT-61132
Union_TEE_1/4" to 1"	316 SS Tubing	1/2"	PT-61132
MaleConnector 1/2NPT(M) x 1/2"Tube	316 SS Tubing	1/2"	PT-61133
TUBING, 1/2" , 0.065" THK , LENGTH 1'-4 7/16" , ASTM A269 , SEAMLESS	316 SS Tubing	1/2"	PT-61133
2-Way-Manifold	316 SS Tubing	1/2"	PT-61133
PLUG, HEX HEAD, 1/2" NPT (M), ASME B16.11	316 SS Tubing	1/2"	PT-61133
MaleConnector 1/2NPT(M) x 1/2"Tube	316 SS Tubing	1/2"	PT-61133
FemaleConnector 1/2NPT(F) x 1/2"Tube	316 SS Tubing	1/2"	PT-61133
MaleStub1/2NPT(M) x 1/2"Tube	316 SS Tubing	1/2"	PT-61133
PRESSURE TRANSMITTER 1/2" NPT(F), PIT-RU600105		1/2"	PT-61133
TUBING, 1/2" , 0.065" THK , LENGTH 2'-9 5/8" , ASTM A269 , SEAMLESS	316 SS Tubing	1/2"	PT-61134
MaleConnector 1/2NPT(M) x 1/2"Tube	316 SS Tubing	1/2"	PT-61134
2-Way-Manifold	316 SS Tubing	1/2"	PT-61134
MaleStub1/2NPT(M) x 1/2"Tube	316 SS Tubing	1/2"	PT-61134
MaleConnector 1/2NPT(M) x 1/2"Tube	316 SS Tubing	1/2"	PT-61134
FemaleConnector 1/2NPT(F) x 1/2"Tube	316 SS Tubing	1/2"	PT-61134
PRESSURE TRANSMITTER 1/2" NPT(F), PIT-RU600105		1/2"	PT-61134
PLUG, HEX HEAD, 1/2" NPT (M), ASME B16.11	316 SS Tubing	1/2"	PT-61134
TUBING, 1/2" , 0.065" THK , LENGTH 2'-2" , ASTM A269 , SEAMLESS	316 SS Tubing	1/2"	PT-61141
2-Way-Manifold	316 SS Tubing	1/2"	PT-61141
PLUG, HEX HEAD, 1/2" NPT (M), ASME B16.11	316 SS Tubing	1/2"	PT-61141
MaleStub1/2NPT(M) x 1/2"Tube	316 SS Tubing	1/2"	PT-61141
MaleConnector 1/2NPT(M) x 1/2"Tube	316 SS Tubing	1/2"	PT-61141

BILL OF MATERIALS			
PIPE			
ID	QTY	LONG DESCRIPTION (FAMILY)	
1	28'-8 3/4"	TUBING, ASTM A269, SEAMLESS -- 316SS	0.065" THK
FITTINGS			
ID	QTY	LONG DESCRIPTION (FAMILY)	
2	2	STUB 1/4NPT(M) x 1/2"Tube	
3	2	MaleConnector 1/2 NPT(M) x 1/2"Tube	
4	32	BEND 90 5R, TUBING, ASTM A269, 316SS	
5	9	BEND 45 5R, TUBING, ASTM A269, 316SS	
6	2	Union ELB, Tubing, 1/4" to 1"	
7	2	Male Connector 3/4" NPT(M) x 1/2" T	
8	1	Union_TEE_1/4" to 1"	
VALVES			
ID	QTY	LONG DESCRIPTION (FAMILY)	
9	1	Regulator-1/4"	
10	2	Solenoid, 1/4" to 1/2"	
11	1	Direction Vale. 1/2"	
PIPE SUPPORTS			
ID	QTY	LONG DESCRIPTION (FAMILY)	
12	10	U-clamp	

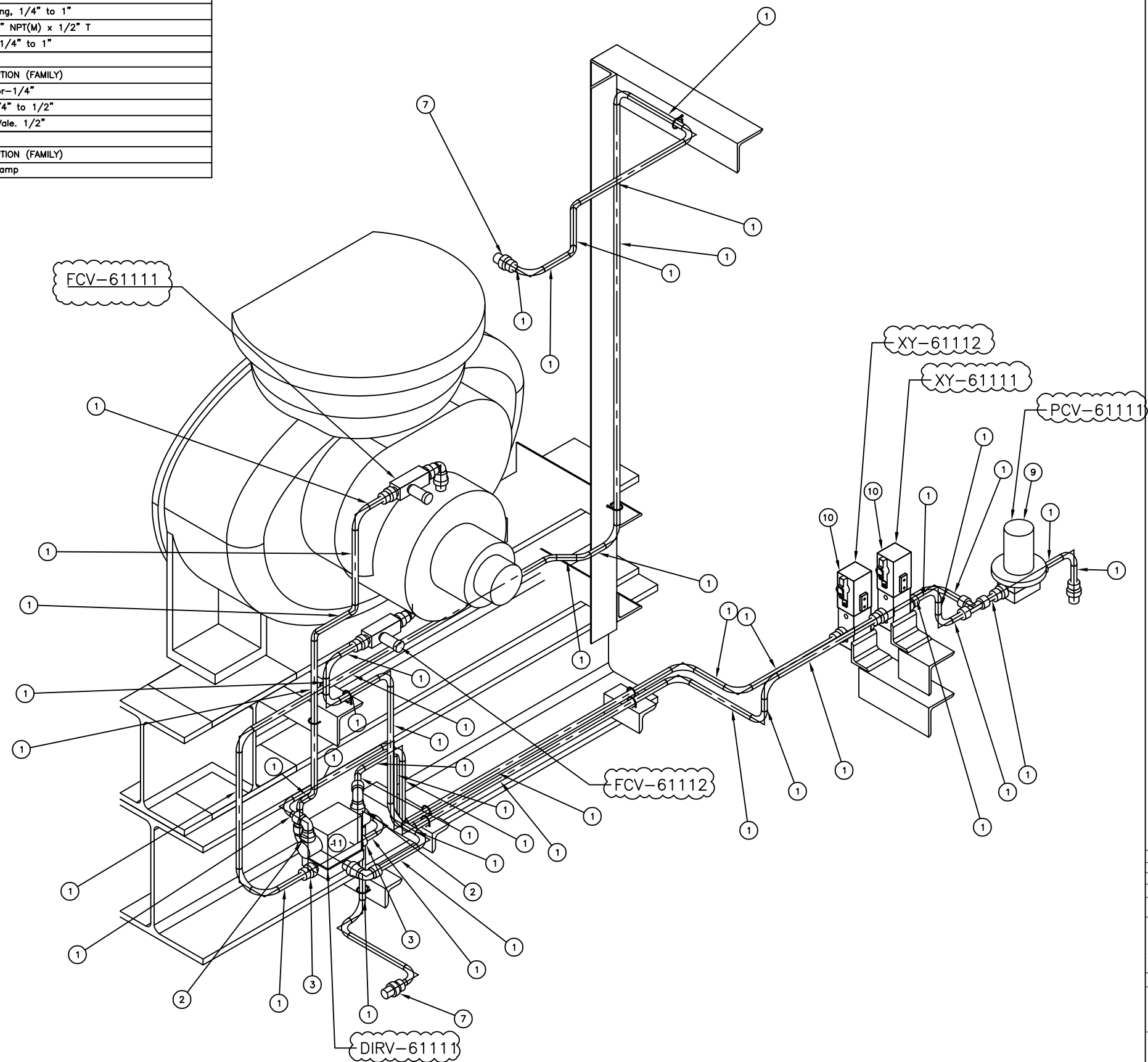



Code1	<input type="checkbox"/> No Comment/ Approved (Applicable Only for "FOR REVIEW" and "For Approval" Documents) No comment and the document are released for Manufacturing				
Code2	<input type="checkbox"/> No Comment/ Approved with Note(s) Vendor/Sub-Contractor shall correct, revise and resubmit the document. The document is released for Manufacturing if changes incorporated.				
Code3	<input type="checkbox"/> Commented Vendor/Sub-Contractor shall correct, revise and resubmit the document by the date specified. The document shall be revised under the Status of "R: Revised Issue". All corrected documents shall be resubmitted before starting the Manufacturing Process				
Code4	<input type="checkbox"/> Not Accepted (Rejected) Vendor/Sub-Contractor shall re-work/re-design/re-specify the contents of the document according to the comments/reasons for rejection. All corrected documents shall be resubmitted before starting the manufacturing. Vendor Sub-Contractor shall not proceed with subsequent works of Material Supply or Manufacturing until receiving Code1/Code2 or No Code from PURCHASER. Vendor/Sub-Contractor shall resubmit the document with the same revision within 6 working days after receiving comments				
No Code	<input type="checkbox"/> No Code (Only for "For Information" Documents and "As Built DWGs") Document has been submitted for PURCHASER's Information (FI). Consistency, completeness and correctness of document content is in Vendor/Sub-Contractor's responsibility.				
The above checking result by EIED shall in no way relieve Vendor of any liability, obligation and responsibility out of the purchase order and the mutual agreement in writing					
DATE :					
DEPT:					
Signature :					
CV	PI	EL	IN	ME	MA
ST	BU	PR	SA	HV	TL

01	05-FEB-2026	IF1	D.SH	F.T	A.M
00	09-DEC-2025	IF1	D.SH	F.T	A.M
REV.	DATE (DD.MM.YY)	Purpose of Issue	Prepared	Checked	Approved
		Gachsaran Polymer Industries Company HDPE Plant			
PO No.: GPIC-PT-MA-PO-000-3029					SCALE: 1:1
DRAWING TITLE: Instruments Hookup Diagram and MTO					
DRAWING NO. VD-GPIC-MA-3029-3029-0051				REV. SHEET NO. SIZE 01 9 of 39 A3	

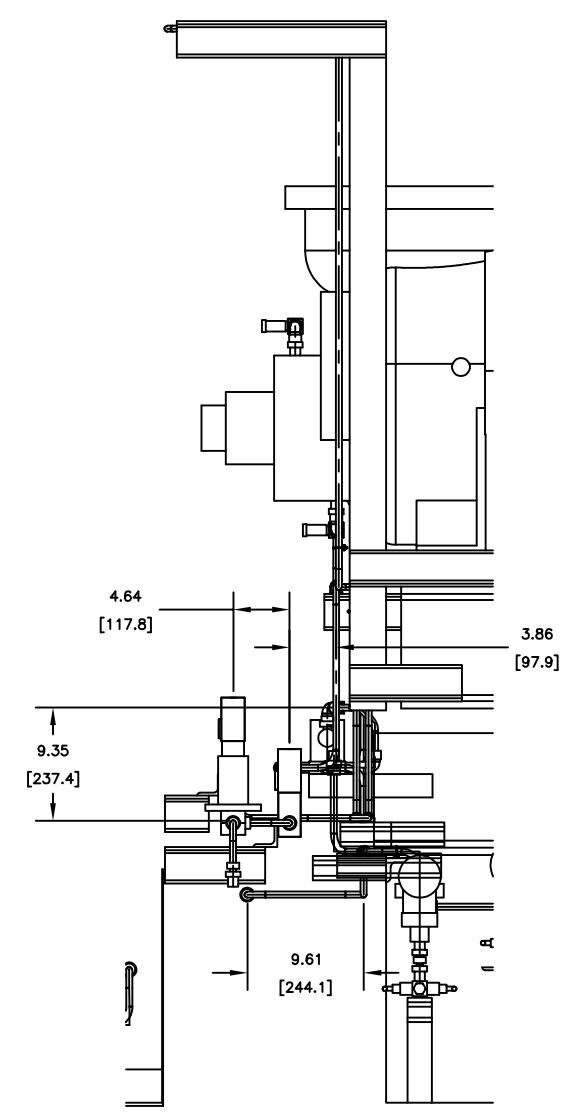
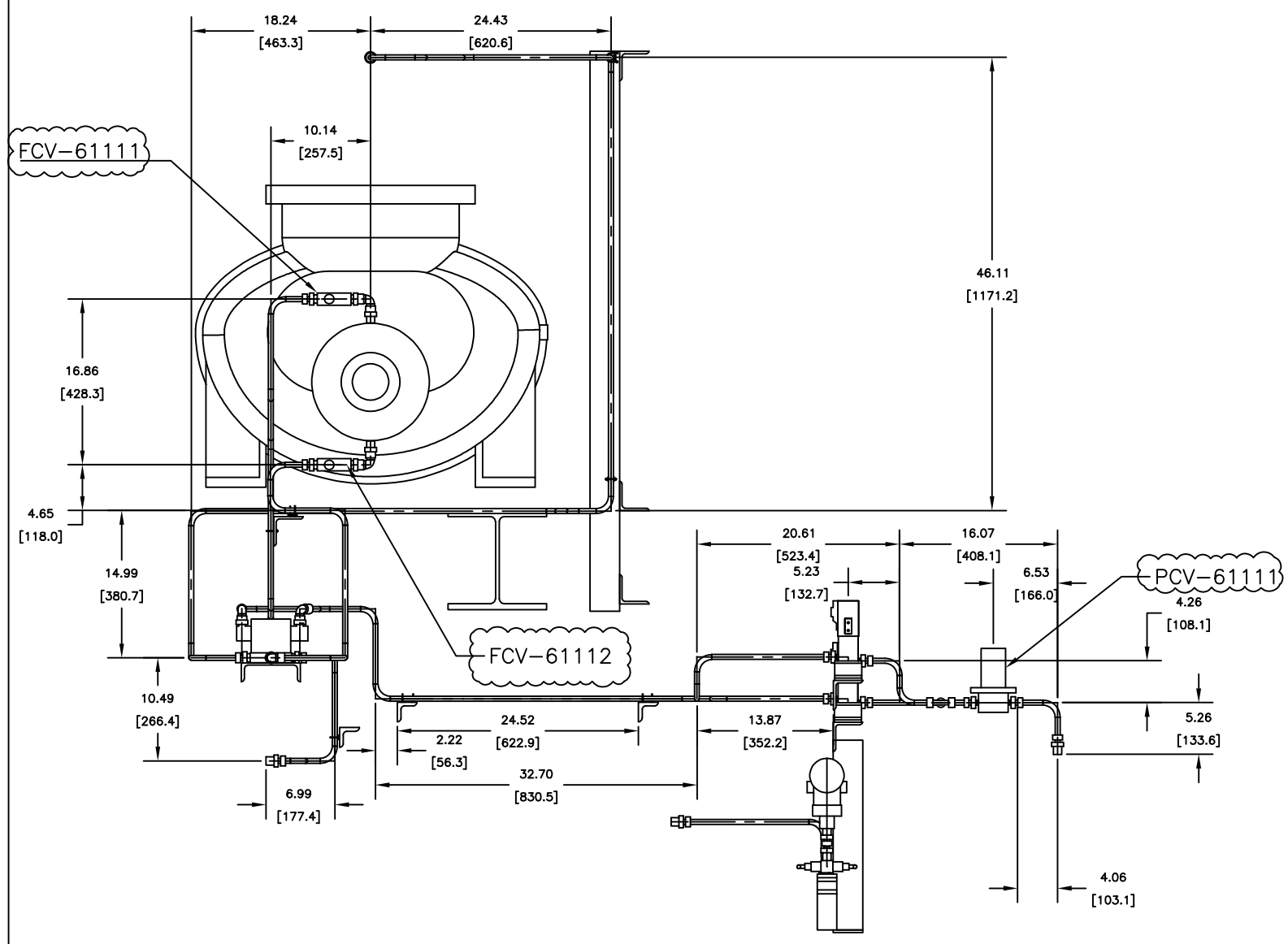
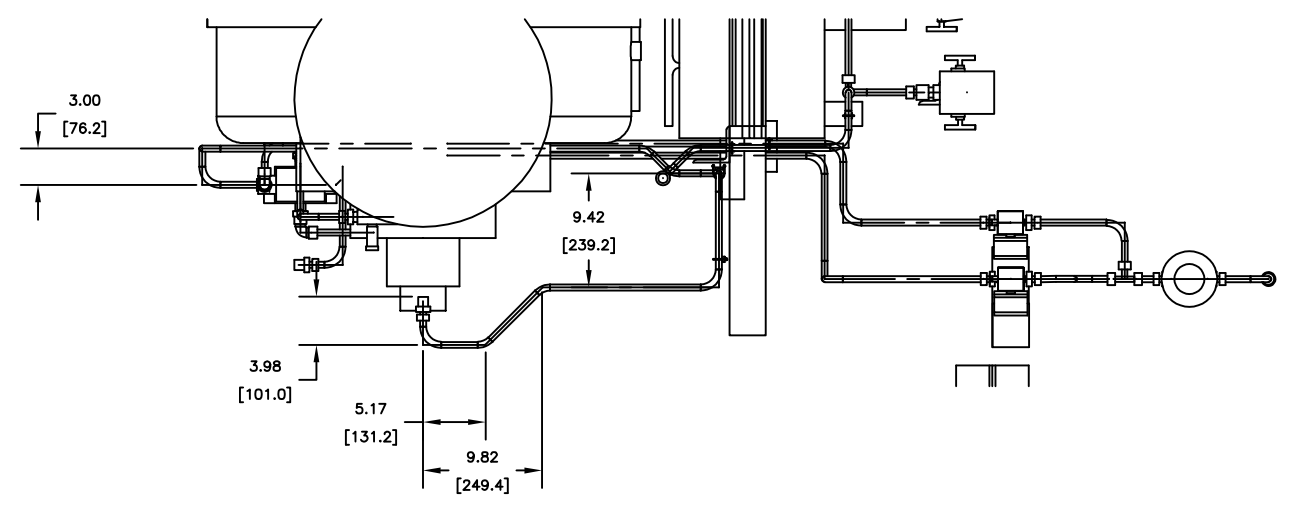
FOR MTO, REFER TO SHEET 1



Code1	<input type="checkbox"/> No Comment/ Approved (Applicable Only for "FOR REVIEW" and "For Approval" Documents) No comment and the document are released for Manufacturing				
Code2	<input type="checkbox"/> No Comment/ Approved with Note(s) Vendor/Sub-Contractor shall correct, revise and resubmit the document. The document is released for Manufacturing if changes incorporated.				
Code3	<input type="checkbox"/> Commented Vendor/Sub-Contractor shall correct, revise and resubmit the document by the date specified. The document shall be revised under the Status of "R: Revised Issue". All corrected documents shall be resubmitted before starting the Manufacturing Process				
Code4	<input type="checkbox"/> Not Accepted (Rejected) Vendor/Sub-Contractor shall re-work/re-design/re-specify the contents of the document according to the comments/reasons for rejection. All corrected documents shall be resubmitted before starting the manufacturing. Vendor/Sub-Contractor shall not proceed with subsequent works of Material Supply or Manufacturing until receiving Code1/Code2 or No Code from PURCHASER. Vendor/Sub-Contractor shall resubmit the document with the same revision within 6 working days after receiving comments				
No Code	<input type="checkbox"/> No Code (Only for "For Information" Documents and "As Built DWG") Document has been submitted for PURCHASER'S information (FI). Consistency, completeness and correctness of document content is in Vendor/Sub-Contractor's responsibility.				
The above checking result by EIED shall in no way relieve Vendor of any liability, obligation and responsibility out of the purchase order and the mutual agreement in writing					
					
DATE: _____					
DEPT: _____					
Signature: _____					
CV	PI	EL	IN	ME	MA
ST	BU	PR	SA	HV	TL

01	05-FEB-2026	IF1	D.SH	F.T	A.M
00	09-DEC-2025	IF1	D.SH	F.T	A.M
REV.	DATE (DD-MMM-YY)	Purpose of Issue	Prepared	Checked	Approved
		Gachsan Polymer Industries Company HOPE Plant			
PO No.: GPIC-PT-MA-PO-000-3029					SCALE: 1:1
DRAWING TITLE: Instruments Hookup Diagram and MTO					
DRAWING NO. VD-GPIC-MA-3029-3029-0051			REV.	SHEET NO.	SIZE
			01	10 of 39	A3

BILL OF MATERIALS		
PIPE		
ID	QTY	LONG DESCRIPTION (FAMILY)
1	26'-5 3/16"	TUBING, ASTM A269, SEAMLESS -- 316SS 0.065" THK
FITTINGS		
ID	QTY	LONG DESCRIPTION (FAMILY)
2	1	Male Connector, 316SS. NPT(M) x Tube
3	2	MaleStub 1/4" NPT(M) x 1/2" Tube
4	2	Male Connector 1/2" NPT(M) x 1/2" T
5	32	BEND 90 5R, TUBING, ASTM A269, 316SS
6	9	BEND 45 5R, TUBING, ASTM A269, 316SS
7	2	Union ELB, Tubing, 1/4" to 1"
8	2	Male Connector 3/4" NPT(M) x 1/2" T
9	1	Union_TEE_1/4" to 1"
VALVES		
ID	QTY	LONG DESCRIPTION (FAMILY)
10	1	Regulator-1/4" NPT(F)
11	2	Solenoid, 1/4" NPT(F)
12	1	Direction Vale. 1/2"
PIPE SUPPORTS		
ID	QTY	LONG DESCRIPTION (FAMILY)
13	10	U-clamp

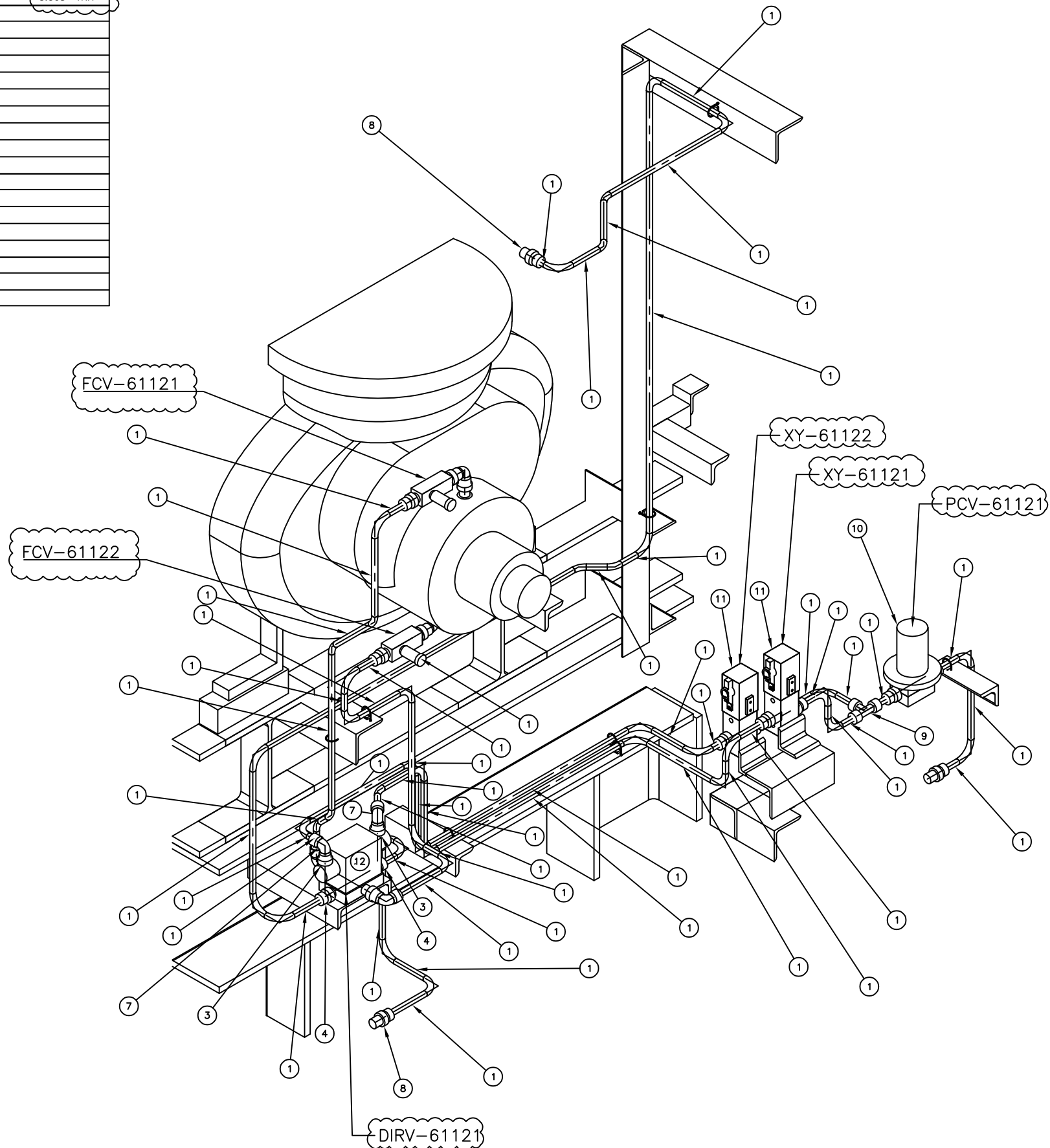

Code1	<input type="checkbox"/> No Comment/ Approved (Applicable Only for "FOR REVIEW" and "For Approval" Documents) No comment and the document are released for Manufacturing				
Code2	<input type="checkbox"/> No Comment/ Approved with Note(s) Vendor/Sub-Contractor shall correct, revise and resubmit the document. The document is released for Manufacturing if changes incorporated.				
Code3	<input type="checkbox"/> Commented Vendor/Sub-Contractor shall correct, revise and resubmit the document by the date specified. The document shall be released under the Status of "It: Revised Issue". All corrected documents shall be resubmitted before starting the Manufacturing Process				
Code4	<input type="checkbox"/> Not Accepted (Rejected) Vendor/Sub-Contractor shall re-work/re-design/re-specify the contents of the document according to the comments/reasons for rejection. All corrected documents shall be resubmitted before starting the manufacturing. Vendor Sub-Contractor shall not proceed with subsequent works of Material Supply or Manufacturing until receiving Code1/Code2 or No Code from PURCHASER. Vendor/Sub-Contractor shall resubmit the document with the same revision within 6 working days after receiving comments				
No Code	<input type="checkbox"/> No Code (Only for "For Information" Documents and "As Built DWGs") Document has been submitted for PURCHASER'S Information (FI). Consistency, completeness and correctness of document content is in Vendor/Sub-Contractor's responsibility.				
The above checking result by EIED shall in no way relieve Vendor of any liability, obligation and responsibility out of the purchase order and the mutual agreement in writing					
DATE : _____ DEPT: _____ Signature : _____					
CV	PI	EL	IN	ME	MA
ST	BU	PR	SA	HV	TL

01	08-FEB-2026	IF1	D.SH	F.T	A.M
00	09-DEC-2025	IF1	D.SH	F.T	A.M
REV.	DATE (DD-MMM-YY)	Purpose of Issue	Prepared	Checked	Approved
		Gacharan Polymer Industries Company HOPE Plant			
PO No.: GPIC-PT-MA-PO-000-3029					
DRAWING TITLE: Instruments Hookup Diagram and MTO					
DRAWING NO. VD-GPIC-MA-3029-3029-0051			REV.	SHEET NO.	SIZE
			01	11 of 39	A3

FOR MTO, REFER TO SHEET 1

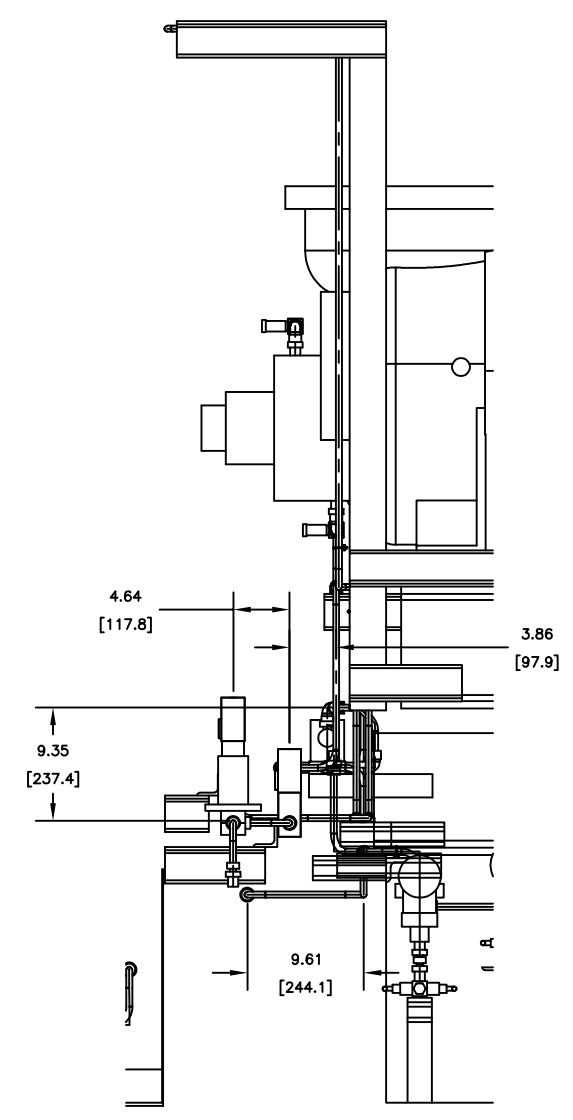
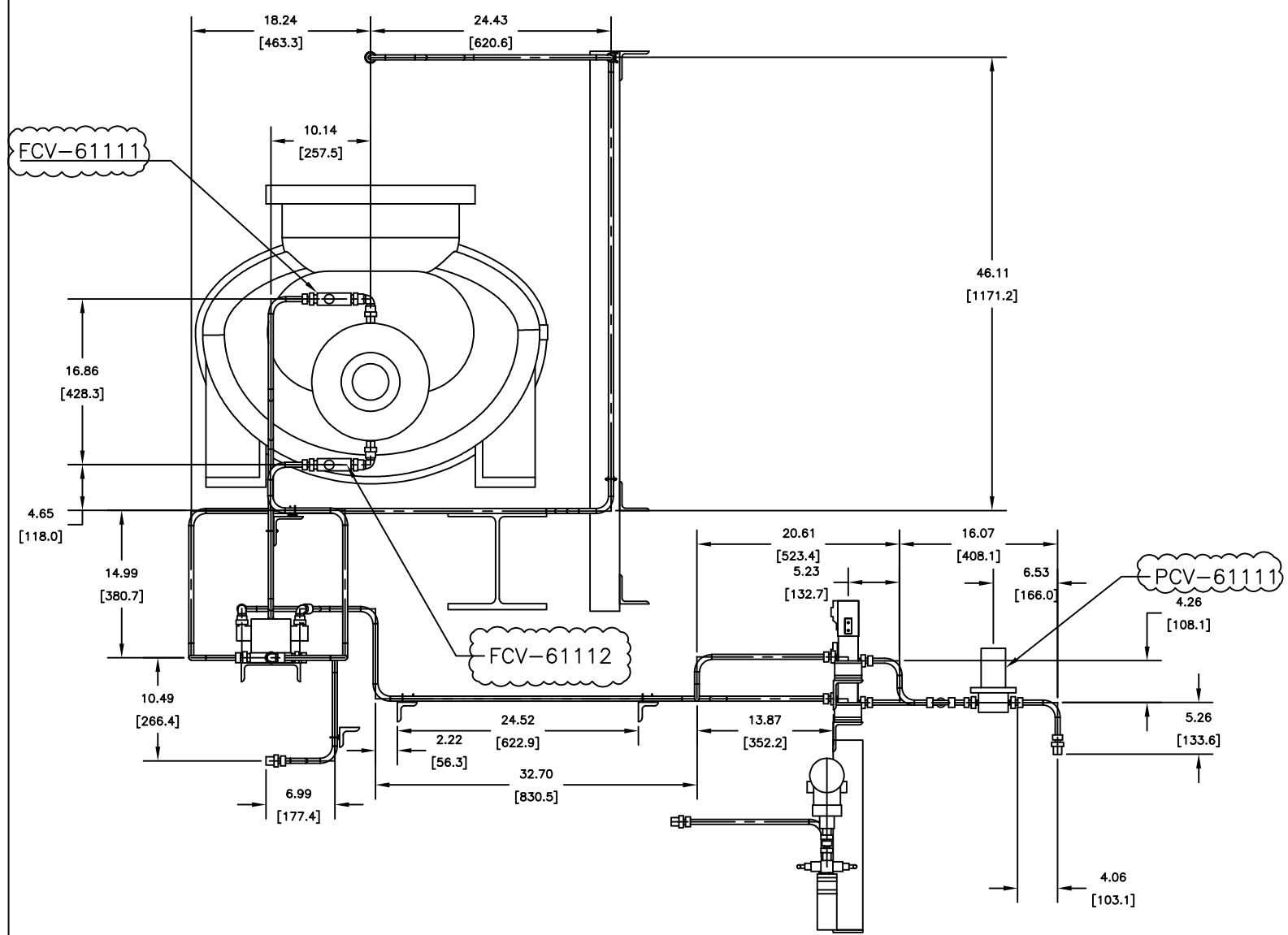
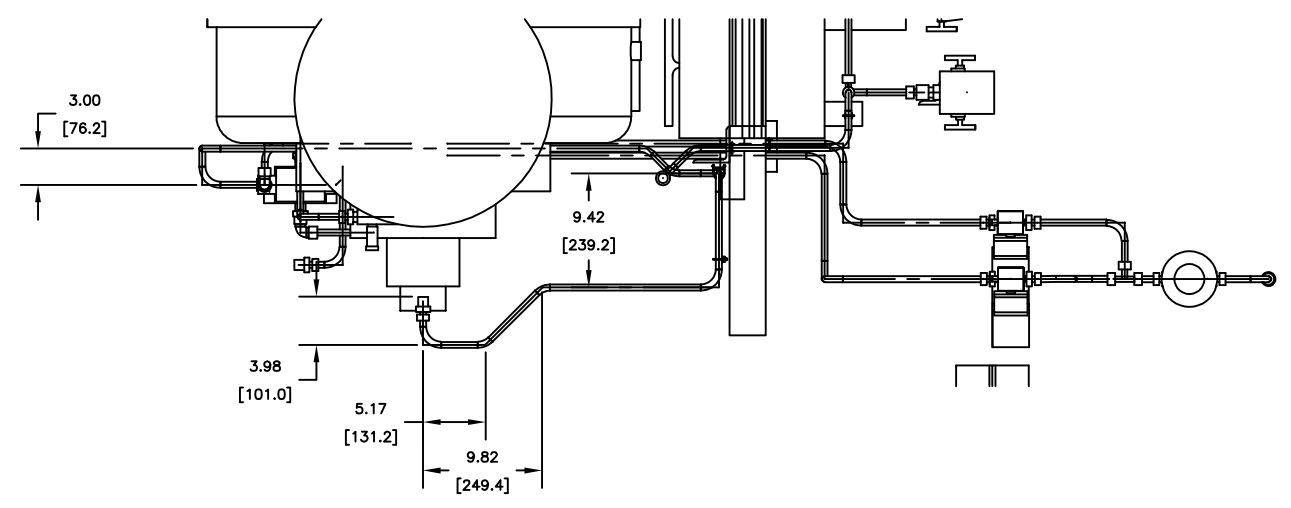





Code1	<input type="checkbox"/> No Comment/ Approved (Applicable Only for "FOR REVIEW" and "For Approval" Documents) No comment and the document are released for Manufacturing
Code2	<input type="checkbox"/> No Comment/ Approved with Note(s) Vendor/Sub-Contractor shall correct, revise and resubmit the document, the document is released for Manufacturing if changes incorporated.
Code3	<input type="checkbox"/> Commented Vendor/Sub-Contractor shall correct, revise and resubmit the document by the date specified. The document shall be revised under the Status of "Revised Issue". All corrected documents shall be resubmitted before starting the Manufacturing Process
Code4	<input type="checkbox"/> Not Accepted (Rejected) Vendor/Sub-Contractor shall re-work/re-design/re-specify the contents of the document according to the comments/reasons for rejection. All corrected documents shall be resubmitted before starting the manufacturing. Vendor/Sub-Contractor shall not proceed with subsequent works of Material Supply or Manufacturing until receiving Code1/Code2 or No Code from PURCHASER. Vendor/Sub-Contractor shall resubmit the document with the same revision within 6 working days after receiving comments
No Code	<input type="checkbox"/> No Code (Only for "For Information" Documents and "As Built DWGs") Document has been submitted for PURCHASER'S information (FI). Consistency, completeness and correctness of document content is in Vendor/Sub-Contractor's responsibility.

The above checking result by EIED shall in no way relieve Vendor of any liability, obligation and responsibility out of the purchase order and the mutual agreement in writing

DATE :					
DEPT :					
Signature :					
CV	FI	EL	IN	ME	MA
ST	BU	PR	SA	HV	TL

01	08-FEB-2026	IF1	D.SH	F.T	A.M
00	08-DEC-2025	IF1	D.SH	F.T	A.M
REV.	DATE (DD-MMM-YY)	Purpose of Issue	Prepared	Checked	Approved



Gachsaran Polymer Industries Company
HDPE Plant



PO No.: GPIC-PT-MA-PO-000-3029 SCALE: 1:1

DRAWING TITLE:
Instruments Hookup Diagram and MTO

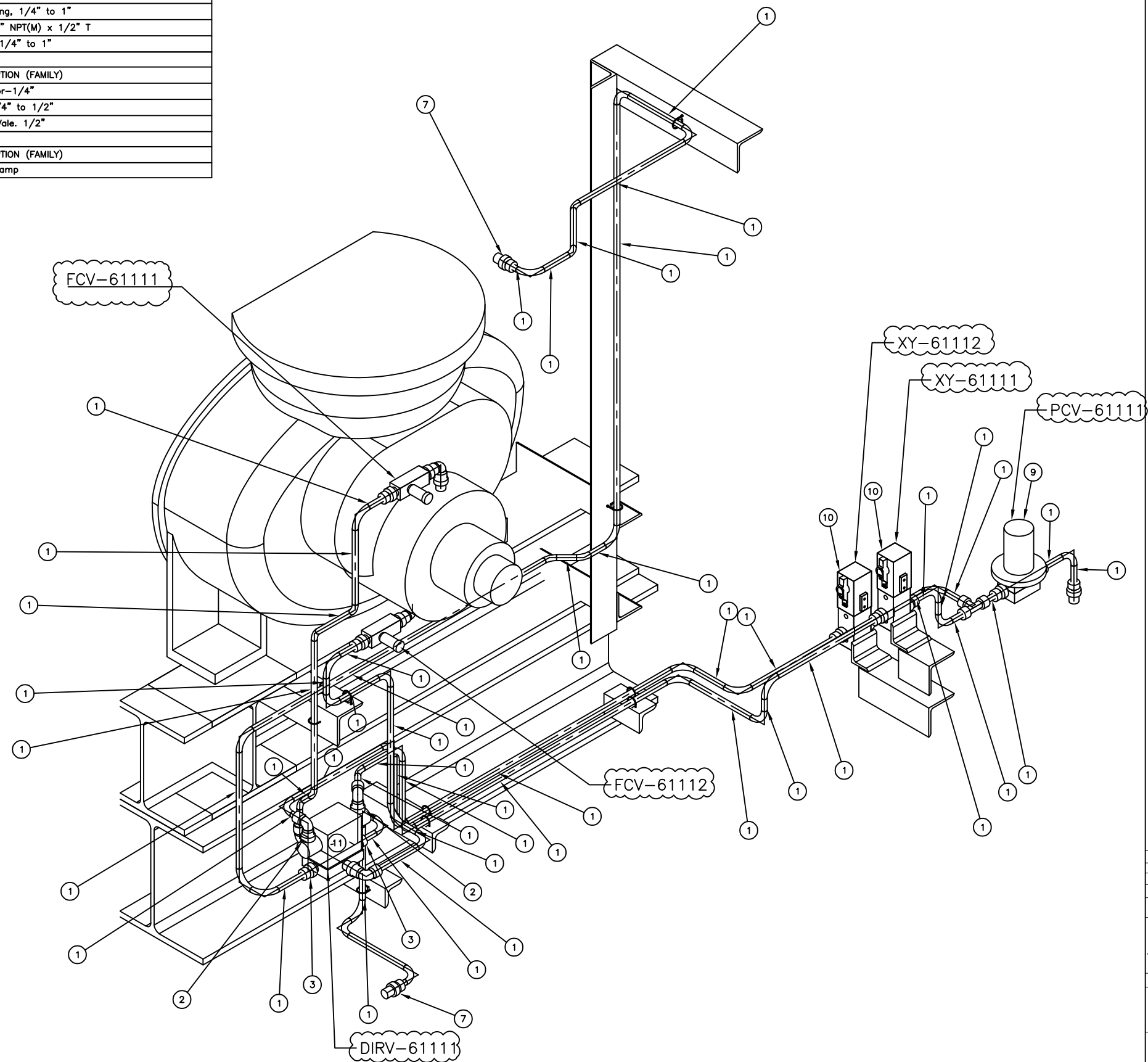
DRAWING NO.	REV.	SHEET NO.	SIZE
VD-GPIC-MA-3029-3029-0051	01	12 of 39	A3

BILL OF MATERIALS			
PIPE			
ID	QTY	LONG DESCRIPTION (FAMILY)	
1	28'-8 3/4"	TUBING, ASTM A269, SEAMLESS -- 316SS	0.065" THK
FITTINGS			
ID	QTY	LONG DESCRIPTION (FAMILY)	
2	2	STUB 1/4NPT(M) x 1/2" Tube	
3	2	MaleConnector 1/2 NPT(M) x 1/2" Tube	
4	32	BEND 90 5R, TUBING, ASTM A269, 316SS	
5	9	BEND 45 5R, TUBING, ASTM A269, 316SS	
6	2	Union ELB, Tubing, 1/4" to 1"	
7	2	Male Connector 3/4" NPT(M) x 1/2" T	
8	1	Union_TEE_1/4" to 1"	
VALVES			
ID	QTY	LONG DESCRIPTION (FAMILY)	
9	1	Regulator-1/4"	
10	2	Solenoid, 1/4" to 1/2"	
11	1	Direction Vale. 1/2"	
PIPE SUPPORTS			
ID	QTY	LONG DESCRIPTION (FAMILY)	
12	10	U-clamp	







Code1	<input type="checkbox"/> No Comment/ Approved (Applicable Only for "FOR REVIEW" and "For Approval" Documents) No comment and the document are released for Manufacturing
Code2	<input type="checkbox"/> No Comment/ Approved with Note(s) Vendor/Sub-Contractor shall correct, revise and resubmit the document. The document is released for Manufacturing if changes incorporated.
Code3	<input type="checkbox"/> Commented Vendor/Sub-Contractor shall correct, revise and resubmit the document by the date specified. The document shall be revised under the Status of "To: Revised Issue". All corrected documents shall be resubmitted before starting the Manufacturing Process
Code4	<input type="checkbox"/> Not Accepted (Rejected) Vendor/Sub-Contractor shall re-work/re-design/re-specify the contents of the document according to the comments/reasons for rejection. All corrected documents shall be resubmitted before starting the manufacturing. Vendor/Sub-Contractor shall not proceed with subsequent works of Material Supply or Manufacturing until receiving Code/Code2 or No Code from PURCHASER. Vendor/Sub-Contractor shall resubmit the document with the same revision within 6 working days after receiving comments
No Code	<input type="checkbox"/> No Code (Only for "For Information" Documents and "As Built DWGs") Document has been submitted for PURCHASER's Information (FI). Consistency, completeness and correctness of document content is in Vendor/Sub-Contractor's responsibility.

The above checking result by EIED shall in no way relieve Vendor of any liability, obligation and responsibility out of the purchase order and the mutual agreement in writing

DATE :
DEPT :
Signature :

CV	PI	EL	IN	ME	MA
ST	BU	PR	SA	HV	TL

01	08-FEB-2028	IFT	D.SH	F.T	A.M
00	08-DEC-2025	IFT	D.SH	F.T	A.M
REV.	DATE (DD-MMM-YY)	Purpose of Issue	Prepared	Checked	Approved



Gachsan Polymer Industries Company
HDPE Plant

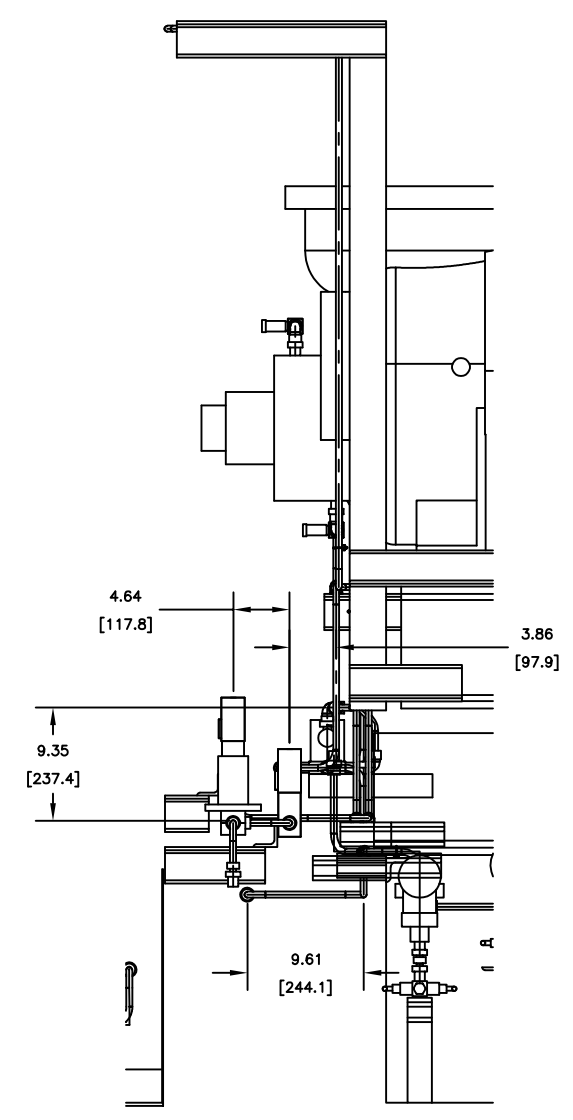
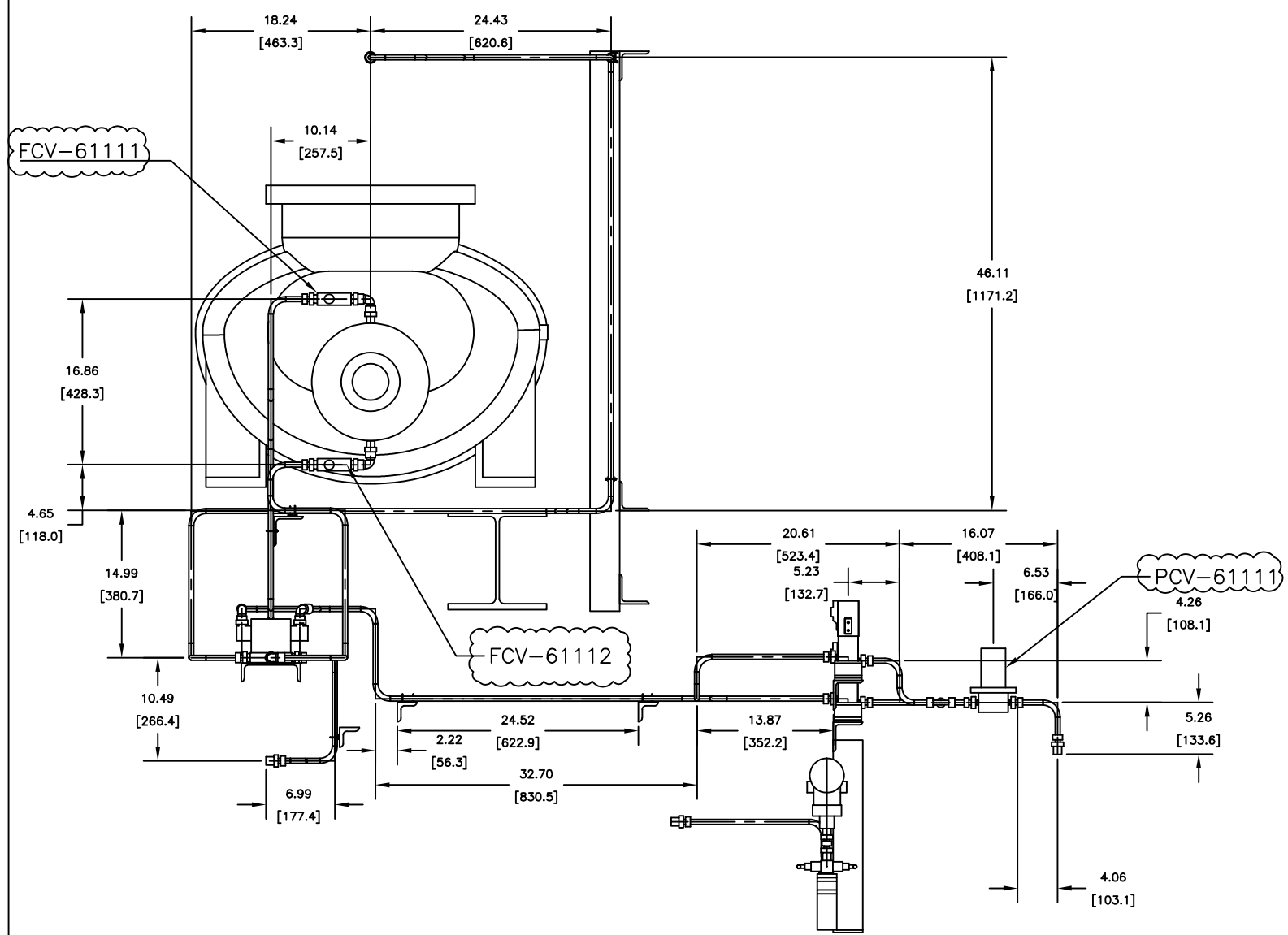
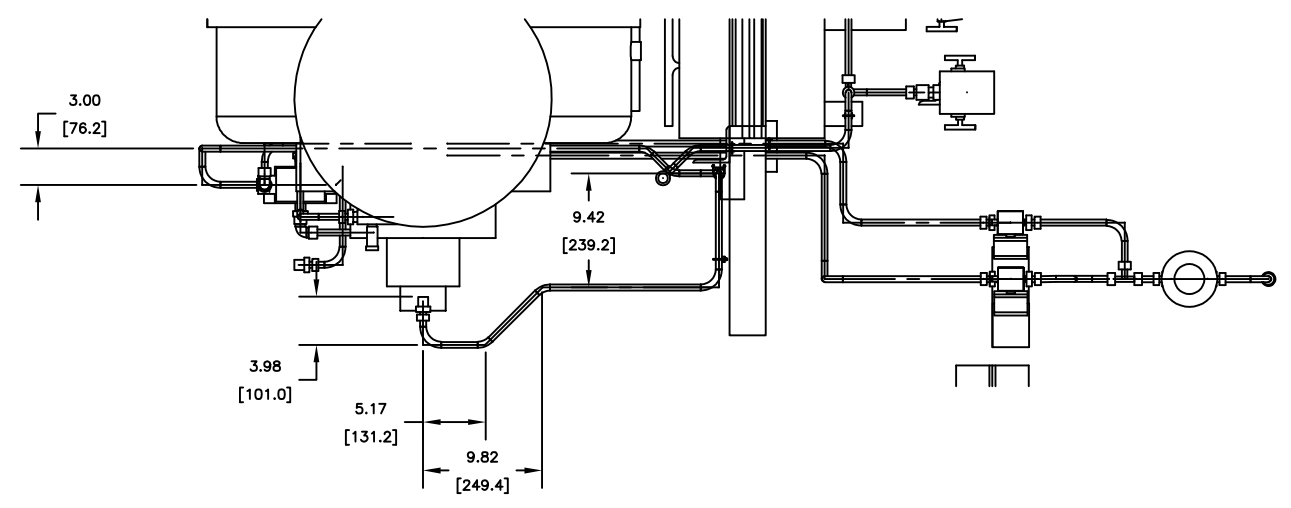

PO No.: GPIC-PT-MA-PO-000-3029 SCALE: 1:1
DRAWING TITLE:
Instruments Hookup Diagram and MTO

DRAWING NO.	REV.	SHEET NO.	SIZE
VD-GPIC-MA-3029-3029-0051	01	13 of 39	A3

FOR MTO, REFER TO SHEET 1







Code1	<input type="checkbox"/> No Comment/ Approved (Applicable Only for "FOR REVIEW" and "For Approval" Documents) No comment and the document are released for Manufacturing
Code2	<input type="checkbox"/> No Comment/ Approved with Note(s) Vendor/Sub-Contractor shall correct, revise and resubmit the document. The document is released for Manufacturing if changes incorporated.
Code3	<input type="checkbox"/> Commented Vendor/Sub-Contractor shall correct, revise and resubmit the document by the date specified. The document shall be revised under the Status of "Revised Issue". All corrected documents shall be resubmitted before starting the Manufacturing Process
Code4	<input type="checkbox"/> Not Accepted (Rejected) Vendor/Sub-Contractor shall re-work/re-design/re-specify the contents of the document according to the comments/reasons for rejection. All corrected documents shall be resubmitted before starting the manufacturing. Vendor Sub-Contractor shall not proceed with subsequent works of Material Supply or Manufacturing until reaching Code1/Code2 or No Code from PURCHASER. Vendor/Sub-Contractor shall resubmit the document with the same revision within 6 working days after receiving comments
No Code	<input type="checkbox"/> No Code (Only for "For Information" Documents and "As Built DWGs") Document has been submitted for PURCHASER'S information (FI). Consistency, completeness and correctness of document content is in Vendor/Sub-Contractor's responsibility.

The above checking result by EIED shall in no way relieve Vendor of any liability, obligation and responsibility out of the purchase order and the mutual agreement in writing.

DATE :
DEPT :
Signature :

CV	PI	EL	IN	ME	MA
ST	BU	PR	SA	HV	TL

01	08-FEB-2026	IF1	D-SH	F-T	A-M
00	09-DEC-2025	IF1	D-SH	F-T	A-M
REV.	DATE (DD.MM.YY)	Purpose of Issue	Prepared	Checked	Approved



Gachsaran Polymer Industries Company
HDPE Plant



PO No.: GPIC-PT-MA-PO-000-3029 SCALE: 1:1



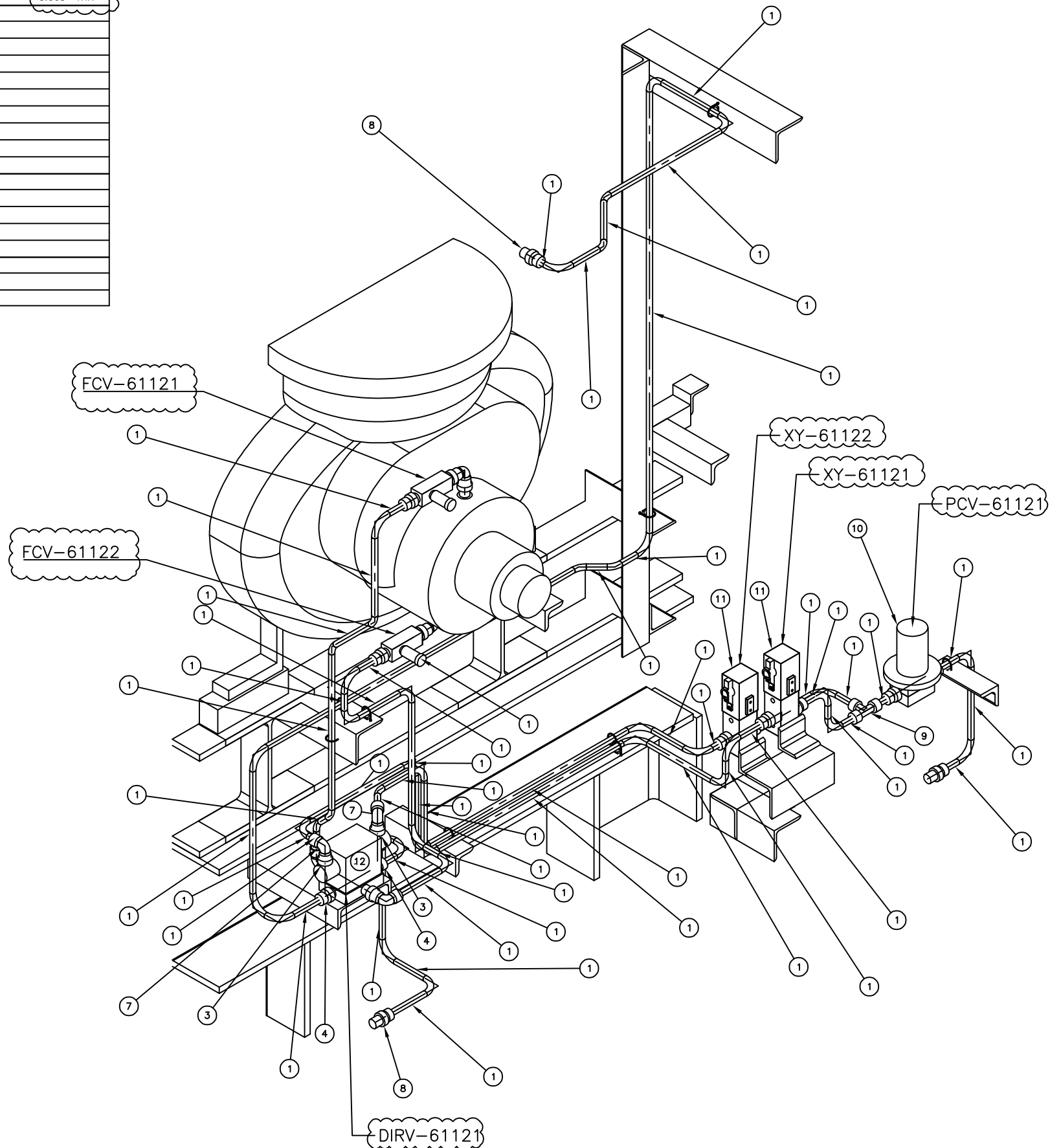

DRAWING TITLE:
Instruments Hookup Diagram and MTO

DRAWING NO.	REV.	SHEET NO.	SIZE
VD-GPIC-MA-3029-3029-0051	01	14 of 39	A3

BILL OF MATERIALS		
PIPE		
ID	QTY	LONG DESCRIPTION (FAMILY)
1	26'-5 3/16"	TUBING, ASTM A269, SEAMLESS -- 316SS 0.065" THK
FITTINGS		
ID	QTY	LONG DESCRIPTION (FAMILY)
2	1	Male Connector, 316SS. NPT(M) x Tube
3	2	MaleStub 1/4" NPT(M) x 1/2" Tube
4	2	Male Connector 1/2" NPT(M) x 1/2" T
5	32	BEND 90 5R, TUBING, ASTM A269, 316SS
6	9	BEND 45 5R, TUBING, ASTM A269, 316SS
7	2	Union ELB, Tubing, 1/4" to 1"
8	2	Male Connector 3/4" NPT(M) x 1/2" T
9	1	Union_TEE_1/4" to 1"
VALVES		
ID	QTY	LONG DESCRIPTION (FAMILY)
10	1	Regulator-1/4" NPT(F)
11	2	Solenoid, 1/4" NPT(F)
12	1	Direction Vale. 1/2"
PIPE SUPPORTS		
ID	QTY	LONG DESCRIPTION (FAMILY)
13	10	U-clamp



Code1	<input type="checkbox"/> No Comment/ Approved (Applicable Only for "FOR REVIEW" and "For Approval" Documents) No comment and the document are released for Manufacturing				
Code2	<input type="checkbox"/> No Comment/ Approved with Note(s) Vendor/Sub-Contractor shall correct, revise and resubmit the document. The document is released for Manufacturing if changes incorporated.				
Code3	<input type="checkbox"/> Commented Vendor/Sub-Contractor shall correct, revise and resubmit the document by the date specified. The document shall be revised under the Status of "Re: Revised Issue". All corrected documents shall be resubmitted before starting the Manufacturing Process				
Code4	<input type="checkbox"/> Not Accepted (Rejected) Vendor/Sub-Contractor shall re-work/re-design/re-specify the contents of the document according to the comments/reasons for rejection. All corrected documents shall be resubmitted before starting the manufacturing. Vendor Sub-Contractor shall not proceed with subsequent works of Material Supply or Manufacturing until receiving Code1/Code2 or No Code from PURCHASER. Vendor/Sub-Contractor shall resubmit the document with the same revision within 6 working days after receiving comments				
No Code	<input type="checkbox"/> No Code (Only for "For Information" Documents and "As Built DWGs") Document has been submitted for PURCHASER'S information (FI). Consistency, completeness and correctness of document content is in Vendor/Sub-Contractor's responsibility.				
The above checking result by EED shall in no way relieve Vendor of any liability, obligation and responsibility out of the purchase order and the mutual agreement in writing.					
 DATE : DEPT : Signature :					
CV	PI	EL	IN	ME	MA
ST	BU	PR	SA	HV	TL

01	08-FEB-2020	IFI	D-SH	F-T	A-M
00	06-DEC-2015	IFI	D-SH	F-T	A-M
REV.	DATE (DD-MMM-YY)	Purpose of Issue	Prepared	Checked	Approved
 		Gachsaran Polymer Industries Company HDPE Plant		 	
PO No.: GPIC-PT-MA-PO-000-3029					SCALE: 1:1
DRAWING TITLE: Instruments Hookup Diagram and MTO					
DRAWING NO. VD-GPIC-MA-3029-3029-0051			REV.	SHEET NO.	SIZE
			01	15 of 39	A3

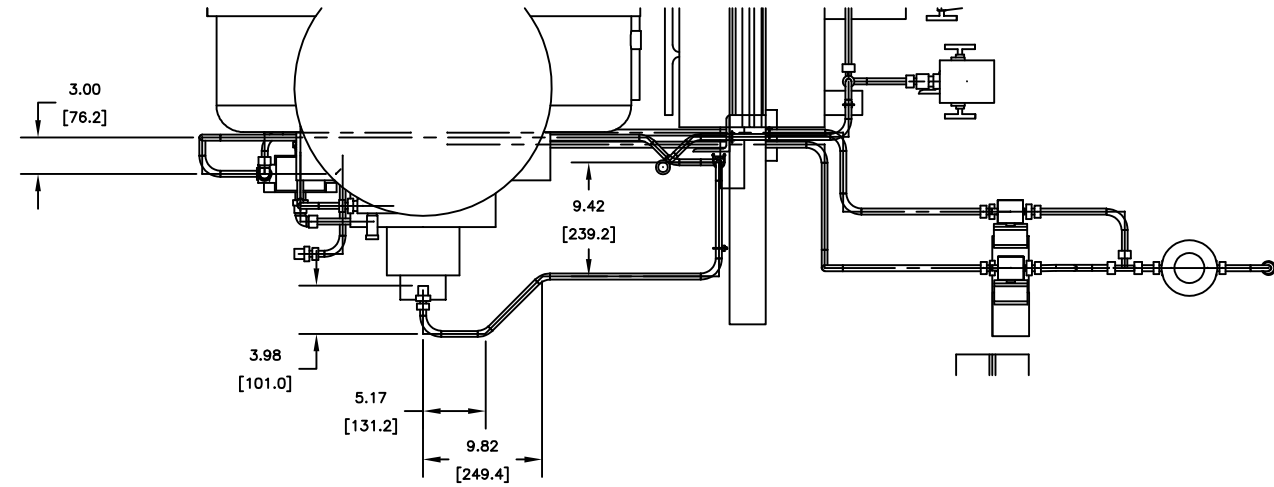

FOR MTO, REFER TO SHEET 1

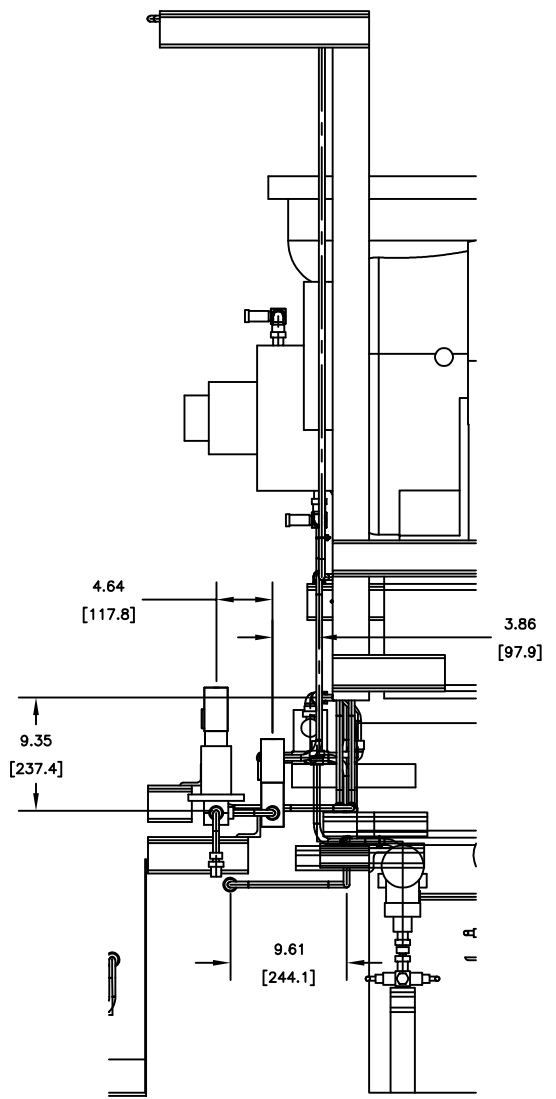
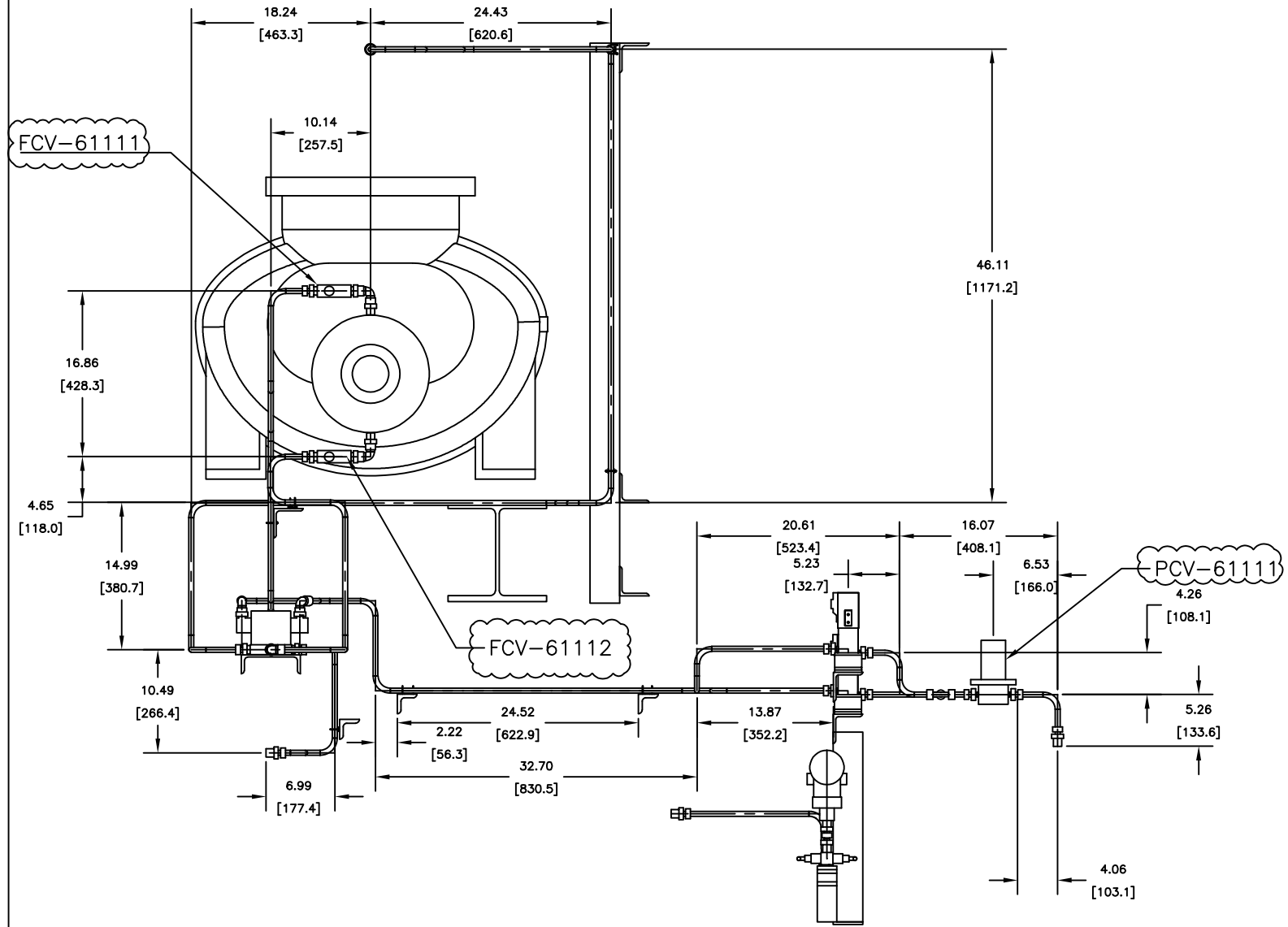





Code1	<input type="checkbox"/> No Comment/ Approved (Applicable Only for "FOR REVIEW" and "For Approval" Documents) No comment and the document are released for Manufacturing.
Code2	<input type="checkbox"/> No Comment/ Approved with Note(s) Vendor/Sub-Contractor shall correct, revise and resubmit the document. The document is released for Manufacturing if changes incorporated.
Code3	<input type="checkbox"/> Commented Vendor/Sub-Contractor shall correct, revise and resubmit the document by the date specified. The document shall be revised under the Status of "Re-Reviewed Issue". All corrected documents shall be resubmitted before starting the Manufacturing Process.
Code4	<input type="checkbox"/> Not Accepted (Rejected) Vendor/Sub-Contractor shall re-work/re-design/re-specify the contents of the document according to the comments/reasons for rejection. All corrected documents shall be resubmitted before starting the manufacturing. Vendor/Sub-Contractor shall not proceed with subsequent works of Material Supply or Manufacturing until receiving Code1/Code2 or No Code from PURCHASER. Vendor/Sub-Contractor shall resubmit the document with the same revision within 6 working days after receiving comments.
No Code	<input type="checkbox"/> No Code (Only for "For Information" Documents and "As Built DWGs") Document has been submitted for PURCHASER'S information (FI). Consistency, completeness and correctness of document content is in Vendor/Sub-Contractor's responsibility.

The above checking result by EED shall in no way relieve Vendor of any liability, obligation and responsibility out of the purchase order and the mutual agreement in writing.

DATE :
DEPT :
Signature :

CV	PI	EL	IN	ME	MA
ST	BU	PR	SA	HV	TL

01	08-FEB-2026	IF1	D.SH	F.T	A.M
00	09-DEC-2025	IF1	D.SH	F.T	A.M
REV.	DATE (DD.MM.YY)	Purpose of Issue	Prepared	Checked	Approved



Gachsan Polymer Industries Company
HDPE Plant

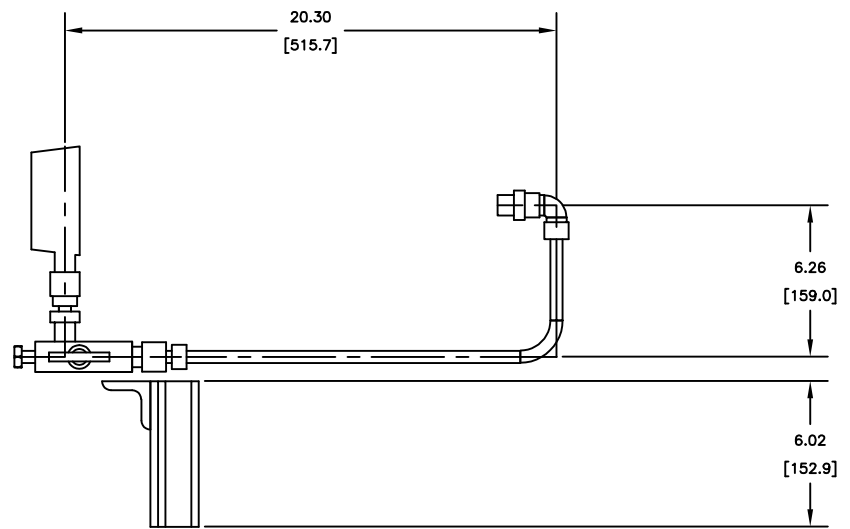
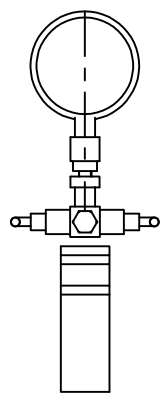
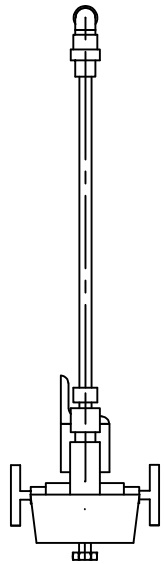

PO No.: GPIC-PT-MA-PO-000-3029 SCALE: 1:1
DRAWING TITLE:
Instruments Hookup Diagram and MTO

DRAWING NO.	REV.	SHEET NO.	SIZE
VD-GPIC-MA-3029-3029-0051	01	16 of 39	A3

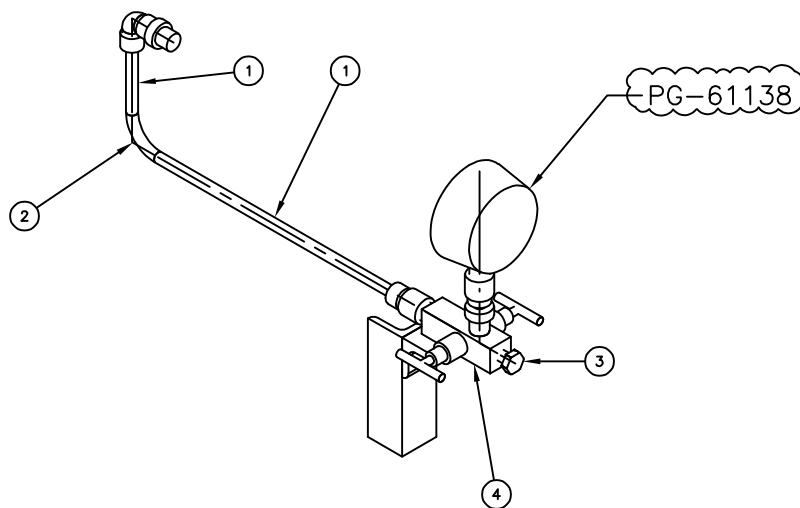

BILL OF MATERIALS				
PIPE				
ID	QTY	ND	DESCRIPTION	
1	1	1/2"	TUBING, ASTM A269, SEAMLESS - 316SS	0.065" THK
FITTINGS				
ID	QTY	ND	DESCRIPTION	
2	1	1/2"	BEND 90 5R, TUBING, ASTM A269, 316SS	
3	1	1/2"	PLUG, HEX HEAD, MPT, ASME B16.11	
VALVES				
ID	QTY	ND	DESCRIPTION	
4	1	1/2"	2-Way-Manifold	







Code1	<input type="checkbox"/> No Comment/ Approved (Applicable Only for "FOR REVIEW" and "For Approval" Documents) No comment and the document are released for Manufacturing
Code2	<input type="checkbox"/> No Comment/ Approved with Note(s) Vendor/Sub-Contractor shall correct, revise and resubmit the document. The document is released for Manufacturing if changes incorporated.
Code3	<input type="checkbox"/> Commented Vendor/Sub-Contractor shall correct, revise and resubmit the document by the date specified. The document shall be revised under the Status of "Revised Issue". All corrected documents shall be resubmitted before starting the Manufacturing Process
Code4	<input type="checkbox"/> Not Accepted (Rejected) Vendor/Sub-Contractor shall re-work/re-design/re-specify the contents of the document according to the comments/reasons for rejection. All corrected documents shall be resubmitted before starting the manufacturing. Vendor Sub-Contractor shall not proceed with subsequent works of Material Supply or Manufacturing until receiving Code/Code2 or No Code from PURCHASER. Vendor/Sub-Contractor shall resubmit the document with the same revision within 6 working days after receiving comments
No Code	<input type="checkbox"/> No Code (Only for "For Information" Documents and "As Built DWGs") Document has been submitted for PURCHASER'S information (If). Consistency, completeness and correctness of document content is in Vendor/Sub-Contractor's responsibility.

The above checking result by EIED shall in no way relieve Vendor of any liability, obligation and responsibility out of the purchase order and the mutual agreement in writing

DATE :
DEPT :
Signature :

CV	PI	EL	IN	ME	MA
ST	BU	PR	SA	HV	TL

01	08-FEB-2028	IF1	D-SH	F-T	A-M
00	09-DEC-2025	IF1	D-SH	F-T	A-M
REV.	DATE (DD-MMM-YY)	Purpose of Issue	Prepared	Checked	Approved



Gachasan Polymer Industries Company
HDPE Plant

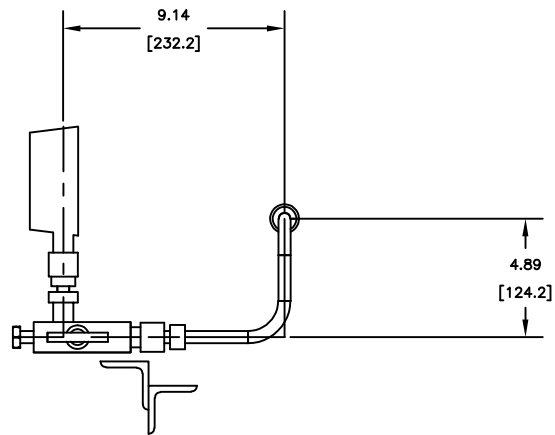
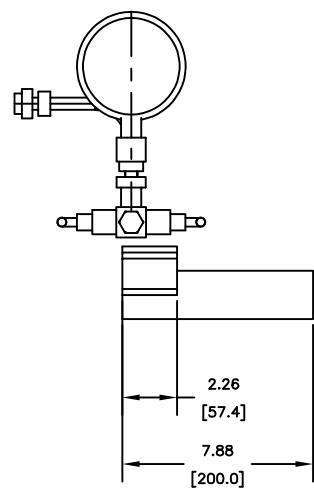
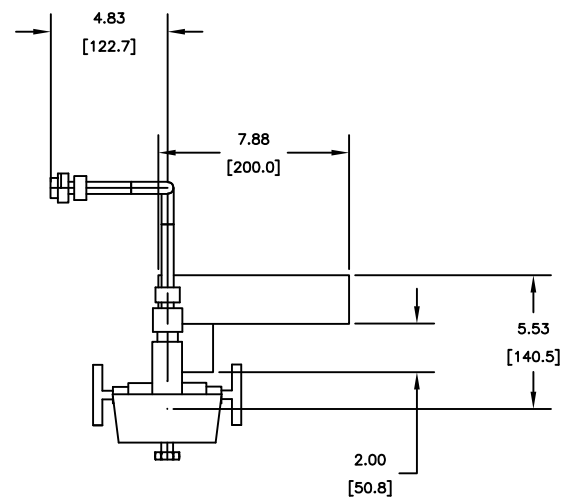

PO No.: GPIC-PT-MA-PO-000-3029 SCALE: 1:1

DRAWING TITLE:
Instruments Hookup Diagram and MTO

DRAWING NO.	REV.	SHEET NO.	SIZE
VD-GPIC-MA-3029-3029-0051	01	17 of 39	A3



BILL OF MATERIALS				
PIPE				
ID	QTY	ND	DESCRIPTION	
1	7	1/16"	TUBING, ASTM A269, SEAMLESS - 316SS	0.065" THK
FITTINGS				
ID	QTY	ND	DESCRIPTION	
2	1	1/2"xUndefined Size	MaleConnector 1/2 NPT(M) x 1/2"Tube	
3	2	1/2"	BEND 90 5R, TUBING, ASTM A269, 316SS	
4	1	1/2"	PLUG, HEX HEAD, MPT, ASME B16.11	
VALVES				
ID	QTY	ND	DESCRIPTION	
5	1	1/2"	2-Way-Manifold	

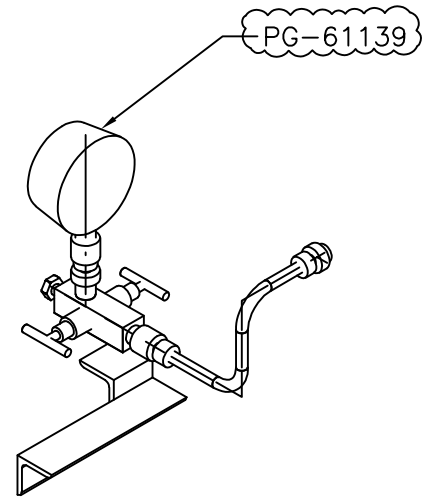

Code1 No Comment/ Approved
(Applicable Only for "FOR REVIEW" and "For Approval" Documents) No comment and the document are released for Manufacturing.

Code2 No Comment/ Approved with Note(s)
Vendor/Sub-Contractor shall correct, revise and resubmit the document. The document is released for Manufacturing if changes incorporated.

Code3 Commented
Vendor/Sub-Contractor shall correct, revise and resubmit the document by the date specified. The document shall be revised under the Status of "To Be Revised". All corrected documents shall be resubmitted before starting the Manufacturing Process.

Code4 Not Accepted (Rejected)
Vendor/Sub-Contractor shall re-work/re-design/re-specify the contents of the document according to the comments/reasons for rejection. All corrected documents shall be resubmitted before starting the manufacturing. Vendor/Sub-Contractor shall not proceed with subsequent works of Material Supply or Manufacturing until receiving Code1/Code2 or No Code from PURCHASER. Vendor/Sub-Contractor shall resubmit the document with the same revision within 6 working days after receiving comments.

No Code No Code
(Only for "For Information" Documents and "As Built DWG") Document has been submitted for PURCHASER'S information. (F). Consistency, completeness and correctness of document content is in Vendor/Sub-Contractor's responsibility.

The above checking result by EIED shall in no way relieve Vendor of any liability, obligation and responsibility out of the purchase order and the mutual agreement in writing.

EIED

DATE :
DEPT :
Signature :

CV	PI	EL	IN	ME	MA
ST	BU	PR	SA	HV	TL

REV.	DATE (DD.MM.YY)	Purpose of Issue	Prepared	Checked	Approved
01	06-FEB-2026	IF1	D.SH	F.T	A.M
00	09-DEC-2025	IF1	D.SH	F.T	A.M

PO No.: GPIC-PT-MA-PO-000-3029
DRAWING TITLE: Instruments Hookup Diagram and MTO

DRAWING NO.	REV.	SHEET NO.	SIZE
VD-GPIC-MA-3029-3029-0051	01	18 of 39	A3

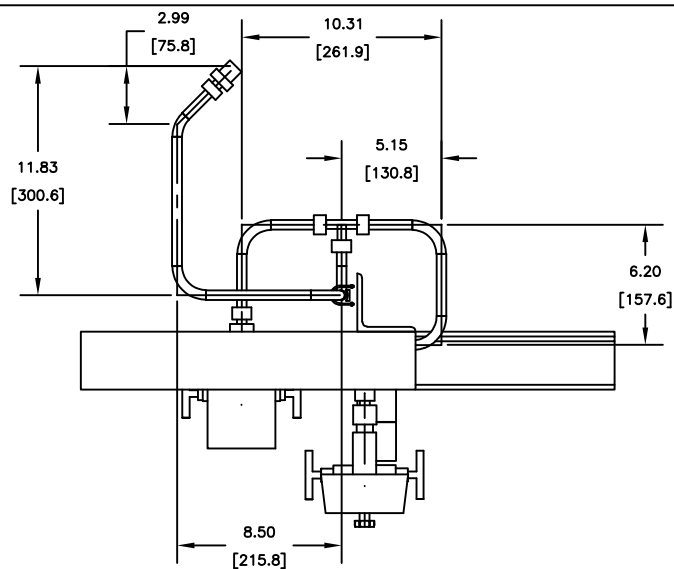

BILL OF MATERIALS				
PIPE				
ID	QTY	ND	DESCRIPTION	
1	5'-0 7/8"	1/2"	TUBING, ASTM A269, SEAMLESS - 316SS	0.065" THK
FITTINGS				
ID	QTY	ND	DESCRIPTION	
2	1	1/2"	BEND 45 5R, TUBING, ASTM A269, 316SS	
3	7	1/2"	BEND 90 5R, TUBING, ASTM A269, 316SS	
4	2	1/2"	PLUG, HEX HEAD, MPT, ASME B16.11	
5	1	3/4"x1/2"	Male Connector 3/4" NPT(M) x 1/2" T	
6	1	1/2"	Union_TEE_1/4" to 1"	
VALVES				
ID	QTY	ND	DESCRIPTION	
7	2	1/2"	2-Way-Manifold	
PIPE SUPPORTS				
ID	QTY	ND	DESCRIPTION	
8	2	1/2"	U-clamp	

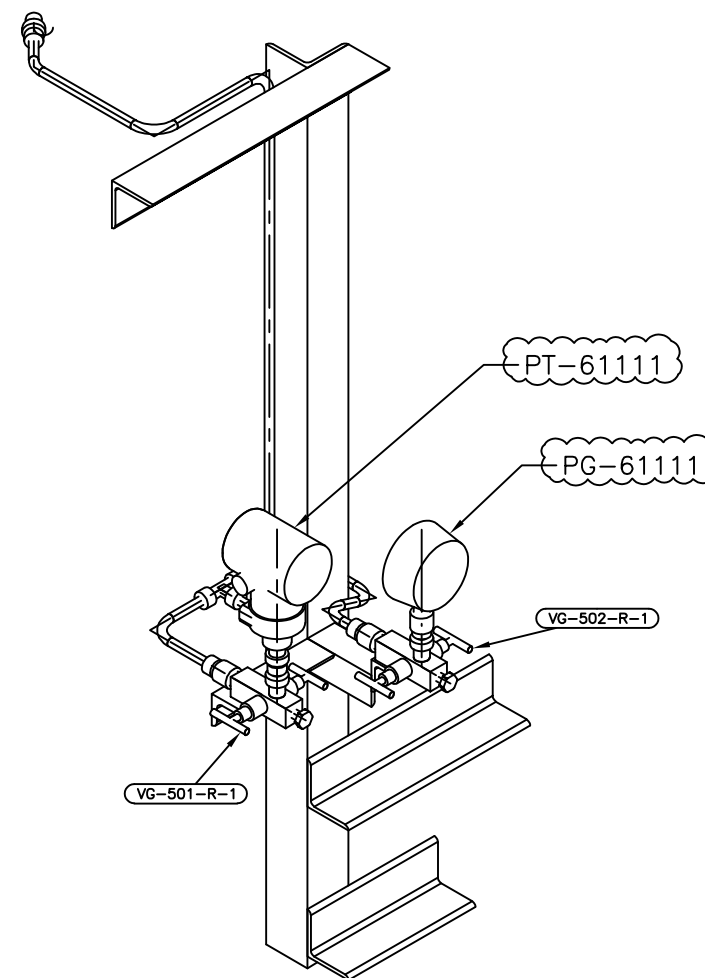
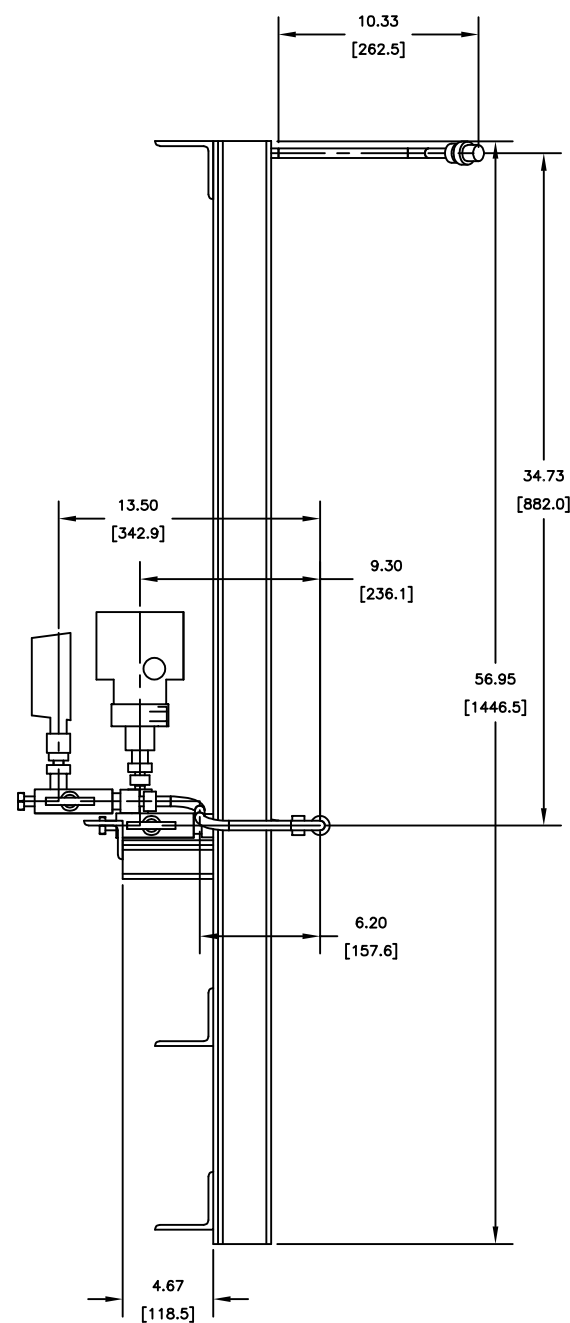
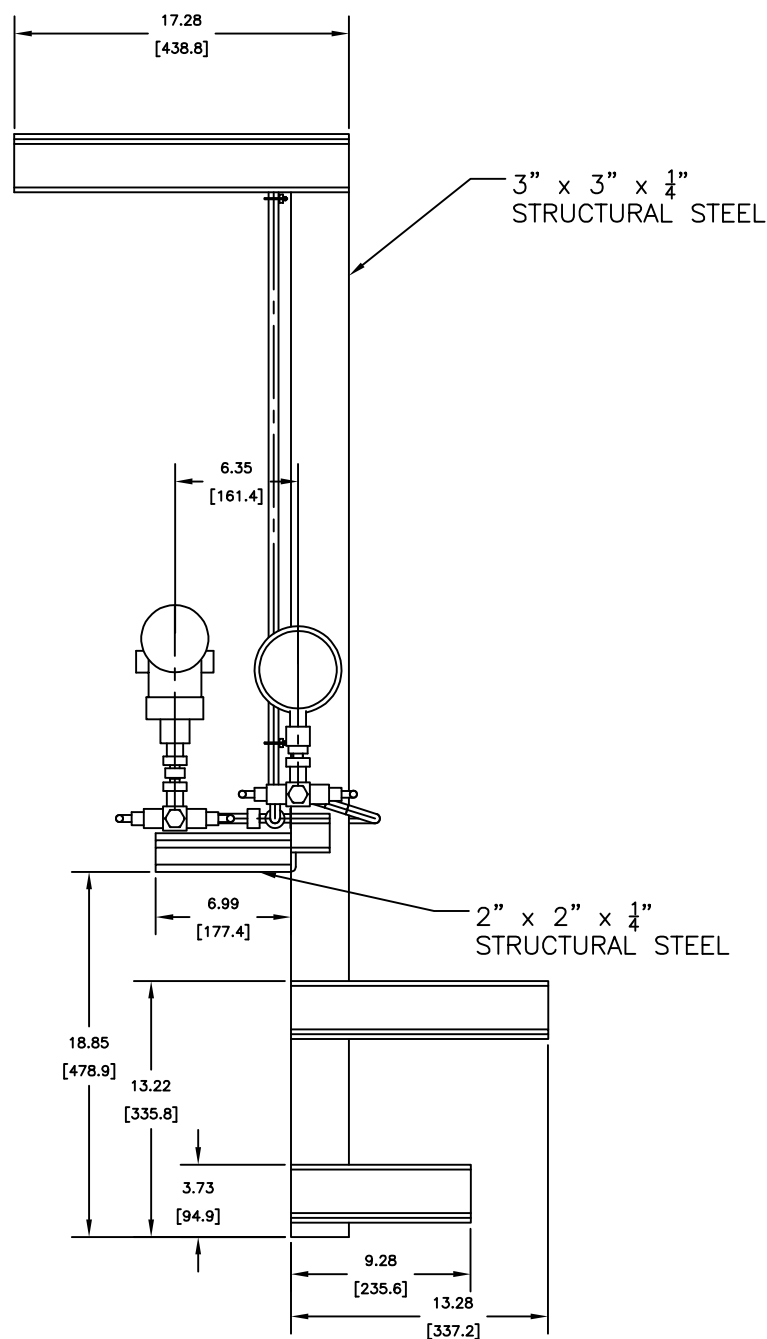

Code1	<input type="checkbox"/> No Comment/ Approved (Applicable Only for "FOR REVIEW" and "For Approval" Documents) No comment and the document are released for Manufacturing.
Code2	<input type="checkbox"/> No Comment/ Approved with Note(s) Vendor/Sub-Contractor shall correct, revise and resubmit the document. The document is released for Manufacturing if changes incorporated.
Code3	<input type="checkbox"/> Commented Vendor/Sub-Contractor shall correct, revise and resubmit the document by the date specified. The document shall be revised under the Status of "R: Revised Issue". All corrected documents shall be resubmitted before starting the Manufacturing Process.
Code4	<input type="checkbox"/> Not Accepted (Rejected) Vendor/Sub-Contractor shall re-work/re-design/re-specify the contents of the document according to the comments/reasons for rejection. All corrected documents shall be resubmitted before starting the manufacturing. Vendor/Sub-Contractor shall not proceed with subsequent works of Material Supply or Manufacturing until receiving Code1/Code2 or No Code from PURCHASER. Vendor/Sub-Contractor shall resubmit the document with the same revision within 6 working days after receiving comments.
No Code	<input type="checkbox"/> No Code (Only for "For Informative" Documents and "As Built DWG") Document has been submitted for PURCHASER'S INFORMATION (FI). Consistency, completeness and correctness of document content is in Vendor/Sub-Contractor's responsibility. The above checking result by EIED shall in no way relieve Vendor of any liability, obligation and responsibility out of the purchase order and the mutual agreement in writing.
DATE : DEPT : Signature :	
CV	PI
ST	BU
EL	PR
IN	SA
ME	HV
MA	TL

01	08-FEB-2028	IFI	D.SH	F.T	A.M
00	09-DEC-2025	IFI	D.SH	F.T	A.M
REV.	DATE (DD-MMM-YY)	Purpose of Issue	Prepared	Checked	Approved
		Gachsan Polymer Industries Company HDPE Plant			
PO No.: GPIC-PT-MA-PO-000-3029					SCALE: 1:1
DRAWING TITLE: Instruments Hookup Diagram and MTO					
DRAWING NO. VD-GPIC-MA-3029-3029-0051			REV. 01	SHEET NO. 19 of 39	SIZE A3

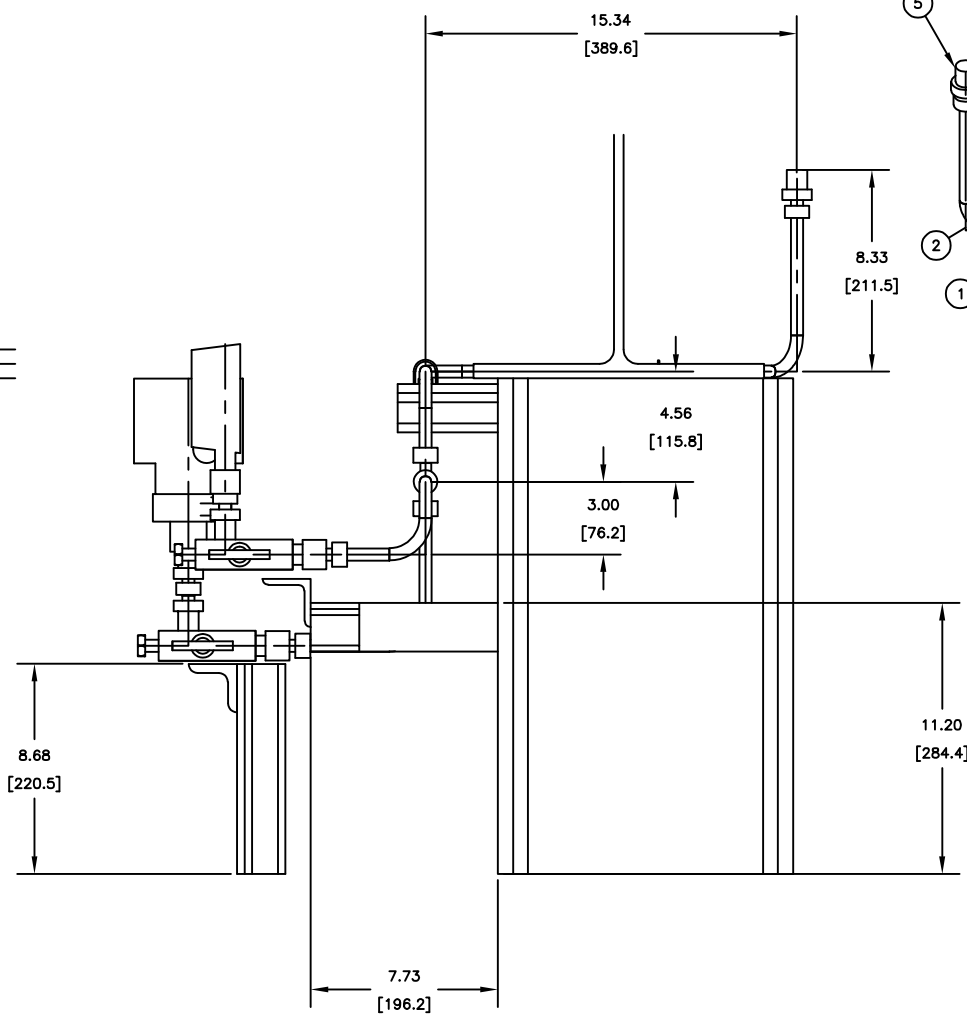
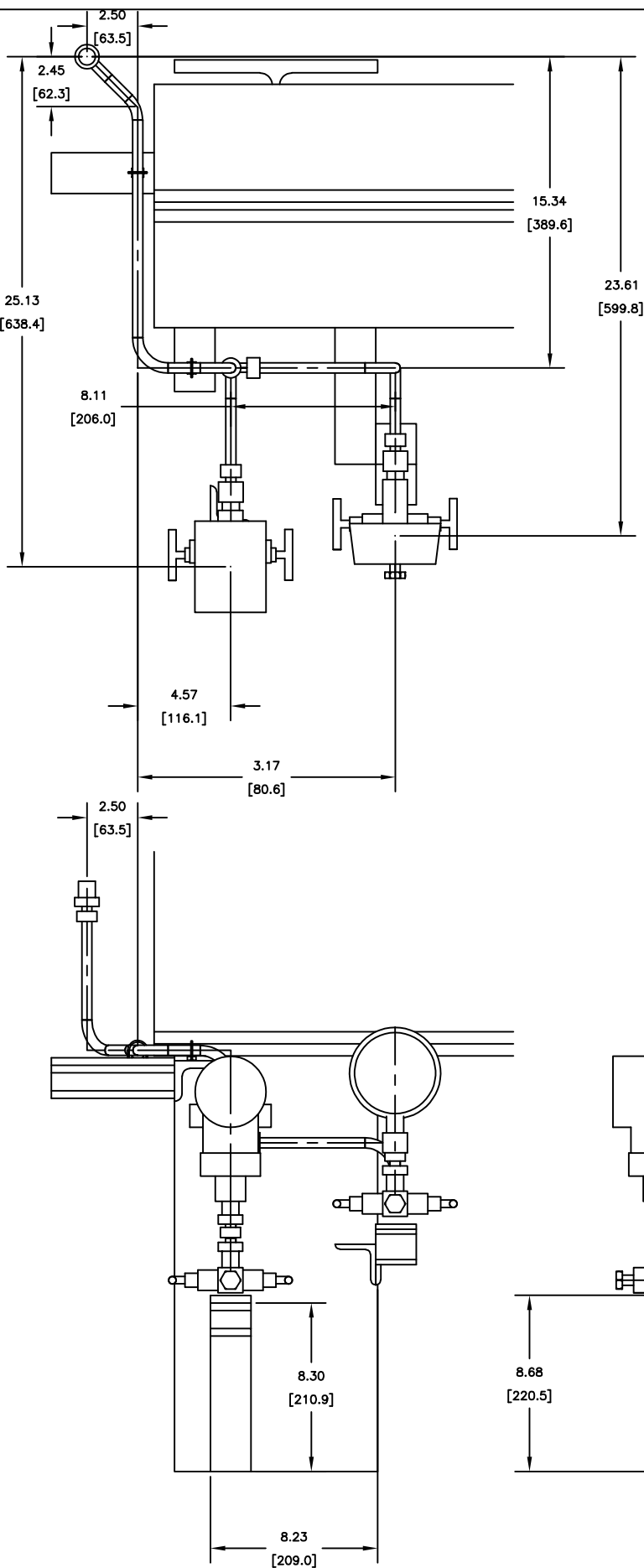

BILL OF MATERIALS				
PIPE				
ID	QTY	ND	DESCRIPTION	
1	3'-0	13/16"	TUBING, ASTM A269, SEAMLESS -- 316SS	0.065" THK
FITTINGS				
ID	QTY	ND	DESCRIPTION	
2	6	1/2"	BEND 90 5R, TUBING, ASTM A269, 316SS	
3	1	1/2"	BEND 45 5R, TUBING, ASTM A269, 316SS	
4	2	1/2"	PLUG, HEX HEAD, MPT, ASME B16.11	
5	1	3/4"x1/2"	Male Connector 3/4" NPT(M) x 1/2" T	
6	1	1/2"	Union_TEE_1/4" to 1"	
VALVES				
ID	QTY	ND	DESCRIPTION	
7	2	1/2"	2-Way-Manifold	
PIPE SUPPORTS				
ID	QTY	ND	DESCRIPTION	
8	2	1/2"	U-clamp	

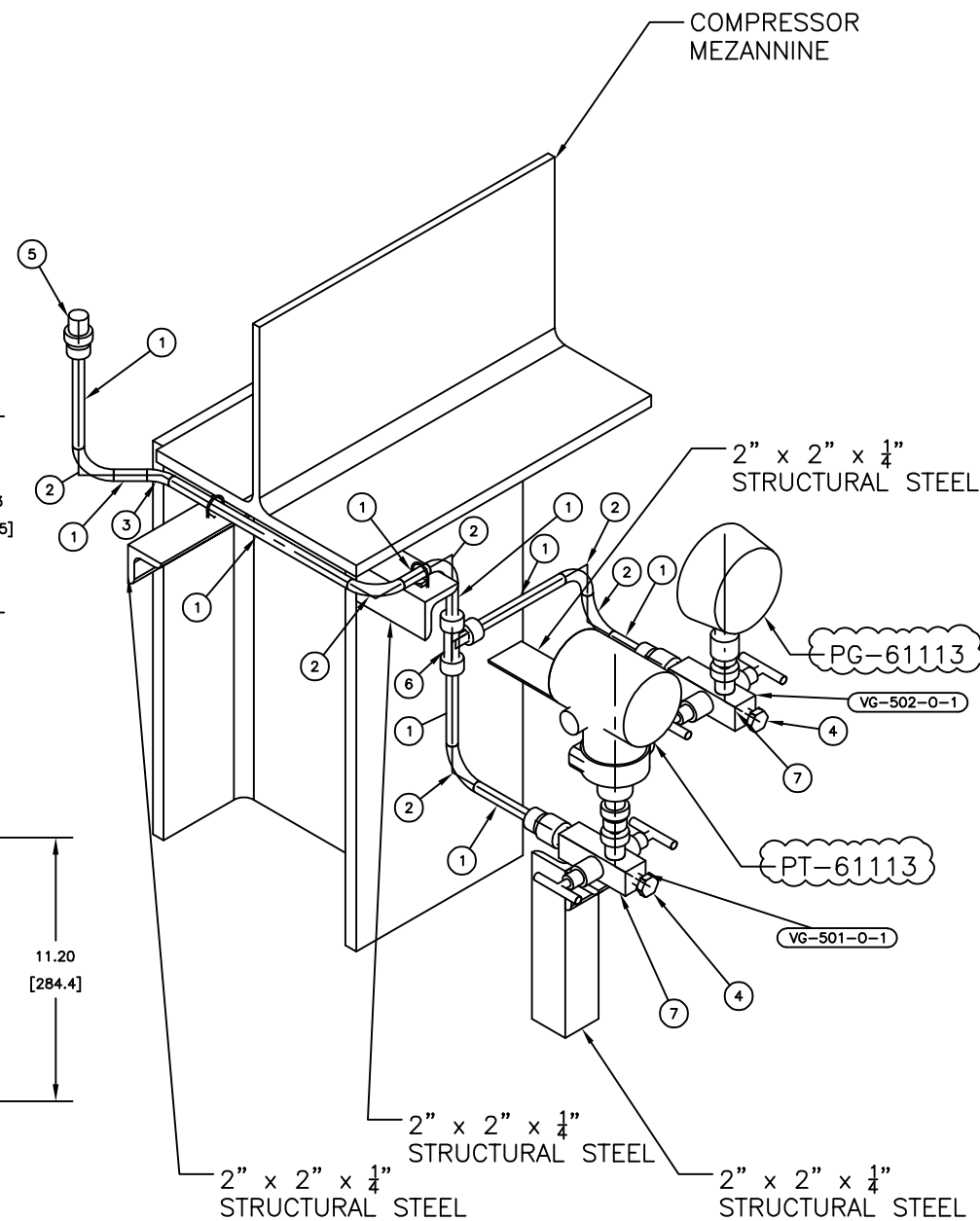

Code1 No Comment/ Approved
(Applicable Only for "FOR REVIEW" and "For Approval" Documents) No comment and the document are released for Manufacturing

Code2 No Comment/ Approved with Note(s)
Vendor/Sub-Contractor shall correct, revise and resubmit the document. The document is released for Manufacturing if changes incorporated.

Code3 Commented
Vendor/Sub-Contractor shall correct, revise and resubmit the document by the date specified. The document shall be revised under the Status of "Revised Issue". All corrected documents shall be resubmitted before starting the Manufacturing Process

Code4 Not Accepted (Rejected)
Vendor/Sub-Contractor shall re-work/re-design/re-specify the contents of the document according to the comments/ reasons for rejection. All corrected documents shall be resubmitted before starting the manufacturing. Vendor/Sub-Contractor shall not proceed with subsequent works of Material Supply or Manufacturing until receiving Code1/Code2 or No Code from PURCHASER. Vendor/Sub-Contractor shall resubmit the document with the same revision within 6 working days after receiving comments



No Code No Code
(Only for "For Information" Documents and "As Built DWGs") Document has been submitted for PURCHASER'S information (F). Consistency, completeness and correctness of document content is in Vendor/Sub-Contractor's responsibility.

The above checking result by EIED shall in no way relieve Vendor of any liability, obligation and responsibility out of the purchase order and the mutual agreement in writing.

EIED
DATE :
DEPT :
Signature :

CV	PI	EL	IN	ME	MA
ST	BU	PR	SA	HV	TL

REV.	DATE (DD.MM.YY)	Purpose of Issue	Prepared	Checked	Approved
01	06-FEB-2026	IFT	D.SH	F.T	A.M
00	06-DEC-2025	IFT	D.SH	F.T	A.M



Gachsaran Polymer Industries Company
HDPE Plant

PO No.: GPIC-PT-MA-PO-000-3029
 DRAWING TITLE:
Instruments Hookup Diagram and MTO

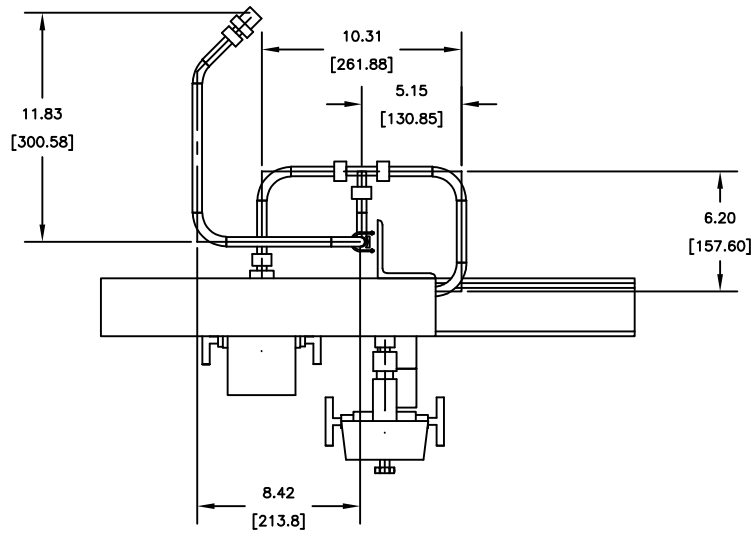
DRAWING NO.	REV.	SHEET NO.	SIZE
VD-GPIC-MA-3029-0051	01	20 of 39	A3

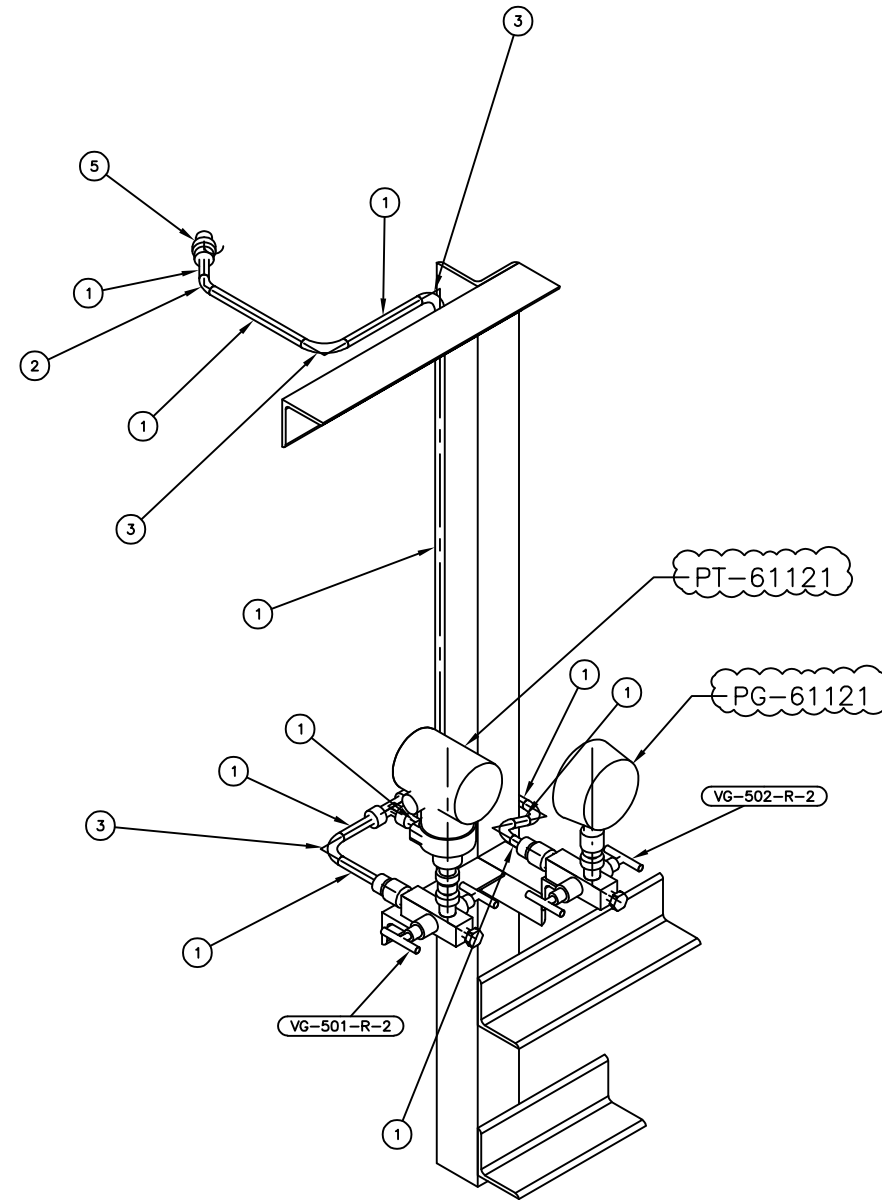
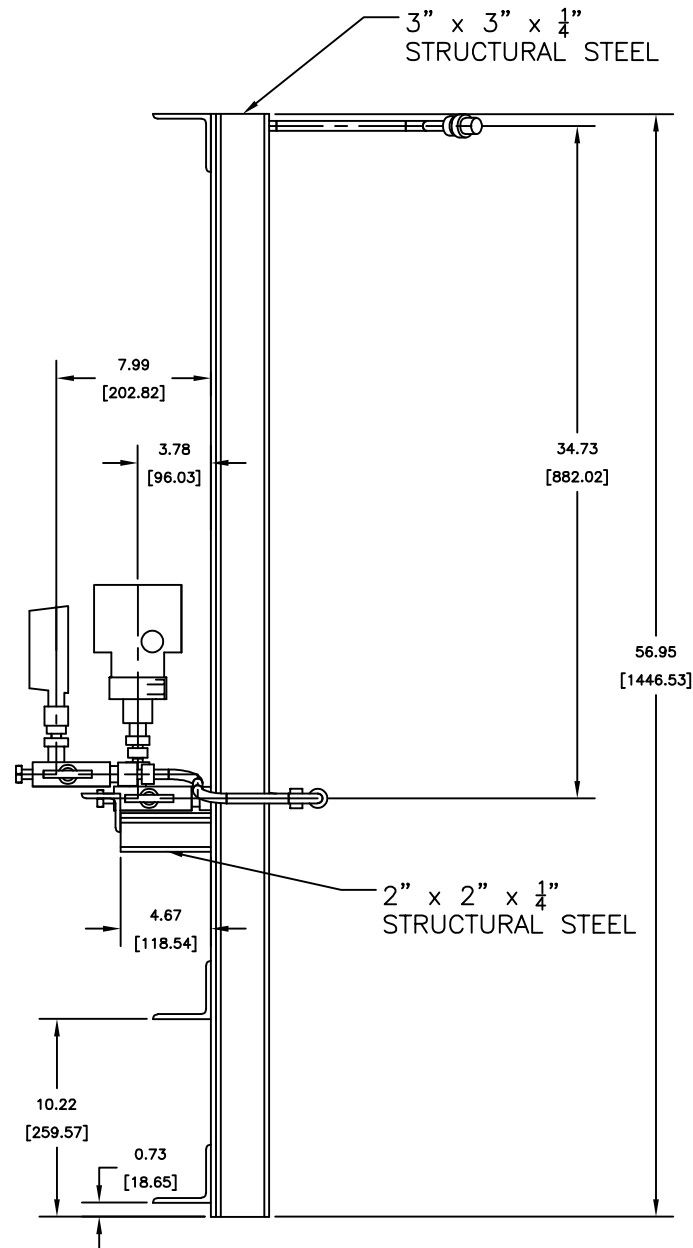
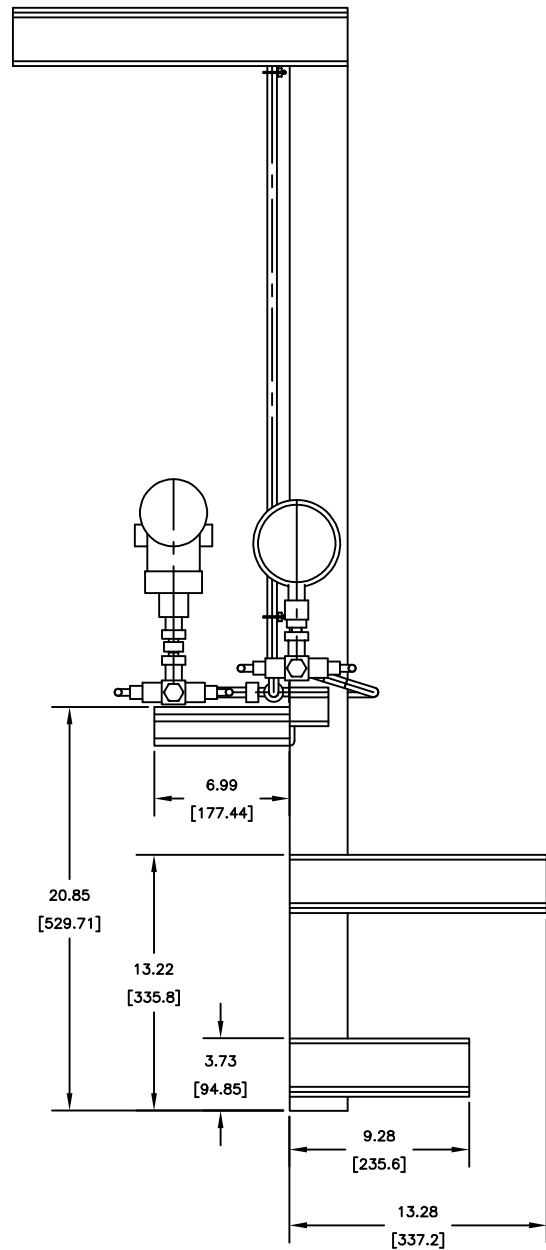

BILL OF MATERIALS				
PIPE				
ID	QTY	ND	DESCRIPTION	
1	5'-5 9/16"	1/2"	TUBING, ASTM A269, SEAMLESS -- 316SS	0.065" THK
FITTINGS				
ID	QTY	ND	DESCRIPTION	
2	1	1/2"	BEND 45 5R, TUBING, ASTM A269, 316SS	
3	7	1/2"	BEND 90 5R, TUBING, ASTM A269, 316SS	
4	2	1/2"	PLUG, HEX HEAD, MPT, ASME B16.11	
5	1	3/4"x1/2"	Male Connector 3/4" NPT(M) x 1/2" T	
6	1	1/2"	Union_TEE_1/4" to 1"	
VALVES				
ID	QTY	ND	DESCRIPTION	
7	2	1/2"	2-Way-Manifold	
PIPE SUPPORTS				
ID	QTY	ND	DESCRIPTION	
8	2	1/2"	U-clamp	



Code1	<input type="checkbox"/> No Comment/ Approved (Applicable Only for "FOR REVIEW" and "For Approval" Documents) No comment and the document are released for Manufacturing
Code2	<input type="checkbox"/> No Comment/ Approved with Note(s) Vendor/Sub-Contractor shall correct, revise and resubmit the document. The document is released for Manufacturing if changes incorporated.
Code3	<input type="checkbox"/> Commented Vendor/Sub-Contractor shall correct, revise and resubmit the document by the date specified. The document shall be revised under the Status of "Revised Issue". All corrected documents shall be resubmitted before starting the Manufacturing Process
Code4	<input type="checkbox"/> Not Accepted (Rejected) Vendor/Sub-Contractor shall re-work/re-design/re-specify the contents of the document according to the comments/reasons for rejection. All corrected documents shall be resubmitted before starting the manufacturing. Vendor/Sub-Contractor shall not proceed with subsequent works of Material Supply or Manufacturing until receiving Code1/Code2 or No Code from PURCHASER. Vendor/Sub-Contractor shall resubmit the document with the same revision within 6 working days after receiving comments
No Code	<input type="checkbox"/> No Code (Only for "For Information" Documents and "As Built DWGs") Document has been submitted for PURCHASER's information. (F). Consistency, completeness and correctness of document content is in Vendor/Sub-Contractor's responsibility.

The above checking result by EIED shall in no way relieve Vendor of any liability, obligation and responsibility out of the purchase order and the mutual agreement in writing

DATE :
DEPT :
Signature :

CV	PI	EL	IN	ME	MA
ST	BU	PR	SA	HV	TL

01	08-FEB-2028	IF1	D-SH	F-T	A-M
00	09-DEC-2025	IF1	D-SH	F-T	A-M
REV.	DATE (DD-MMM-YY)	Purpose of Issue	Prepared	Checked	Approved

PO No.: GPIC-PT-MA-PO-000-3029
DRAWING TITLE: Instruments Hookup Diagram and MTO
SCALE: 1:1

DRAWING NO.	REV.	SHEET NO.	SIZE
VD-GPIC-MA-3029-3029-0051	01	21 of 39	A3

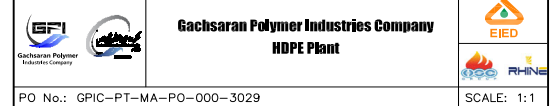

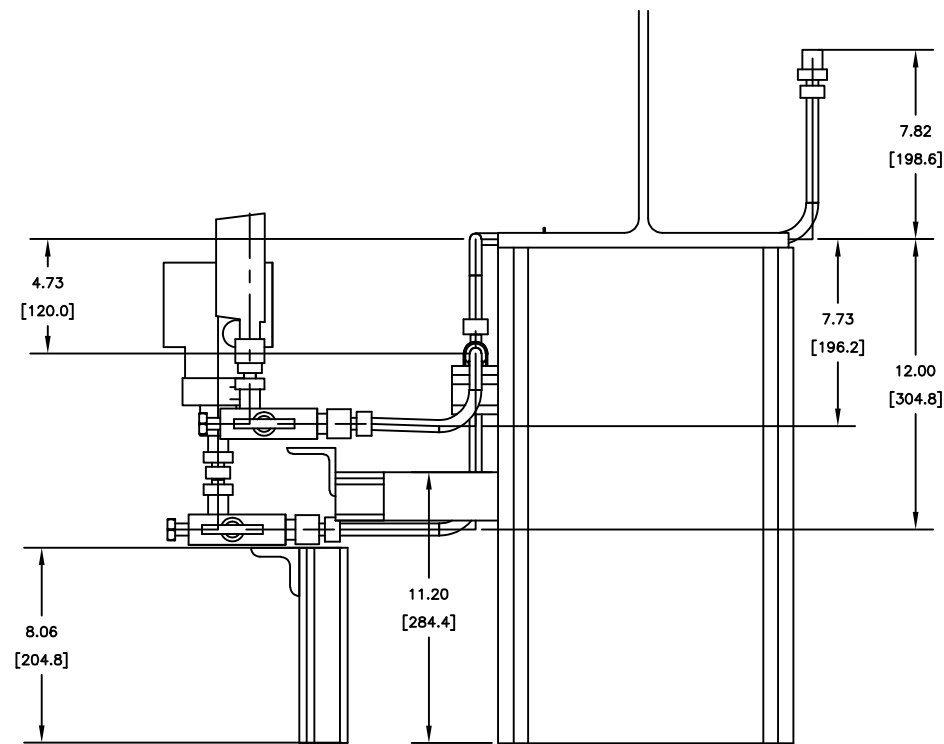
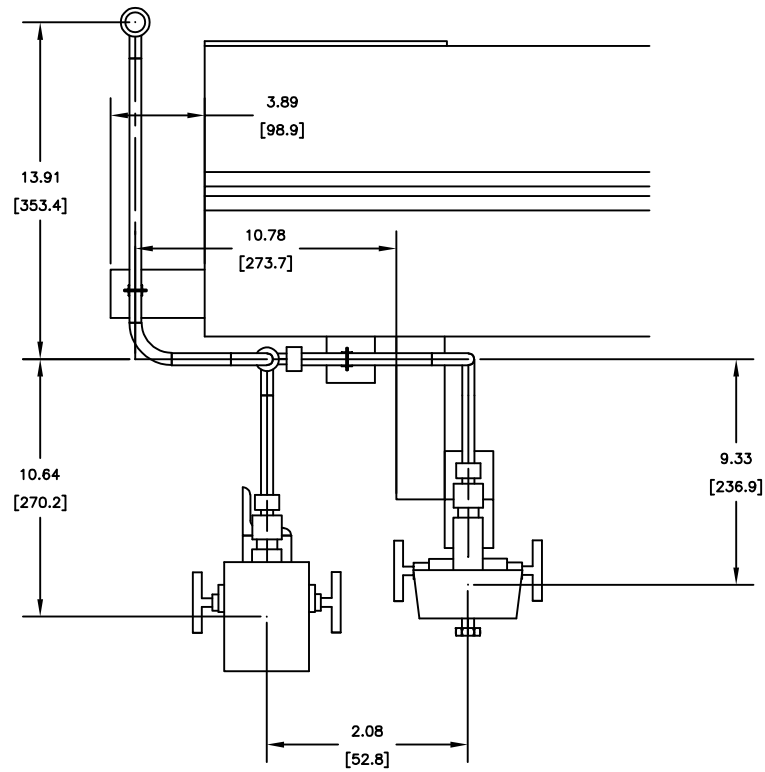

BILL OF MATERIALS				
PIPE				
ID	QTY	ND	DESCRIPTION	
1	3'-2 3/4"	1/2"	TUBING, ASTM A269, SEAMLESS - 316SS	0.065" THK
FITTINGS				
ID	QTY	ND	DESCRIPTION	
2	6	1/2"	BEND 90 5R, TUBING, ASTM A269, 316SS	
3	2	1/2"	PLUG, HEX HEAD, MPT, ASME B16.11	
4	1	3/4"x1/2"	Male Connector 3/4" NPT(M) x 1/2" T	
5	1	1/2"	Union_TEE_1/4" to 1"	
VALVES				
ID	QTY	ND	DESCRIPTION	
6	2	1/2"	2-Way-Manifold	
PIPE SUPPORTS				
ID	QTY	ND	DESCRIPTION	
7	2	1/2"	U-clamp	

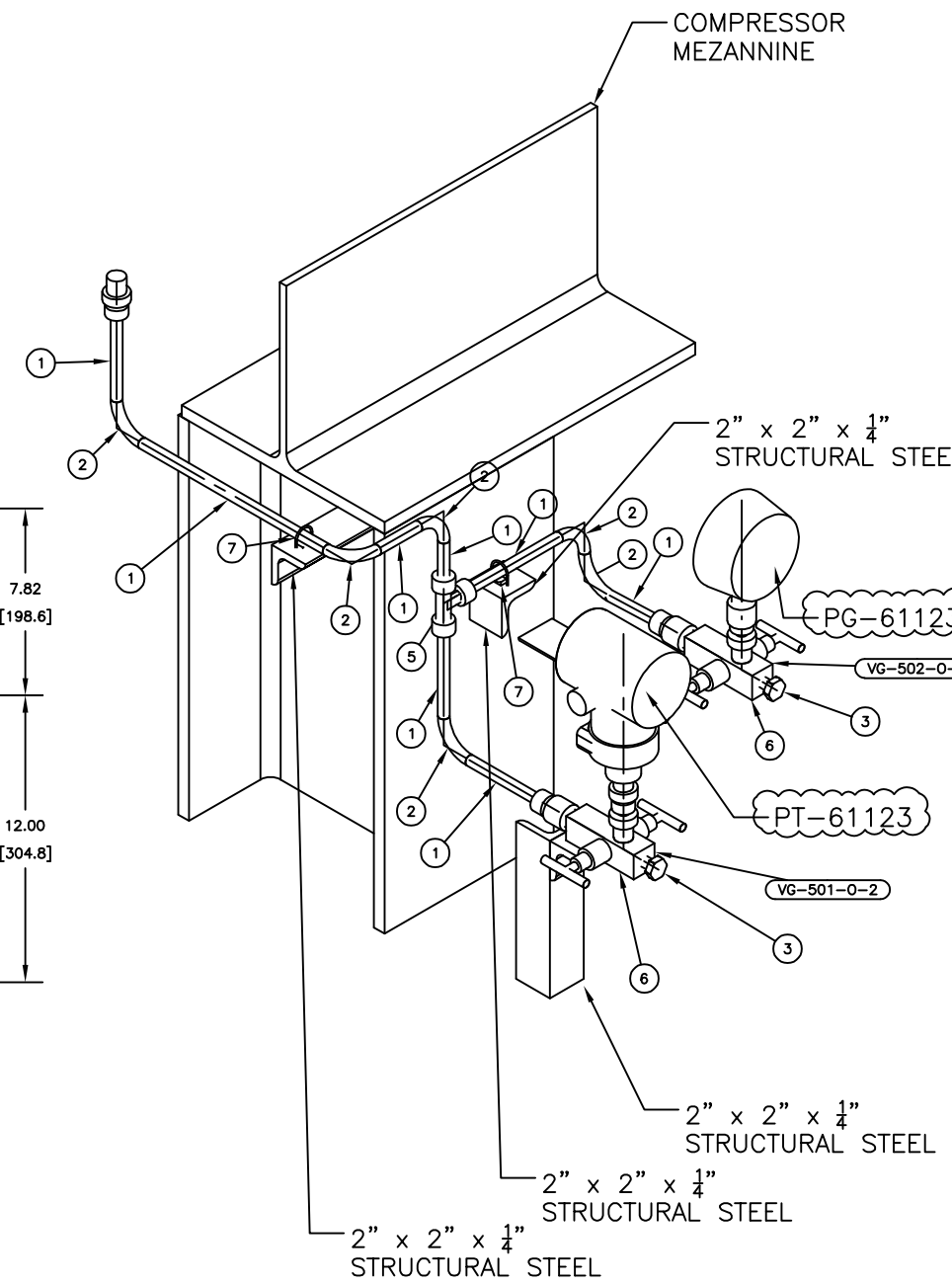

Code1	<input type="checkbox"/> No Comment/ Approved (Applicable Only for "FOR REVIEW" and "For Approval" Documents) No comment and the document are released for Manufacturing				
Code2	<input type="checkbox"/> No Comment/ Approved with Note(s) Vendor/Sub-Contractor shall correct, revise and resubmit the document. The document is released for Manufacturing if changes incorporated.				
Code3	<input type="checkbox"/> Commented Vendor/Sub-Contractor shall correct, revise and resubmit the document by the date specified. The document shall be resubmitted under the Status of "Re-revised issue". All corrected documents shall be resubmitted before starting the Manufacturing Process				
Code4	<input type="checkbox"/> Not Accepted (Rejected) Vendor/Sub-Contractor shall re-work/re-design/re-specify the contents of the document according to the comments/reasons for rejection. All corrected documents shall be resubmitted before starting the manufacturing. Vendor/Sub-Contractor shall not proceed with subsequent works of Material Supply or Manufacturing until receiving Code1/Code2 or No Code from PURCHASER. Vendor/Sub-Contractor shall resubmit the document with the same revision within 6 working days after receiving comments				
No Code	<input type="checkbox"/> No Code (Only for "For Information" Documents and "As Built DWG's") Document has been submitted for PURCHASER's Information (I). Consistency, completeness and correctness of document content is in Vendor/Sub-Contractor's responsibility.				
The above checking result by EIED shall in no way relieve Vendor of any liability, obligation and responsibility out of the purchase order and the mutual agreement in writing					
DATE : _____ DEPT: _____ Signature : _____					
CV	PI	EL	IN	ME	MA
ST	BU	PR	SA	HV	TL

01	06-FEB-2020	IFI	D.SH	F.T	A.M
00	09-DEC-2019	IFI	D.SH	F.T	A.M
REV.	DATE (DD.MM.YY)	Purpose of Issue	Prepared	Checked	Approved
		Gachsan Polymer Industries Company HDPE Plant			
PO No.: GPIC-PT-MA-PO-000-3029			SCALE: 1:1		
DRAWING TITLE: Instruments Hookup Diagram and MTO					
DRAWING NO. VD-GPIC-MA-3029-3029-0051			REV.	SHEET NO.	SIZE
			01	22 of 39	A3

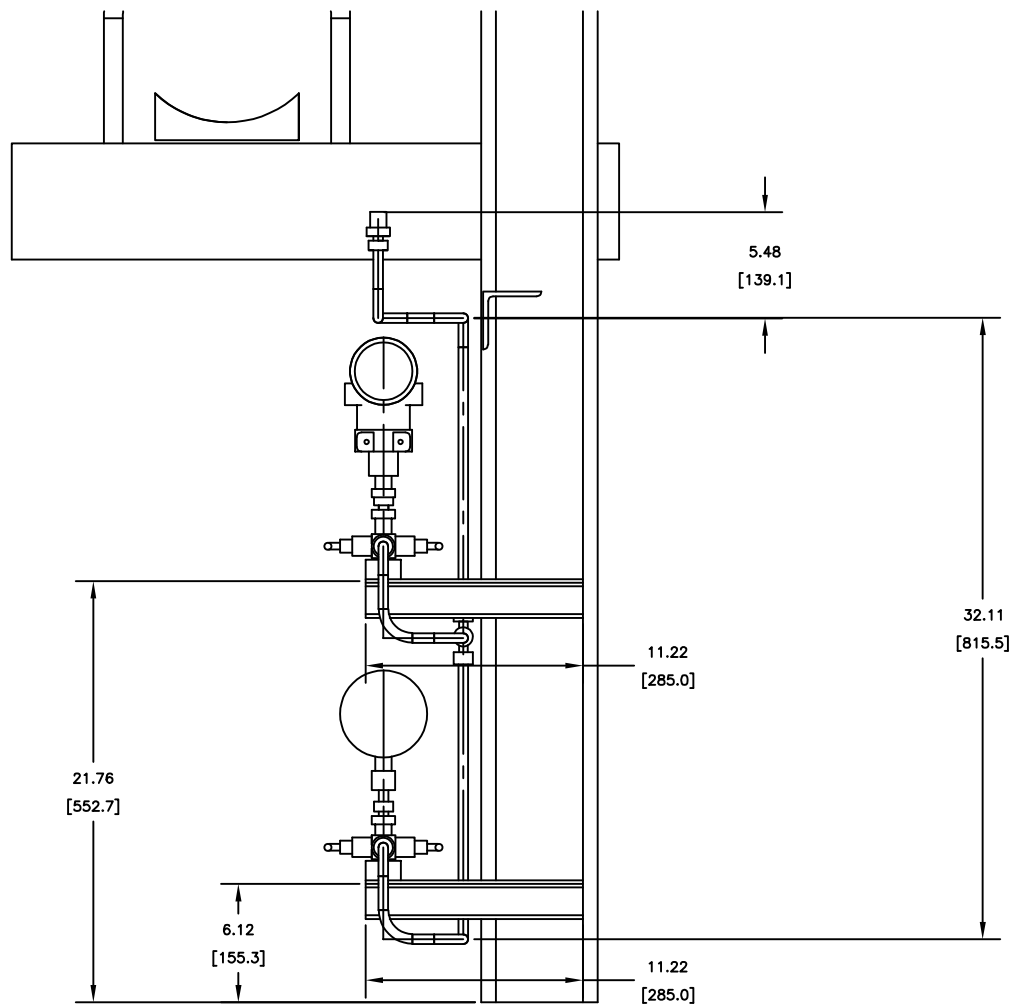
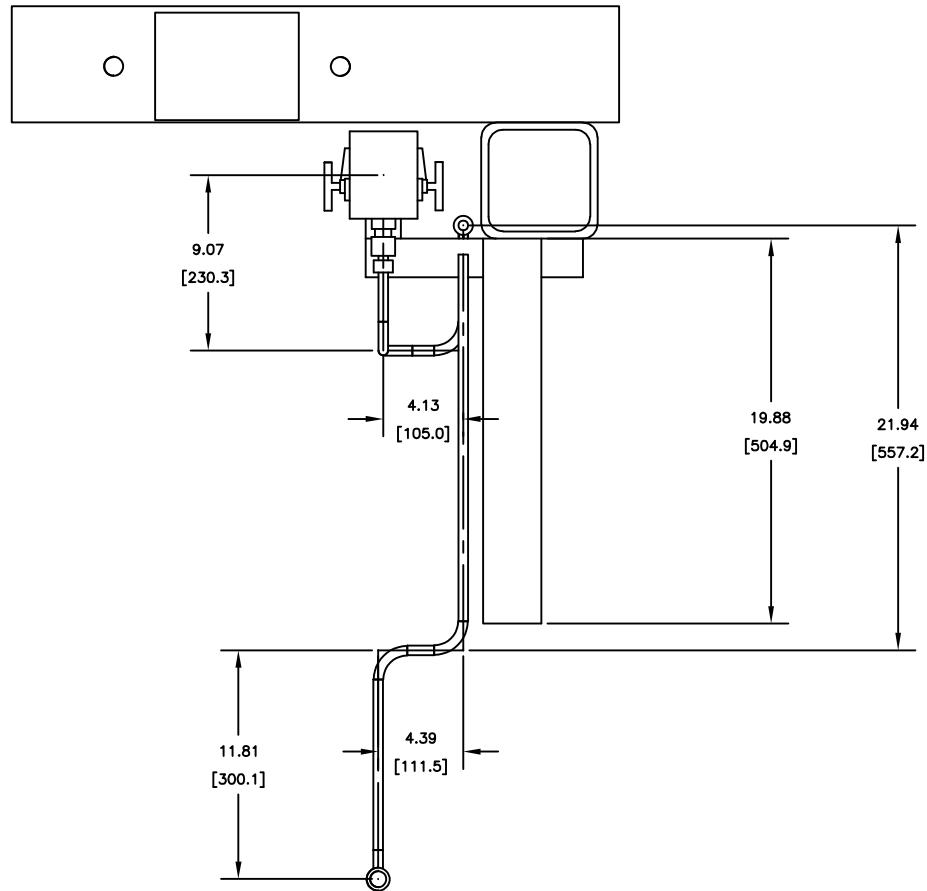

BILL OF MATERIALS				
PIPE				
ID	QTY	ND	DESCRIPTION	
1	6'-5 5/16"	1/2"	TUBING, ASTM A269, SEAMLESS - 316SS	0.065" THK
FITTINGS				
ID	QTY	ND	DESCRIPTION	
2	11	1/2"	BEND 90 5R, TUBING, ASTM A269, 316SS	
3	2	1/2"	PLUG, HEX HEAD, MPT, ASME B16.11	
4	1	3/4"x1/2"	Male Connector 3/4" NPT(M) x 1/2" T	
5	1	1/2"	Union_TEE_1/4" to 1"	
VALVES				
ID	QTY	ND	DESCRIPTION	
6	2	1/2"	2-Way-Manifold	
PIPE SUPPORTS				
ID	QTY	ND	DESCRIPTION	
7	1	10"	U-clamp	

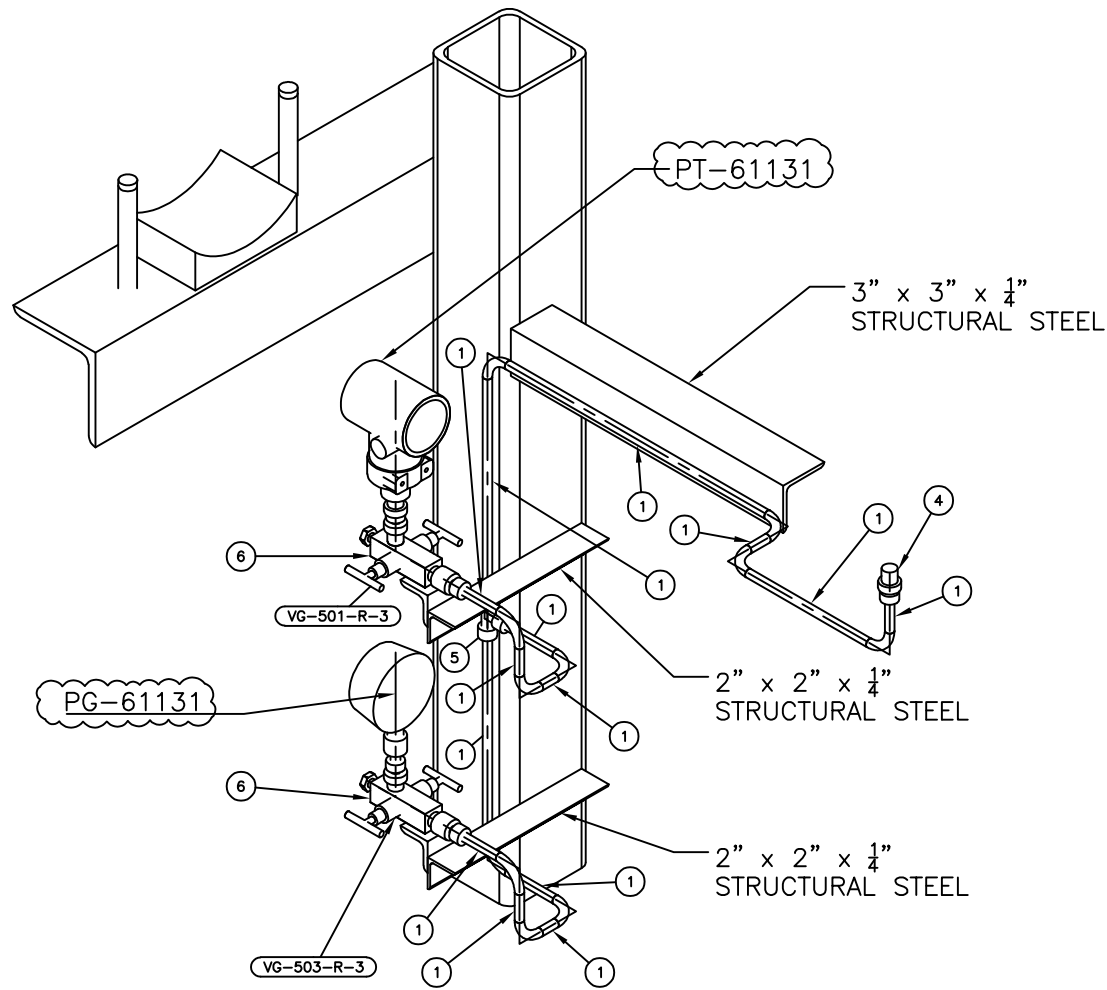

Code1	<input type="checkbox"/> No Comment/ Approved (Applicable Only for "FOR REVIEW" and "For Approval" Documents) No comment and the document are released for Manufacturing				
Code2	<input type="checkbox"/> No Comment/ Approved with Note(s) Vendor/Sub-Contractor shall correct, revise and resubmit the document. The document is released for Manufacturing if changes incorporated.				
Code3	<input type="checkbox"/> Commented Vendor/Sub-Contractor shall correct, revise and resubmit the document by the date specified. The document shall be revised under the Status of "R: Revised Issue". All corrected documents shall be resubmitted before starting the Manufacturing Process				
Code4	<input type="checkbox"/> Not Accepted (Rejected) Vendor/Sub-Contractor shall re-work/re-design/re-specify the contents of the document according to the comments/ reasons for rejection. All corrected documents shall be resubmitted before starting the manufacturing. Vendor Sub-Contractor shall not proceed with subsequent works of Material Supply or Manufacturing until receiving Code1/Code2 or No Code from PURCHASER. Vendor/Sub-Contractor shall resubmit the document with the same revision within 6 working days after receiving comments				
No Code	<input type="checkbox"/> No Code (Only for "For Information" Documents and "As Built (DWG)") Document has been submitted for PURCHASER'S information (FI). Consistency, completeness and correctness of document content is in Vendor/Sub-Contractor's responsibility.				
The above checking result by EIED shall in no way relieve Vendor of any liability, obligation and responsibility out of the purchase order and the mutual agreement in writing					
DATE :					
DEPT :					
Signature :					
CV	PI	EL	IN	ME	MA
ST	BU	PR	SA	HV	TL

01	08-FEB-2026	IFI	D.SH	F.T	A.M
00	09-DEC-2025	IFI	D.SH	F.T	A.M
REV.	DATE (DD-MMM-YY)	Purpose of Issue	Prepared	Checked	Approved
Gachsaran Polymer Industries Company					
HDPE Plant					
PO No.: GPIC-PT-MA-PO-000-3029					SCALE: 1:1
DRAWING TITLE:					
Instruments Hookup Diagram and MTO					
DRAWING NO.			REV.	SHEET NO.	SIZE
VD-GPIC-MA-3029-3029-0051			01	23 of 39	A3

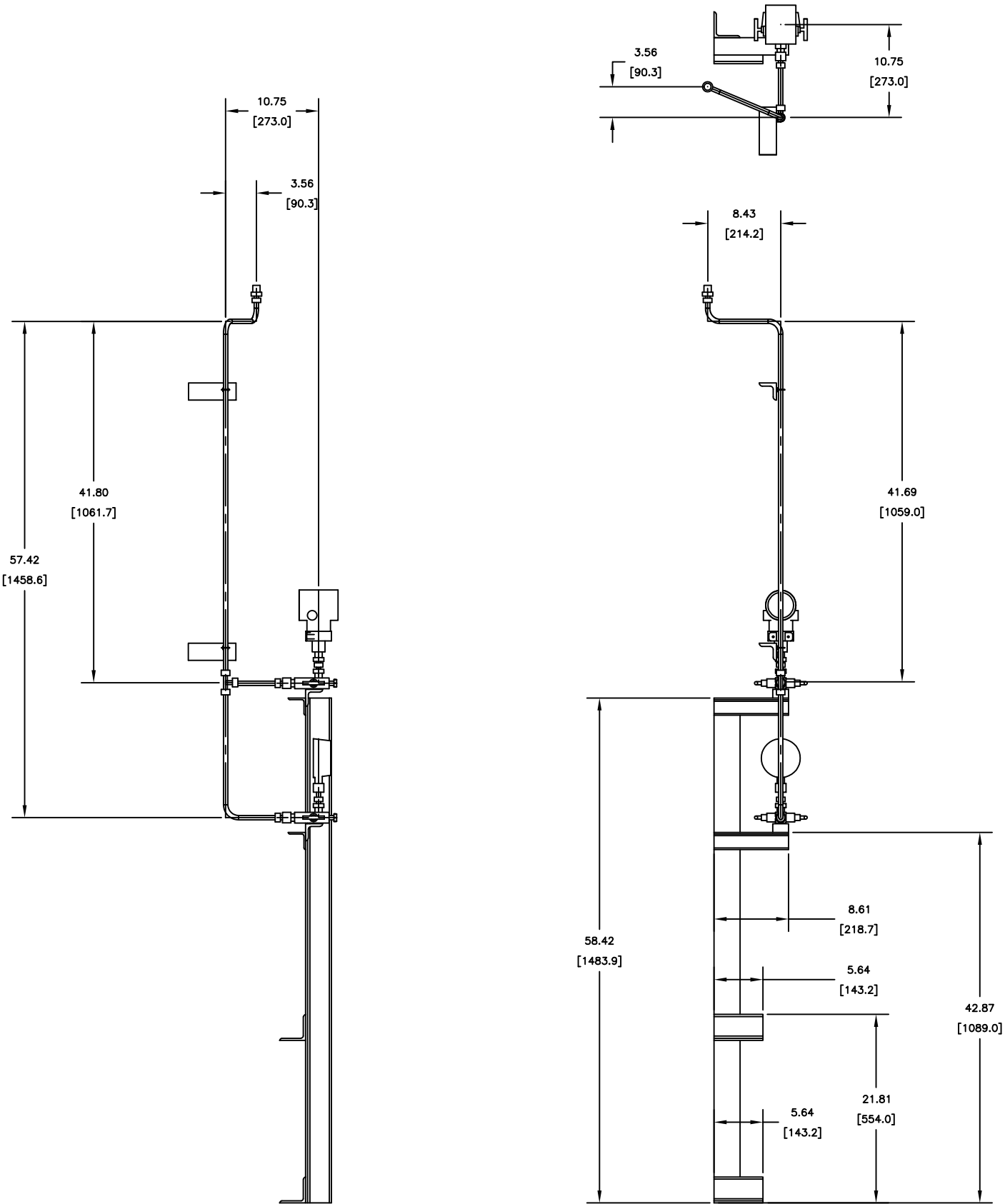

BILL OF MATERIALS			
PIPE			
ID	QTY	ND	DESCRIPTION
1	5'-9 1/8"	1/2"	TUBING, ASTM A269, SEAMLESS - 316SS
0.065" THK			
FITTINGS			
ID	QTY	ND	DESCRIPTION
2	3	1/2"	BEND 90 5R, TUBING, ASTM A269, 316SS
3	2	1/2"	PLUG, HEX HEAD, MPT, ASME B16.11
4	1	3/4"x1/2"	Male Connector 3/4" NPT(M) x 1/2" T
5	1	1/2"	Union_TEE_1/4" to 1"
VALVES			
ID	QTY	ND	DESCRIPTION
6	1	1/2"	2-Way-Manifold
PIPE SUPPORTS			
ID	QTY	ND	DESCRIPTION
7	2	1/2"	U-clamp

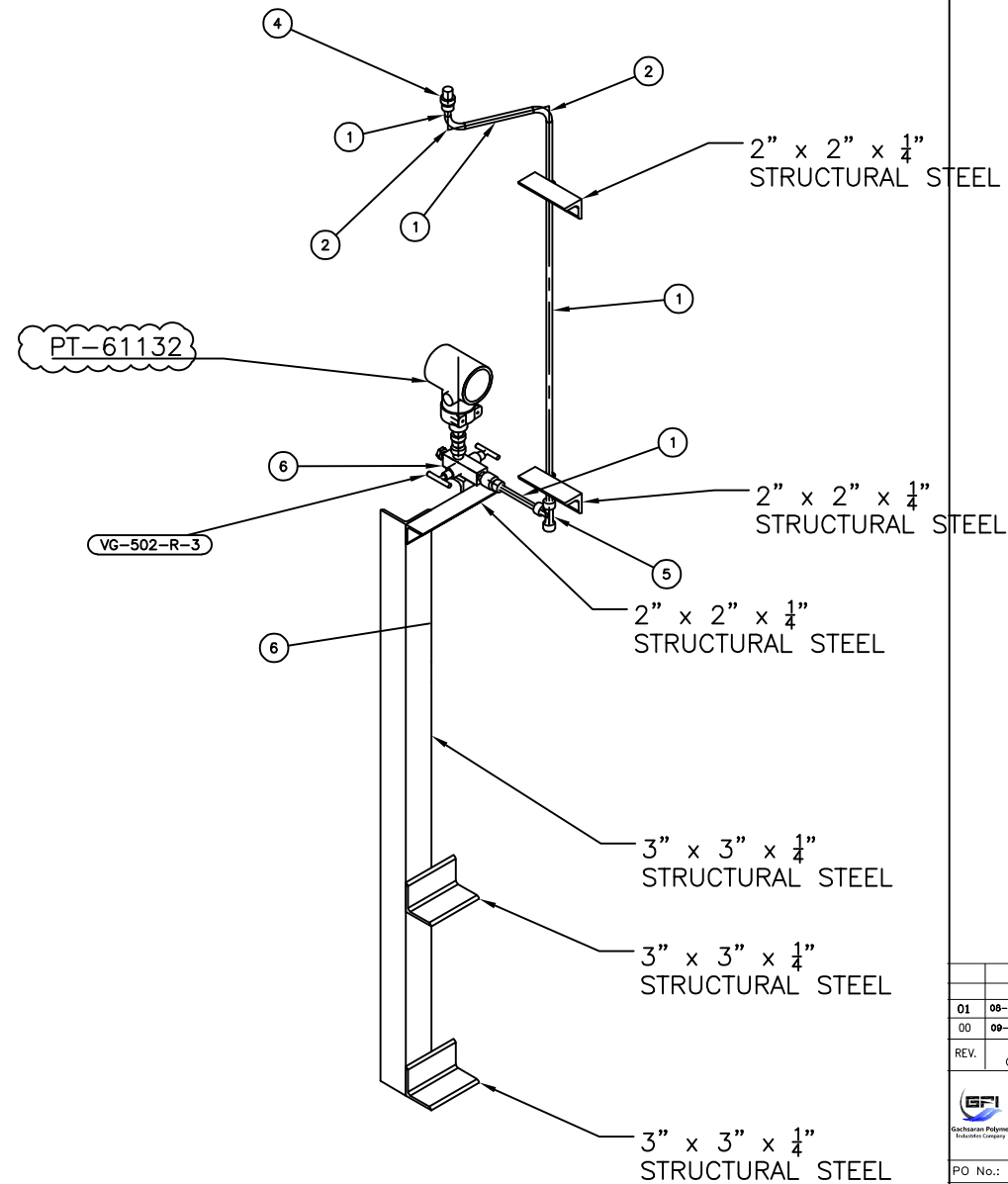

Code1	<input type="checkbox"/> No Comment/ Approved (Applicable Only for "FOR REVIEW" and "For Approval" Documents) No comment and the document are released for Manufacturing
Code2	<input type="checkbox"/> No Comment/ Approved with Note(s) Vendor/Sub-Contractor shall correct, revise and resubmit the document. The document is released for Manufacturing if changes incorporated.
Code3	<input type="checkbox"/> Commented Vendor/Sub-Contractor shall correct, revise and resubmit the document by the date specified. The document shall be revised under the Status of "R- Revised Issue". All corrected documents shall be resubmitted before starting the Manufacturing Process
Code4	<input type="checkbox"/> Not Accepted (Rejected) Vendor/Sub-Contractor shall re-work/re-design/re-specify the contents of the document according to the comments/ reasons for rejection. All corrected documents shall be resubmitted before starting the manufacturing. Vendor Sub-Contractor shall not proceed with subsequent works of Material Supply or Manufacturing until receiving Code1/Code2 or No Code from PURCHASER. Vendor/Sub-Contractor shall resubmit the document with the same revision within 6 working days after receiving comments
No Code	<input type="checkbox"/> No Code (Only for "For Information" Documents and "As Built DWG") Document has been submitted for PURCHASER'S Information (F). Consistency, completeness and correctness of document content is in Vendor/Sub-Contractor's responsibility. The above checking result by EIED shall in no way relieve Vendor of any liability, obligation and responsibility out of the purchase order and the mutual agreement in writing
DATE :	
DEPT :	
Signature :	
CV	PI
ST	BU
EL	PR
IN	SA
ME	HV
MA	TL

01	08-FEB-2026	IFI	D.SH	F.T	A.M
00	09-DEC-2025	IFI	D.SH	F.T	A.M
REV.	DATE (DD-MMM-YY)	Purpose of Issue	Prepared	Checked	Approved
PO No.: GPIC-PT-MA-PO-000-3029					SCALE: 1:1
DRAWING TITLE: Instruments Hookup Diagram and MTO					
DRAWING NO. VD-GPIC-MA-3029-3029-0051			REV.	SHEET NO.	SIZE
			01	24 of 39	A3

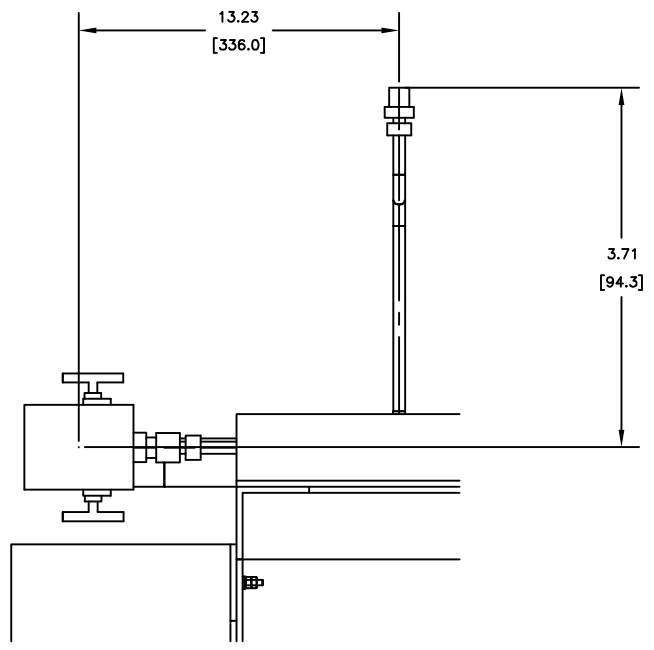

BILL OF MATERIALS			
PIPE			
ID	QTY	ND	DESCRIPTION
1	1'-4	7/16"	TUBING, ASTM A269, SEAMLESS - 316SS
FITTINGS			
ID	QTY	ND	DESCRIPTION
2	2	1/2"	BEND 45 5R, TUBING, ASTM A269, 316SS
3	1	1/2"	BEND 90 5R, TUBING, ASTM A269, 316SS
4	1	1/2"	PLUG, HEX HEAD, MPT, ASME B16.11
VALVES			
ID	QTY	ND	DESCRIPTION
5	1	1/2"	2-Way-Manifold

0.065" THK

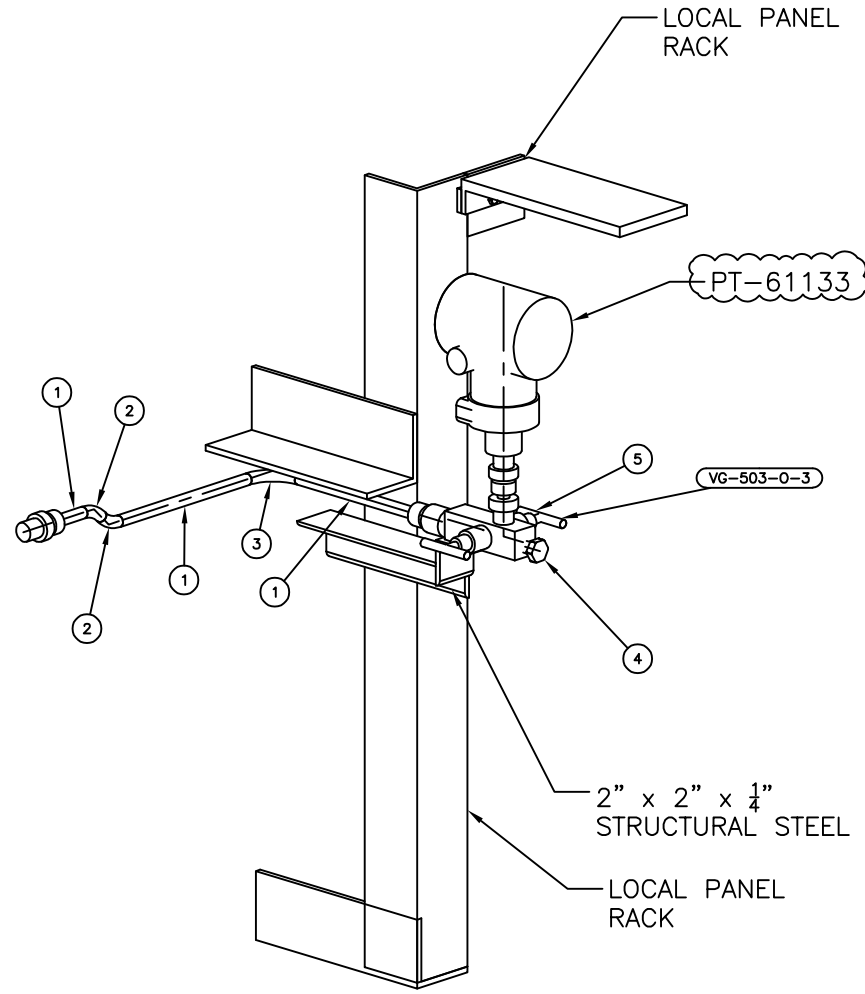
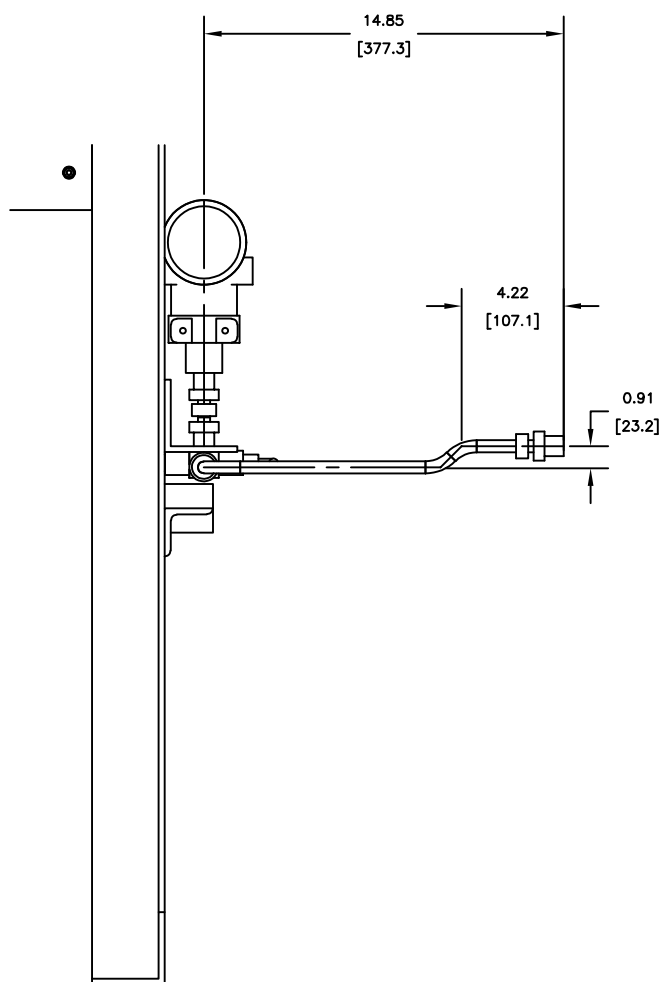
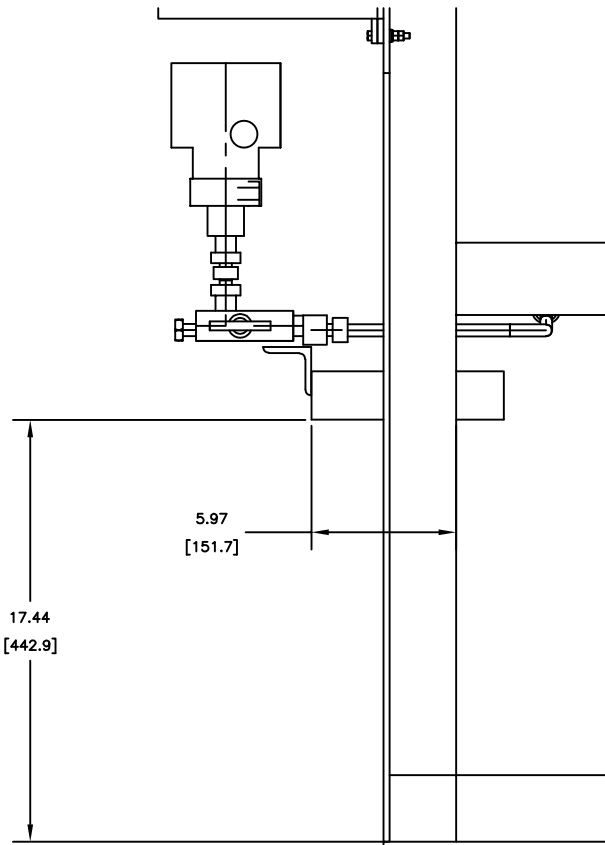



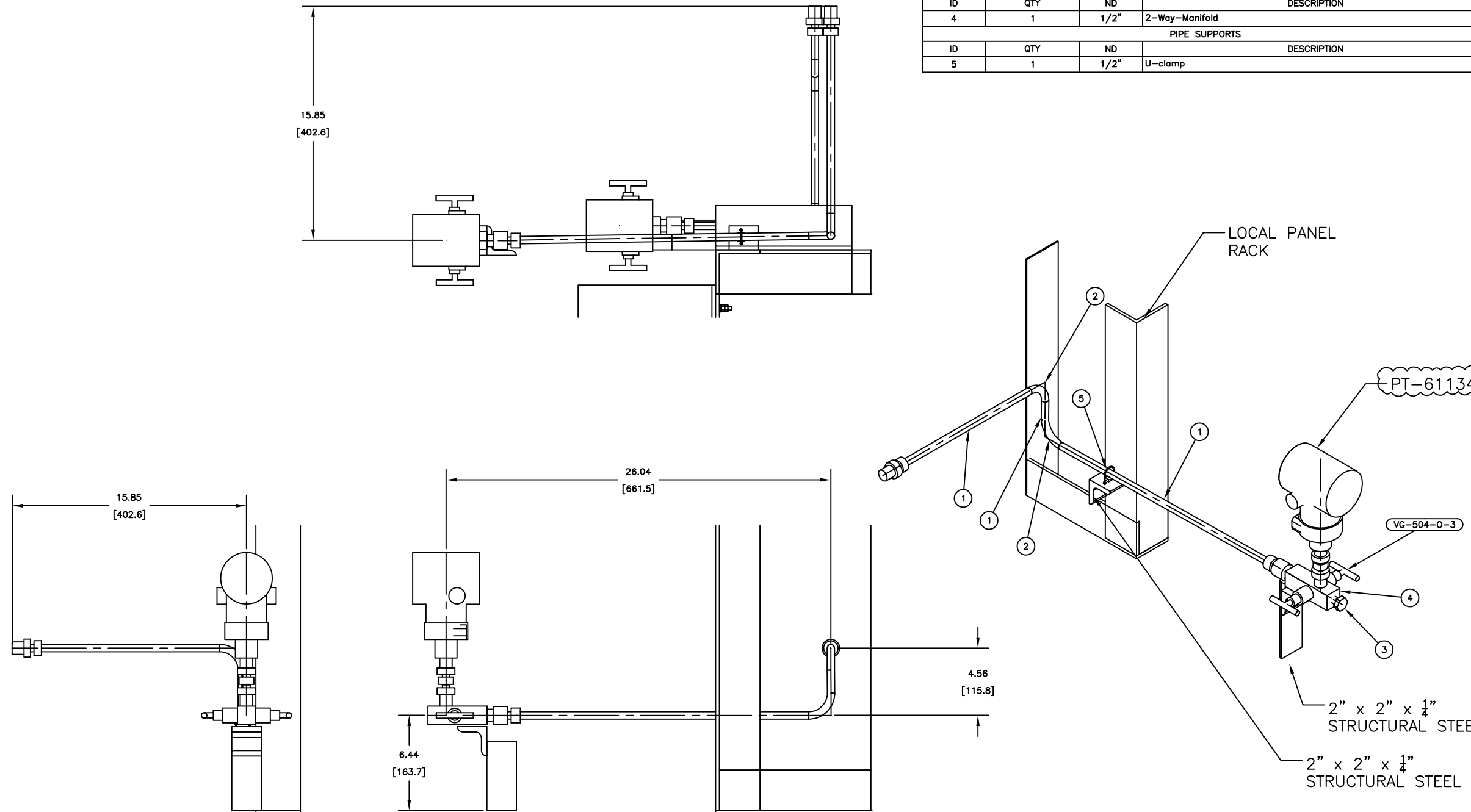

Code1	<input type="checkbox"/> No Comment/ Approved (Applicable Only for "FOR REVIEW" and "For Approval" Documents) No comment and the document are released for Manufacturing
Code2	<input type="checkbox"/> No Comment/ Approved with Note(s) Vendor/Sub-Contractor shall correct, revise and resubmit the document. The document is released for Manufacturing if changes incorporated.
Code3	<input type="checkbox"/> Commented Vendor/Sub-Contractor shall correct, revise and resubmit the document by the date specified. The document shall be revised under the Status of "K: Revised Issue". All corrected documents shall be resubmitted before starting the Manufacturing Process
Code4	<input type="checkbox"/> Not Accepted (Rejected) Vendor/Sub-Contractor shall re-work/re-design/re-specify the contents of the document according to the comments/reasons for rejection. All corrected documents shall be resubmitted before starting the manufacturing. Vendor Sub-Contractor shall not proceed with subsequent works of Material Supply or Manufacturing until receiving Code1/Code2 or No Code from PURCHASER. Vendor/Sub-Contractor shall resubmit the document with the same revision within 6 working days after receiving comments
No Code	<input type="checkbox"/> No Code (Only for "For Information" Documents and "As Built DWG's") Document has been submitted for PURCHASER's information (FI). Consistency, completeness and correctness of document content is in Vendor/Sub-Contractor's responsibility.
The above checking result by EIED shall in no way relieve Vendor of any liability, obligation and responsibility out of the purchase order and the mutual agreement in writing	
CV	PI
ST	BU
EL	PR
IN	SA
ME	HV
MA	TL

01	08-FEB-2026	IFI	D.SH	F.T	A.M
00	09-DEC-2025	IFI	D.SH	F.T	A.M
REV.	DATE (DD.MM.YY)	Purpose of Issue	Prepared	Checked	Approved
		Gachsaran Polymer Industries Company HDPE Plant			
PO No.: GPIC-PT-MA-PO-000-3029					SCALE: 1:1
DRAWING TITLE: Instruments Hookup Diagram and MTO					
DRAWING NO. VD-GPIC-MA-3029-3029-0051			REV.	SHEET NO.	SIZE
			01	25 of 39	A3

BILL OF MATERIALS				
PIPE				
ID	QTY	ND	DESCRIPTION	
1	2'-9 5/8"	1/2"	TUBING, ASTM A269, SEAMLESS - 316SS	0.065" THK
FITTINGS				
ID	QTY	ND	DESCRIPTION	
2	2	1/2"	BEND 90 5R, TUBING, ASTM A269, 316SS	
3	1	1/2"	PLUG, HEX HEAD, MPT, ASME B16.11	
VALVES				
ID	QTY	ND	DESCRIPTION	
4	1	1/2"	2-Way-Manifold	
PIPE SUPPORTS				
ID	QTY	ND	DESCRIPTION	
5	1	1/2"	U-clamp	



Code1	<input type="checkbox"/> No Comment/ Approved (Applicable Only for "FOR REVIEW" and "For Approval" Documents) No comment and the document are released for Manufacturing				
Code2	<input type="checkbox"/> No Comment/ Approved with Note(s) Vendor/Sub-Contractor shall correct, revise and resubmit the document. The document is released for Manufacturing if changes incorporated.				
Code3	<input type="checkbox"/> Commented Vendor/Sub-Contractor shall correct, revise and resubmit the document by the date specified. The document shall be revised under the Status of "R: Revised Issue". All corrected documents shall be resubmitted before starting the Manufacturing Process				
Code4	<input type="checkbox"/> Not Accepted (Rejected) Vendor/Sub-Contractor shall re-work/re-design/re-specify the contents of the document according to the comments/reasons for rejection. All corrected documents shall be resubmitted before starting the manufacturing. Vendor Sub-Contractor shall not proceed with subsequent works of Material Supply or Manufacturing until receiving Code1/Code2 or No Code from PURCHASER. Vendor/Sub-Contractor shall resubmit the document with the same revision within 6 working days after receiving comments				
No Code	<input type="checkbox"/> No Code (Only for "For Information" Documents and "As Built DWGs") Document has been submitted for PURCHASER's Information (I). Considering completeness and correctness of document content is in Vendor/Sub-Contractor's responsibility.				
The above checking result by EIED shall in no way relieve Vendor of any liability, obligation and responsibility out of the purchase order and the mutual agreement in writing.					
DATE : DEPT : Signature :					
CV	PI	EL	IN	ME	MA
ST	BU	PR	SA	HV	TL

01	06-FEB-2026	IF1	D.SH	F.T	A.M
00	09-DEC-2025	IF1	D.SH	F.T	A.M
REV.	DATE (DD.MM.YY)	Purpose of Issue	Prepared	Checked	Approved
 		Gachsan Polymer Industries Company HDPE Plant		 	
PO No.: GPIC-PT-MA-PO-000-3029					
DRAWING TITLE: Instruments Hookup Diagram and MTO					
DRAWING NO. VD-GPIC-MA-3029-0051			REV.	SHEET NO.	SIZE
			01	26 of 39	A3

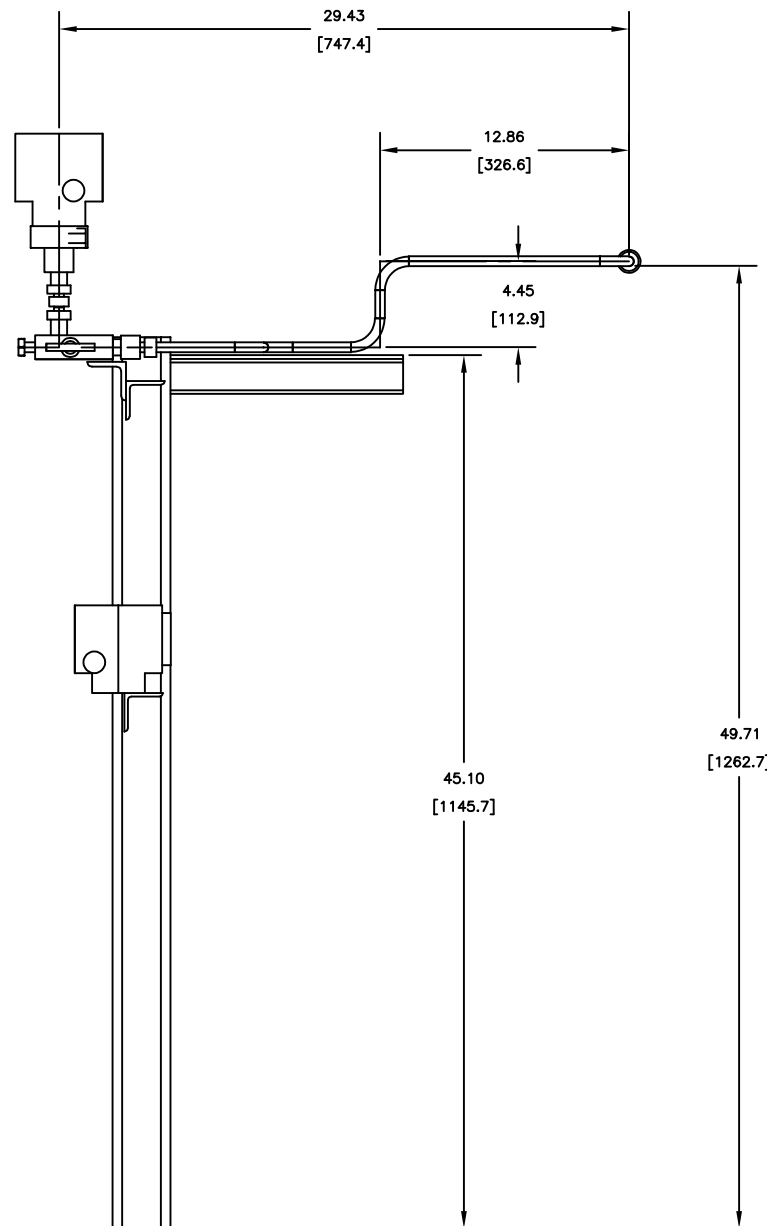
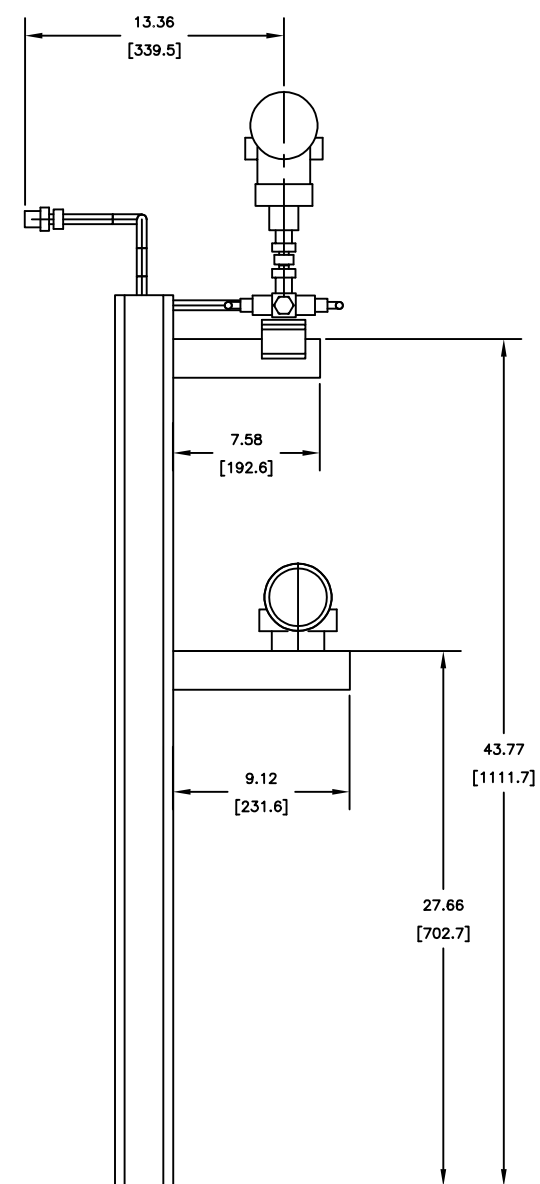
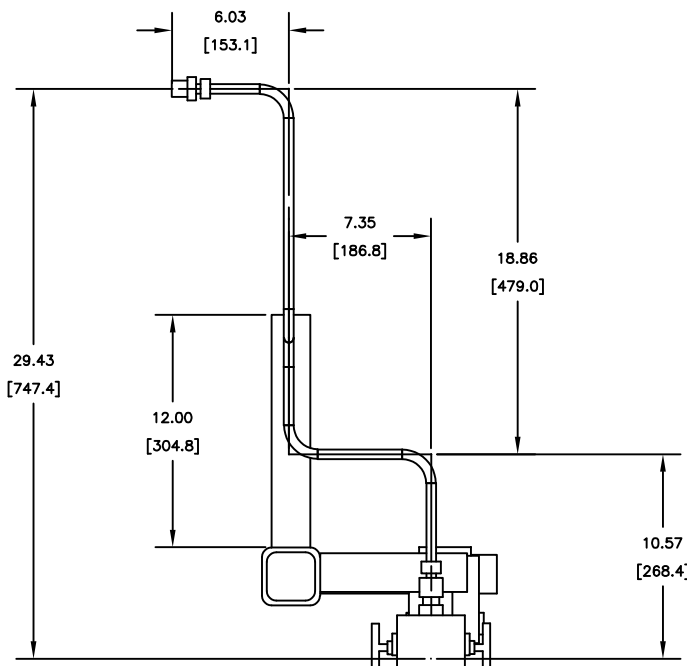

BILL OF MATERIALS				
PIPE				
ID	QTY	ND	DESCRIPTION	
1	2'-2"	1/2"	TUBING, ASTM A269, SEAMLESS -- 316SS	0.065" THK
FITTINGS				
ID	QTY	ND	DESCRIPTION	
2	5	1/2"	BEND 90 5R, TUBING, ASTM A269, 316SS	
3	1	1/2"	PLUG, HEX HEAD, MPT, ASME B16.11	
4	1	3/4"x1/2"	Male Connector 3/4" NPT(M) x 1/2" T	
VALVES				
ID	QTY	ND	DESCRIPTION	
5	1	1/2"	2-Way-Manifold	

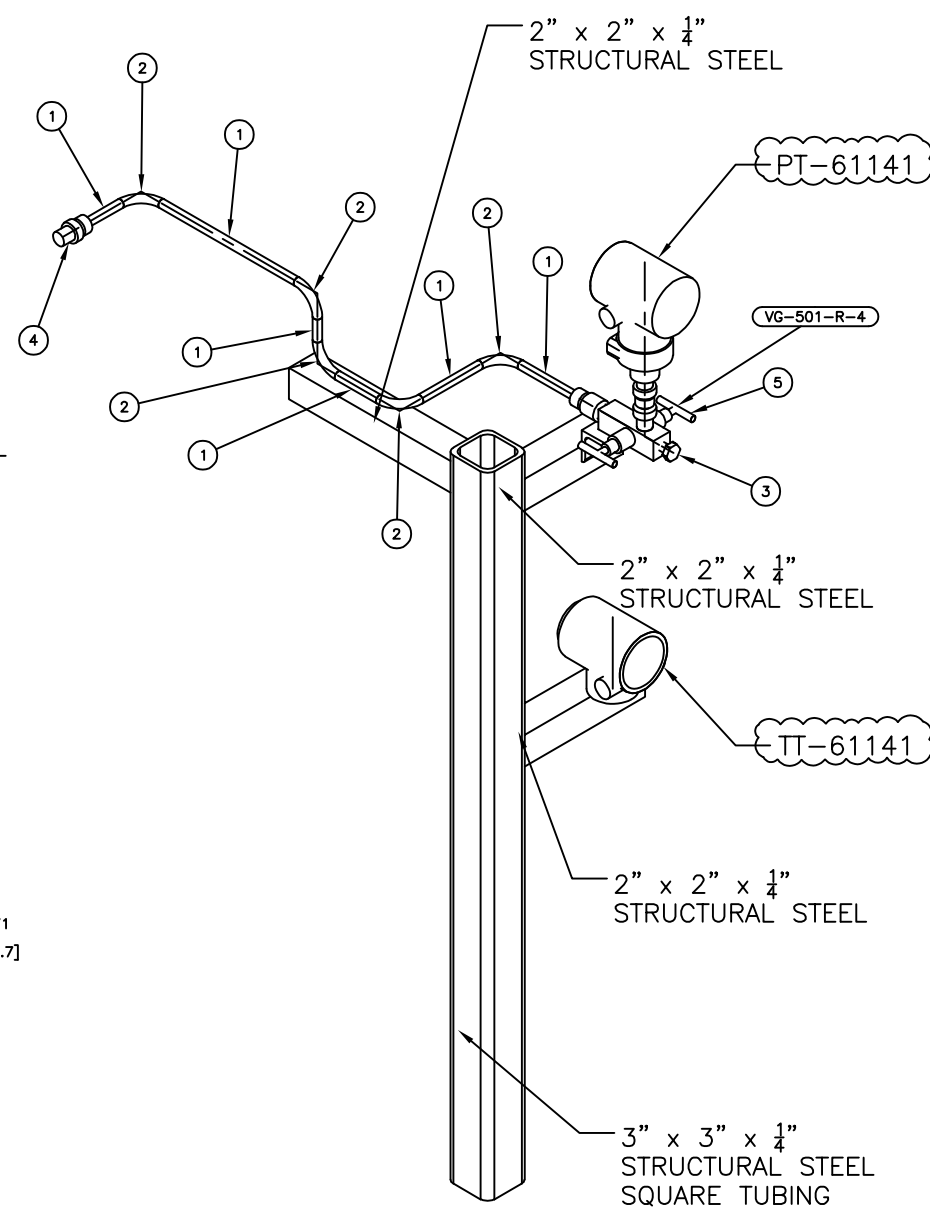

Code1	<input type="checkbox"/> No Comment/ Approved (Applicable Only for "FOR REVIEW" and "For Approval" Documents) No comment and the document are released for Manufacturing
Code2	<input type="checkbox"/> No Comment/ Approved with Note(s) Vendor/Sub-Contractor shall correct, revise and resubmit the document. The document is released for Manufacturing if changes incorporated.
Code3	<input type="checkbox"/> Commented Vendor/Sub-Contractor shall correct, revise and resubmit the document by the date specified. The document shall be revised under the Status of "R: Revised Issue". All corrected documents shall be resubmitted before starting the Manufacturing Process
Code4	<input type="checkbox"/> Not Accepted (Rejected) Vendor/Sub-Contractor shall re-work/re-design/re-specify the contents of the document according to the comments/reasons for rejection. All corrected documents shall be resubmitted before starting the manufacturing. Vendor/Sub-Contractor shall not proceed with subsequent works of Material Supply or Manufacturing until receiving Code1/Code2 or No Code from PURCHASER. Vendor/Sub-Contractor shall resubmit the document with the same revision within 6 working days after receiving comments
No Code	<input type="checkbox"/> No Code (Only for "For Information" Documents and "As Built DWGs") Document has been submitted for PURCHASER'S Information (I). Considering completeness and correctness of document content is in Vendor/Sub-Contractor's responsibility. The above checking result by EIED shall in no way relieve Vendor of any liability, obligation and responsibility out of the purchase order and the mutual agreement in writing
DATE : DEPT : Signature :	
CV	PI
ST	BU
EL	IN
PR	SA
ME	HV
MA	TL

01	08-FEB-2026	IFI	D-SH	F-T	A-M
00	08-DEC-2025	IFI	D-SH	F-T	A-M
REV.	DATE (DD-MMM-YY)	Purpose of Issue	Prepared	Checked	Approved
		Gachsaran Polymer Industries Company HDPE Plant			
PO No.: GPIC-PT-MA-PO-000-3029					SCALE: 1:1
DRAWING TITLE: Instruments Hookup Diagram and MTO					
DRAWING NO. VD-GPIC-MA-3029-0051			REV. 01	SHEET NO. 27 of 39	SIZE A3

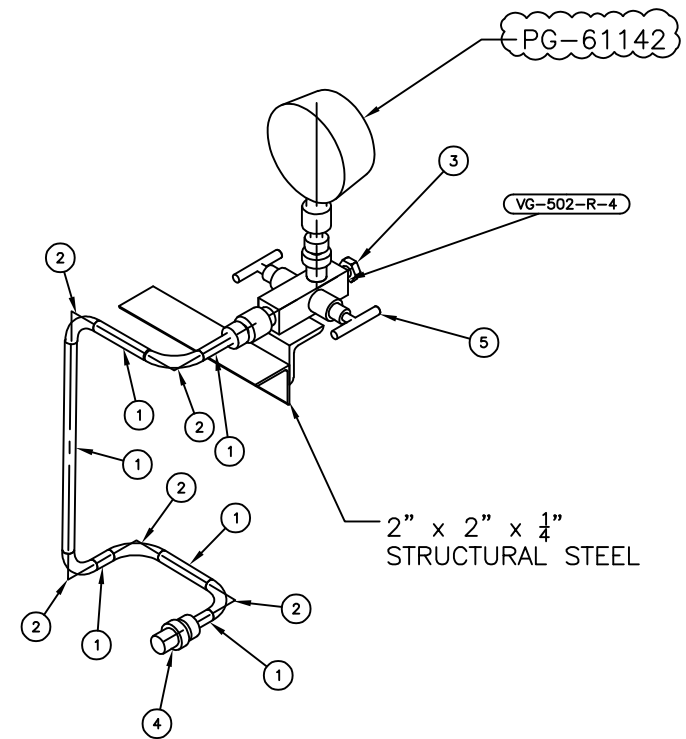
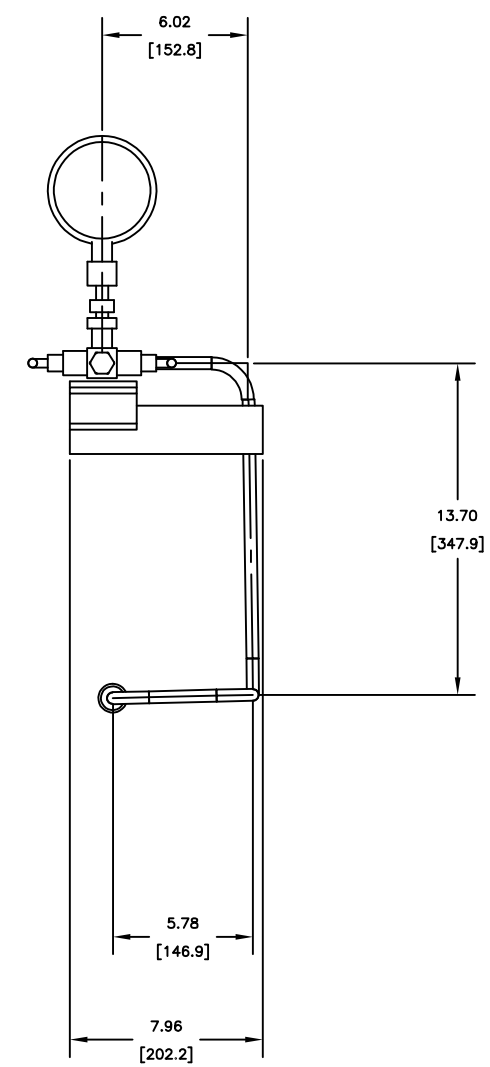
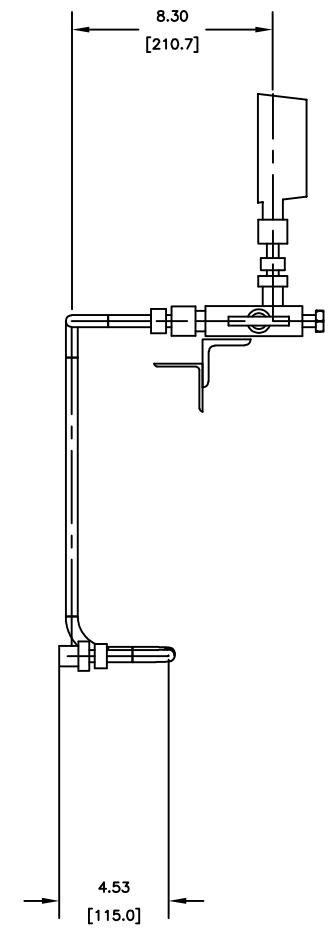
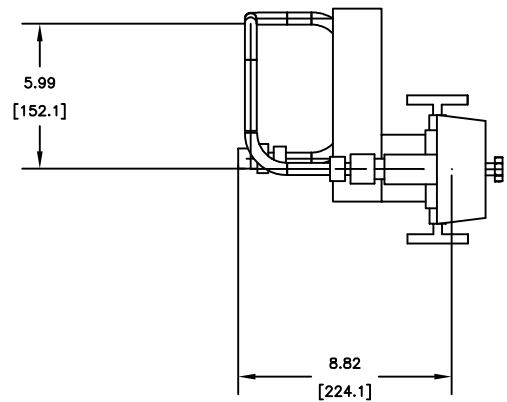

BILL OF MATERIALS					
PIPE					
ID	QTY	ND	DESCRIPTION		
1	1'-8	15/16"	1/2"	TUBING, ASTM A269, SEAMLESS - 316SS	0.065" THK
FITTINGS					
ID	QTY	ND	DESCRIPTION		
2	5	1/2"	BEND 90 5R, TUBING, ASTM A269, 316SS		
3	1	1/2"	PLUG, HEX HEAD, MPT, ASME B16.11		
4	1	3/4"x1/2"	Male Connector 3/4" NPT(M) x 1/2" T		
VALVES					
ID	QTY	ND	DESCRIPTION		
5	1	1/2"	2-Way-Manifold		

Code1	<input type="checkbox"/> No Comment/ Approved (Applicable Only for "FOR REVIEW" and "For Approval" Documents) No comment and the document are released for Manufacturing				
Code2	<input type="checkbox"/> No Comment/ Approved with Note(s) Vendor/Sub-Contractor shall correct, revise and resubmit the document. The document is released for Manufacturing if changes incorporated.				
Code3	<input type="checkbox"/> Commented Vendor/Sub-Contractor shall correct, revise and resubmit the document by the date specified. The document shall be reissued under the Status of "R: Revised Issue". All corrected documents shall be resubmitted before starting the Manufacturing Process				
Code4	<input type="checkbox"/> Not Accepted (Rejected) Vendor/Sub-Contractor shall re-work/re-design/re-specify the contents of the document according to the comments/reasons for rejection. All corrected documents shall be resubmitted before starting the manufacturing. Vendor/Sub-Contractor shall not proceed with subsequent works of Material Supply or Manufacturing until receiving Code1/Code2 or No Code from PURCHASER. Vendor/Sub-Contractor shall resubmit the document with the same revision within 6 working days after receiving comments				
No Code	<input type="checkbox"/> No Code (Only for "For Information" Documents and "As Built DWGs") Document has been submitted for PURCHASER'S Information (I). Consistency, completeness and correctness of document content is in Vendor/Sub-Contractor's responsibility. The above checking result by EIED shall in no way relieve Vendor of any liability, obligation and responsibility out of the purchase order and the mutual agreement in writing				
DATE: _____					
DEPT: _____					
Signature: _____					
CV	PI	EL	IN	ME	MA
ST	BU	PR	SA	HV	TL



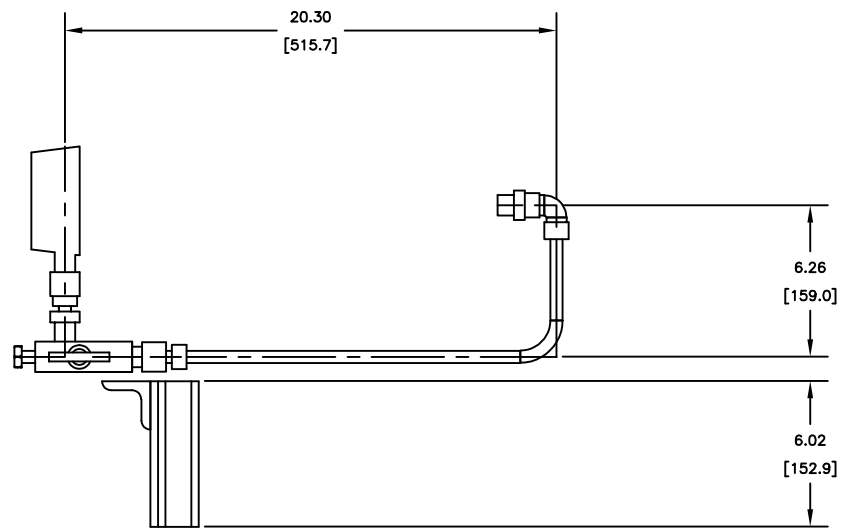
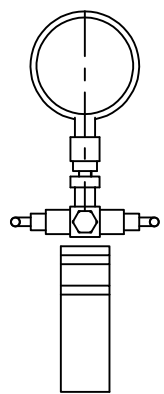
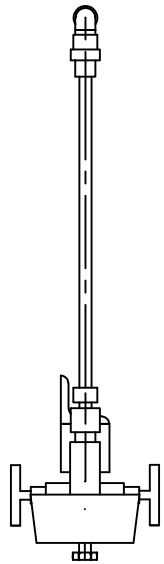

01	06-FEB-2026	HP	D.SH	F.T	A.M
00	06-DEC-2025	HP	D.SH	F.T	A.M
REV.	DATE (DD.MM.YY)	Purpose of Issue	Prepared	Checked	Approved
Gachsaran Polymer Industries Company HDPE Plant					
PO No.: GPIC-PT-MA-PO-000-3029					
DRAWING TITLE: Instruments Hookup Diagram and MTO					
DRAWING NO. VD-GPIC-MA-3029-3029-0051			REV.	SHEET NO.	SIZE
			01	28 of 39	A3

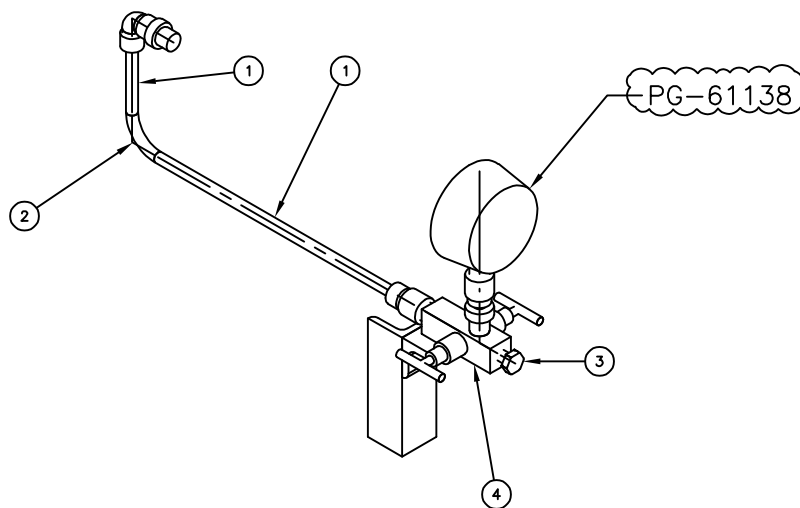

BILL OF MATERIALS				
PIPE				
ID	QTY	ND	DESCRIPTION	
1	1	1/2"	TUBING, ASTM A269, SEAMLESS - 316SS	0.065" THK
FITTINGS				
ID	QTY	ND	DESCRIPTION	
2	1	1/2"	BEND 90 5R, TUBING, ASTM A269, 316SS	
3	1	1/2"	PLUG, HEX HEAD, MPT, ASME B16.11	
VALVES				
ID	QTY	ND	DESCRIPTION	
4	1	1/2"	2-Way-Manifold	





Code1	<input type="checkbox"/> No Comment/ Approved (Applicable Only for "FOR REVIEW" and "For Approval" Documents) No comment and the document are released for Manufacturing				
Code2	<input type="checkbox"/> No Comment/ Approved with Note(s) Vendor/Sub-Contractor shall correct, revise and resubmit the document. The document is released for Manufacturing if changes incorporated.				
Code3	<input type="checkbox"/> Commented Vendor/Sub-Contractor shall correct, revise and resubmit the document by the date specified. The document shall be revised under the Status of "R: Revised Issue". All corrected documents shall be resubmitted before starting the Manufacturing Process				
Code4	<input type="checkbox"/> Not Accepted (Rejected) Vendor/Sub-Contractor shall re-work/re-design/re-specify the contents of the document according to the comments/reasons for rejection. All corrected documents shall be resubmitted before starting the manufacturing. Vendor/Sub-Contractor shall not proceed with subsequent works of Material Supply or Manufacturing until receiving Code1/Code2 or No Code from PURCHASER. Vendor/Sub-Contractor shall resubmit the document with the same revision within 6 working days after receiving comments				
No Code	<input type="checkbox"/> No Code (Only for "For Information" Documents and "As Built DWGs") Document has been submitted for PURCHASER's Information (FI). Consistency, completeness and correctness of document content is in Vendor/Sub-Contractor's responsibility.				
The above checking result by EIED shall in no way relieve Vendor of any liability, obligation and responsibility out of the purchase order and the mutual agreement in writing					
 DATE : DEPT : Signature :					
CV	PI	EL	IN	ME	MA
ST	BU	PR	SA	HV	TL

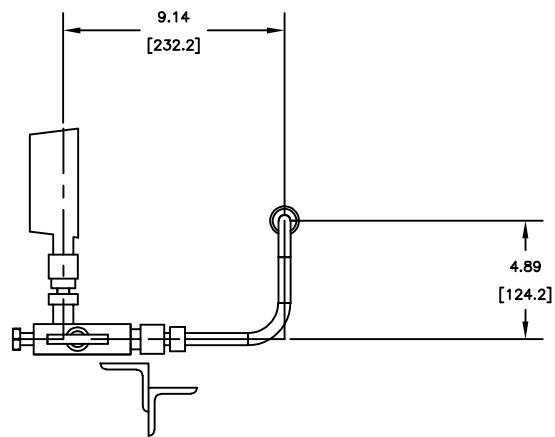
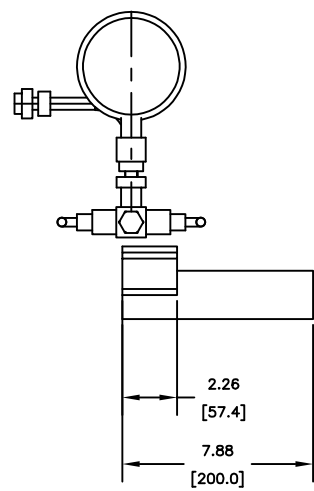
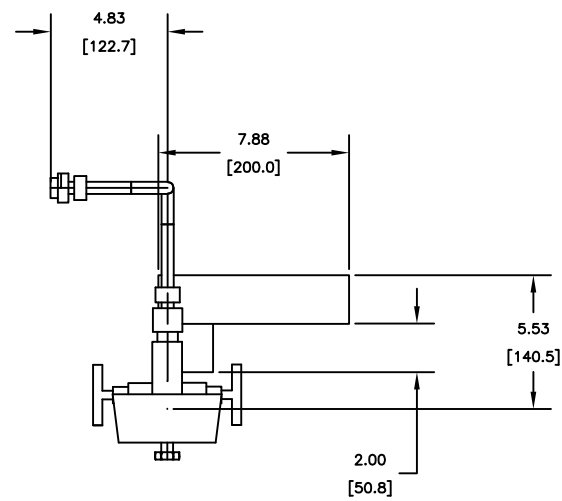

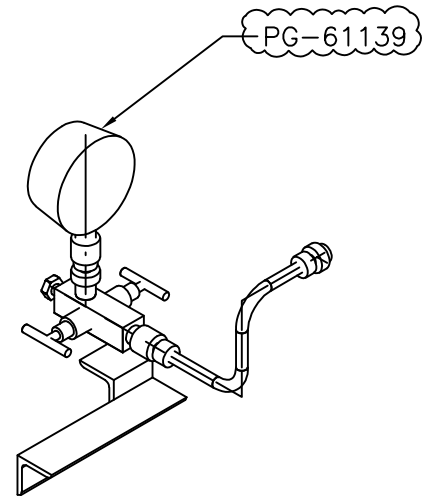

REV.	DATE (DD.MM.YY)	Purpose of Issue	Prepared	Checked	Approved
01	08-FEB-2020	IF1	D.SH	F.T	A.M
00	08-DEC-2015	IF1	D.SH	F.T	A.M
 		Gacharan Polymer Industries Company HDPE Plant			 
PO No.: GPIC-PT-MA-PO-000-3029					SCALE: 1:1
DRAWING TITLE: Instruments Hookup Diagram and MTO					
DRAWING NO. VD-GPIC-MA-3029-3029-0051			REV. 01	SHEET NO. 29 of 39	SIZE A3



BILL OF MATERIALS				
PIPE				
ID	QTY	ND	DESCRIPTION	
1	7	1/2"	TUBING, ASTM A269, SEAMLESS - 316SS	0.065" THK
FITTINGS				
ID	QTY	ND	DESCRIPTION	
2	1	1/2"xUndefin ed Size	MaleConnector 1/2 NPT(M) x 1/2"Tube	
3	2	1/2"	BEND 90 5R, TUBING, ASTM A269, 316SS	
4	1	1/2"	PLUG, HEX HEAD, MPT, ASME B16.11	
VALVES				
ID	QTY	ND	DESCRIPTION	
5	1	1/2"	2-Way-Manifold	





Code1	<input type="checkbox"/> No Comment/ Approved (Applicable Only for "FOR REVIEW" and "For Approval" Documents) No comment and the document are released for Manufacturing				
Code2	<input type="checkbox"/> No Comment/ Approved with Note(s) Vendor/Sub-Contractor shall correct, revise and resubmit the document. The document is released for Manufacturing if changes incorporated.				
Code3	<input type="checkbox"/> Commented Vendor/Sub-Contractor shall correct, revise and resubmit the document by the date specified. The document shall be revised under the Status of "R: Revised Issue". All corrected documents shall be resubmitted before starting the Manufacturing Process				
Code4	<input type="checkbox"/> Not Accepted (Rejected) Vendor/Sub-Contractor shall re-work/re-design/re-specify the contents of the document according to the comments/ reasons for rejection. All corrected documents shall be resubmitted before starting the manufacturing. Vendor Sub-Contractor shall not proceed with subsequent works of Material Supply or Manufacturing until receiving Code1/Code2 or No Code from PURCHASER. Vendor/Sub-Contractor shall resubmit the document with the same revision within 8 working days after receiving comments				
No Code	<input type="checkbox"/> No Code (Only for "For Information" Documents and "As Built DWG") Document has been submitted for PURCHASER'S information (FI). Consistency, completeness and correctness of document content is in Vendor/Sub-Contractor's responsibility.				
The above checking result by EIED shall in no way relieve Vendor of any liability, obligation and responsibility out of the purchase order and the mutual agreement in writing					
 DATE : DEPT : Signature :					
CY	PI	EL	IN	ME	MA
ST	BU	PR	SA	HV	TL

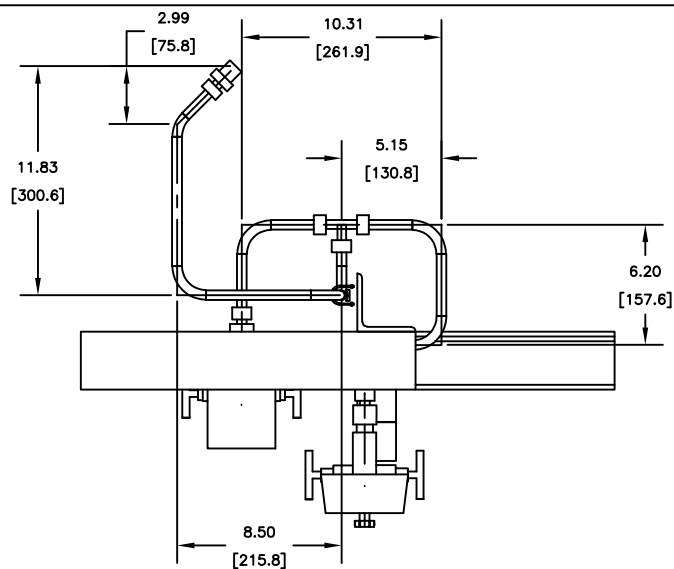

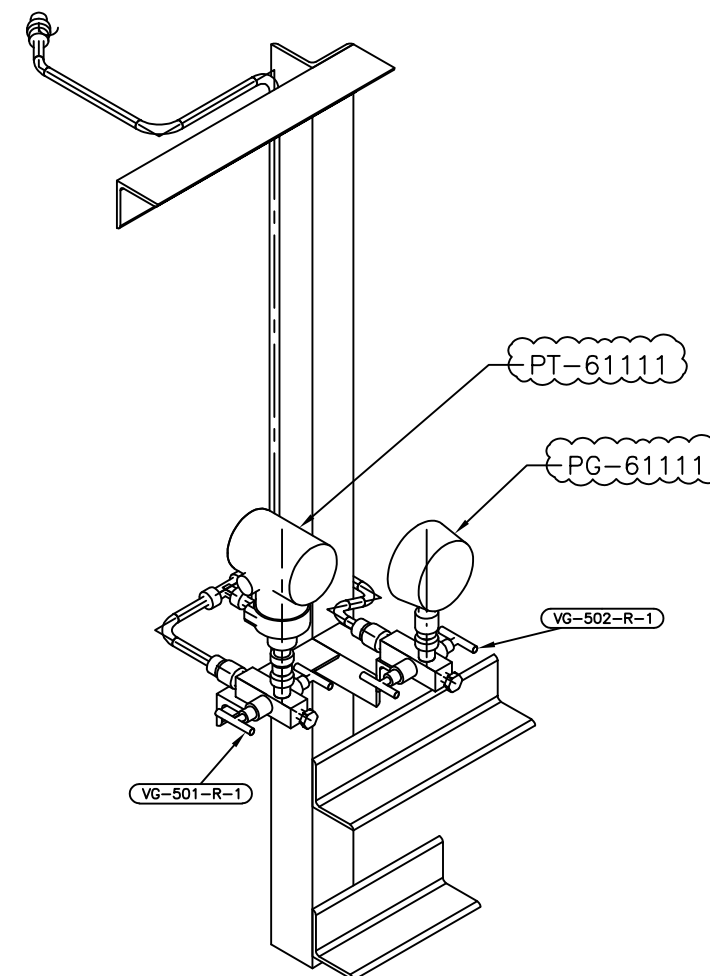
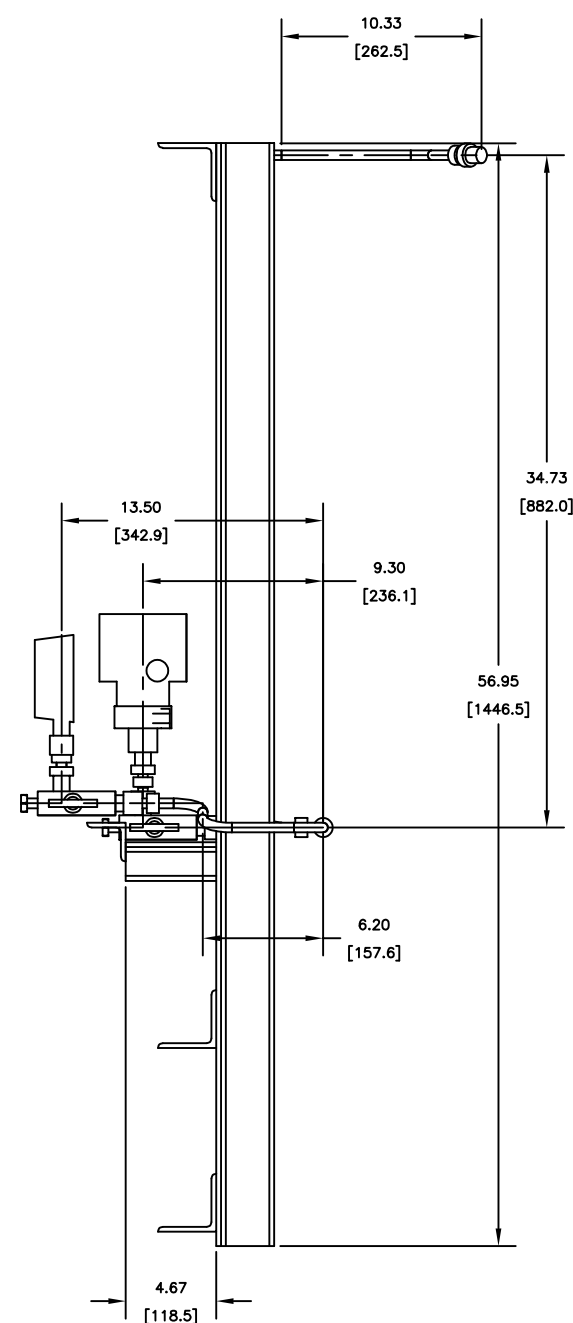
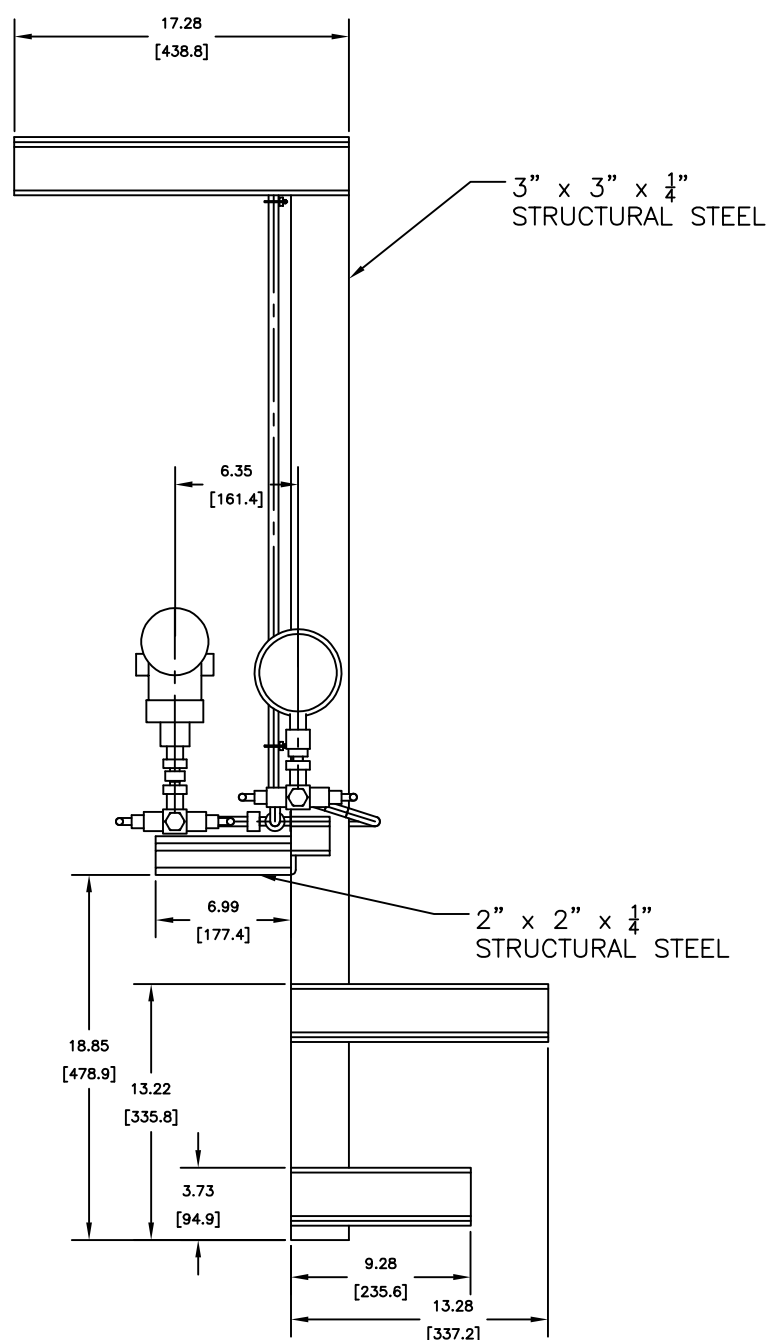

01	06-FEB-2026	IF1	D.SH	F.T	A.M
00	09-DEC-2025	IF1	D.SH	F.T	A.M
REV.	DATE (DD.MM.YY)	Purpose of Issue	Prepared	Checked	Approved
 		Gachisaran Polymer Industries Company HDPE Plant		 	
PO No.: GPIC-PT-MA-PO-000-3029					
DRAWING TITLE: Instruments Hookup Diagram and MTO					
DRAWING NO. VD-GPIC-MA-3029-3029-0051			REV.	SHEET NO.	SIZE
			01	30 of 39	A3



BILL OF MATERIALS				
PIPE				
ID	QTY	ND	DESCRIPTION	
1	5'-0 7/8"	1/2"	TUBING, ASTM A269, SEAMLESS - 316SS	0.065" THK
FITTINGS				
ID	QTY	ND	DESCRIPTION	
2	1	1/2"	BEND 45 5R, TUBING, ASTM A269, 316SS	
3	7	1/2"	BEND 90 5R, TUBING, ASTM A269, 316SS	
4	2	1/2"	PLUG, HEX HEAD, MPT, ASME B16.11	
5	1	3/4"x1/2"	Male Connector 3/4" NPT(M) x 1/2" T	
6	1	1/2"	Union_TEE_1/4" to 1"	
VALVES				
ID	QTY	ND	DESCRIPTION	
7	2	1/2"	2-Way-Manifold	
PIPE SUPPORTS				
ID	QTY	ND	DESCRIPTION	
8	2	1/2"	U-clamp	



Code1	<input type="checkbox"/> No Comment/ Approved (Applicable Only for "FOR REVIEW" and "For Approval" Documents) No comment and the document are released for Manufacturing				
Code2	<input type="checkbox"/> No Comment/ Approved with Note(s) Vendor/Sub-Contractor shall correct, revise and resubmit the document. The document is released for Manufacturing if changes incorporated.				
Code3	<input type="checkbox"/> Commented Vendor/Sub-Contractor shall correct, revise and resubmit the document by the date specified. The document shall be revised under the Status of "R: Revised Issue". All corrected documents shall be resubmitted before starting the Manufacturing Process				
Code4	<input type="checkbox"/> Not Accepted (Rejected) Vendor/Sub-Contractor shall re-work/re-design/re-specify the contents of the document according to the comments/reasons for rejection. All corrected documents shall be resubmitted before starting the manufacturing. Vendor/Sub-Contractor shall not proceed with subsequent works of Material Supply or Manufacturing until receiving Code1/Code2 or No Code from PURCHASER. Vendor/Sub-Contractor shall resubmit the document with the same revision within 6 working days after receiving comments				
No Code	<input type="checkbox"/> No Code (Only for "For Information" Documents and "As Built DWGs") Document has been submitted for PURCHASER'S information (FI). Consistency, completeness and correctness of document content is in Vendor/Sub-Contractor's responsibility.				
The above checking result by EIED shall in no way relieve Vendor of any liability, obligation and responsibility out of the purchase order and the mutual agreement in writing					
					
DATE: _____					
DEPT: _____					
Signature: _____					
CV	PI	EL	IN	ME	MA
ST	BU	FR	SA	HV	TL

01	08-FEB-2026	IF1	D.SH	F.T	A.M
00	08-DEC-2025	IF1	D.SH	F.T	A.M
REV.	DATE (DD.MM.YY)	Purpose of Issue	Prepared	Checked	Approved
 		Gachsaran Polymer Industries Company HDPE Plant		 	
PO No.: GPIC-PT-MA-PO-000-3029					
DRAWING TITLE: Instruments Hookup Diagram and MTO					
DRAWING NO. VD-GPIC-MA-3029-3029-0051			REV.	SHEET NO.	SIZE
			01	31 of 39	A3

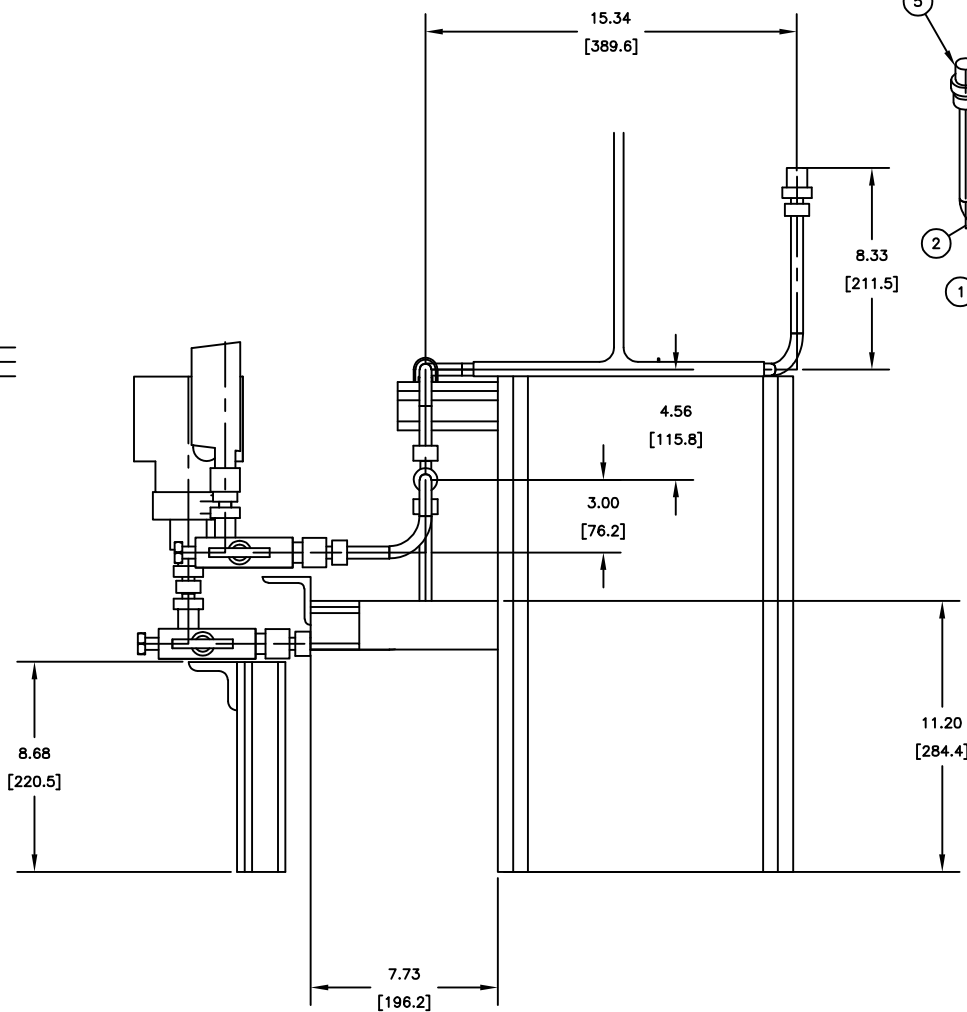
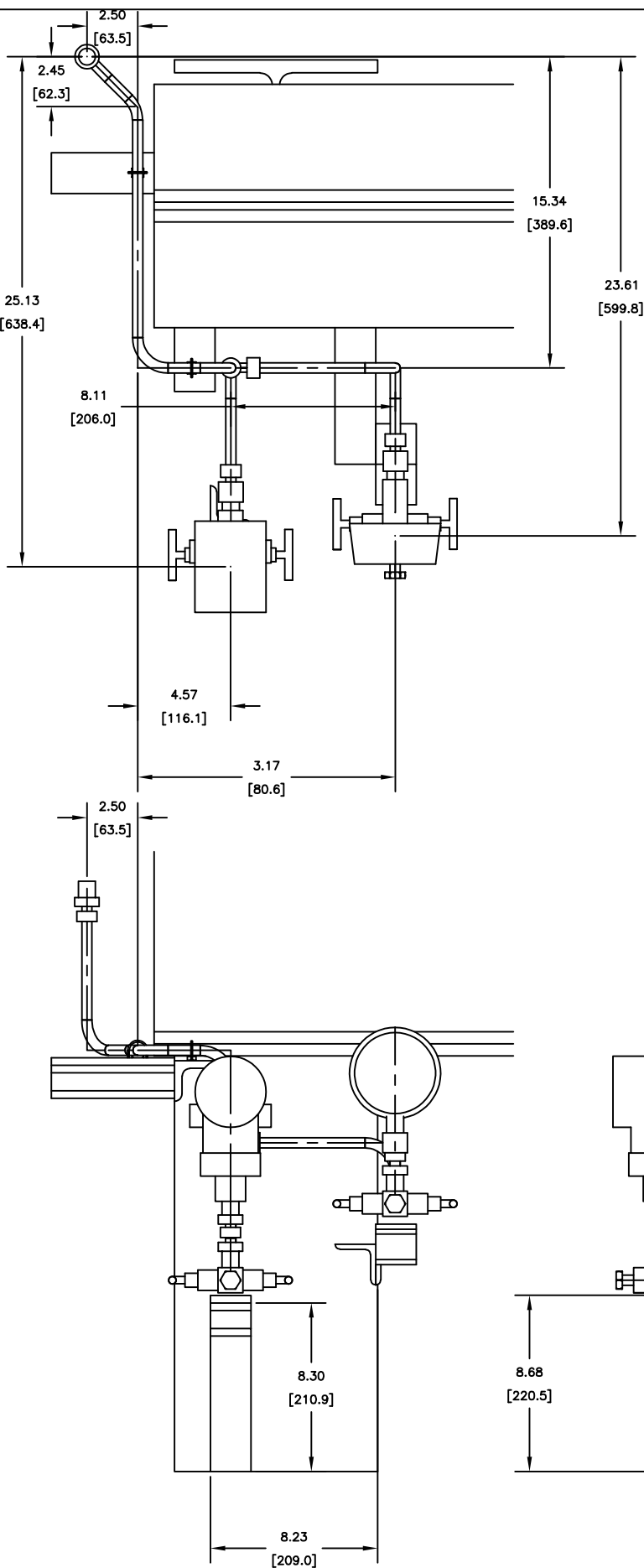

BILL OF MATERIALS				
PIPE				
ID	QTY	ND	DESCRIPTION	
1	3'-0	13/16"	TUBING, ASTM A269, SEAMLESS -- 316SS	0.065" THK
FITTINGS				
ID	QTY	ND	DESCRIPTION	
2	6	1/2"	BEND 90 5R, TUBING, ASTM A269, 316SS	
3	1	1/2"	BEND 45 5R, TUBING, ASTM A269, 316SS	
4	2	1/2"	PLUG, HEX HEAD, MPT, ASME B16.11	
5	1	3/4"x1/2"	Male Connector 3/4" NPT(M) x 1/2" T	
6	1	1/2"	Union_TEE_1/4" to 1"	
VALVES				
ID	QTY	ND	DESCRIPTION	
7	2	1/2"	2-Way-Manifold	
PIPE SUPPORTS				
ID	QTY	ND	DESCRIPTION	
8	2	1/2"	U-clamp	

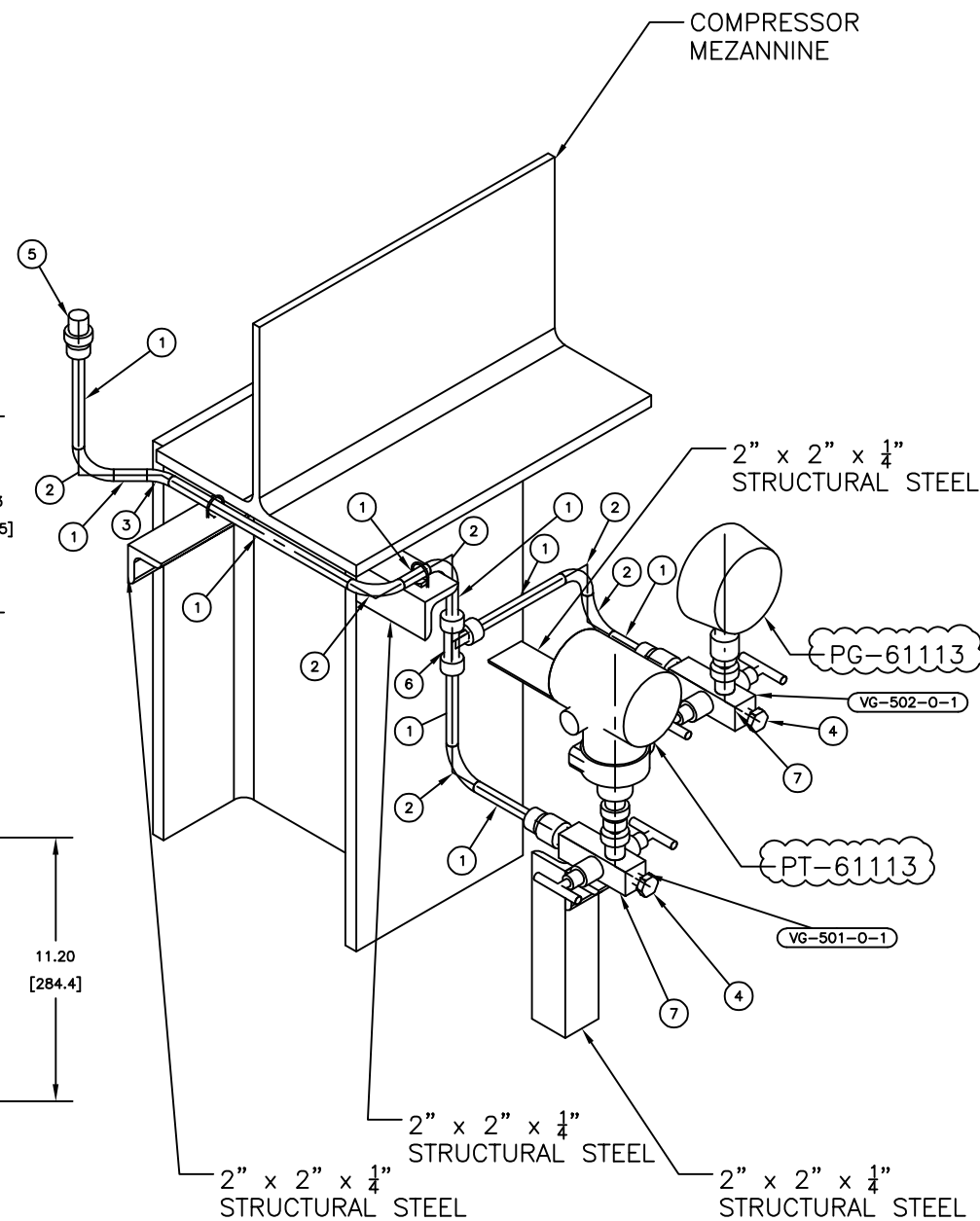

Code1	<input type="checkbox"/> No Comment/ Approved (Applicable Only for "FOR REVIEW" and "For Approval" Documents) No comment and the document are released for Manufacturing
Code2	<input type="checkbox"/> No Comment/ Approved with Note(s) Vendor/Sub-Contractor shall correct, revise and resubmit the document. The document is released for Manufacturing if changes incorporated.
Code3	<input type="checkbox"/> Commented Vendor/Sub-Contractor shall correct, revise and resubmit the document by the date specified. The document shall be revised under the Status of "Revised Issue". All corrected documents shall be resubmitted before starting the Manufacturing Process
Code4	<input type="checkbox"/> Not Accepted (Rejected) Vendor/Sub-Contractor shall re-work/re-design/re-specify the contents of the document according to the comments/reasons for rejection. All corrected documents shall be resubmitted before starting the manufacturing. Vendor/Sub-Contractor shall not proceed with subsequent works of Material Supply or Manufacturing until receiving Code1/Code2 or No Code from PURCHASER. Vendor/Sub-Contractor shall resubmit the document with the same revision within 6 working days after receiving comments
No Code	<input type="checkbox"/> No Code (Only for "For Information" Documents and "As Built DWGs") Document has been submitted for PURCHASER'S Information (FI). Consistency, completeness and correctness of document content is in Vendor/Sub-Contractor's responsibility.

The above checking result by EIED shall in no way relieve Vendor of any liability, obligation and responsibility out of the purchase order and the mutual agreement in writing

DATE: _____
DEPT: _____
Signature: _____

CV	PI	EL	IN	ME	MA
ST	BU	PR	SA	HV	TL

01	05-FEB-2026	IF1	D.SH	F.T	A.M
00	09-DEC-2025	IF1	D.SH	F.T	A.M
REV.	DATE (DD.MM.YY)	Purpose of Issue	Prepared	Checked	Approved

SCALE: 1:1

PO No.: GPIC-PT-MA-PO-000-3029
DRAWING TITLE: Instruments Hookup Diagram and MTO

DRAWING NO.	REV.	SHEET NO.	SIZE
VD-GPIC-MA-3029-3029-0051	01	32 of 39	A3

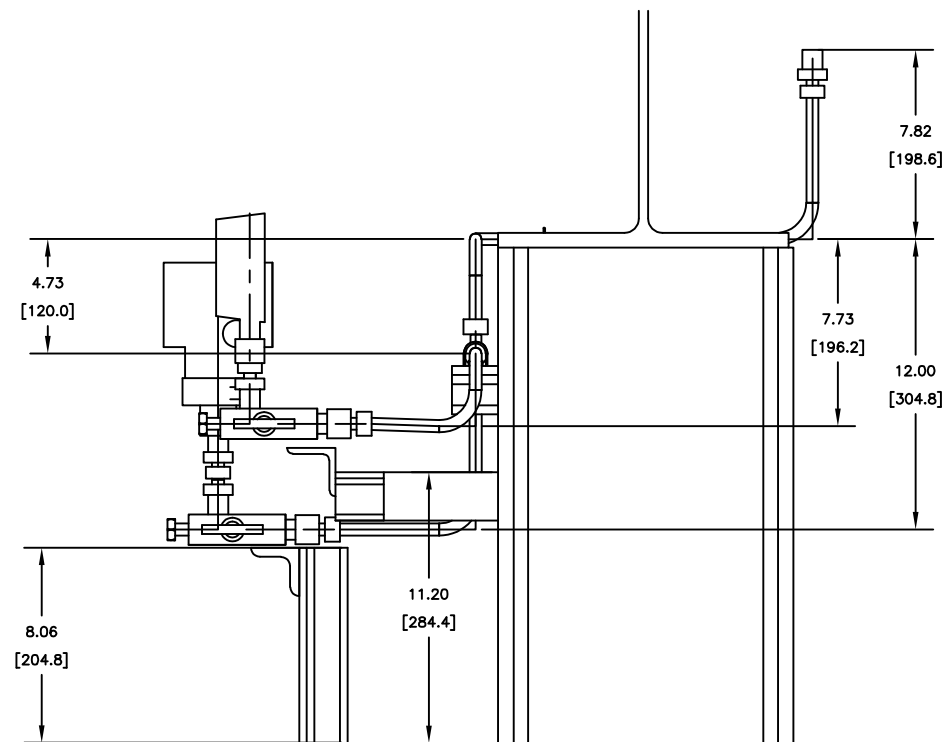
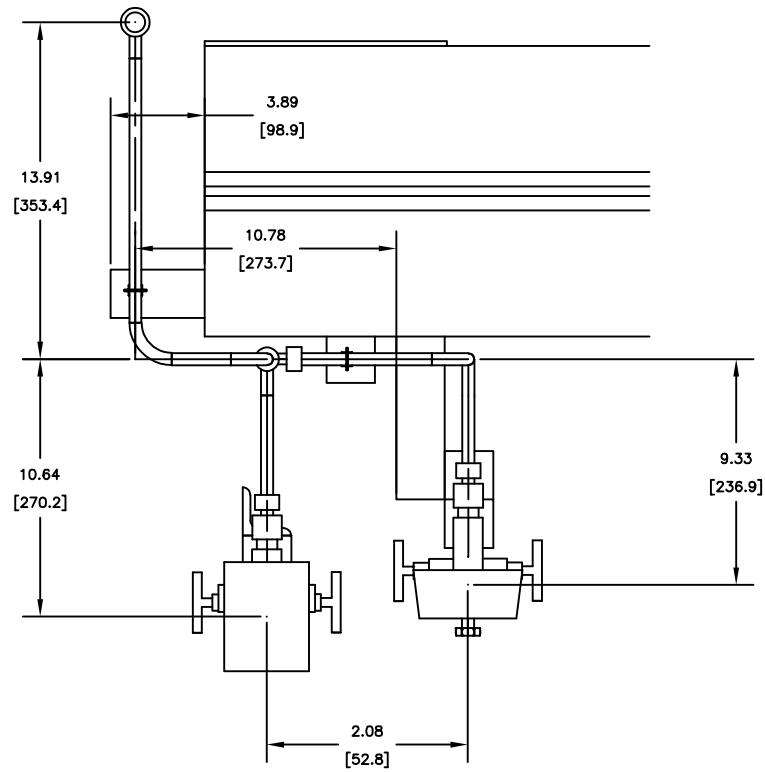

BILL OF MATERIALS				
PIPE				
ID	QTY	ND	DESCRIPTION	
1	3'-2 3/4"	1/2"	TUBING, ASTM A269, SEAMLESS - 316SS	0.065" THK
FITTINGS				
ID	QTY	ND	DESCRIPTION	
2	6	1/2"	BEND 90 5R, TUBING, ASTM A269, 316SS	
3	2	1/2"	PLUG, HEX HEAD, MPT, ASME B16.11	
4	1	3/4"x1/2"	Male Connector 3/4" NPT(M) x 1/2" T	
5	1	1/2"	Union_TEE_1/4" to 1"	
VALVES				
ID	QTY	ND	DESCRIPTION	
6	2	1/2"	2-Way-Manifold	
PIPE SUPPORTS				
ID	QTY	ND	DESCRIPTION	
7	2	1/2"	U-clamp	

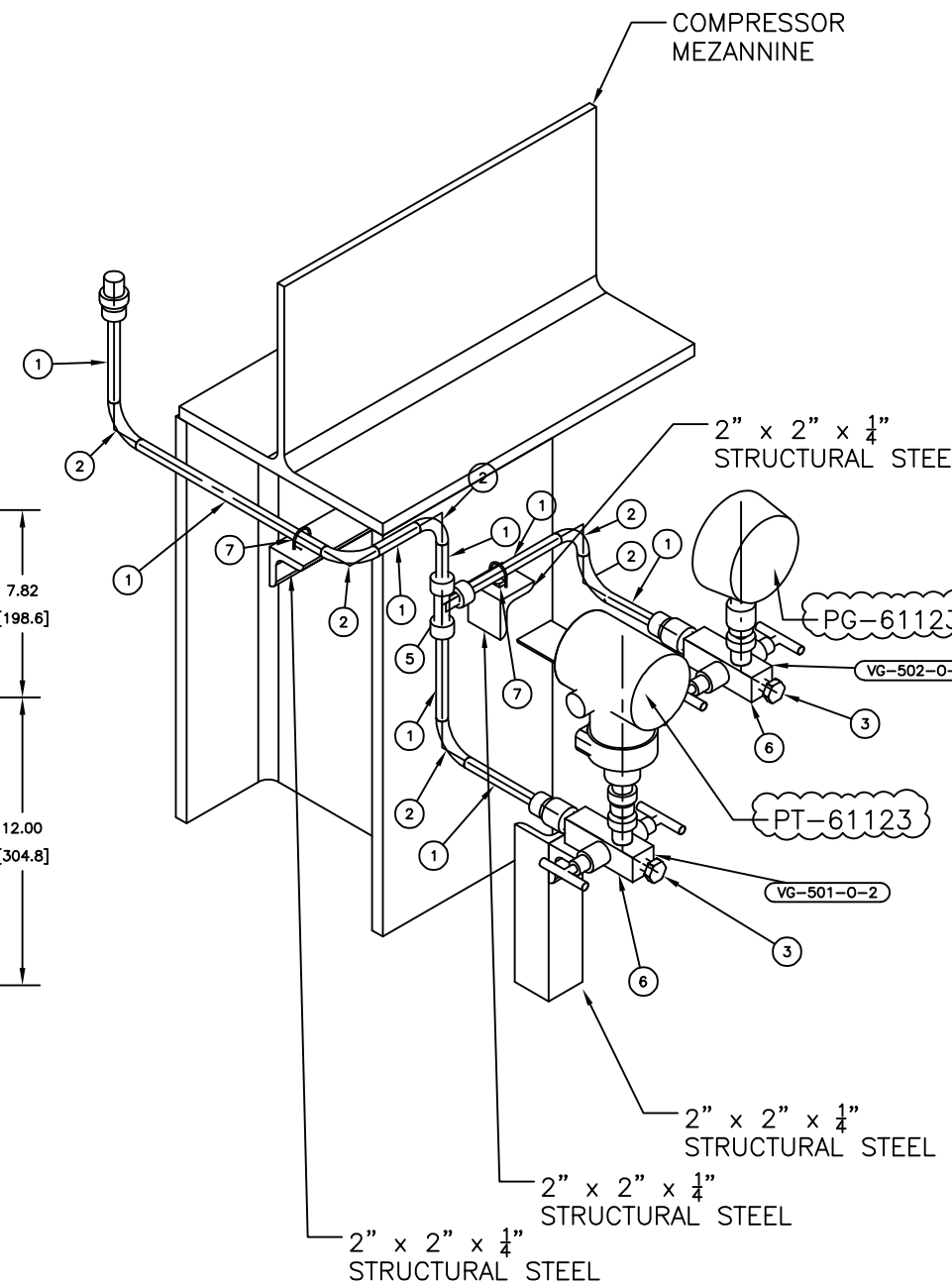

Code1	<input type="checkbox"/> No Comment/ Approved (Applicable Only for "FOR REVIEW" and "For Approval" Documents) No comment and the document are released for Manufacturing
Code2	<input type="checkbox"/> No Comment/ Approved with Note(s) Vendor/Sub-Contractor shall correct, revise and resubmit the document. The document is released for Manufacturing if changes incorporated.
Code3	<input type="checkbox"/> Commented Vendor/Sub-Contractor shall correct, revise and resubmit the document by the date specified. The document shall be revised under the Status of "To: Revised Issue". All corrected documents shall be resubmitted before starting the Manufacturing Process
Code4	<input type="checkbox"/> Not Accepted (Rejected) Vendor/Sub-Contractor shall re-work/re-design/re-specify the contents of the document according to the comments/reasons for rejection. All corrected documents shall be resubmitted before starting the manufacturing. Vendor/Sub-Contractor shall not proceed with subsequent works of Material Supply or Manufacturing until receiving Code1/Code2 or No Code from PURCHASER. Vendor/Sub-Contractor shall resubmit the document with the same revision within 6 working days after receiving comments
No Code	<input type="checkbox"/> No Code (Only for "For Information" Documents and "As Built DWGs") Document has been submitted for PURCHASER's Information (FI). Considering completeness and correctness of document content is in Vendor/Sub-Contractor's responsibility.

The above checking result by EIED shall in no way relieve Vendor of any liability, obligation and responsibility out of the purchase order and the mutual agreement in writing.

DATE :
DEPT :
Signature :

CV	FI	EL	IN	ME	MA
ST	BU	PR	SA	HV	TL

01	06-FEB-2026	IF1	D.SH	F.T	A.M
00	09-DEC-2025	IF1	D.SH	F.T	A.M
REV.	DATE (DD.MM.YY)	Purpose of Issue	Prepared	Checked	Approved

PO No.: GPIC-PT-MA-PO-000-3029
DRAWING TITLE: Instruments Hookup Diagram and MTO
SCALE: 1:1

DRAWING NO.	REV.	SHEET NO.	SIZE
VD-GPIC-MA-3029-3029-0051	01	33 of 39	A3

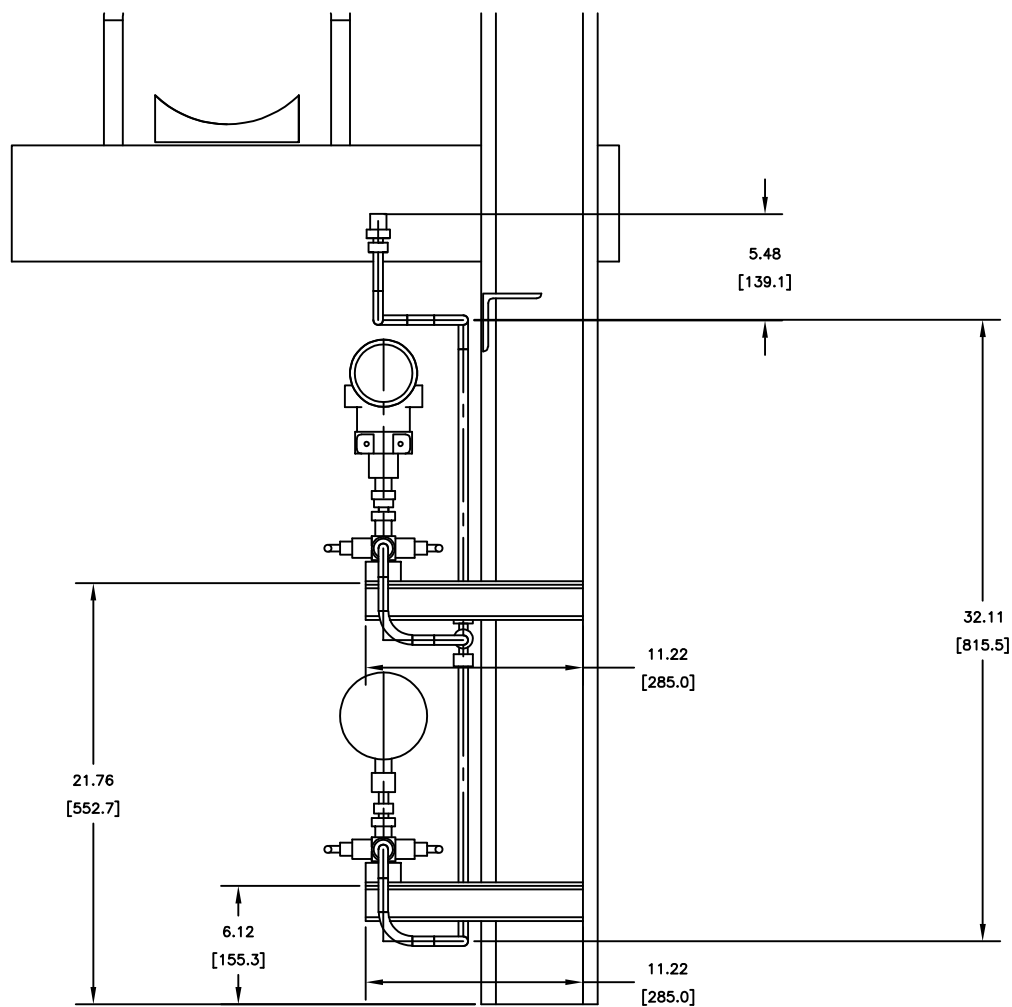
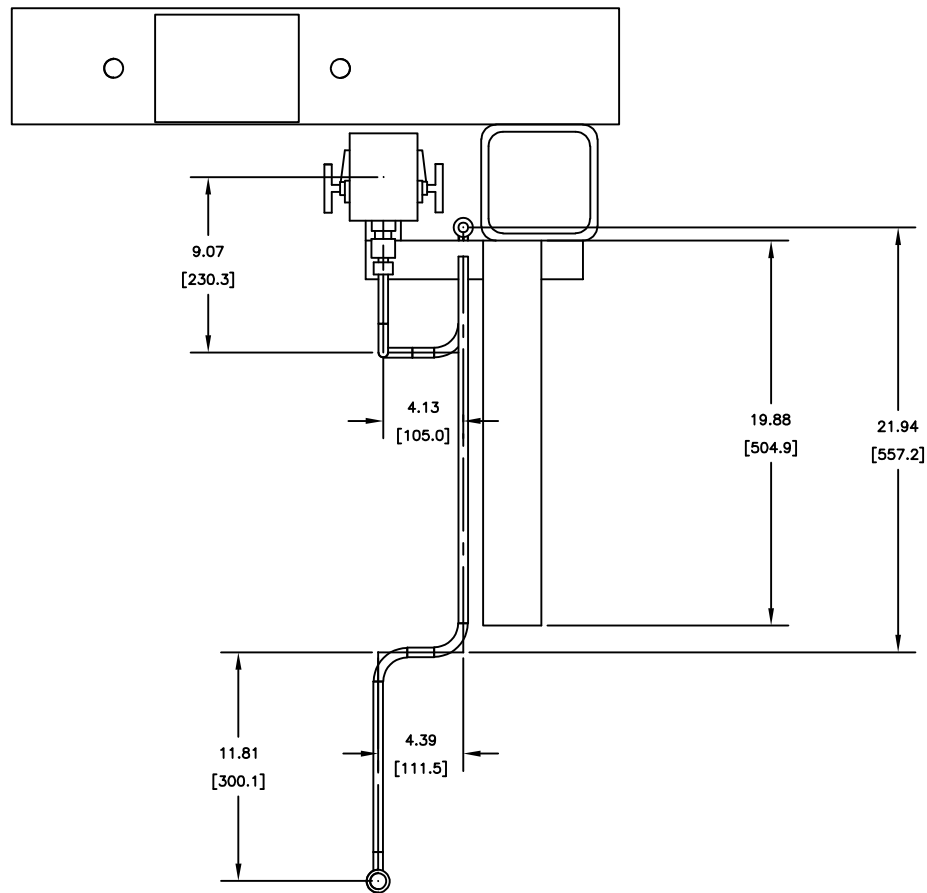

BILL OF MATERIALS				
PIPE				
ID	QTY	ND	DESCRIPTION	
1	6'-5 5/16"	1/2"	TUBING, ASTM A269, SEAMLESS - 316SS	0.065" THK
FITTINGS				
ID	QTY	ND	DESCRIPTION	
2	11	1/2"	BEND 90 5R, TUBING, ASTM A269, 316SS	
3	2	1/2"	PLUG, HEX HEAD, MPT, ASME B16.11	
4	1	3/4"x1/2"	Male Connector 3/4" NPT(M) x 1/2" T	
5	1	1/2"	Union_TEE_1/4" to 1"	
VALVES				
ID	QTY	ND	DESCRIPTION	
6	2	1/2"	2-Way-Manifold	
PIPE SUPPORTS				
ID	QTY	ND	DESCRIPTION	
7	1	10"	U-clamp	

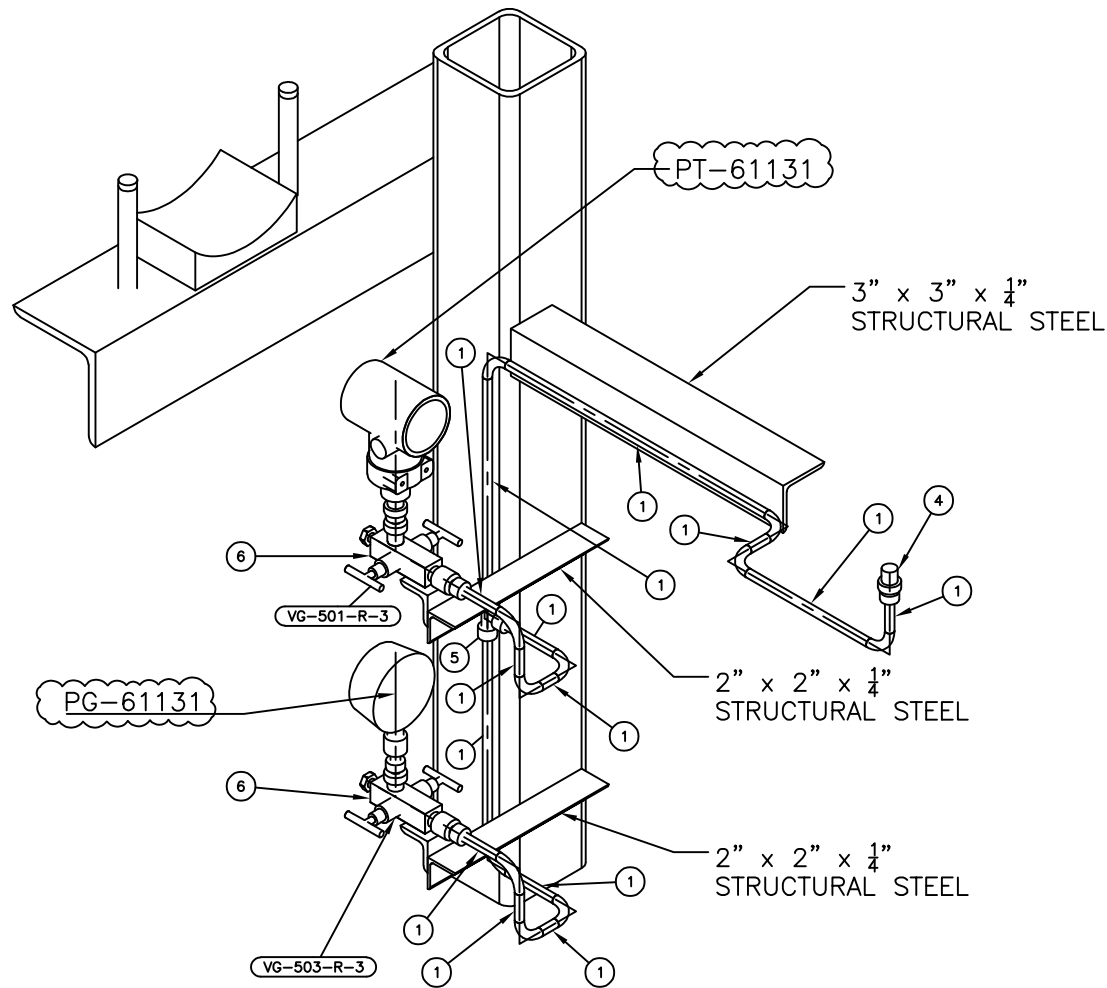

Code1	<input type="checkbox"/> No Comment/ Approved (Applicable Only for "FOR REVIEW" and "For Approval" Documents) No comment and the document are released for Manufacturing				
Code2	<input type="checkbox"/> No Comment/ Approved with Note(s) Vendor/Sub-Contractor shall correct, revise and resubmit the document. The document is released for Manufacturing if changes incorporated.				
Code3	<input type="checkbox"/> Commented Vendor/Sub-Contractor shall correct, revise and resubmit the document by the date specified. The document shall be revised under the Status of "To Revised Issue". All corrected documents shall be resubmitted before starting the Manufacturing Process				
Code4	<input type="checkbox"/> Not Accepted (Rejected) Vendor/Sub-Contractor shall re-work/re-design/re-specify the contents of the document according to the comments/reasons for rejection. All corrected documents shall be resubmitted before starting the manufacturing. Vendor/Sub-Contractor shall not proceed with subsequent works of Material Supply or Manufacturing until receiving Code1/Code2 or No Code from PURCHASER. Vendor/Sub-Contractor shall resubmit the document with the same revision within 6 working days after receiving comments				
No Code	<input type="checkbox"/> No Code (Only for "For Information" Documents and "As Built DWG") Document has been submitted for PURCHASER's Information (FI). Consistency, completeness and correctness of document content is in Vendor/Sub-Contractor's responsibility.				
The above checking result by EIED shall in no way relieve Vendor of any liability, obligation and responsibility out of the purchase order and the mutual agreement in writing					
DATE :					
DEPT:					
Signature :					
CV	PI	EL	IN	ME	MA
ST	BU	PR	SA	HV	TL

01	08-FEB-2020	IFI	D.SH	F.T	A.M
00	08-DEC-2025	IFI	D.SH	F.T	A.M
REV.	DATE (DD.MM.YY)	Purpose of Issue	Prepared	Checked	Approved
Gachsaran Polymer Industries Company					HOPE Plant
PO No.: GPIC-PT-MA-PO-000-3029					SCALE: 1:1
DRAWING TITLE:					
Instruments Hookup Diagram and MTO					
DRAWING NO.			REV.	SHEET NO.	SIZE
VD-GPIC-MA-3029-3029-0051			01	34 of 39	A3

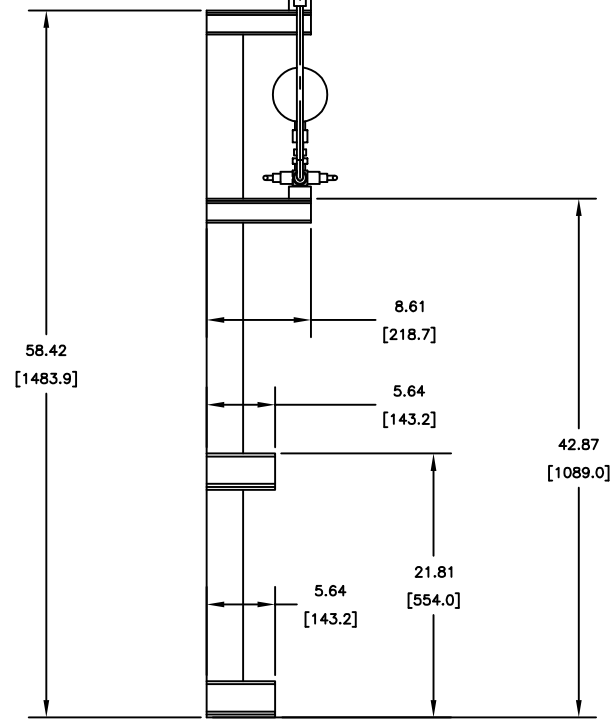
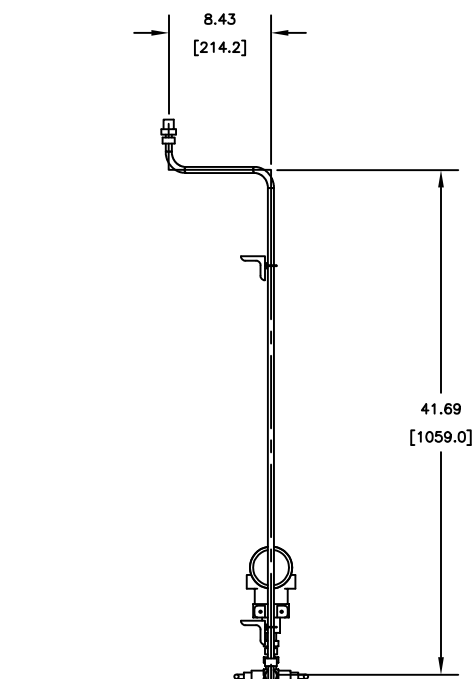
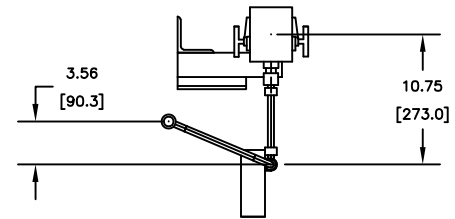
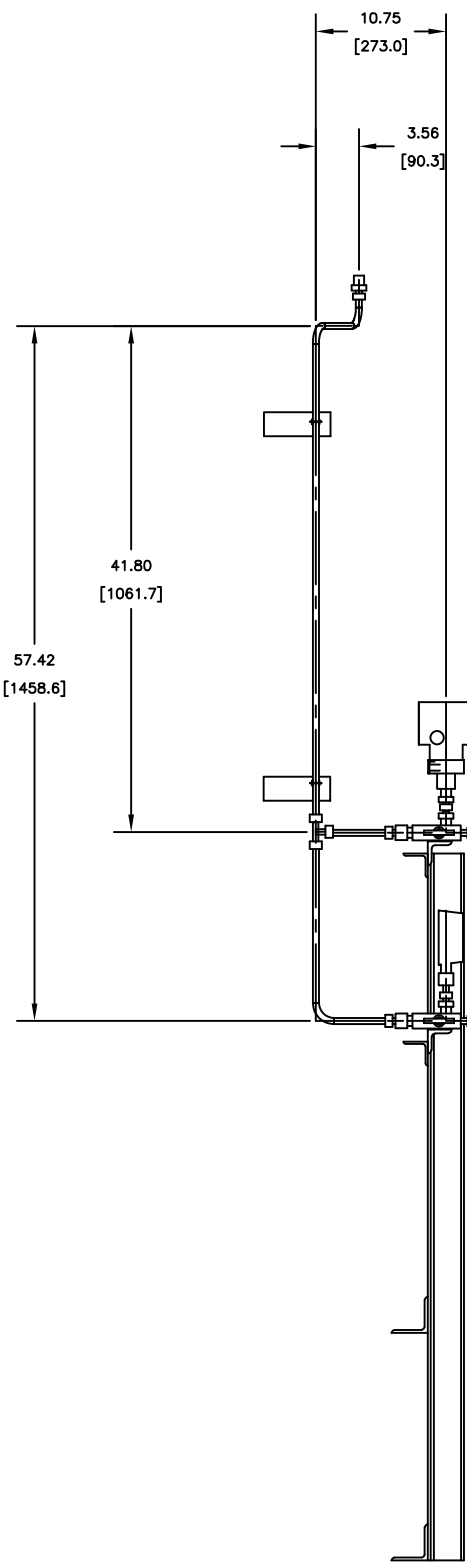

BILL OF MATERIALS			
PIPE			
ID	QTY	ND	DESCRIPTION
1	5'-9 1/8"	1/2"	TUBING, ASTM A269, SEAMLESS - 316SS
FITTINGS			
ID	QTY	ND	DESCRIPTION
2	3	1/2"	BEND 90 5R, TUBING, ASTM A269, 316SS
3	2	1/2"	PLUG, HEX HEAD, MPT, ASME B16.11
4	1	3/4"x1/2"	Male Connector 3/4" NPT(M) x 1/2" T
5	1	1/2"	Union_TEE_1/4" to 1"
VALVES			
ID	QTY	ND	DESCRIPTION
6	2	1/2"	2-Way-Manifold
PIPE SUPPORTS			
ID	QTY	ND	DESCRIPTION
7	2	1/2"	U-clamp

0.065" THK

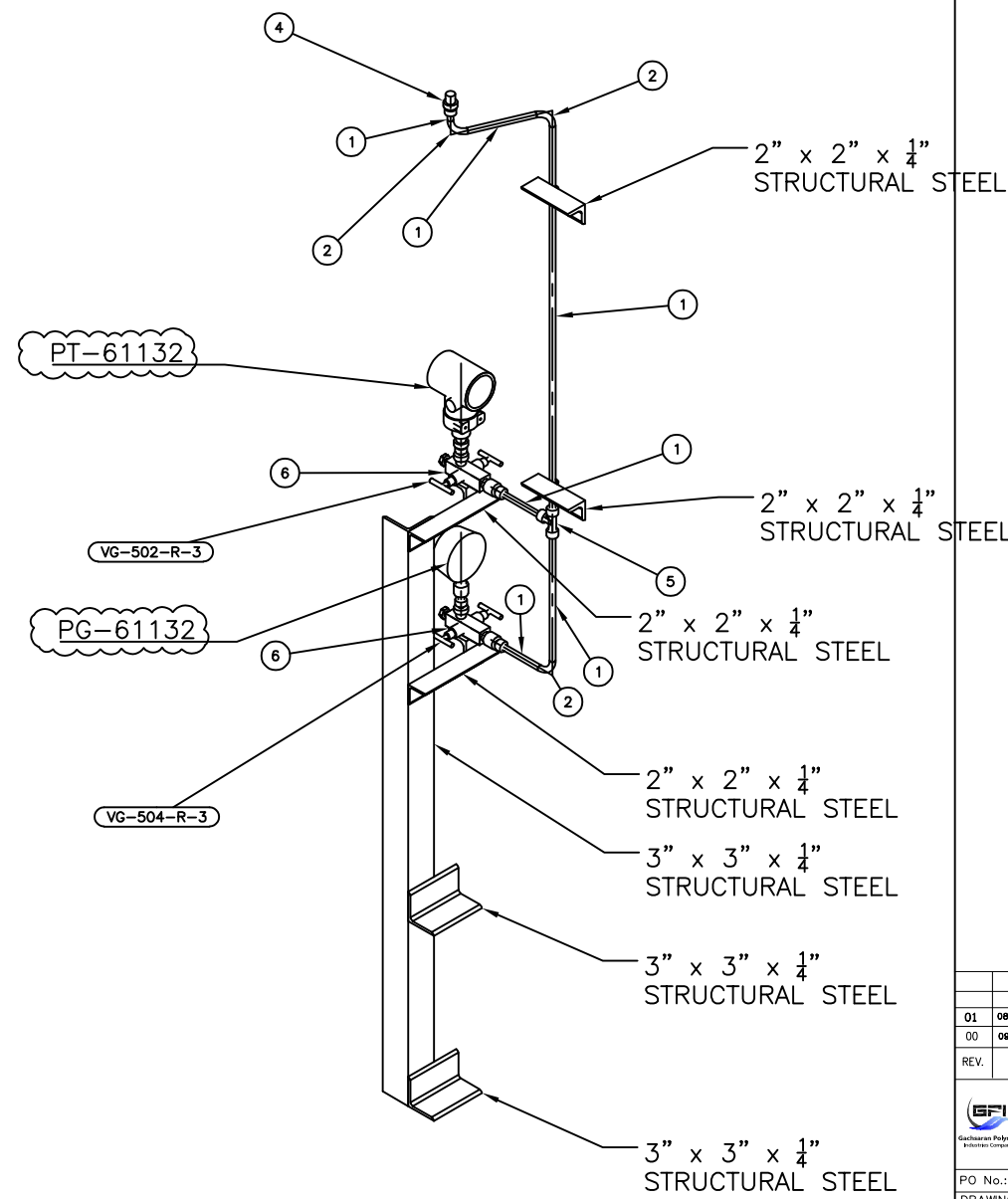

Code1	<input type="checkbox"/> No Comment/ Approved (Applicable Only for "FOR REVIEW" and "For Approval" Documents) No comment and the document are released for Manufacturing
Code2	<input type="checkbox"/> No Comment/ Approved with Note(s) Vendor/Sub-Contractor shall correct, revise and resubmit the document. The document is released for Manufacturing if changes incorporated.
Code3	<input type="checkbox"/> Commented Vendor/Sub-Contractor shall correct, revise and resubmit the document by the date specified. The document shall be revised under the Status of "R: Revised Issue". All corrected documents shall be resubmitted before starting the Manufacturing Process
Code4	<input type="checkbox"/> Not Accepted (Rejected) Vendor/Sub-Contractor shall re-work/re-design/re-specify the contents of the document according to the comments/reasons for rejection. All corrected documents shall be resubmitted before starting the manufacturing. Vendor/Sub-Contractor shall not proceed with subsequent works of Material Supply or Manufacturing until receiving Code1/Code2 or No Code from PURCHASER. Vendor/Sub-Contractor shall resubmit the document with the same revision within 6 working days after receiving comments
No Code	<input type="checkbox"/> No Code (Only for "For Information" Documents and "As Built DWGs") Document has been submitted for PURCHASER'S Information (FI). Consistency, completeness and correctness of document content is in Vendor/Sub-Contractor's responsibility.

The above checking result by EED shall in no way relieve Vendor of any liability, obligation and responsibility out of the purchase order and the mutual agreement in writing

EIED

DATE :
DEPT :
Signature :

CV	PI	EL	IN	ME	MA
ST	BU	PR	SA	HV	TL

01	08-FEB-2026	IFT	D-SH	F-T	A-M
00	08-DEC-2025	IFT	D-SH	F-T	A-M
REV.	DATE (DD.MM.YY)	Purpose of Issue	Prepared	Checked	Approved

PO No.: GPIC-PT-MA-PO-000-3029
DRAWING TITLE: Instruments Hookup Diagram and MTO
SCALE: 1:1

DRAWING NO.	REV.	SHEET NO.	SIZE
VD-GPIC-MA-3029-3029-0051	01	35 of 39	A3

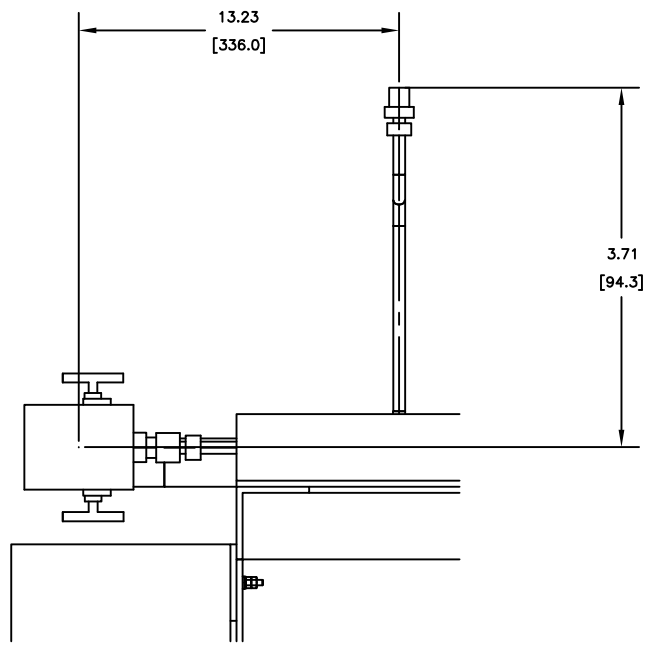

BILL OF MATERIALS			
PIPE			
ID	QTY	ND	DESCRIPTION
1	1'-4 7/16"	1/2"	TUBING, ASTM A269, SEAMLESS - 316SS
FITTINGS			
ID	QTY	ND	DESCRIPTION
2	2	1/2"	BEND 45 5R, TUBING, ASTM A269, 316SS
3	1	1/2"	BEND 90 5R, TUBING, ASTM A269, 316SS
4	1	1/2"	PLUG, HEX HEAD, MPT, ASME B16.11
VALVES			
ID	QTY	ND	DESCRIPTION
5	1	1/2"	2-Way-Manifold

0.065" THK

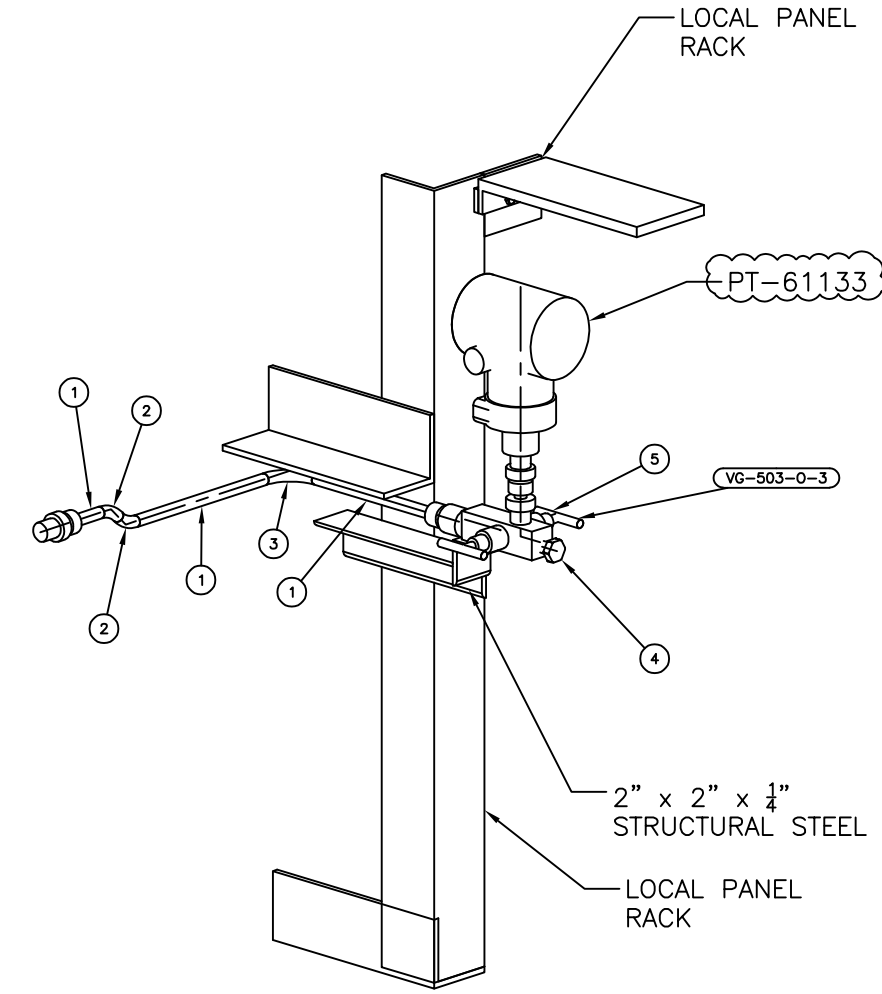
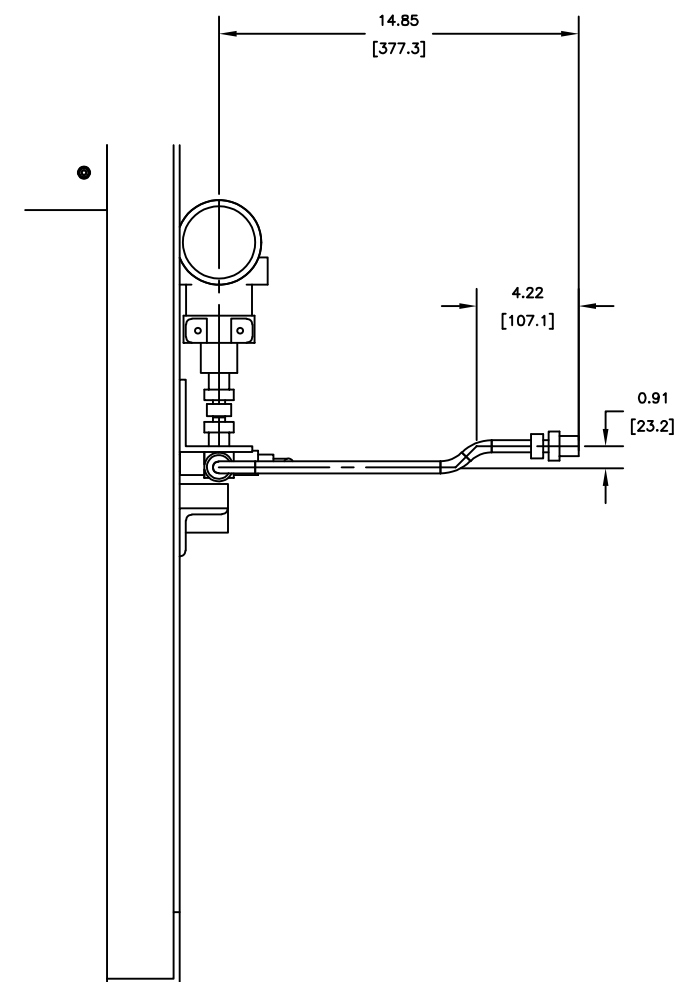
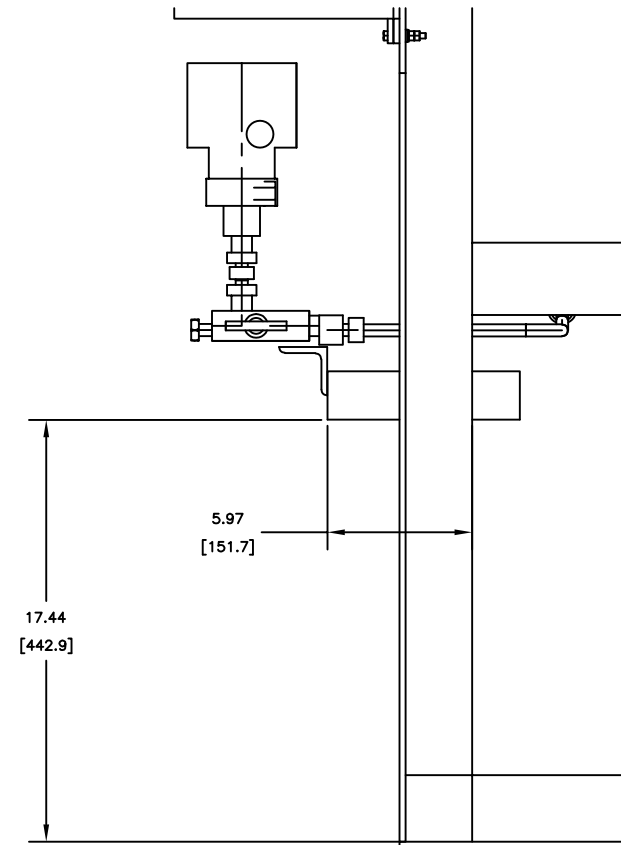

Code1	<input type="checkbox"/> No Comment/ Approved (Applicable Only for "FOR REVIEW" and "For Approval" Documents) No comment and the document are released for Manufacturing
Code2	<input type="checkbox"/> No Comment/ Approved with Note(s) Vendor/Sub-Contractor shall correct, revise and resubmit the document. The document is released for Manufacturing if changes incorporated.
Code3	<input type="checkbox"/> Commented Vendor/Sub-Contractor shall correct, revise and resubmit the document by the date specified. The document shall be revised under the Status of "R: Revised Issue". All corrected documents shall be resubmitted before starting the Manufacturing Process
Code4	<input type="checkbox"/> Not Accepted (Rejected) Vendor/Sub-Contractor shall re-work/re-design/re-specify the contents of the document according to the comments/reasons for rejection. All corrected documents shall be resubmitted before starting the manufacturing. Vendor Sub-Contractor shall not proceed with subsequent works of Material Supply or Manufacturing until receiving Code1/Code2 or No Code from PURCHASER. Vendor/Sub-Contractor shall resubmit the document with the same revision within 6 working days after receiving comments
No Code	<input type="checkbox"/> No Code (Only for "For Information" Documents and "As Built DWG") Document has been submitted for PURCHASER'S information (FI). Consistency, completeness and correctness of document content is in Vendor/Sub-Contractor's responsibility.

The above checking result by EIED shall in no way relieve Vendor of any liability, obligation and responsibility out of the purchase order and the mutual agreement in writing

DATE :
DEPT :
Signature :

CV	PI	EL	IN	ME	MA
ST	BU	PR	SA	HV	TL

01	08-FEB-2026	IP1	D.SH	F.T	A.M
00	08-DEC-2025	IP1	D.SH	F.T	A.M
REV.	DATE (DD.MM.YY)	Purpose of Issue	Prepared	Checked	Approved
		Gachsaran Polymer Industries Company HDPE Plant			
PO No.: GPIC-PT-MA-PO-000-3029					SCALE: 1:1
DRAWING TITLE: Instruments Hookup Diagram and MTO					
DRAWING NO. VD-GPIC-MA-3029-3029-0051			REV. 01	SHEET NO. 36 of 39	SIZE A3

BILL OF MATERIALS				
PIPE				
ID	QTY	ND	DESCRIPTION	
1	2'-9 5/8"	1/2"	TUBING, ASTM A269, SEAMLESS - 316SS	0.065" THK
FITTINGS				
ID	QTY	ND	DESCRIPTION	
2	2	1/2"	BEND 90 5R, TUBING, ASTM A269, 316SS	
3	1	1/2"	PLUG, HEX HEAD, MPT, ASME B16.11	
VALVES				
ID	QTY	ND	DESCRIPTION	
4	1	1/2"	2-Way-Manifold	
PIPE SUPPORTS				
ID	QTY	ND	DESCRIPTION	
5	1	1/2"	U-clamp	

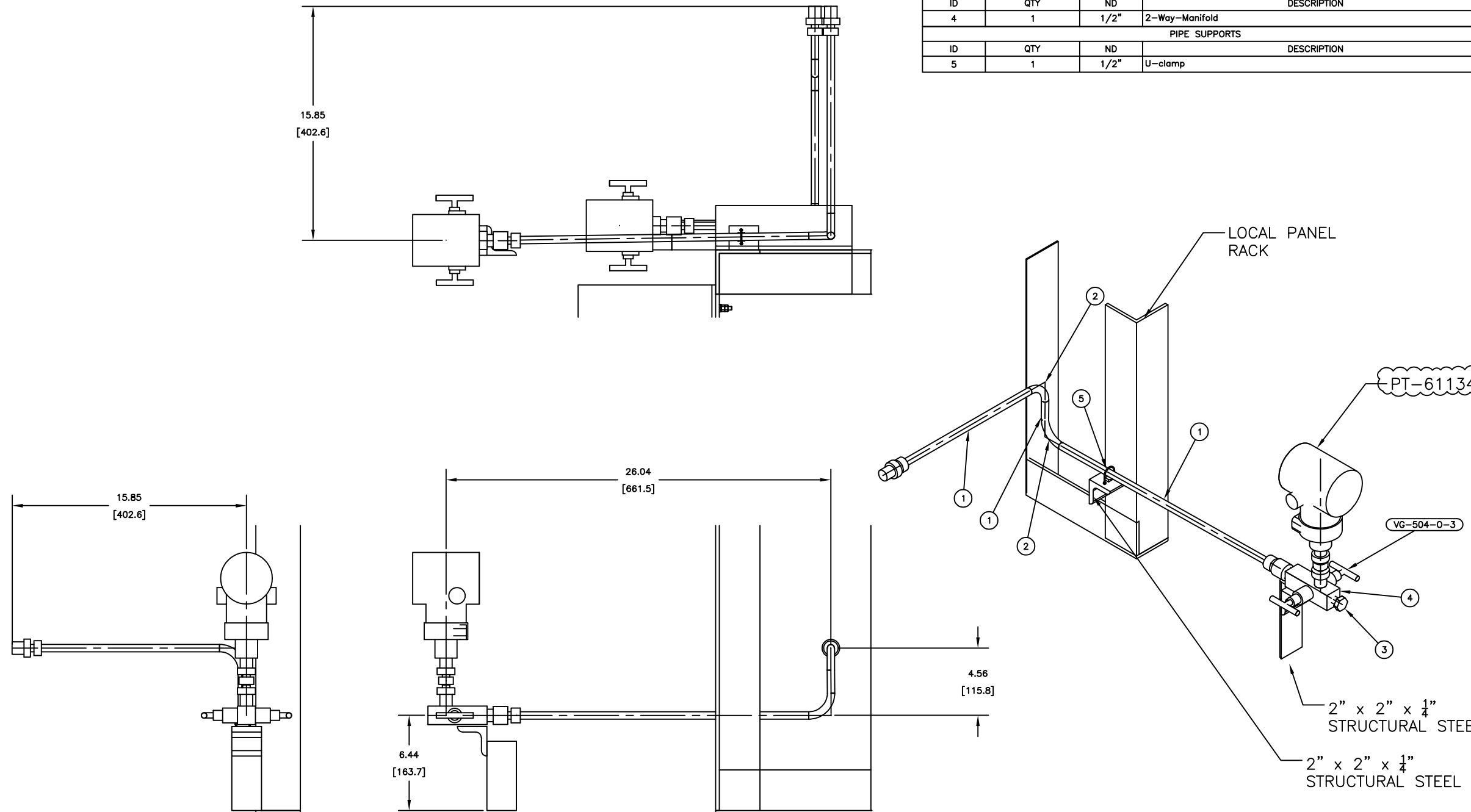

Code1	<input type="checkbox"/> No Comment/ Approved (Applicable Only for "FOR REVIEW" and "For Approval" Documents) No comment and the document are released for Manufacturing				
Code2	<input type="checkbox"/> No Comment/ Approved with Note(s) Vendor/Sub-Contractor shall correct, revise and resubmit the document. The document is released for Manufacturing if changes incorporated.				
Code3	<input type="checkbox"/> Commented Vendor/Sub-Contractor shall correct, revise and resubmit the document by the date specified. The document shall be revised under the Status of "To Be Revised Issue". All corrected documents shall be resubmitted before starting the Manufacturing Process				
Code4	<input type="checkbox"/> Not Accepted (Rejected) Vendor/Sub-Contractor shall re-work/re-design/re-specify the contents of the document according to the comments/reasons for rejection. All corrected documents shall be resubmitted before starting the manufacturing. Vendor Sub-Contractor shall not proceed with subsequent works of Material Supply or Manufacturing until receiving Code1/Code2 or No Code from PURCHASER. Vendor/Sub-Contractor shall resubmit the document with the same revision within 6 working days after receiving comments				
No Code	<input type="checkbox"/> No Code (Only for "For Information" Documents and "As Built DWGs") Document has been submitted for PURCHASER'S Information (FI). Consistency, completeness and correctness of document content is in Vendor/Sub-Contractor's responsibility. The above checking result by EIED shall in no way relieve Vendor of any liability, obligation and responsibility out of the purchase order and the mutual agreement in writing				
DATE :					
DEPT:					
Signature :					
CV	PI	EL	IN	ME	MA
ST	BU	PR	SA	HV	TL

01	08-FEB-2026	IFI	D.SH	F.T	A.M
00	08-DEC-2025	IFI	D.SH	F.T	A.M
REV.	DATE (DD.MM.YY)	Purpose of Issue	Prepared	Checked	Approved
		Gachsaran Polymer Industries Company HDPE Plant			
PO No.: GPIC-PT-MA-PO-000-3029					SCALE: 1:1
DRAWING TITLE: Instruments Hookup Diagram and MTO					
DRAWING NO. VD-GPIC-MA-3029-0051			REV.	SHEET NO.	SIZE
			01	37 of 39	A3

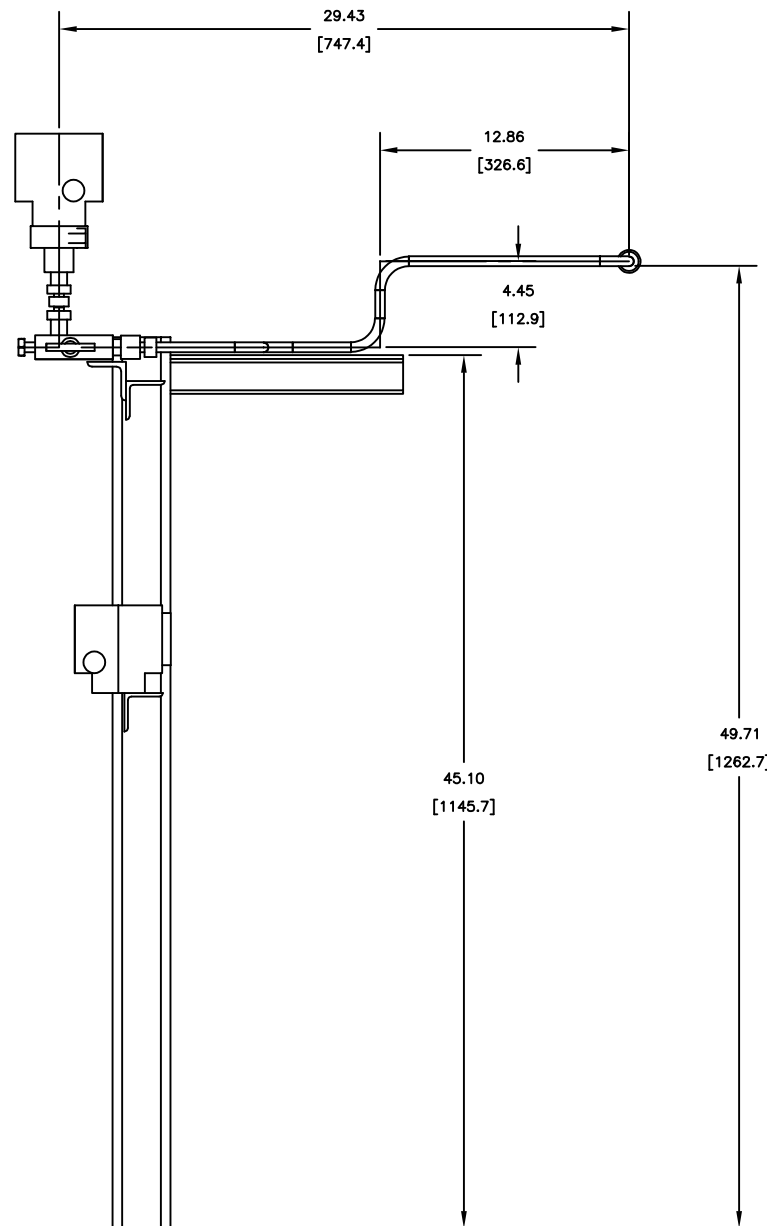
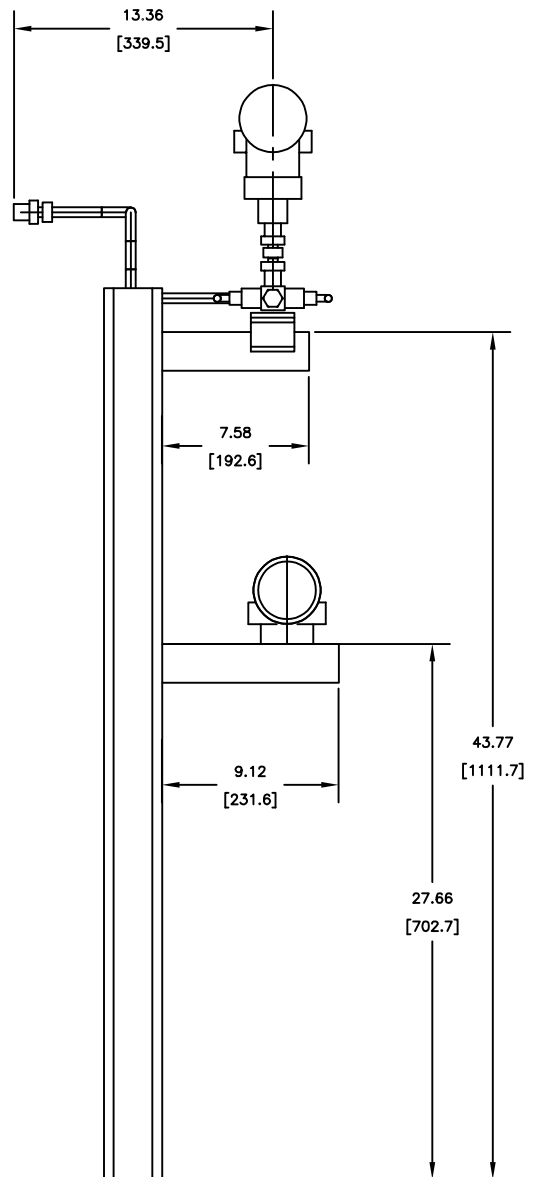
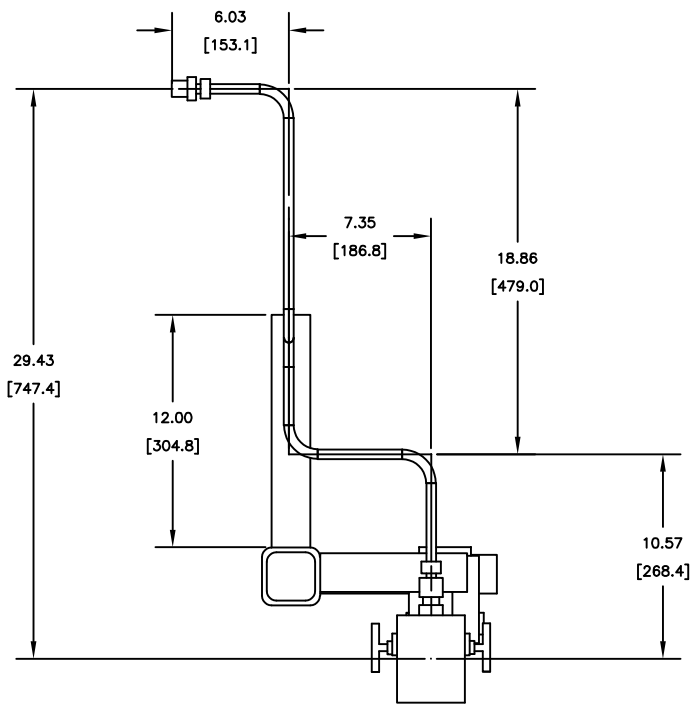

BILL OF MATERIALS				
PIPE				
ID	QTY	ND	DESCRIPTION	
1	2'-2"	1/2"	TUBING, ASTM A269, SEAMLESS -- 316SS	0.065" THK
FITTINGS				
ID	QTY	ND	DESCRIPTION	
2	5	1/2"	BEND 90 5R, TUBING, ASTM A269, 316SS	
3	1	1/2"	PLUG, HEX HEAD, MPT, ASME B16.11	
4	1	3/4"x1/2"	Male Connector 3/4" NPT(M) x 1/2" T	
VALVES				
ID	QTY	ND	DESCRIPTION	
5	1	1/2"	2-Way-Manifold	

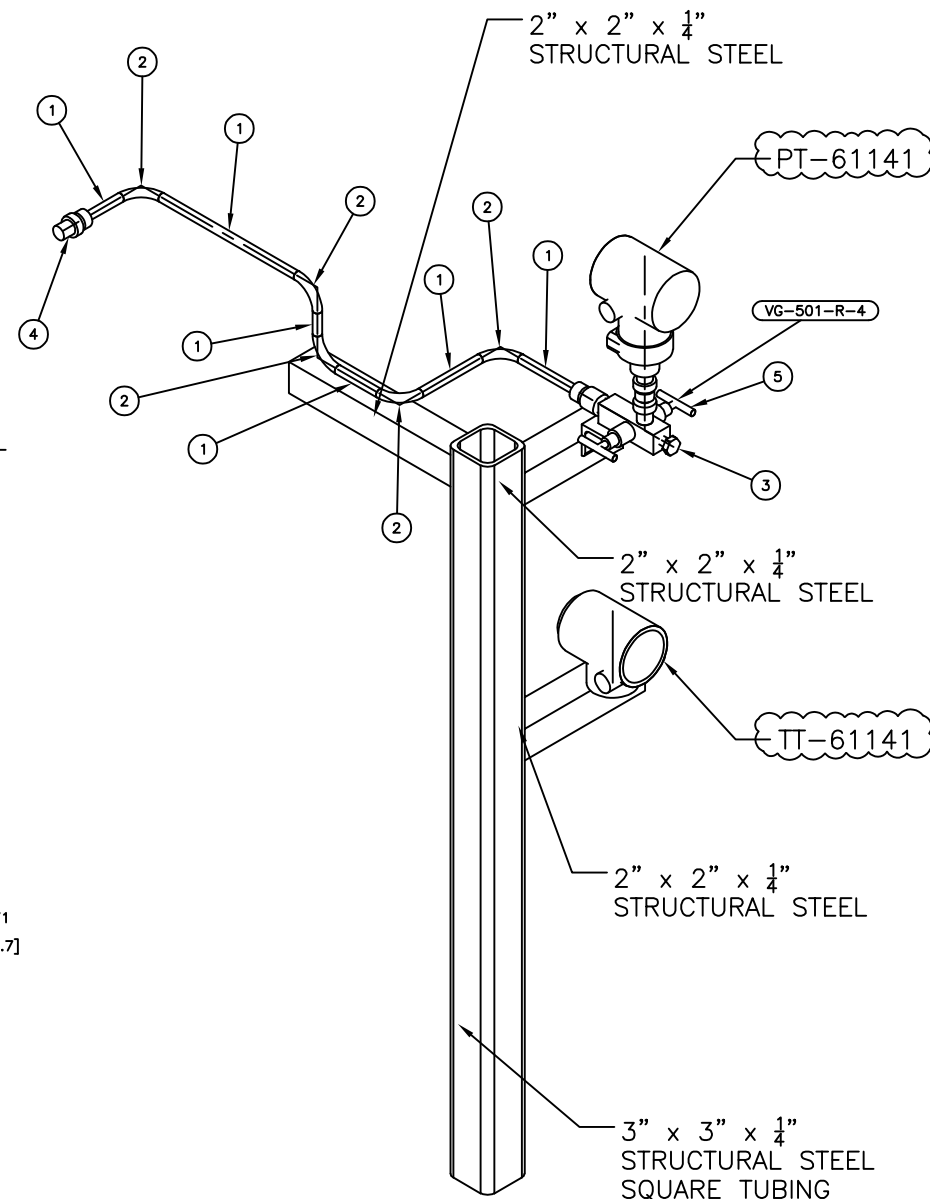

Code1	<input type="checkbox"/> No Comment/ Approved (Applicable Only for "FOR REVIEW" and "For Approval" Documents) No comment and the document are released for Manufacturing				
Code2	<input type="checkbox"/> No Comment/ Approved with Note(s) Vendor/Sub-Contractor shall correct, revise and resubmit the document. The document is released for Manufacturing if changes incorporated.				
Code3	<input type="checkbox"/> Commented Vendor/Sub-Contractor shall correct, revise and resubmit the document by the date specified. The document shall be revised under the Status of "Re-Released Issue". All corrected documents shall be resubmitted before starting the Manufacturing Process				
Code4	<input type="checkbox"/> Not Accepted (Rejected) Vendor/Sub-Contractor shall re-work/re-design/re-specify the contents of the document according to the comments/reasons for rejection. All corrected documents shall be resubmitted before starting the manufacturing. Vendor/Sub-Contractor shall not proceed with subsequent works of Material Supply or Manufacturing until receiving Code1/Code2 or No Code from PURCHASER. Vendor/Sub-Contractor shall resubmit the document with the same revision within 6 working days after receiving comments				
No Code	<input type="checkbox"/> No Code (Only for "For information" Documents and "As Built DWG's") Document has been submitted for PURCHASER'S information (F). Consistency, completeness and correctness of document content is in Vendor/Sub-Contractor's responsibility. The above checking result by EIED shall in no way relieve Vendor of any liability, obligation and responsibility out of the purchase order and the mutual agreement in writing				
DATE : DEPT : Signature :					
CV	PI	EL	IN	ME	MA
ST	BU	PR	SA	HV	TL

01	08-FEB-2026	IFI	D.SH	F.T	A.M
00	08-DEC-2025	IFI	D.SH	F.T	A.M
REV.	DATE (DD-MMM-YY)	Purpose of Issue	Prepared	Checked	Approved
		Gachsaran Polymer Industries Company HDPE Plant			
PO No.: GPIC-PT-MA-PO-000-3029 DRAWING TITLE: Instruments Hookup Diagram and MTO SCALE: 1:1					
DRAWING NO. VD-GPIC-MA-3029-3029-0051			REV. SHEET NO. SIZE 01 38 of 39 A3		

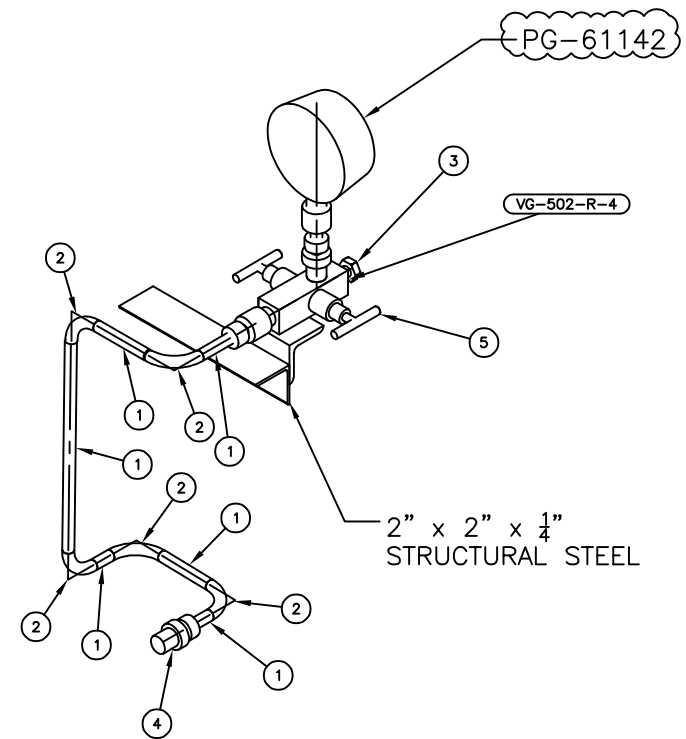
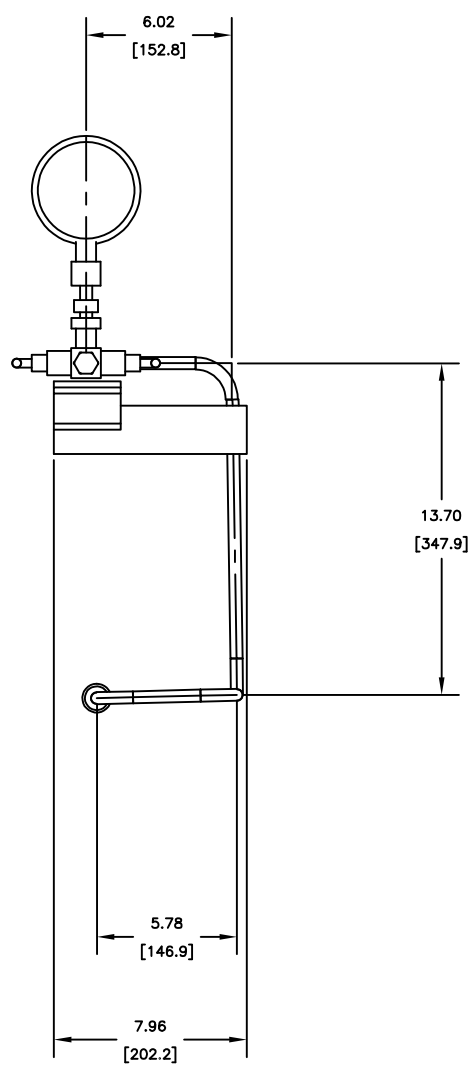
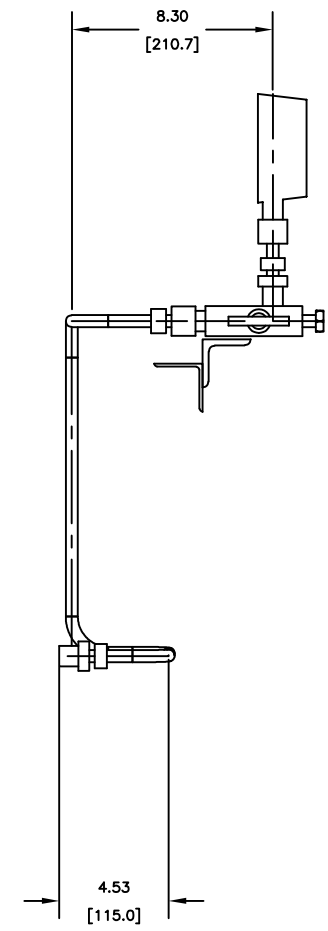
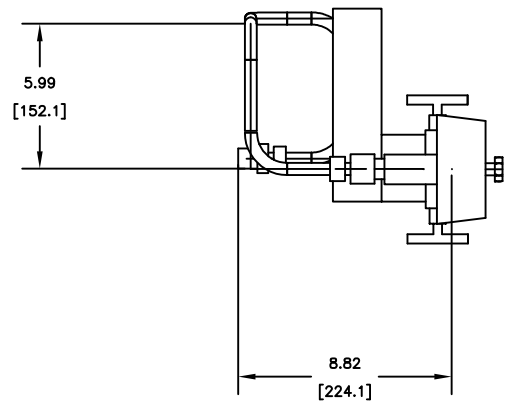

BILL OF MATERIALS			
PIPE			
ID	QTY	ND	DESCRIPTION
1	1'-8 15/16"	1/2"	TUBING, ASTM A269, SEAMLESS - 316SS
FITTINGS			
ID	QTY	ND	DESCRIPTION
2	5	1/2"	BEND 90 5R, TUBING, ASTM A269, 316SS
3	1	1/2"	PLUG, HEX HEAD, MPT, ASME B16.11
4	1	3/4"x1/2"	Male Connector 3/4" NPT(M) x 1/2" T
VALVES			
ID	QTY	ND	DESCRIPTION
5	1	1/2"	2-Way-Manifold

0.065" THK

Code1	<input type="checkbox"/> No Comment/ Approved (Applicable Only for "FOR REVIEW" and "For Approval" Documents) No comment and the document are released for Manufacturing
Code2	<input type="checkbox"/> No Comment/ Approved with Note(s) Vendor/Sub-Contractor shall correct, revise and resubmit the document. The document is released for Manufacturing if changes incorporated.
Code3	<input type="checkbox"/> Commented Vendor/Sub-Contractor shall correct, revise and resubmit the document by the date specified. The document shall be revised under the Status of "R: Revised Issue". All corrected documents shall be resubmitted before starting the Manufacturing Process
Code4	<input type="checkbox"/> Not Accepted (Rejected) Vendor/Sub-Contractor shall re-work/re-design/re-specify the contents of the document according to the comments/reasons for rejection. All corrected documents shall be resubmitted before starting the manufacturing. Vendor Sub-Contractor shall not proceed with subsequent works of Material Supply or Manufacturing until receiving Code1/Code2 or No Code from PURCHASER. Vendor/Sub-Contractor shall resubmit the document with the same revision within 6 working days after receiving comments
No Code	<input type="checkbox"/> No Code (Only for "For Information" Documents and "As Built DWG") Document has been submitted for PURCHASER'S Information (R). Consistency, completeness and correctness of document content is in Vendor/Sub-Contractor's responsibility.
The above checking result by EIED shall in no way relieve Vendor of any liability, obligation and responsibility out of the purchase order and the mutual agreement in writing	
DATE : DEPT : Signature :	
CV	PI
ST	BU
	PR
	SA
	IN
	ME
	HV
	MA
	TL

01	06-FEB-2020	IF1	D.SH	F.T	A.M
00	09-DEC-2005	IF1	D.SH	F.T	A.M
REV.	DATE (DD.MM.YY)	Purpose of Issue	Prepared	Checked	Approved
		Gachsaran Polymer Industries Company HDPE Plant			
PO No.: GPIC-PT-MA-PO-000-3029					
DRAWING TITLE: Instruments Hookup Diagram and MTO					
DRAWING NO. VD-GPIC-MA-3029-3029-0051			REV.	SHEET NO.	SIZE
			01	39 of 39	A3