



	Gachsaran Polymer Industries Company HDPE Plant		
	Instruments Hookup Diagram and MTO	 	
PO No.: GPIC-PT-MA-PO-000-3029	Document Number: VD-GPIC-MA-3029-3029-0051	Rev. 00	Page 1 of 17

Instruments Hookup Diagram and MTO

Code1	<input type="checkbox"/> No Comment/ Approved (Applicable Only for "FOR REVIEW" and "For Approval" Documents) No comment and the document are released for Manufacturing.
Code2	<input type="checkbox"/> No Comment/ Approved with Note(s) Vendor/Sub-Contractor shall correct, revise and resubmit the document. The document is released for Manufacturing if changes incorporated.
Code3	<input checked="" type="checkbox"/> Commented Vendor/Sub-Contractor shall correct, revise and resubmit the document by the date specified. The document shall be revised under the Status of "R: Revised Issue". All corrected documents shall be resubmitted before starting the Manufacturing Process.
Code 4	<input type="checkbox"/> Not Accepted (Rejected) Vendor/Sub-Contractor shall re-work / re-design / re-specify the contents of the document according to the comments / reasons for rejection. All corrected documents shall be resubmitted before starting the manufacturing. Vendor/Sub-Contractor shall not proceed with subsequent works of Material Supply or Manufacturing until receiving Code1/Code2 or No Code from PURCHASER. Vendor/Sub-Contractor shall resubmit the document with the same revision within 6 working days after receiving comments.
No code	<input type="checkbox"/> No Code (Applicable Only for "For Information" Documents and "As Built DWGs") Document has been submitted for PURCHASER's Information (FI). Consistency, completeness and correctness of document content is in Vendor/Sub-Contractor's responsibility.

Above checking results by EIED shall in no way relieve Vendor of any liability, obligation and responsibility out of the purchase order and the mutual agreement in writing.

 Energy Industries Engineering & Design co.	Date: Dec.27, 2025 Dept.: MA Signature: F.Hamooni
--	--

00	9-Dec-25	IFI	DSH	F.T	A.M
Rev.	DATE	PURPOSE OF ISSUE	PREPARED	CHECKED	APPROVED



**Gachsaran Polymer Industries Company
HDPE Plant
Instruments Hookup Diagram and
MTO**



PO No.: GPIC-PT-MA-PO-000-3029

Document Number: VD-GPIC-MA-3029-3029-0051

Rev.
00

Page 3 of 17

IN-01. All items of hookup material in the next sheets shall be mentioned in the below table.

- Vendor Reply: Noted



MTO for Tube Fittings

Long Description (Family)	Compatible Standard	Size	Line Number Tag
PLUG, HEX HEAD, MPT, ASME B16.11	ASME B16.11	1/2"	PG-61131
PLUG, HEX HEAD, 1/2" NPT (M), ASME B16.11	ASME B16.11	1/2"	PT-61111
PLUG, HEX HEAD, 1/2" NPT (M), ASME B16.11	ASME B16.11	1/2"	PT-61111
PLUG, HEX HEAD, 1/2" NPT (M), ASME B16.11	ASME B16.11	1/2"	PT-61113
PLUG, HEX HEAD, 1/2" NPT (M), ASME B16.11	ASME B16.11	1/2"	PT-61113
PLUG, HEX HEAD, 1/2" NPT (M), ASME B16.11	ASME B16.11	1/2"	PT-61121
PLUG, HEX HEAD, 1/2" NPT (M), ASME B16.11	ASME B16.11	1/2"	PT-61121
PLUG, HEX HEAD, 1/2" NPT (M), ASME B16.11	ASME B16.11	1/2"	PT-61123
PLUG, HEX HEAD, 1/2" NPT (M), ASME B16.11	ASME B16.11	1/2"	PT-61123
PLUG, HEX HEAD, 1/2" NPT (M), ASME B16.11	ASME B16.11	1/2"	PT-61131
PLUG, HEX HEAD, 1/2" NPT (M), ASME B16.11	ASME B16.11	1/2"	PT-61131
PLUG, HEX HEAD, MPT, ASME B16.11	ASME B16.11	1/2"	PT-61132
PLUG, HEX HEAD, MPT, ASME B16.11	ASME B16.11	1/2"	PT-61132
PLUG, HEX HEAD, 1/2" NPT (M), ASME B16.11	ASME B16.11	1/2"	PT-61133
PLUG, HEX HEAD, 1/2" NPT (M), ASME B16.11	ASME B16.11	1/2"	PT-61134
PLUG, HEX HEAD, 1/2" NPT (M), ASME B16.11	ASME B16.11	1/2"	PT-61141
PLUG, HEX HEAD, 1/2" NPT (M), ASME B16.11	ASME B16.11	1/2"	PT-61142

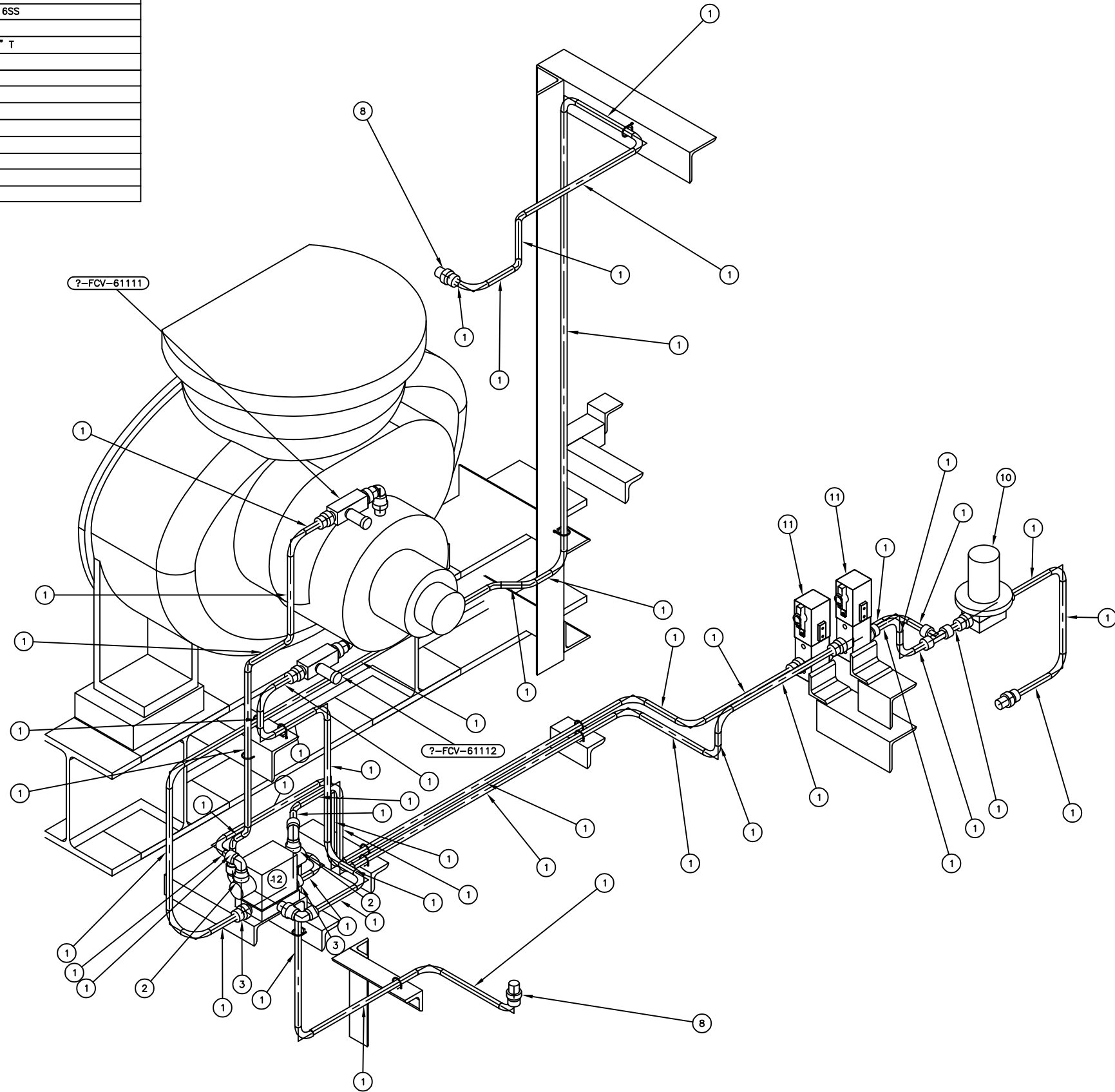
BILL OF MATERIALS		
PIPE		
ID	QTY	LONG DESCRIPTION (FAMILY)
1	31'-3 7/16"	TUBING, ASTM A269, SEAMLESS -- 316SS
FITTINGS		
ID	QTY	LONG DESCRIPTION (FAMILY)
2	2	STUB 1/4NPT(M) x 1/2"Tube
3	2	MaleConnector 1/2 NPT(M) x 1/2"Tube
4	1	BEND 90 5R, TUBING, ASTM A269, 316SS
5	33	BEND 90 5R, TUBING, ASTM A269, 316SS
6	9	BEND 45 5R, TUBING, ASTM A269, 316SS
7	2	Union ELB, Tubing, 1/4" to 1"
8	2	Male Connector 3/4" NPT(M) x 1/2" T
9	1	Union_TEE_1/4" to 1"
VALVES		
ID	QTY	LONG DESCRIPTION (FAMILY)
10	1	Regulator-1/4"
11	2	Solenoid, 1/4" to 1/2"
12	1	Direction Vale. 1/2"
PIPE SUPPORTS		
ID	QTY	LONG DESCRIPTION (FAMILY)
13	11	U-clamp



Code1	<input type="checkbox"/> No Comment/ Approved (Applicable Only for "FOR REVIEW" and "For Approval" Documents) No comment and the document are released for Manufacturing				
Code2	<input type="checkbox"/> No Comment/ Approved with Note(s) Vendor/Sub-Contractor shall correct, revise and resubmit the document. The document is released for Manufacturing if changes incorporated.				
Code3	<input type="checkbox"/> Commented Vendor/Sub-Contractor shall correct, revise and resubmit the document by the date specified. The document shall be re-released under the Status of "Re- Revised Issue". All corrected documents shall be resubmitted before starting the Manufacturing Process				
Code4	<input type="checkbox"/> Not Accepted (Rejected) Vendor/Sub-Contractor shall re-work/re-design/re-specify the contents of the document according to the comments/reasons for rejection. All corrected documents shall be resubmitted before starting the manufacturing. Vendor/Sub-Contractor shall not proceed with subsequent works of Material Supply or Manufacturing until receiving Code1/Code2 or No Code from PURCHASER. Vendor/Sub-Contractor shall resubmit the document with the same revision within 6 working days after receiving comments				
No Code	<input type="checkbox"/> No Code (Only for "For Information" Documents and "As Built DWGs") Document has been submitted for PURCHASER'S information (FI). Consistency, completeness and correctness of document content is in Vendor/Sub-Contractor's responsibility. The above checking result by EIED shall in no way relieve Vendor of any liability, obligation and responsibility out of the purchase order and the mutual agreement in writing				
					
DATE :					
DEPT :					
Signature :					
CV	PI	EL	IN	ME	MA
ST	BU	PR	SA	HV	TL

00	09-DEC-2025	IFI	D.SH	F.T	A.M
REV.	DATE (DD/MMA/YY)	Purpose of Issue	Prepared	Checked	Approved
		Gachsan Polymer Industries Company HDPE Plant			
PO No.: GPIC-PT-MA-PO-000-3029					SCALE: 1:1
DRAWING TITLE: Instruments Hookup Diagram and MTO					
DRAWING NO. VD-GPIC-MA-3029-3029-0051				REV. SHEET NO. SIZE 00 4 of 17 A3	

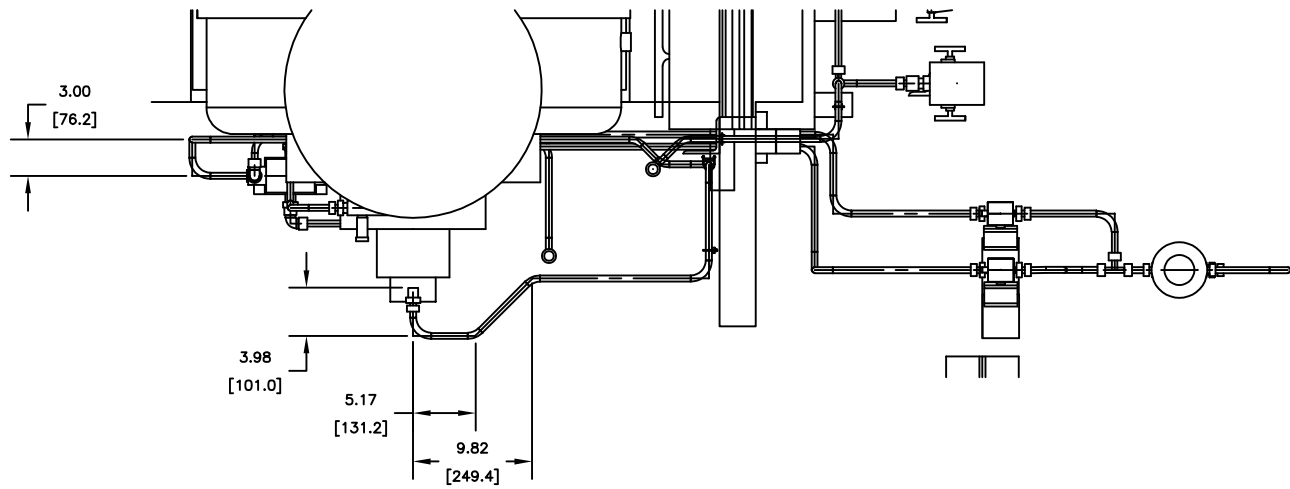

IN-02. Table of MTO is missing in this sheet.
 - Vendor Reply: MTO for this sheet has been specified in previous sheet

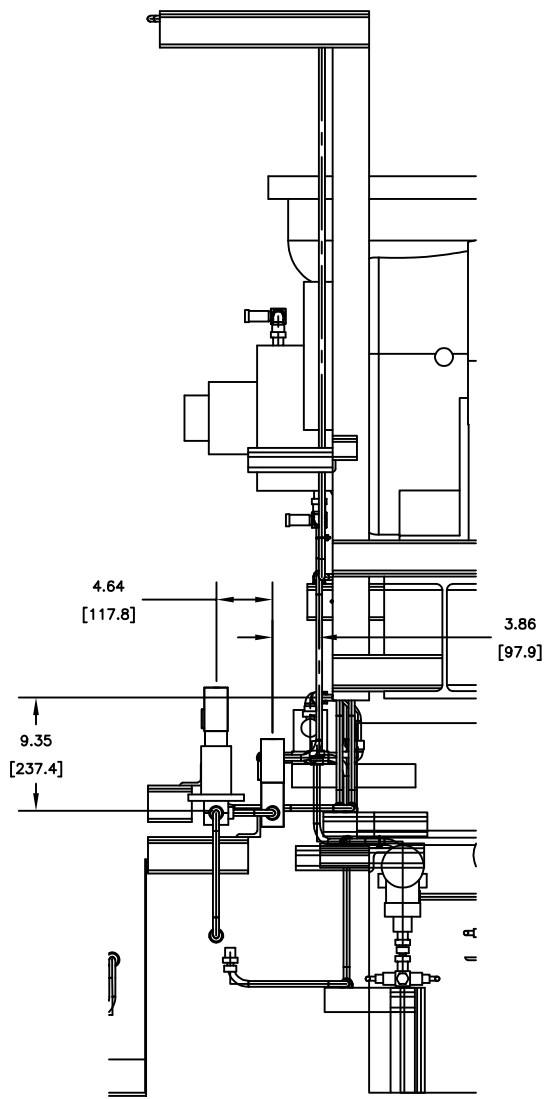
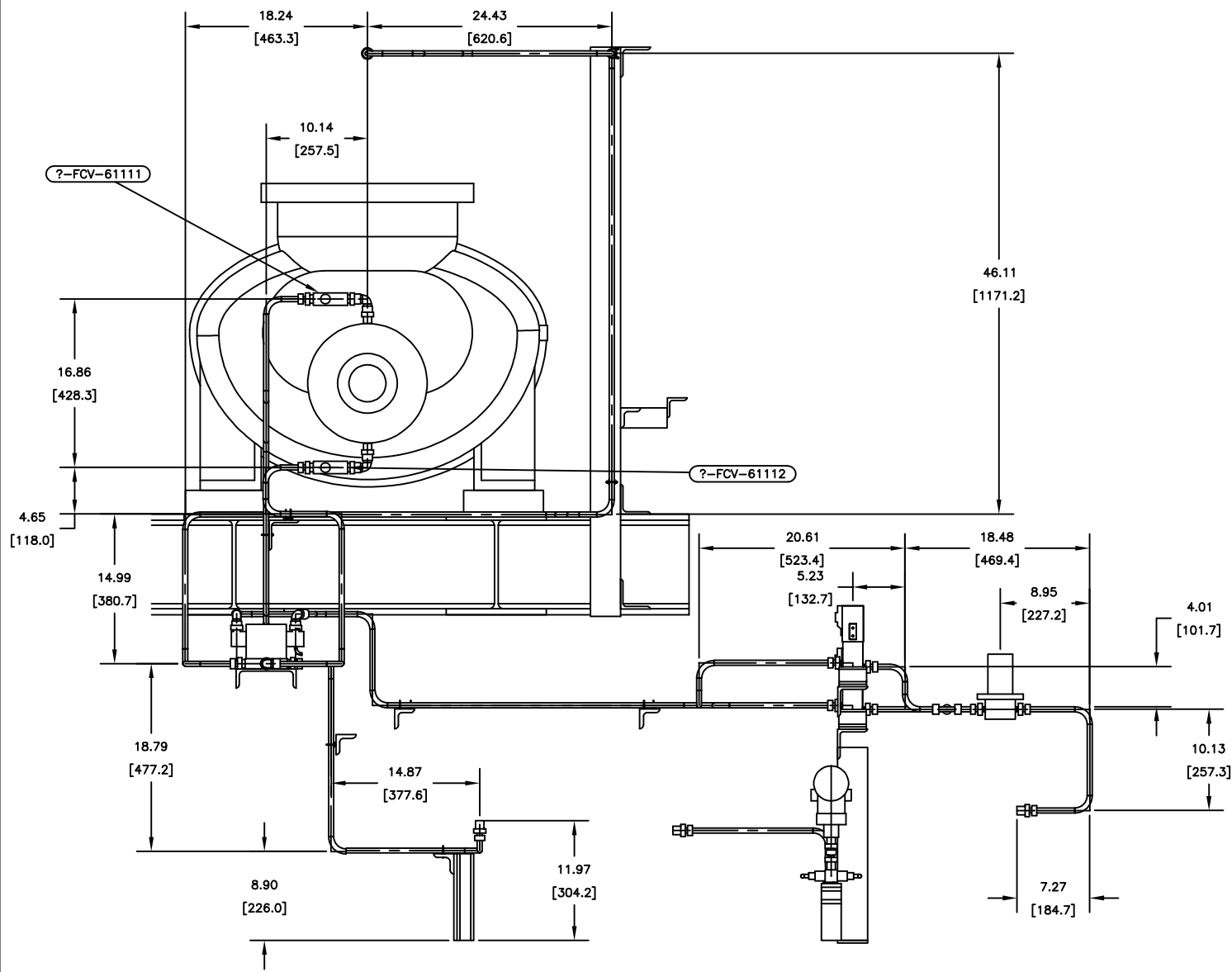

Code1	<input type="checkbox"/> No Comment/ Approved (Applicable Only for "FOR REVIEW" and "For Approval" Documents) No comment and the document are released for Manufacturing
Code2	<input type="checkbox"/> No Comment/ Approved with Note(s) Vendor/Sub-Contractor shall correct, revise and resubmit the document. The document is released for Manufacturing if changes incorporated.
Code3	<input type="checkbox"/> Commented Vendor/Sub-Contractor shall correct, revise and resubmit the document by the date specified. The document shall be revised under the Status of "To Be Revised Issue". All corrected documents shall be resubmitted before starting the Manufacturing Process
Code4	<input type="checkbox"/> Not Accepted (Rejected) Vendor/Sub-Contractor shall re-work/re-design/re-specify the contents of the document according to the comments/reasons for rejection. All corrected documents shall be resubmitted before starting the manufacturing. Vendor/Sub-Contractor shall not proceed with subsequent works of Material Supply or Manufacturing until receiving Code1/Code2 or No Code from PURCHASER. Vendor/Sub-Contractor shall resubmit the document with the same revision within 6 working days after receiving comments
No Code	<input type="checkbox"/> No Code (Only for "For Information" Documents and "As Built DWGs") Document has been submitted for PURCHASER'S Information (FI). Consistency, completeness and correctness of document content is in Vendor/Sub-Contractor's responsibility.

The above checking result by EIED shall in no way relieve Vendor of any liability, obligation and responsibility out of the purchase order and the mutual agreement in writing

EIED

DATE :
DEPT :
Signature :

CV	PI	EL	IN	ME	MA
ST	BU	PR	SA	HV	TL

00	09-DEC-2025	IFI	D.SH	F.T	A.M
REV.	DATE (DD.MM.YY)	Purpose of Issue	Prepared	Checked	Approved
		Gachsaran Polymer Industries Company HDPE Plant			
PO No.: GPIC-PT-MA-PO-000-3029					SCALE: 1:1
DRAWING TITLE: Instruments Hookup Diagram and MTO					
DRAWING NO. VD-GPIC-MA-3029-3029-0051			REV. 00	SHEET NO. 5 of 17	SIZE A3

BILL OF MATERIALS		
PIPE		
ID	QTY	LONG DESCRIPTION (FAMILY)
1	26'-5 3/16"	TUBING, ASTM A269, SEAMLESS -- 316SS
FITTINGS		
ID	QTY	LONG DESCRIPTION (FAMILY)
2	1	Male Connector, 316SS, NPT(M) x Tube
3	2	MaleStub 1/4" NPT(M) x 1/2" Tube
4	2	Male Connector 1/2" NPT(M) x 1/2" T
5	32	BEND 90 5R, TUBING, ASTM A269, 316SS
6	9	BEND 45 5R, TUBING, ASTM A269, 316SS
7	2	Union ELB, Tubing, 1/4" to 1"
8	2	Male Connector 3/4" NPT(M) x 1/2" T
9	1	Union_TEE_1/4" to 1"
VALVES		
ID	QTY	LONG DESCRIPTION (FAMILY)
10	1	Regulator-1/4" NPT(F)
11	2	Solenoid, 1/4" NPT(F)
12	1	Direction Vale. 1/2"
PIPE SUPPORTS		
ID	QTY	LONG DESCRIPTION (FAMILY)
13	10	U-clamp

IN-03. Tag No. is missing in this sheet.
 - Vendor Reply: Noted

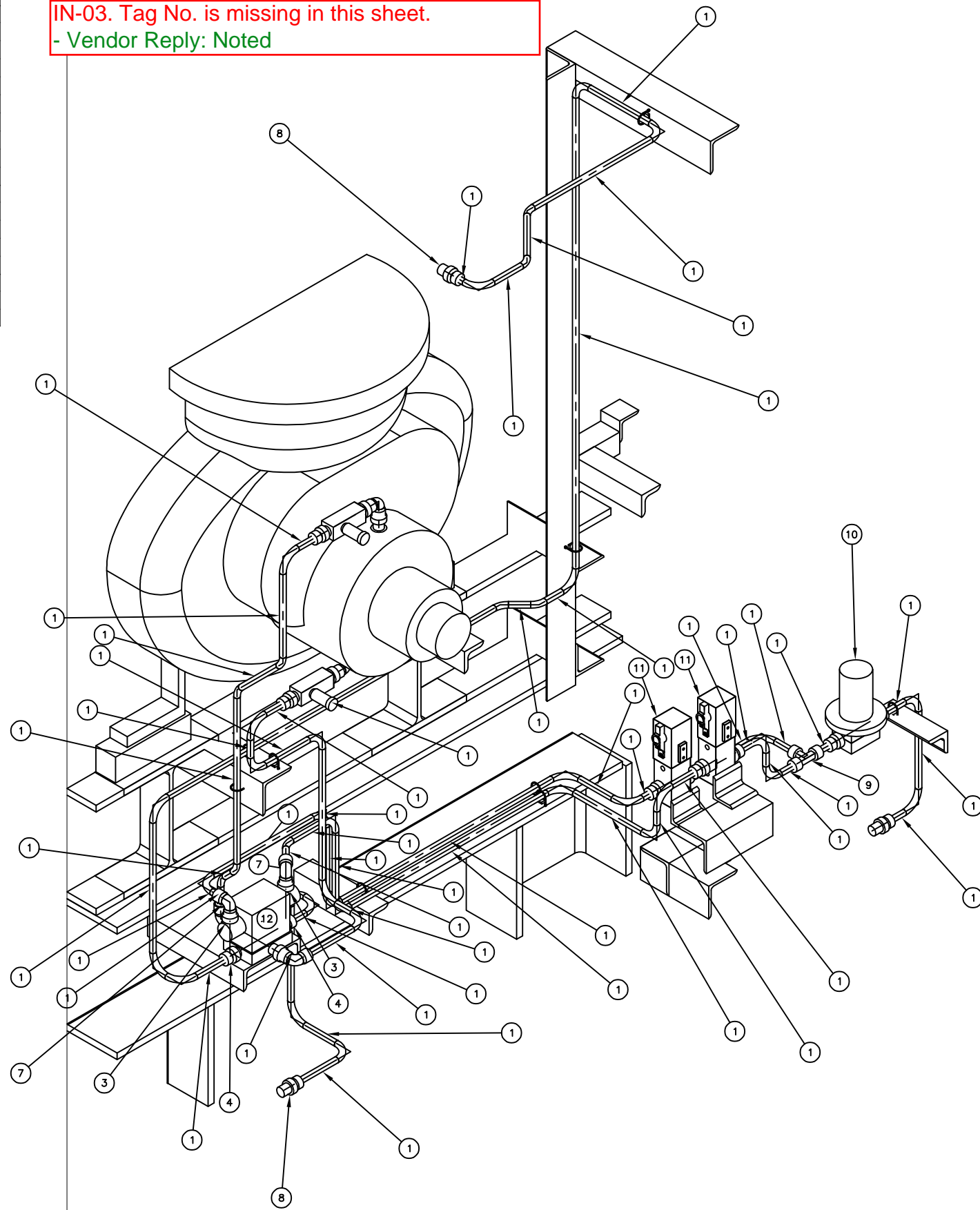

Code1	<input type="checkbox"/> No Comment/ Approved (Applicable Only for "FOR REVIEW" and "For Approval" Documents) No comment and the document are released for Manufacturing
Code2	<input type="checkbox"/> No Comment/ Approved with Note(s) Vendor/Sub-Contractor shall correct, revise and resubmit the document. The document is released for Manufacturing if changes incorporated.
Code3	<input type="checkbox"/> Commented Vendor/Sub-Contractor shall correct, revise and resubmit the document by the date specified. The document shall be revised under the Status of "R: Revised Issue". All corrected documents shall be resubmitted before starting the Manufacturing Process
Code4	<input type="checkbox"/> Not Accepted (Rejected) Vendor/Sub-Contractor shall re-work/re-design/re-specify the contents of the document according to the comments/reasons for rejection. All corrected documents shall be resubmitted before starting the manufacturing. Vendor/Sub-Contractor shall not proceed with subsequent works of Material Supply or Manufacturing until receiving Code/Code2 or No Code from PURCHASER. Vendor/Sub-Contractor shall resubmit the document with the same revision within 6 working days after receiving comments
No Code	<input type="checkbox"/> No Code (Only for "For Information" Documents and "As Built DWGs") Document has been submitted for PURCHASER'S Information (I). Consistency, completeness and correctness of document content is in Vendor/Sub-Contractor's responsibility.

The above checking result by EIED shall in no way relieve Vendor of any liability, obligation and responsibility out of the purchase order and the mutual agreement in writing

DATE :	
DEPT:	
Signature :	

CV	PI	EL	IN	ME	MA
ST	BU	PR	SA	HV	TL

00	09-DEC-2025	IFI	D.SH	F.T	A.M
REV.	DATE (DD.MM.YY)	Purpose of Issue	Prepared	Checked	Approved
		Gachsaran Polymer Industries Company HDPE Plant			
PO No.: GPIC-PT-MA-PO-000-3029					SCALE: 1:1
DRAWING TITLE: Instruments Hookup Diagram and MTO					
DRAWING NO. VD-GPIC-MA-3029-3029-0051			REV.	SHEET NO.	SIZE
			00	6 of 17	A3

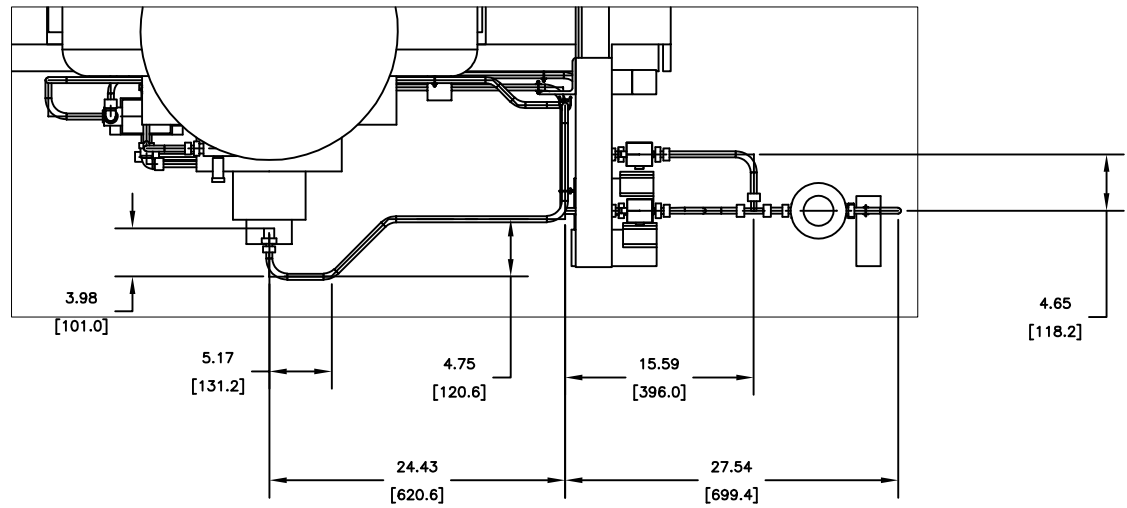

IN-04. Table of MTO and tag no. are missing in this sheet.
 - Vendor Reply: MTO for this sheet has been specified in previous sheet

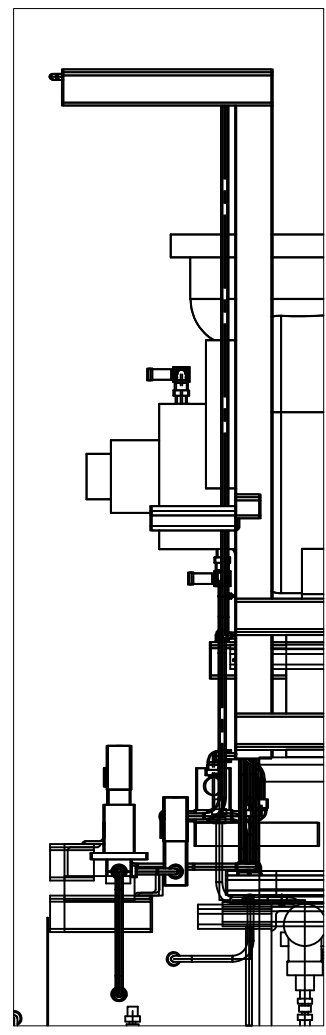
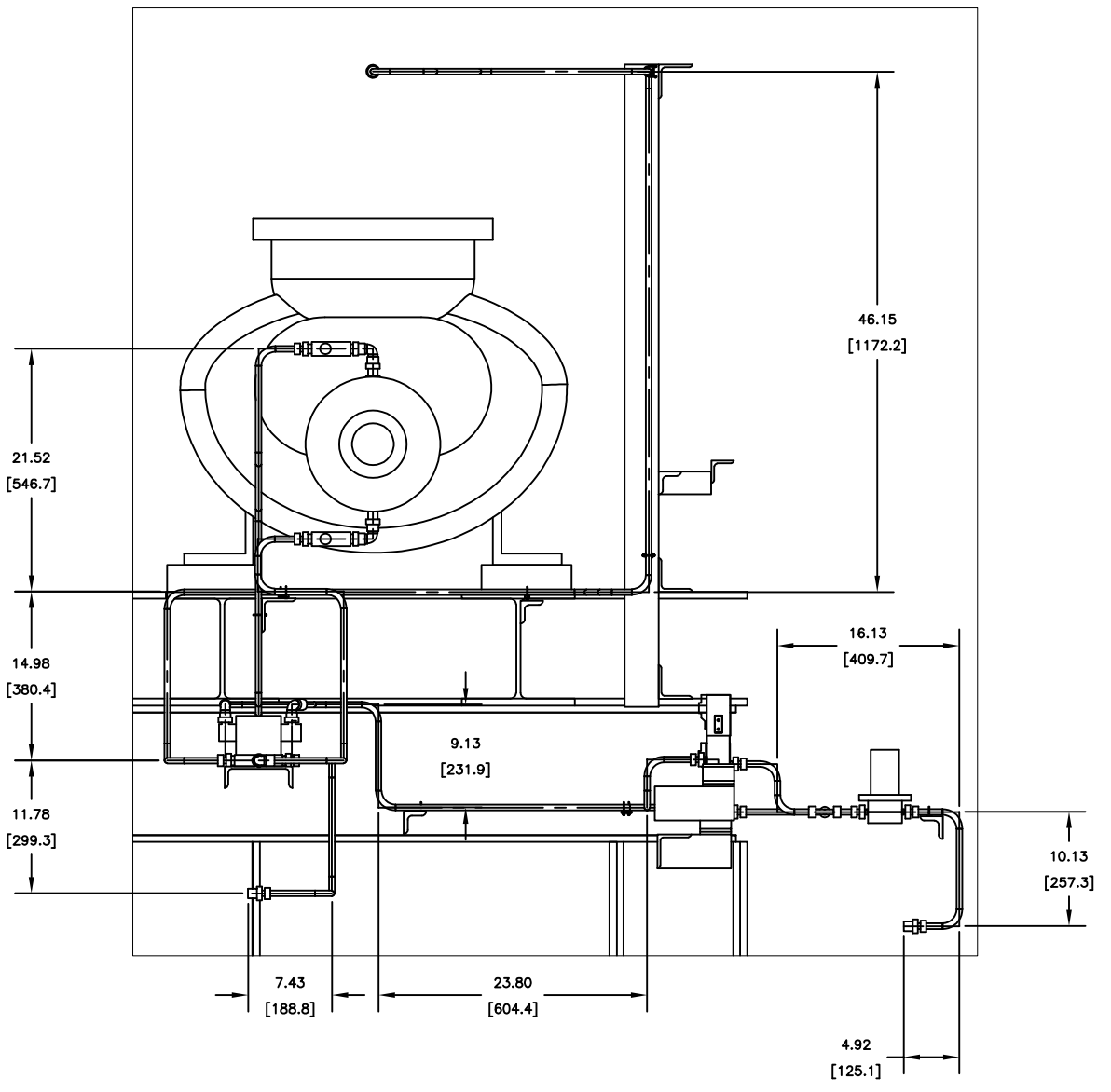

Code1	<input type="checkbox"/> No Comment/ Approved (Applicable Only for "FOR REVIEW" and "For Approval" Documents) No comment and the document are released for Manufacturing				
Code2	<input type="checkbox"/> No Comment/ Approved with Note(s) Vendor/Sub-Contractor shall correct, revise and resubmit the document. The document is released for Manufacturing if changes incorporated.				
Code3	<input type="checkbox"/> Commented Vendor/Sub-Contractor shall correct, revise and resubmit the document by the date specified. The document shall be revised under the Status of "R: Revised Issue". All corrected documents shall be resubmitted before starting the Manufacturing Process				
Code4	<input type="checkbox"/> Not Accepted (Rejected) Vendor/Sub-Contractor shall re-work/re-design/re-specify the contents of the document according to the comments/reasons for rejection. All corrected documents shall be resubmitted before starting the manufacturing. Vendor Sub-Contractor shall not proceed with subsequent works of Material Supply or Manufacturing until receiving Code1/Code2 or No Code from PURCHASER. Vendor/Sub-Contractor shall resubmit the document with the same revision within 6 working days after receiving comments				
No Code	<input type="checkbox"/> No Code (Only for "For Information" Documents and "As Built DWGs") Document has been submitted for PURCHASER'S information (I). Consistency, completeness and correctness of document content is in Vendor/Sub-Contractor's responsibility.				
The above checking result by EIED shall in no way relieve Vendor of any liability, obligation and responsibility out of the purchase order and the mutual agreement in writing					
DATE : DEPT: Signature :					
CV	PI	EL	IN	ME	MA
ST	BU	PR	SA	HV	TL

00	09-DEC-2025	IFI	D.SH	F.T	A.M
REV.	DATE (DD.MM.YY)	Purpose of Issue	Prepared	Checked	Approved
		Gacharsan Polymer Industries Company HDPE Plant			
PO No.: GPIC-PT-MA-PO-000-3029					SCALE: 1:1
DRAWING TITLE: Instruments Hookup Diagram and MTO					
DRAWING NO. VD-GPIC-MA-3029-3029-0051				REV.	SHEET NO. SIZE
				00	7 of 17 A3

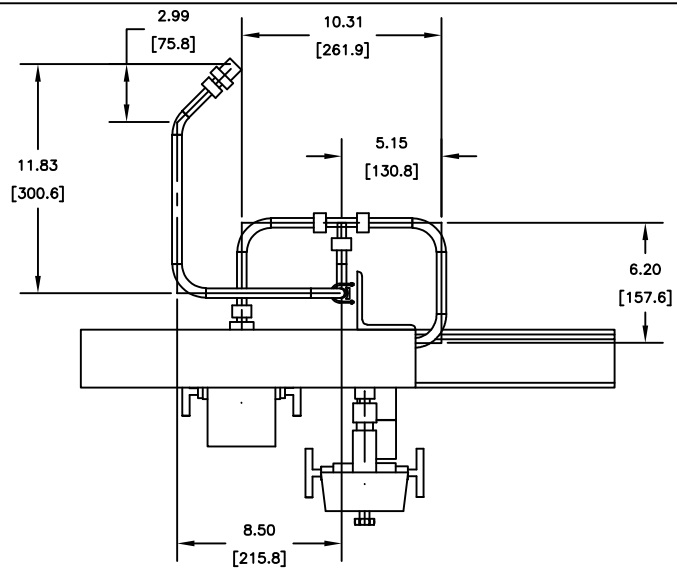

BILL OF MATERIALS				
PIPE				
ID	QTY	ND	DESCRIPTION	
1	5'-0 7/8"	1/2"	TUBING, ASTM A269, SEAMLESS - 316SS	
FITTINGS				
ID	QTY	ND	DESCRIPTION	
2	1	1/2"	BEND 45 5R, TUBING, ASTM A269, 316SS	
3	7	1/2"	BEND 90 5R, TUBING, ASTM A269, 316SS	
4	2	1/2"	PLUG, HEX HEAD, MPT, ASME B16.11	
5	1	3/4"x1/2"	Male Connector 3/4" NPT(M) x 1/2" T	
6	1	1/2"	Union_TEE_1/4" to 1"	
VALVES				
ID	QTY	ND	DESCRIPTION	
7	2	1/2"	2-Way-Manifold	
PIPE SUPPORTS				
ID	QTY	ND	DESCRIPTION	
8	2	1/2"	U-clamp	

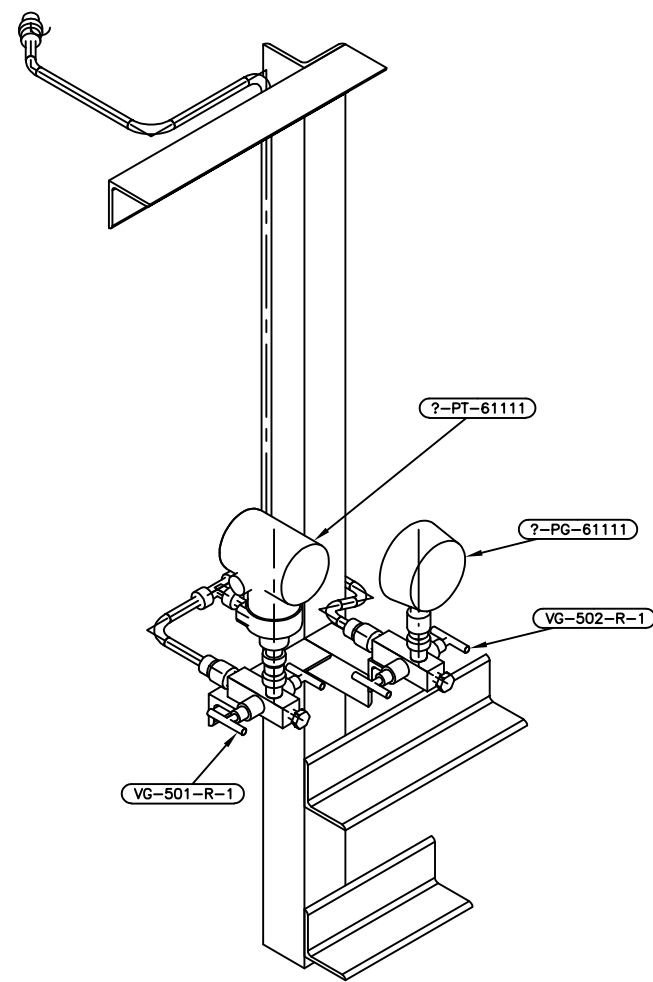
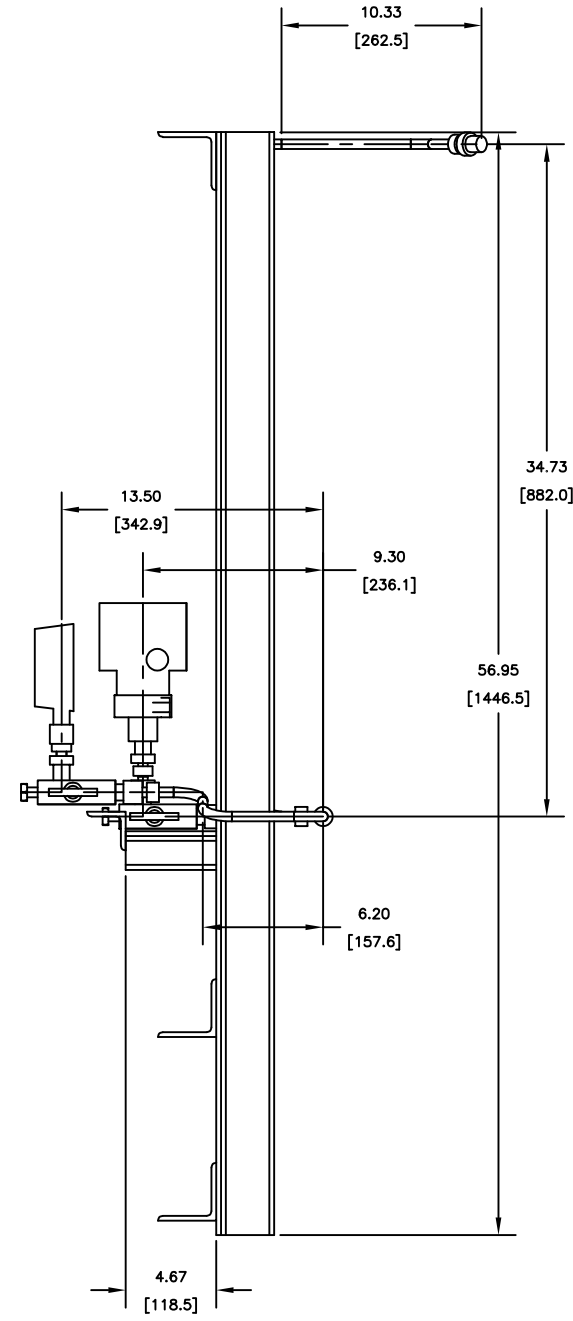
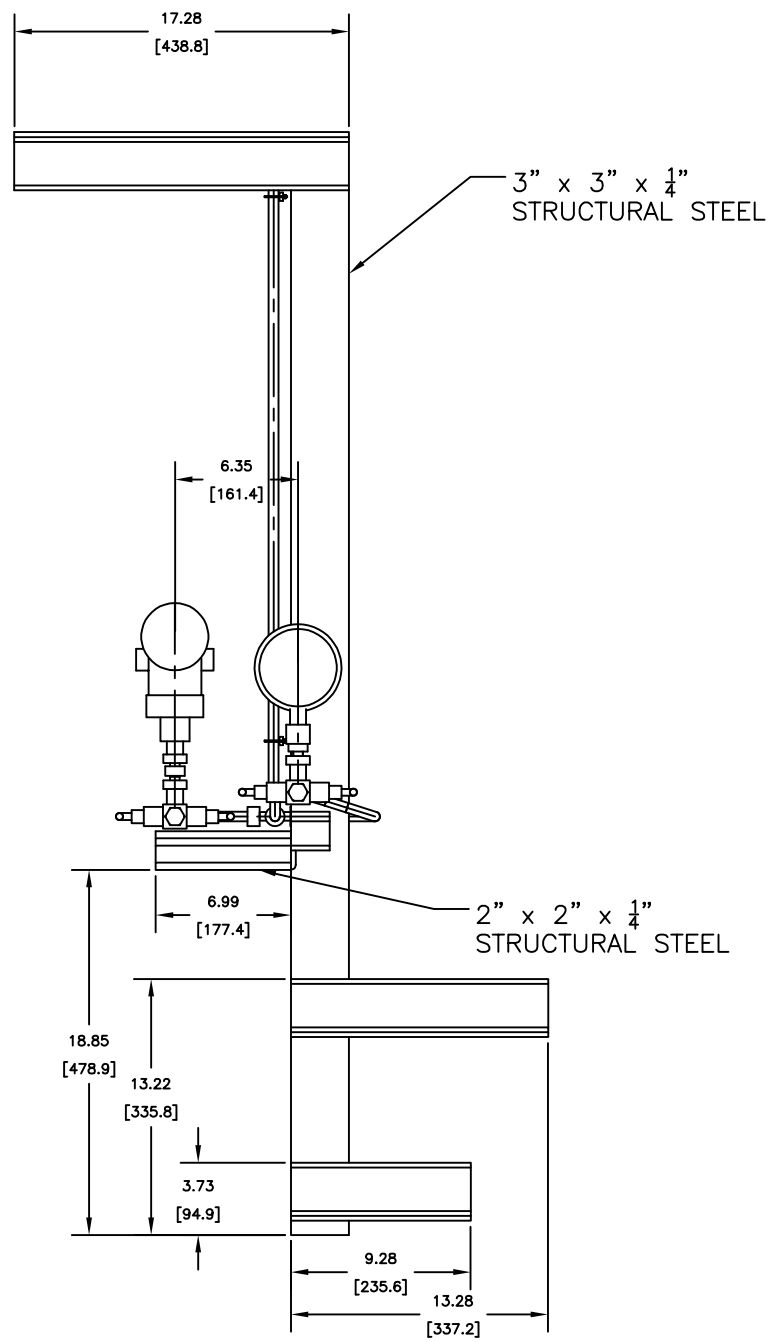

Code1	<input type="checkbox"/> No Comment/ Approved (Applicable Only for "FOR REVIEW" and "For Approval" Documents) No comment and the document are released for Manufacturing
Code2	<input type="checkbox"/> No Comment/ Approved with Note(s) Vendor/Sub-Contractor shall correct, revise and resubmit the document. The document is released for Manufacturing if changes incorporated.
Code3	<input type="checkbox"/> Commented Vendor/Sub-Contractor shall correct, revise and resubmit the document by the date specified. The document shall be revised under the Status of "To Be Revised Issue". All corrected documents shall be resubmitted before starting the Manufacturing Process
Code4	<input type="checkbox"/> Not Accepted (Rejected) Vendor/Sub-Contractor shall re-work/re-design/re-specify the contents of the document according to the comments/reasons for rejection. All corrected documents shall be resubmitted before starting the manufacturing. Vendor Sub-Contractor shall not proceed with subsequent works of Material Supply or Manufacturing until receiving Code/Code2 or No Code from PURCHASER. Vendor/Sub-Contractor shall resubmit the document with the same revision within 6 working days after receiving comments
No Code	<input type="checkbox"/> No Code (Only for "For Information" Documents and "As Built DWGs") Document has been submitted for PURCHASER's Information (If) Consistency, completeness and correctness of document content is in Vendor/Sub-Contractor's responsibility.

The above checking result by EIED shall in no way relieve Vendor of any liability, obligation and responsibility out of the purchase order and the mutual agreement in writing

DATE :
DEPT :
Signature :

CV	PI	EL	IN	ME	MA
ST	BU	PR	SA	HV	TL

00	09-DEC-2025	IFI	D.SH	F.T	A.M
REV.	DATE (DD.MM.YY)	Purpose of Issue	Prepared	Checked	Approved
Gachsaran Polymer Industries Company HDPE Plant					
PO No.: GPIC-PT-MA-PO-000-3029					SCALE: 1:1
DRAWING TITLE: Instruments Hookup Diagram and MTO					
DRAWING NO. VD-GPIC-MA-3029-3029-0051			REV.	SHEET NO.	SIZE
			00	8 of 17	A3

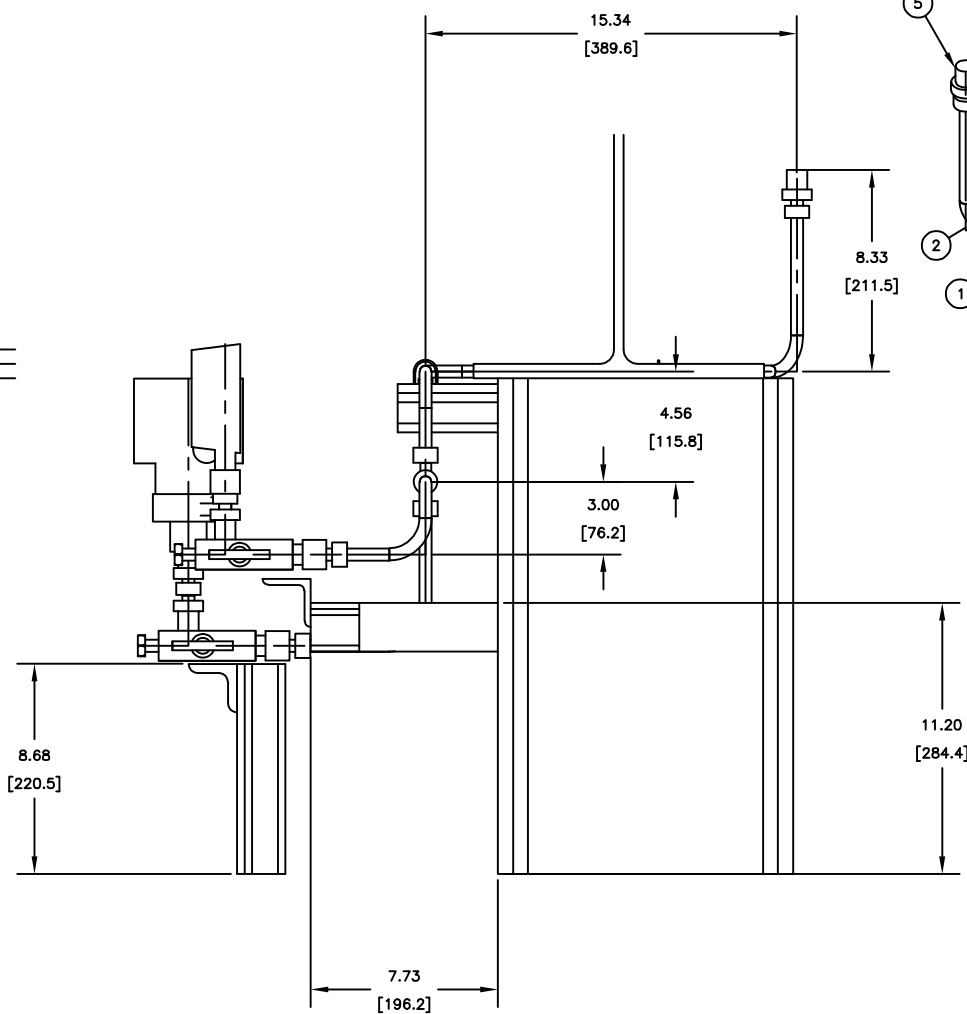
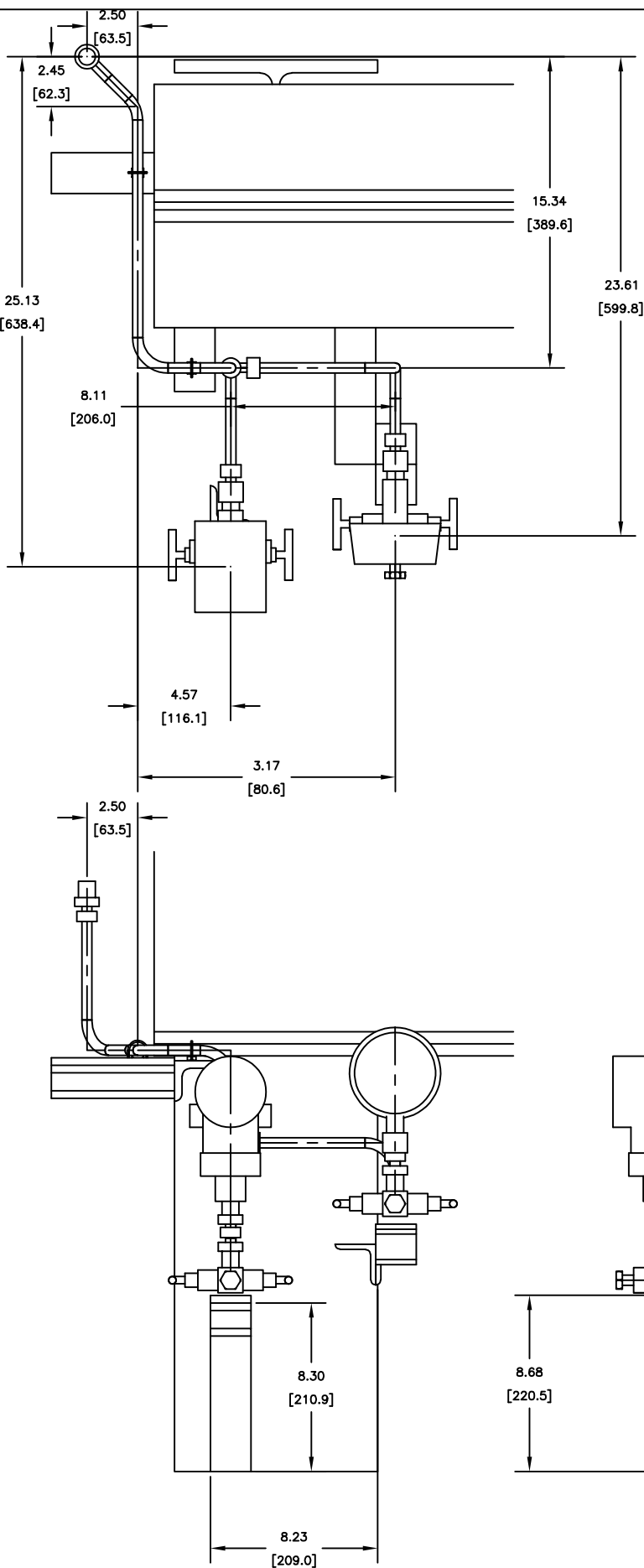

BILL OF MATERIALS			
PIPE			
ID	QTY	ND	DESCRIPTION
1	3'-0	13/16"	TUBING, ASTM A269, SEAMLESS -- 316SS
FITTINGS			
ID	QTY	ND	DESCRIPTION
2	6	1/2"	BEND 90 5R, TUBING, ASTM A269, 316SS
3	1	1/2"	BEND 45 5R, TUBING, ASTM A269, 316SS
4	2	1/2"	PLUG, HEX HEAD, MPT, ASME B16.11
5	1	3/4"x1/2"	Male Connector 3/4" NPT(M) x 1/2" T
6	1	1/2"	Union_TEE_1/4" to 1"
VALVES			
ID	QTY	ND	DESCRIPTION
7	2	1/2"	2-Way-Manifold
PIPE SUPPORTS			
ID	QTY	ND	DESCRIPTION
8	2	1/2"	U-clamp

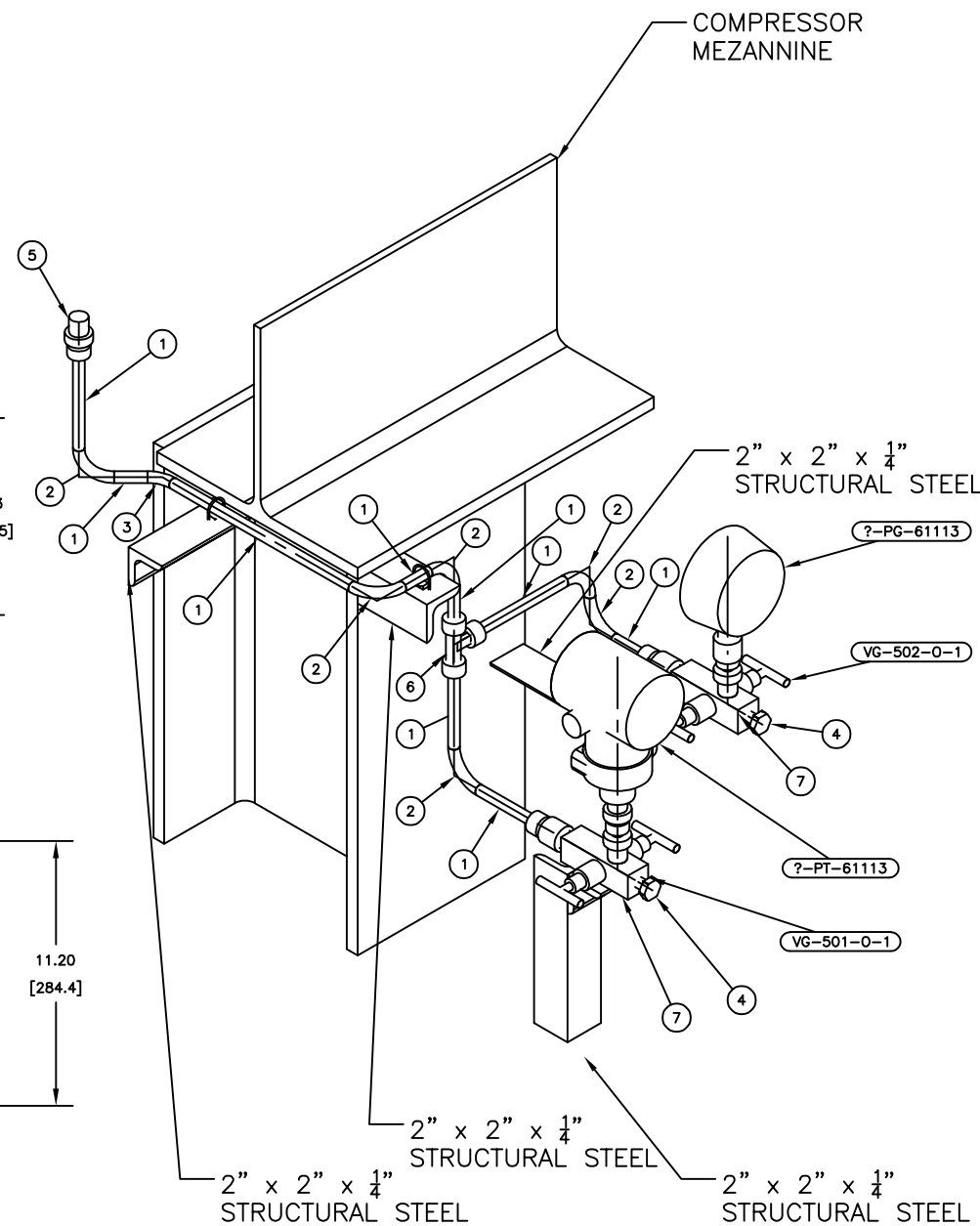

Code1	<input type="checkbox"/> No Comment/ Approved (Applicable Only for "FOR REVIEW" and "For Approval" Documents) No comment and the document are released for Manufacturing.
Code2	<input type="checkbox"/> No Comment/ Approved with Note(s) Vendor/Sub-Contractor shall correct, revise and resubmit the document. The document is released for Manufacturing if changes incorporated.
Code3	<input type="checkbox"/> Commented Vendor/Sub-Contractor shall correct, revise and resubmit the document by the date specified. The document shall be revised under the status of "Revised Issue". All corrected documents shall be resubmitted before starting the Manufacturing Process.
Code4	<input type="checkbox"/> Not Accepted (Rejected) Vendor/Sub-Contractor shall re-work/re-design/re-specify the contents of the document according to the comments/reasons for rejection. All corrected documents shall be resubmitted before starting the manufacturing. Vendor/Sub-Contractor shall not proceed with subsequent works of Material Supply or Manufacturing until receiving Code1/Code2 or No Code from PURCHASER. Vendor/Sub-Contractor shall resubmit the document with the same revision within 6 working days after receiving comments.
No Code	<input type="checkbox"/> No Code (Only for "For Information" Documents and "As Built DWGs") Document has been submitted for PURCHASER'S information (FI). Consistency, completeness and correctness of document content is in Vendor/Sub-Contractor's responsibility.

The above checking result by EIED shall in no way relieve Vendor of any liability, obligation and responsibility out of the purchase order and the mutual agreement in writing.

EIED

DATE: _____
DEPT: _____
Signature: _____

CV	PI	EL	IN	ME	MA
ST	BU	PR	SA	HV	TL

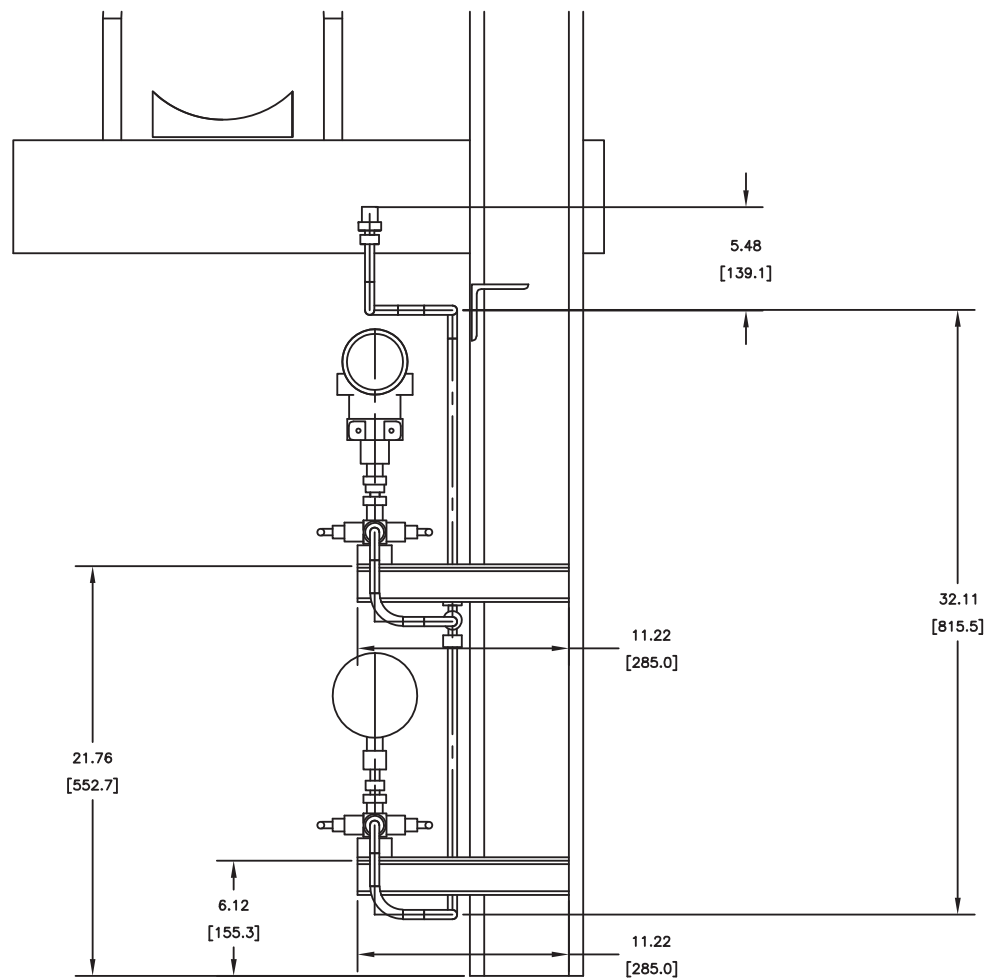
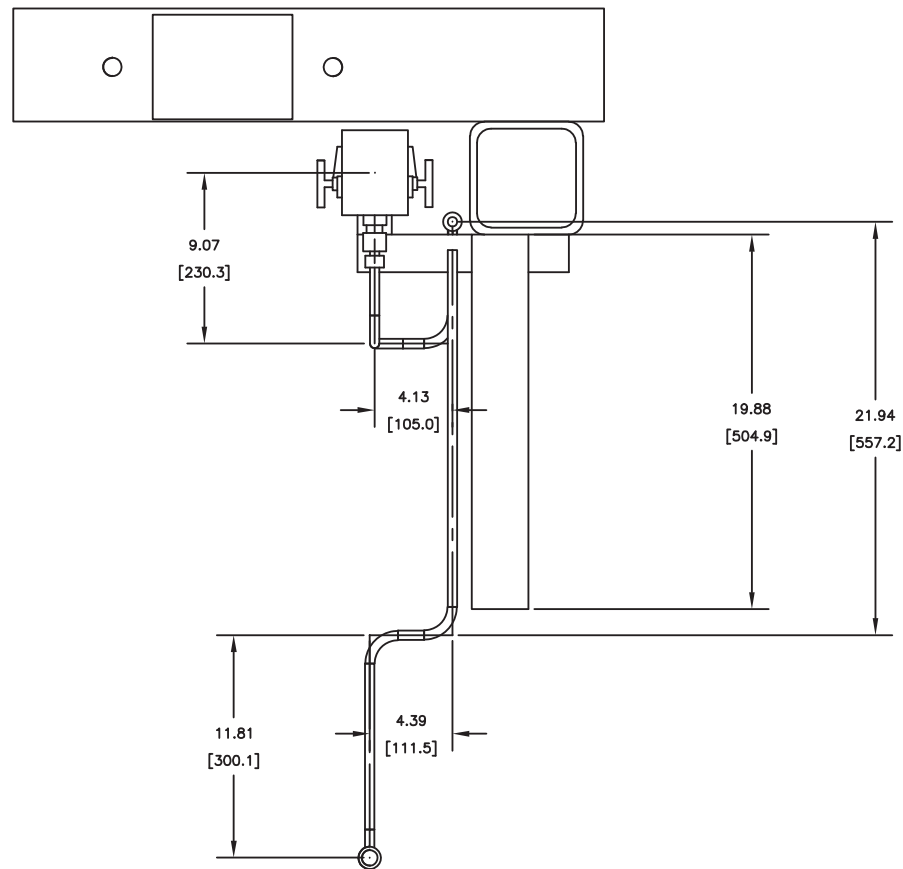

00	09-DEC-2025	IFI	D.SH	F.T	A.M
REV.	DATE (DDMMYY)	Purpose of Issue	Prepared	Checked	Approved
		Gachsan Polymer Industries Company HDPE Plant			
PO No.: GPIC-PT-MA-PO-000-3029					SCALE: 1:1
DRAWING TITLE: Instruments Hookup Diagram and MTO					
DRAWING NO. VD-GPIC-MA-3029-3029-0051			REV. 00	SHEET NO. 9 of 17	SIZE A3

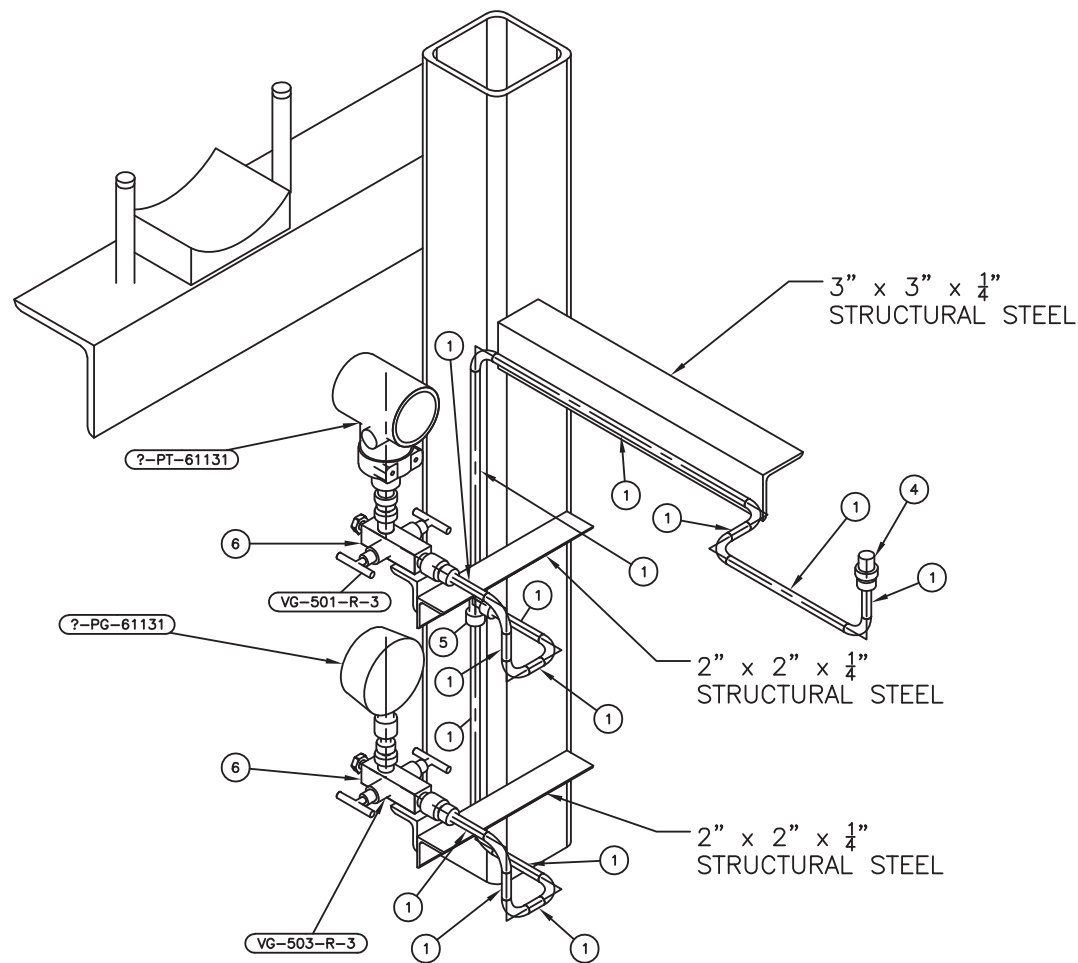

BILL OF MATERIALS			
PIPE			
ID	QTY	ND	DESCRIPTION
1	6'-5 5/16"	1/2"	TUBING, ASTM A269, SEAMLESS - 316SS
FITTINGS			
ID	QTY	ND	DESCRIPTION
2	11	1/2"	BEND 90 5R, TUBING, ASTM A269, 316SS
3	2	1/2"	PLUG, HEX HEAD, MPT, ASME B16.11
4	1	3/4"x1/2"	Male Connector 3/4" NPT(M) x 1/2" T
5	1	1/2"	Union_TEE_1/4" to 1"
VALVES			
ID	QTY	ND	DESCRIPTION
6	2	1/2"	2-Way-Manifold
PIPE SUPPORTS			
ID	QTY	ND	DESCRIPTION
7	1	10"	U-clamp



Code1	<input type="checkbox"/> No Comment/ Approved (Applicable Only for "FOR REVIEW" and "For Approval" Documents) No comment and the document are released for Manufacturing				
Code2	<input type="checkbox"/> No Comment/ Approved with Note(s) Vendor/Sub-Contractor shall correct, revise and resubmit the document. The document is released for Manufacturing if changes incorporated.				
Code3	<input type="checkbox"/> Commented Vendor/Sub-Contractor shall correct, revise and resubmit the document by the date specified. The document shall be revised under the Status of "R: Revised Issue". All corrected documents shall be resubmitted before starting the Manufacturing Process				
Code4	<input type="checkbox"/> Not Accepted (Rejected) Vendor/Sub-Contractor shall re-work/re-design/re-specify the contents of the document according to the comments/reasons for rejection. All corrected documents shall be resubmitted before starting the manufacturing. Vendor/Sub-Contractor shall not proceed with subsequent works of Material Supply or Manufacturing until receiving Code1/Code2 or No Code from PURCHASER. Vendor/Sub-Contractor shall resubmit the document with the same revision within 6 working days after receiving comments				
No Code	<input type="checkbox"/> No Code (Only for "For Information" Documents and "As Built DWGs") Document has been submitted for PURCHASER's information (I). Consistency, completeness and correctness of document content is in Vendor/Sub-Contractor's responsibility.				
The above checking result by EIED shall in no way relieve Vendor of any liability, obligation and responsibility out of the purchase order and the mutual agreement in writing					
 DATE : DEPT : Signature :					
CV	PI	EL	IN	ME	MA
ST	BU	FR	SA	HV	TL

00	09-DEC-2025	IFI	D.SH	F.T	A.M
REV.	DATE (DD-MMM-YY)	Purpose of Issue	Prepared	Checked	Approved
  Gacharan Polymer Industries Company HDPE Plant					
PO No.: GPIC-PT-MA-PO-000-3029				SCALE: 1:1	
DRAWING TITLE: Instruments Hookup Diagram and MTO					
DRAWING NO. VD-GPIC-MA-3029-3029-0051			REV. 00	SHEET NO. 10 of 17	SIZE A3

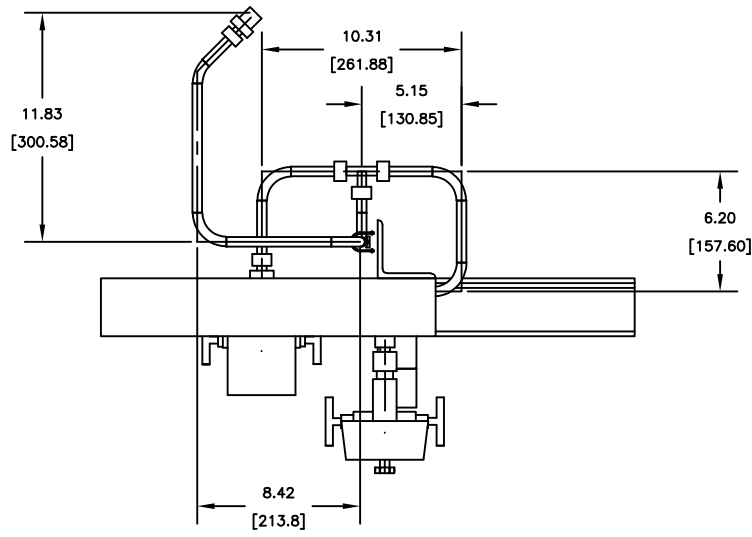

BILL OF MATERIALS			
PIPE			
ID	QTY	ND	DESCRIPTION
1	5'-5 9/16"	1/2"	TUBING, ASTM A269, SEAMLESS - 316SS
FITTINGS			
ID	QTY	ND	DESCRIPTION
2	1	1/2"	BEND 45 5R, TUBING, ASTM A269, 316SS
3	7	1/2"	BEND 90 5R, TUBING, ASTM A269, 316SS
4	2	1/2"	PLUG, HEX HEAD, MPT, ASME B16.11
5	1	3/4"x1/2"	Male Connector 3/4" NPT(M) x 1/2" T
6	1	1/2"	Union_TEE_1/4" to 1"
VALVES			
ID	QTY	ND	DESCRIPTION
7	2	1/2"	2-Way-Manifold
PIPE SUPPORTS			
ID	QTY	ND	DESCRIPTION
8	2	1/2"	U-clamp

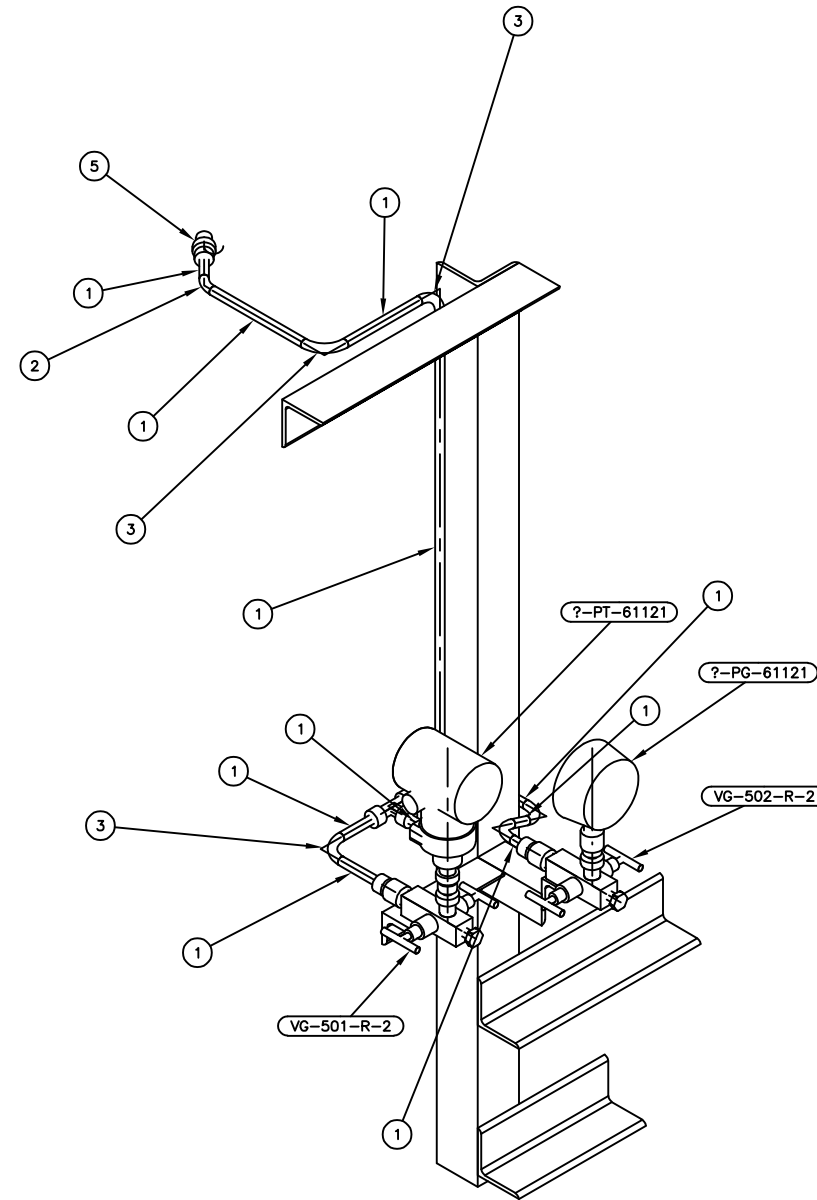
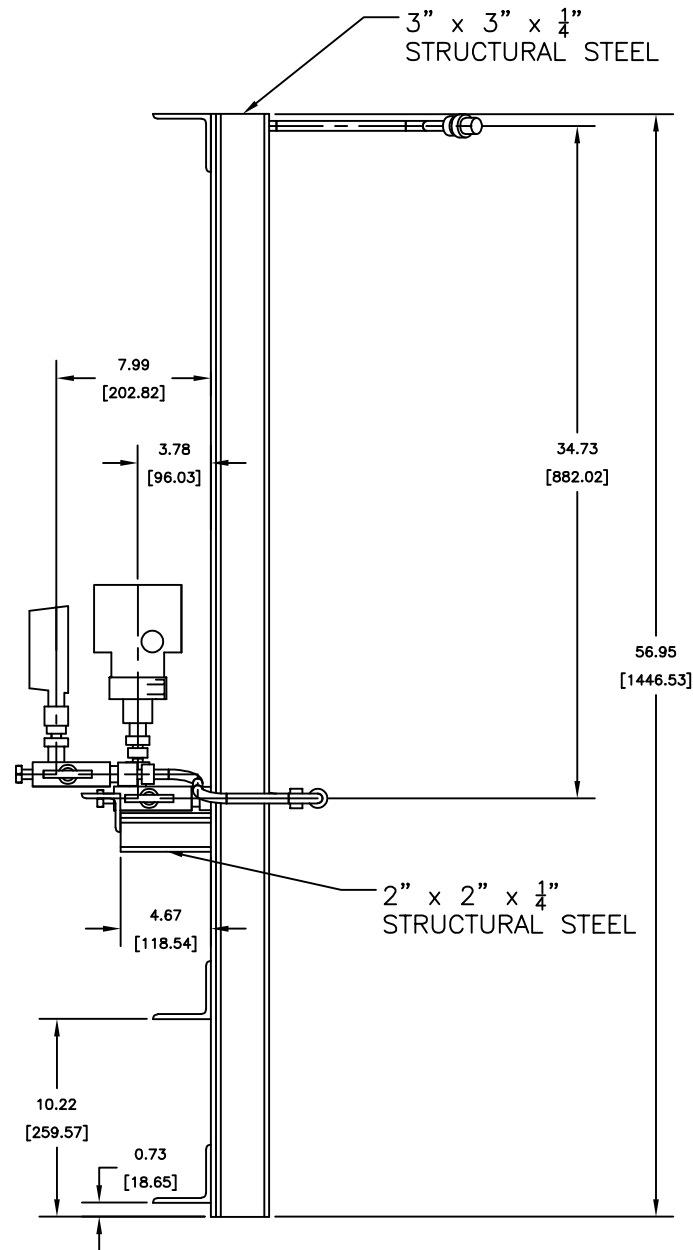
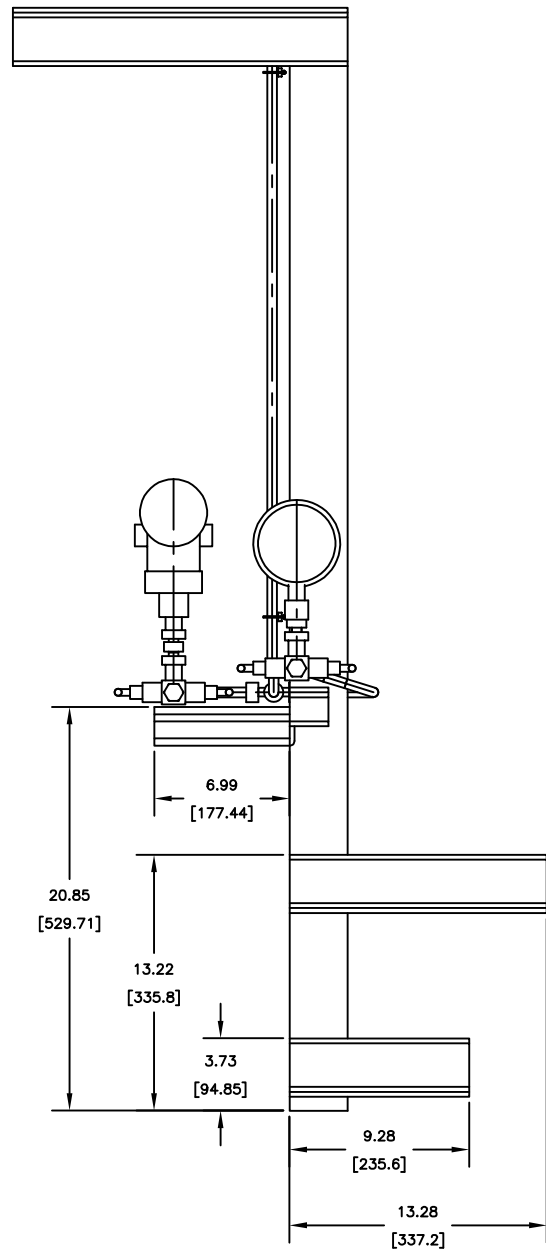

Code1	<input type="checkbox"/> No Comment/ Approved (Applicable Only for "FOR REVIEW" and "For Approval" Documents) No comment and the document are released for Manufacturing
Code2	<input type="checkbox"/> No Comment/ Approved with Note(s) Vendor/Sub-Contractor shall correct, revise and resubmit the document. The document is released for Manufacturing if changes incorporated.
Code3	<input type="checkbox"/> Commented Vendor/Sub-Contractor shall correct, revise and resubmit the document by the date specified. The document shall be revised under the Status of "To Revised Issue". All corrected documents shall be resubmitted before starting the Manufacturing Process
Code4	<input type="checkbox"/> Not Accepted (Rejected) Vendor/Sub-Contractor shall re-work/re-design/re-specify the contents of the document according to the comments/reasons for rejection. All corrected documents shall be resubmitted before starting the manufacturing. Vendor/Sub-Contractor shall not proceed with subsequent works of Material Supply or Manufacturing until receiving Code1/Code2 or No Code from PURCHASER. Vendor/Sub-Contractor shall resubmit the document with the same revision within 6 working days after receiving comments
No Code	<input type="checkbox"/> No Code (Only for "For Information" Documents and "As Built DWGs") Document has been submitted for PURCHASER's information (FI). Consistency, completeness and correctness of document content is in Vendor/Sub-Contractor's responsibility.

The above checking result by EED shall in no way relieve Vendor of any liability, obligation and responsibility out of the purchase order and the mutual agreement in writing

DATE :
DEPT :
Signature :

CV	PI	EL	IN	ME	MA
ST	BU	PR	SA	HV	TL

00	09-DEC-2025	IFI	D.SH	F.T	A.M
REV.	DATE (DD.MM.YY)	Purpose of Issue	Prepared	Checked	Approved
		Gachsaran Polymer Industries Company HDPE Plant			
PO No.: GPIC-PT-MA-PO-000-3029					SCALE: 1:1
DRAWING TITLE: Instruments Hookup Diagram and MTO					
DRAWING NO. VD-GPIC-MA-3029-3029-0051			REV.	SHEET NO.	SIZE
			00	11 of 17	A3

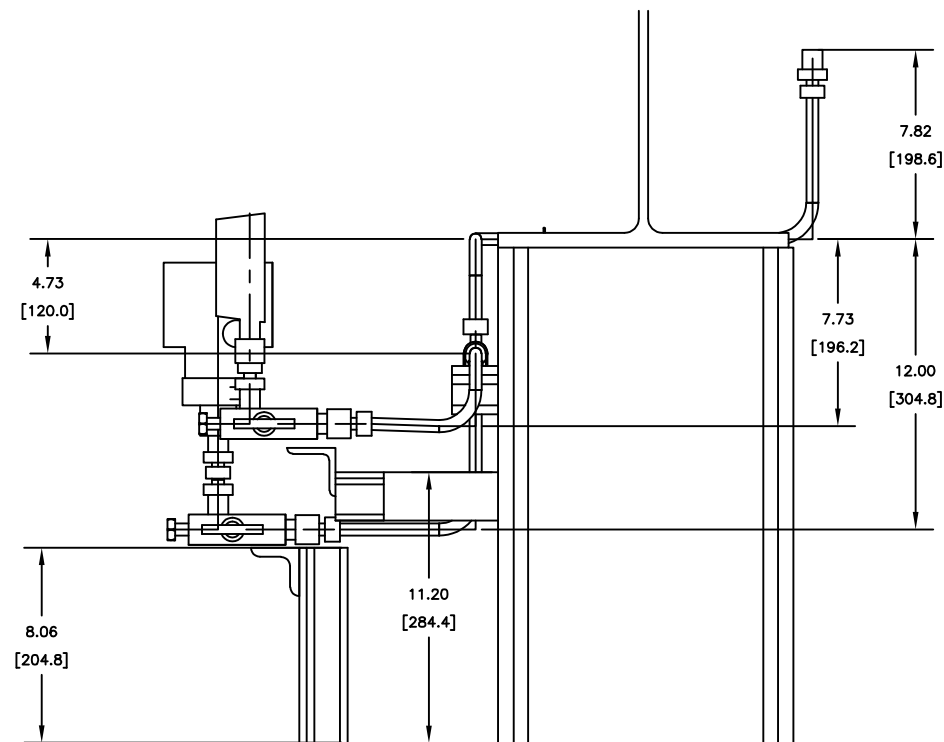
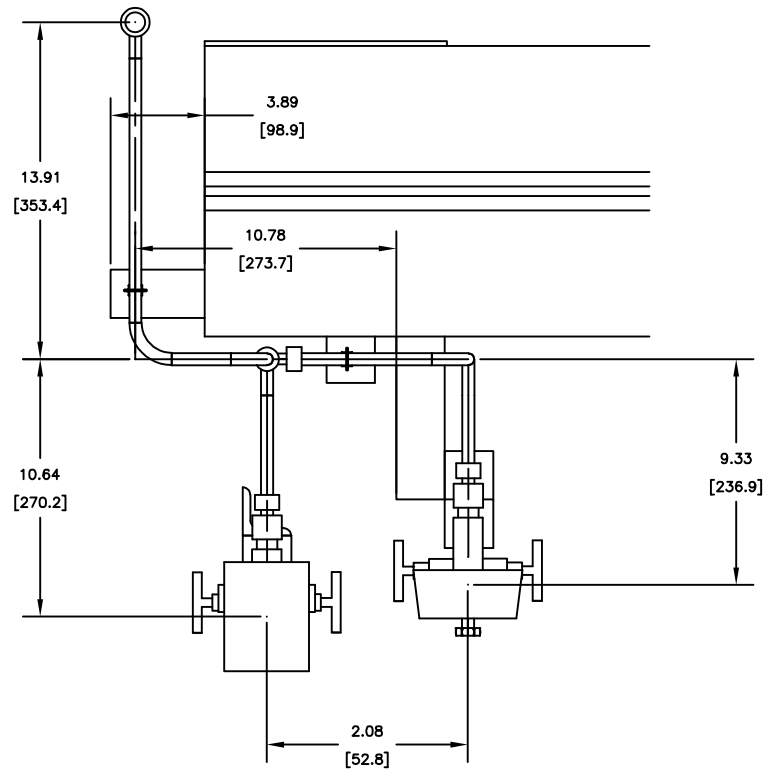

BILL OF MATERIALS			
PIPE			
ID	QTY	ND	DESCRIPTION
1	3'-2 3/4"	1/2"	TUBING, ASTM A269, SEAMLESS - 316SS
FITTINGS			
ID	QTY	ND	DESCRIPTION
2	6	1/2"	BEND 90 5R, TUBING, ASTM A269, 316SS
3	2	1/2"	PLUG, HEX HEAD, MPT, ASME B16.11
4	1	3/4"x1/2"	Male Connector 3/4" NPT(M) x 1/2" T
5	1	1/2"	Union_TEE_1/4" to 1"
VALVES			
ID	QTY	ND	DESCRIPTION
6	2	1/2"	2-Way-Manifold
PIPE SUPPORTS			
ID	QTY	ND	DESCRIPTION
7	2	1/2"	U-clamp

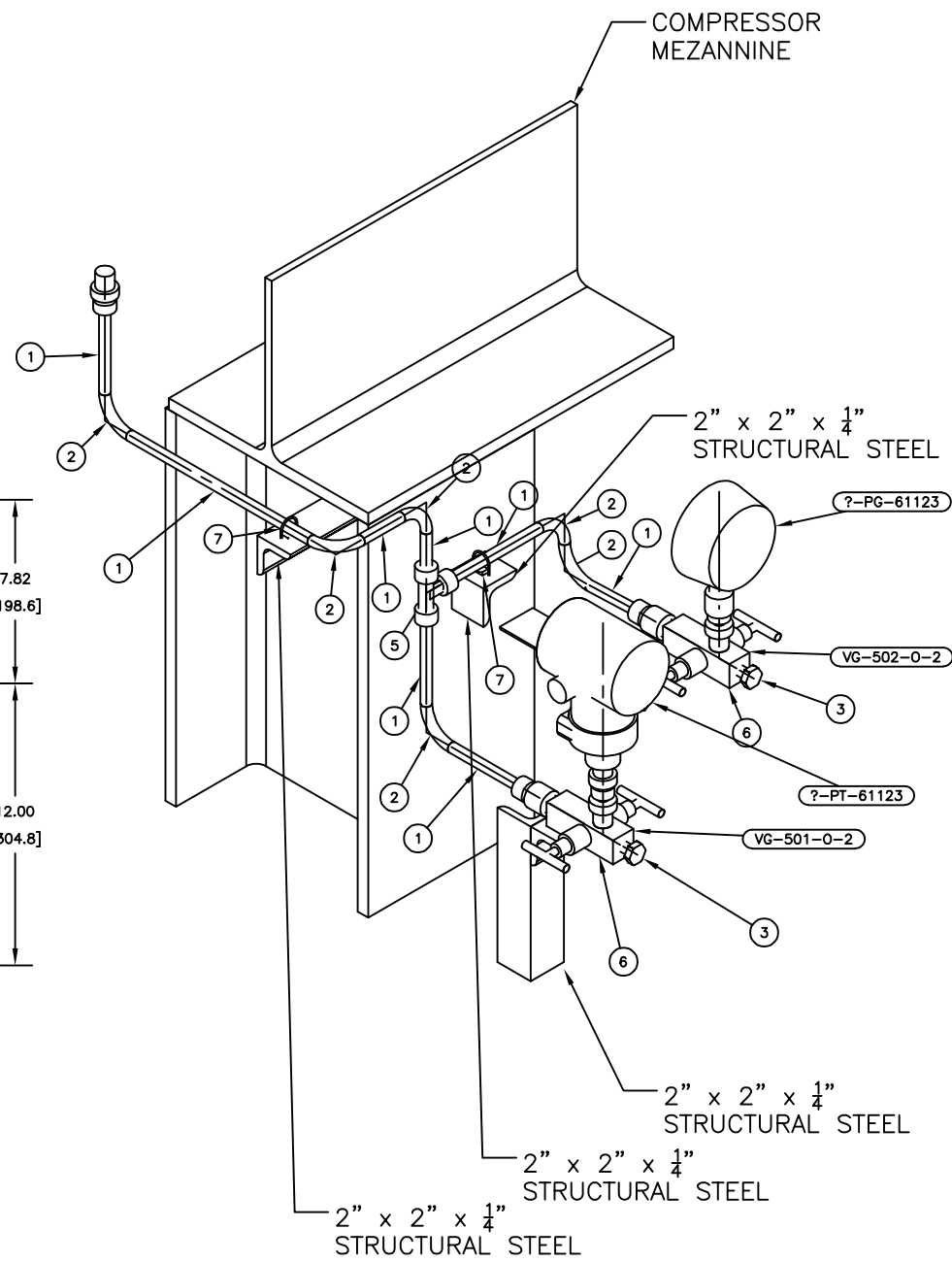

Code1	<input type="checkbox"/> No Comment/ Approved (Applicable Only for "FOR REVIEW" and "For Approval" Documents) No comment and the document are released for Manufacturing				
Code2	<input type="checkbox"/> No Comment/ Approved with Note(s) Vendor/Sub-Contractor shall correct, revise and resubmit the document. The document is released for Manufacturing if changes incorporated.				
Code3	<input type="checkbox"/> Commented Vendor/Sub-Contractor shall correct, revise and resubmit the document by the date specified. The document shall be revised under the Status of "R: Revised Issue". All corrected documents shall be resubmitted before starting the Manufacturing Process				
Code4	<input type="checkbox"/> Not Accepted (Rejected) Vendor/Sub-Contractor shall re-work/re-design/re-specify the contents of the document according to the comments/reasons for rejection. All corrected documents shall be resubmitted before starting the manufacturing. Vendor/Sub-Contractor shall not proceed with subsequent works of Material Supply or Manufacturing until receiving Code1/Code2 or No Code from PURCHASER. Vendor/Sub-Contractor shall resubmit the document with the same revision within 6 working days after receiving comments				
No Code	<input type="checkbox"/> No Code (Only for "For Information" Documents and "As Built DWGs") Document has been submitted for PURCHASER's information (FI). Consistency, completeness and correctness of document content is in Vendor/Sub-Contractor's responsibility.				
The above checking result by EIED shall in no way relieve Vendor of any liability, obligation and responsibility out of the purchase order and the mutual agreement in writing					
DATE : _____					
DEPT: _____					
Signature : _____					
CV	PI	EL	IN	ME	MA
ST	BU	PR	SA	HV	TL

00	09-DEC-2025	IFI	D.SH	F.T	A.M
REV.	DATE (DD.MM.YY)	Purpose of Issue	Prepared	Checked	Approved
		Gachsaran Polymer Industries Company HDPE Plant			
PO No.: GPIC-PT-MA-PO-000-3029					
DRAWING TITLE: Instruments Hookup Diagram and MTO					
DRAWING NO. VD-GPIC-MA-3029-3029-0051			REV.	SHEET NO.	SIZE
			00	12 of 17	A3

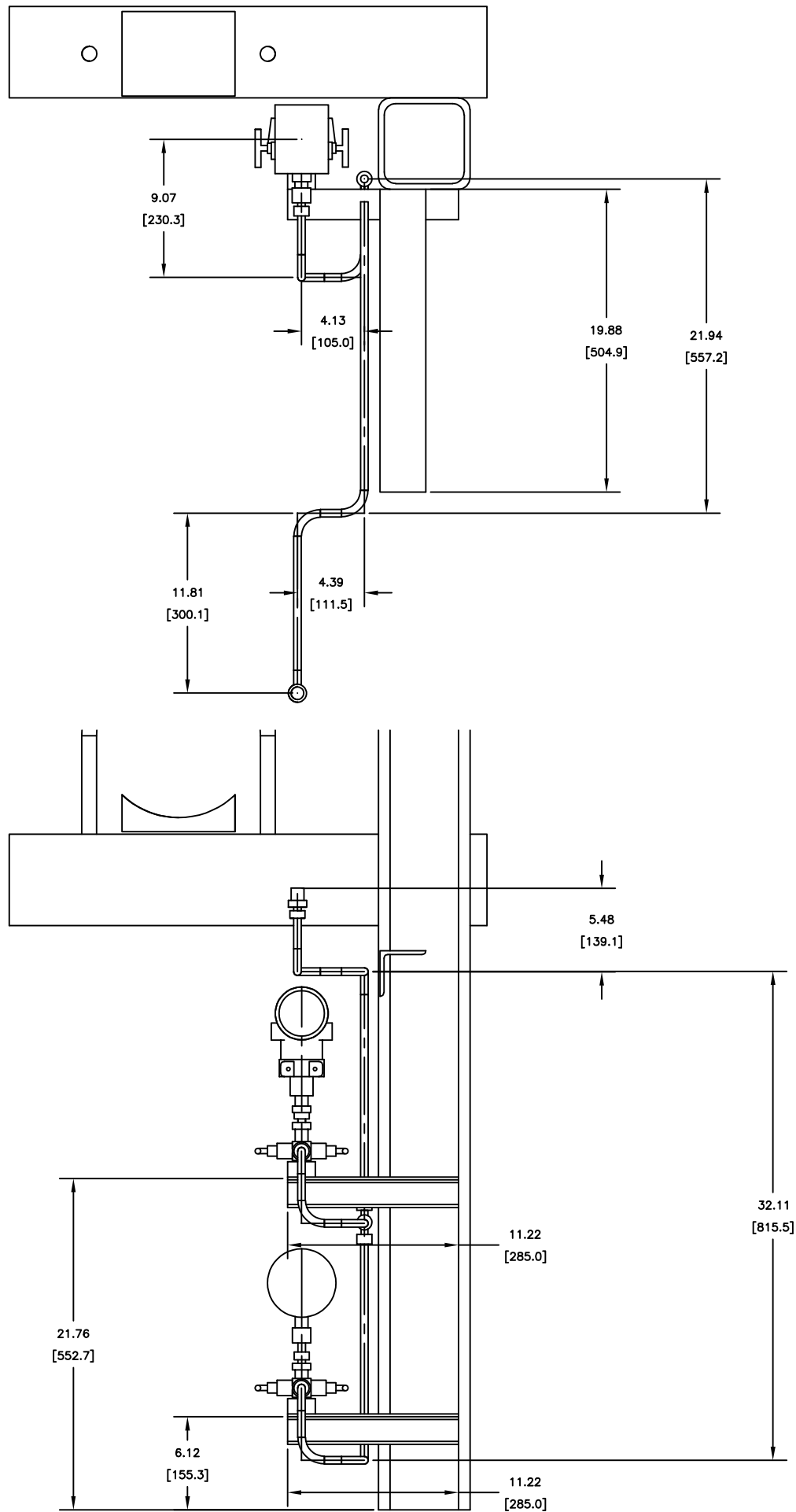

BILL OF MATERIALS			
PIPE			
ID	QTY	ND	DESCRIPTION
1	6'-5 5/16"	1/2"	TUBING, ASTM A269, SEAMLESS - 316SS
FITTINGS			
ID	QTY	ND	DESCRIPTION
2	11	1/2"	BEND 90 5R, TUBING, ASTM A269, 316SS
3	2	1/2"	PLUG, HEX HEAD, MPT, ASME B16.11
4	1	3/4"x1/2"	Male Connector 3/4" NPT(M) x 1/2" T
5	1	1/2"	Union_TEE_1/4" to 1"
VALVES			
ID	QTY	ND	DESCRIPTION
6	2	1/2"	2-Way-Manifold
PIPE SUPPORTS			
ID	QTY	ND	DESCRIPTION
7	1	10"	U-clamp

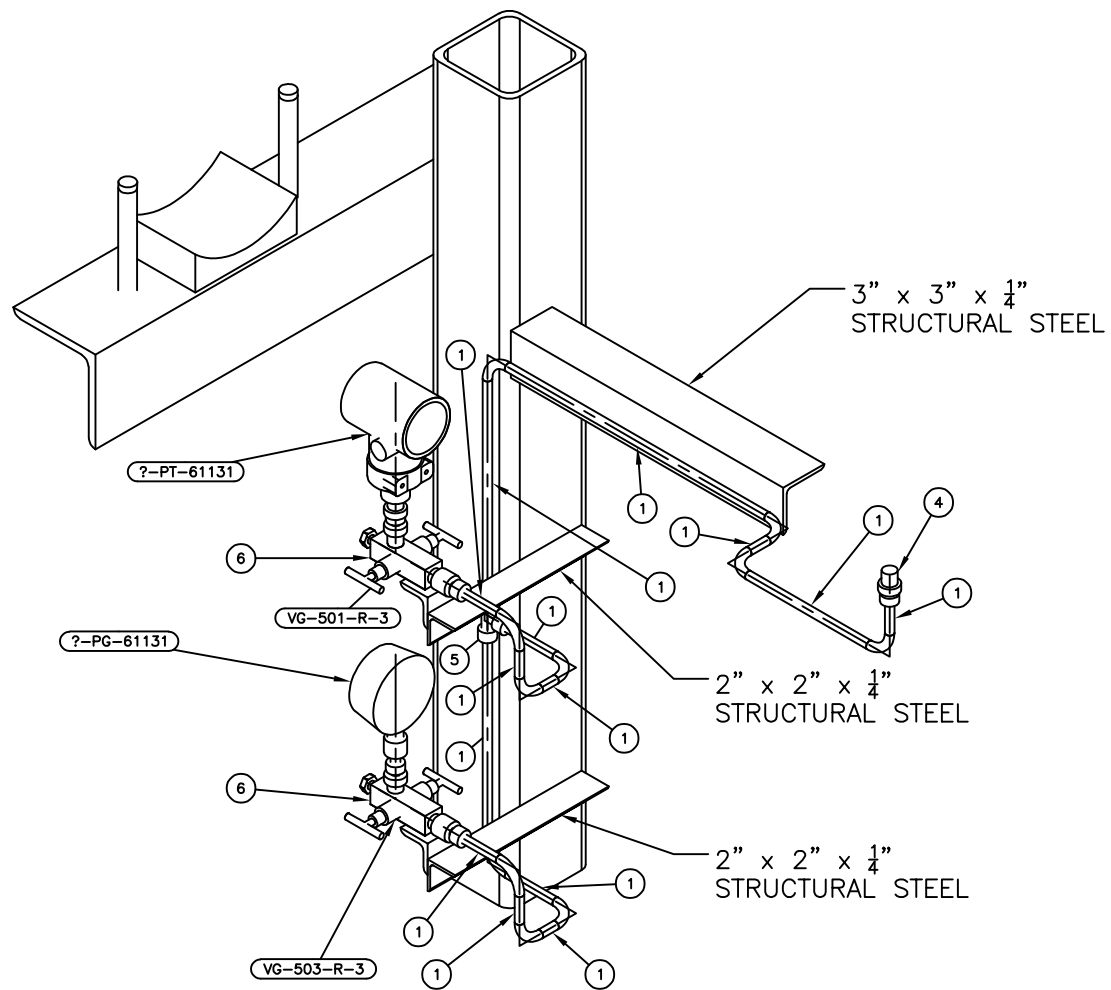

Code1	<input type="checkbox"/> No Comment/ Approved (Applicable Only for "FOR REVIEW" and "For Approval" Documents) No comment and the document are released for Manufacturing				
Code2	<input type="checkbox"/> No Comment/ Approved with Note(s) Vendor/Sub-Contractor shall correct, revise and resubmit the document. The document is released for Manufacturing if changes incorporated.				
Code3	<input type="checkbox"/> Commented Vendor/Sub-Contractor shall correct, revise and resubmit the document by the date specified. The document shall be revised under the Status of "Re Revised Issue". All corrected documents shall be resubmitted before starting the Manufacturing Process				
Code4	<input type="checkbox"/> Not Accepted (Rejected) Vendor/Sub-Contractor shall re-work/re-design/re-specify the contents of the document according to the comments/reasons for rejection. All corrected documents shall be resubmitted before starting the manufacturing process. Sub-Contractor shall not proceed with subsequent works of Material Supply or Manufacturing until receiving Code1/Code2 or No Code from PURCHASER. Vendor/Sub-Contractor shall resubmit the document with the same revision within 6 working days after receiving comments				
No Code	<input type="checkbox"/> No Code (Only for "For Information" Documents and "As Built DWG") Document has been submitted for PURCHASER'S information (VI). Consistency, completeness and correctness of document content is the Vendor/Sub-Contractor's responsibility.				
The above checking result by EIED shall in no way relieve Vendor of any liability, obligation and responsibility out of the purchase order and the mutual agreement in writing					
DATE :					
DEPT :					
Signature :					
CV	PI	EL	IN	ME	MA
ST	BU	PR	SA	HV	TL

00	09-DEC-2025	IFI	D.SH	F.T	A.M
REV.	DATE (DD.MM.YY)	Purpose of Issue	Prepared	Checked	Approved
		Gachsaran Polymer Industries Company HDPE Plant			
PO No.: GPIC-PT-MA-PO-000-3029					SCALE: 1:1
DRAWING TITLE: Instruments Hookup Diagram and MTO					
DRAWING NO. VD-GPIC-MA-3029-3029-0051			REV. 00	SHEET NO. 13 of 17	SIZE A3

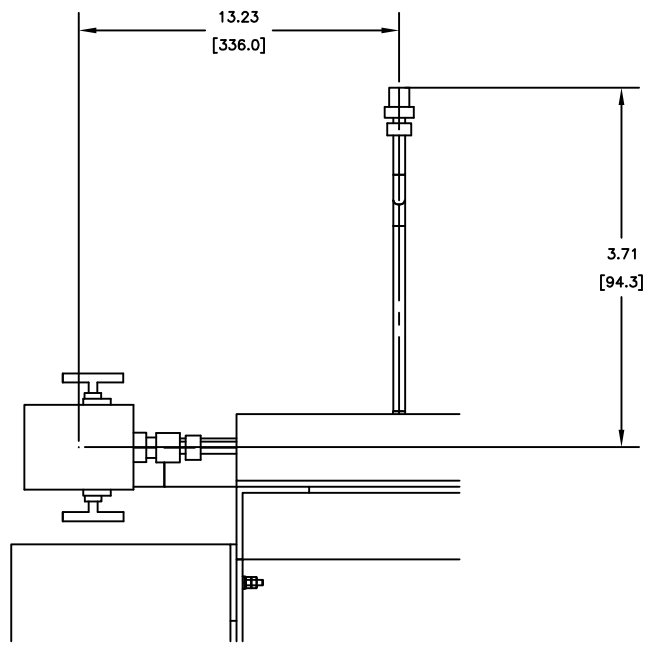

BILL OF MATERIALS			
PIPE			
ID	QTY	ND	DESCRIPTION
1	1'-4 7/16"	1/2"	TUBING, ASTM A269, SEAMLESS - 316SS
FITTINGS			
ID	QTY	ND	DESCRIPTION
2	2	1/2"	BEND 45 5R, TUBING, ASTM A269, 316SS
3	1	1/2"	BEND 90 5R, TUBING, ASTM A269, 316SS
4	1	1/2"	PLUG, HEX HEAD, MPT, ASME B16.11
VALVES			
ID	QTY	ND	DESCRIPTION
5	1	1/2"	2-Way-Manifold

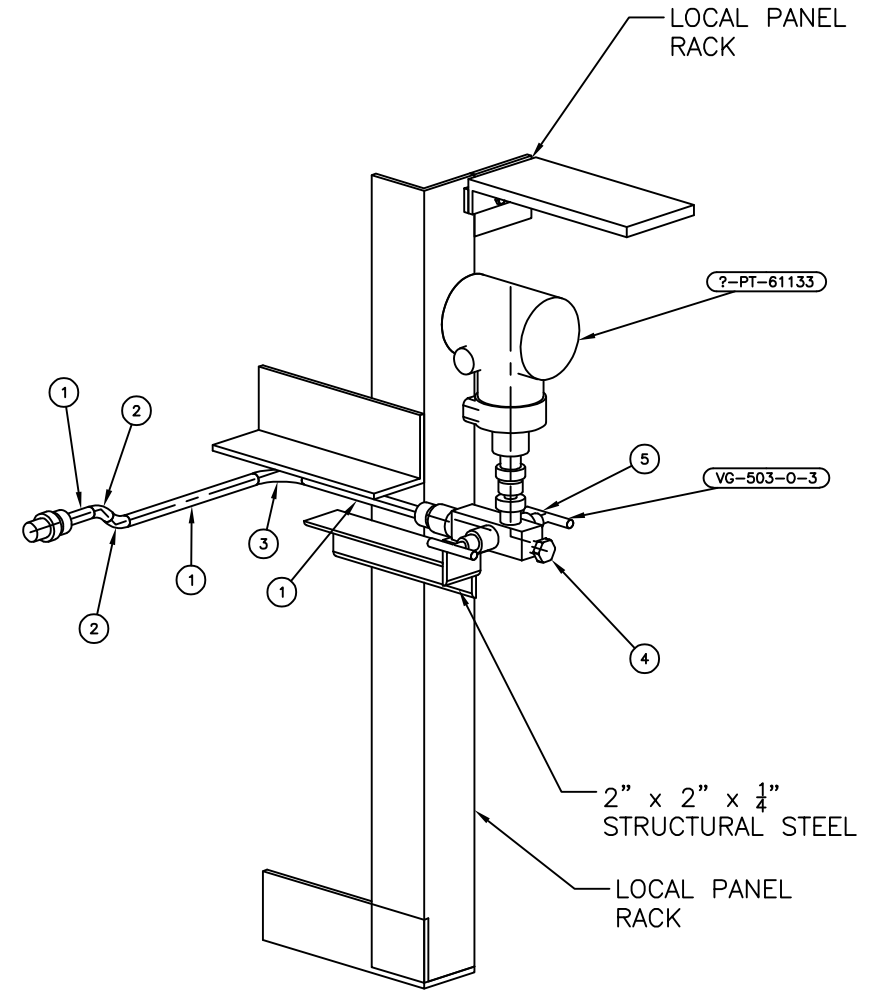
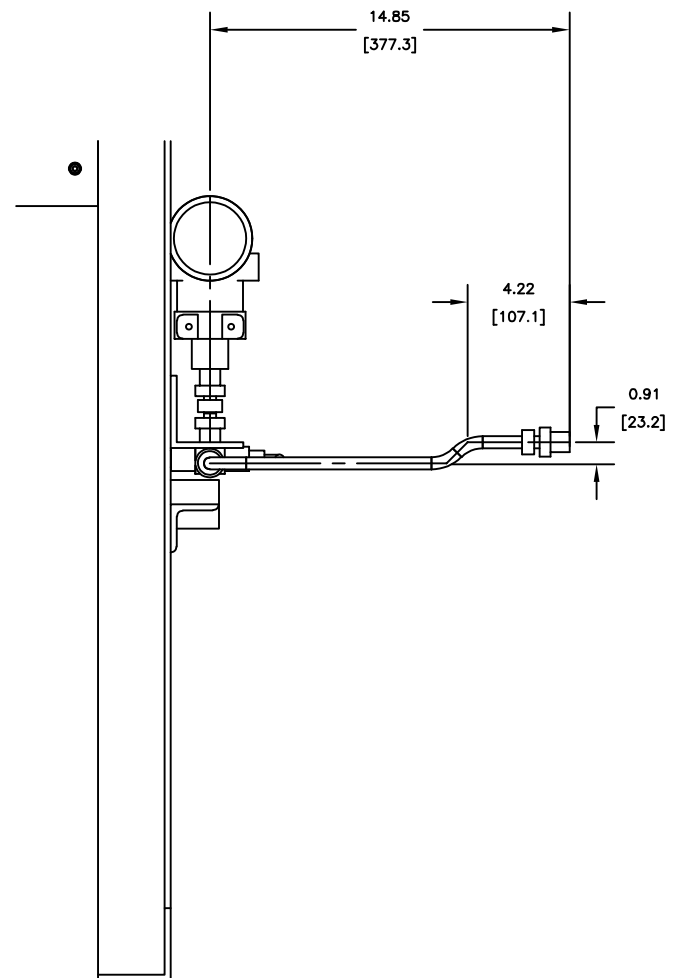
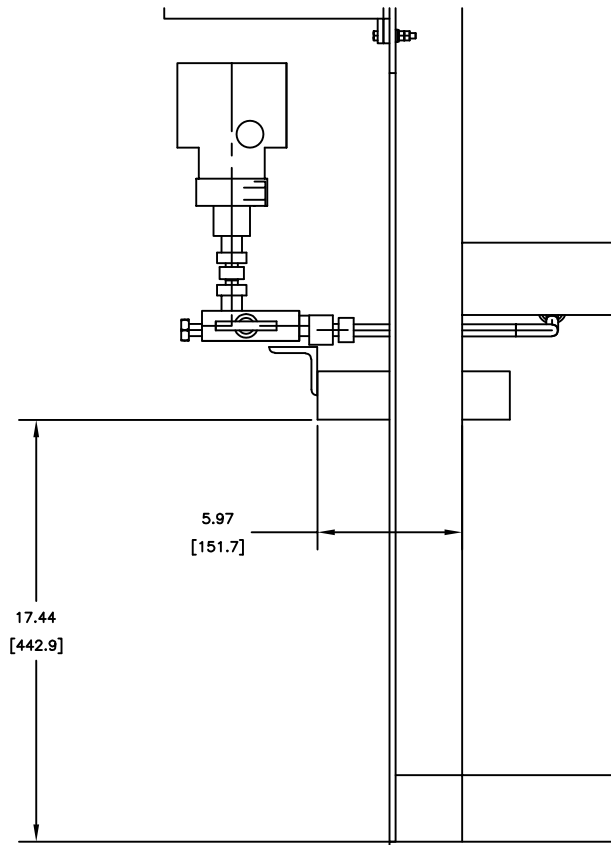

Code1	<input type="checkbox"/> No Comment/ Approved (Applicable Only for "FOR REVIEW" and "For Approval" Documents) No comment and the document are released for Manufacturing
Code2	<input type="checkbox"/> No Comment/ Approved with Note(s) Vendor/Sub-Contractor shall correct, revise and resubmit the document. The document is released for Manufacturing if changes incorporated.
Code3	<input type="checkbox"/> Commented Vendor/Sub-Contractor shall correct, revise and resubmit the document by the date specified. The document shall be revised under the Status of "To Be Revised Issue". All corrected documents shall be resubmitted before starting the Manufacturing Process
Code4	<input type="checkbox"/> Not Accepted (Rejected) Vendor/Sub-Contractor shall re-work/re-design/re-specify the contents of the document according to the comments/ reasons for rejection. All corrected documents shall be resubmitted before starting the manufacturing. Vendor Sub-Contractor shall not proceed with subsequent works of Material Supply or Manufacturing until receiving Code1/Code2 or No Code from PURCHASER. Vendor/Sub-Contractor shall resubmit the document with the same revision within 6 working days after receiving comments
No Code	<input type="checkbox"/> No Code (Only for "For Information" Documents and "As Built DWGs") Document has been submitted for PURCHASER's information (I). Consistency, completeness and correctness of document content is in Vendor/Sub-Contractor's responsibility.

The above checking result by EIED shall in no way relieve Vendor of any liability, obligation and responsibility out of the purchase order and the mutual agreement in writing

DATE :	
DEPT :	
Signature :	

CV	PI	EL	IN	ME	MA
ST	BU	PR	SA	HV	TL

00	09-DEC-2025	IFI	D.SH	F.T	A.M
REV.	DATE (DD.MM.YY)	Purpose of Issue	Prepared	Checked	Approved
		Gachsan Polymer Industries Company HDPE Plant			
PO No.: GPIC-PT-MA-PO-000-3029					
DRAWING TITLE: Instruments Hookup Diagram and MTO					
DRAWING NO. VD-GPIC-MA-3029-3029-0051			REV.	SHEET NO.	SIZE
			00	14 of 17	A3

BILL OF MATERIALS			
PIPE			
ID	QTY	ND	DESCRIPTION
1	2'-9 5/8"	1/2"	TUBING, ASTM A269, SEAMLESS - 316SS
FITTINGS			
ID	QTY	ND	DESCRIPTION
2	2	1/2"	BEND 90 5R, TUBING, ASTM A269, 316SS
3	1	1/2"	PLUG, HEX HEAD, MPT, ASME B16.11
VALVES			
ID	QTY	ND	DESCRIPTION
4	1	1/2"	2-Way-Manifold
PIPE SUPPORTS			
ID	QTY	ND	DESCRIPTION
5	1	1/2"	U-clamp

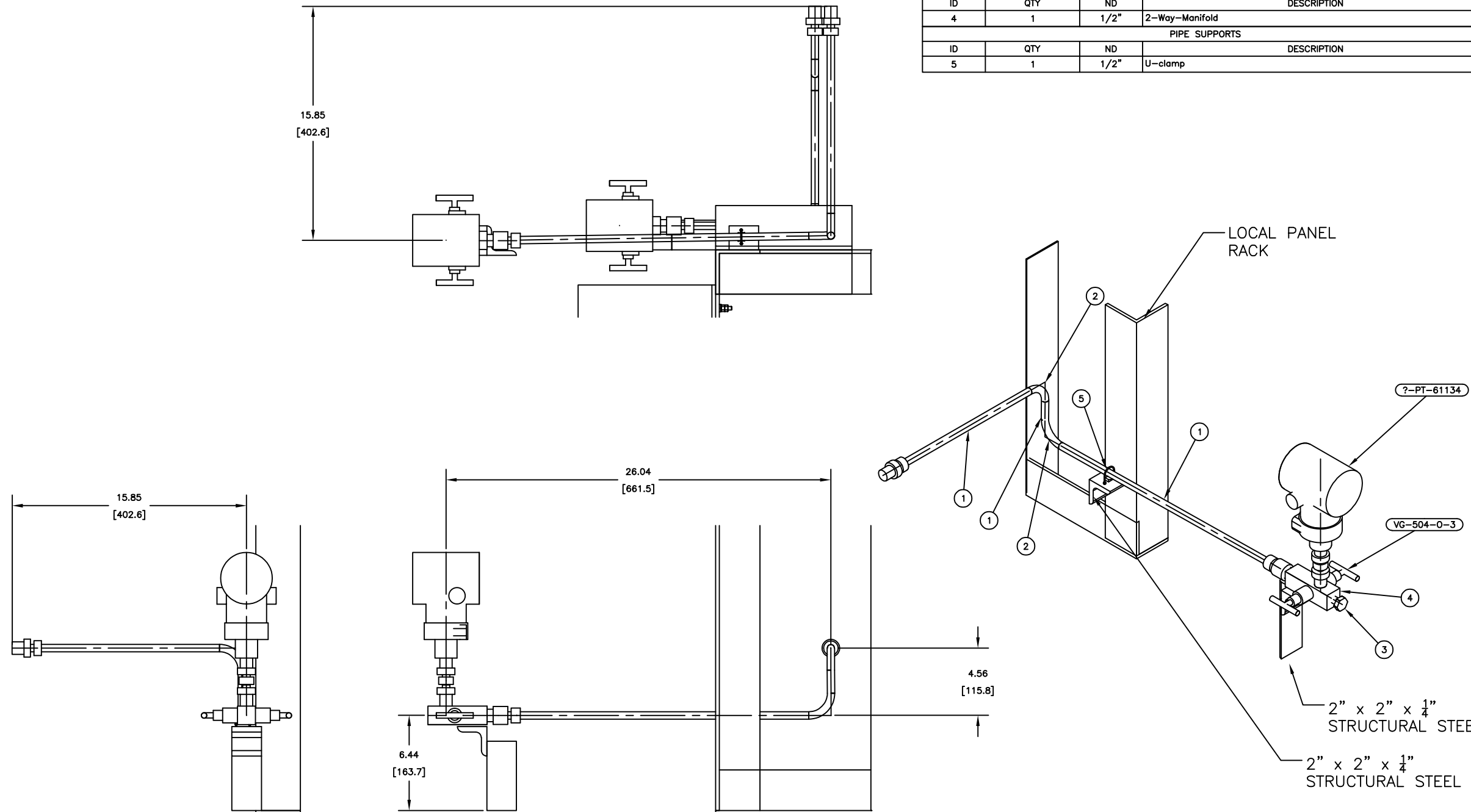





Code1	<input type="checkbox"/> No Comment/ Approved (Applicable Only for "FOR REVIEW" and "For Approval" Documents) No comment and the document are released for Manufacturing
Code2	<input type="checkbox"/> No Comment/ Approved with Note(s) Vendor/Sub-Contractor shall correct, revise and resubmit the document. The document is released for Manufacturing if changes incorporated.
Code3	<input type="checkbox"/> Commented Vendor/Sub-Contractor shall correct, revise and resubmit the document by the date specified. The document shall be revised under the Status of "To: Revised Issue". All corrected documents shall be resubmitted before starting the Manufacturing Process
Code4	<input type="checkbox"/> Not Accepted (Rejected) Vendor/Sub-Contractor shall re-work/re-design/re-specify the contents of the document according to the comments/reasons for rejection. All corrected documents shall be resubmitted before starting the manufacturing. Vendor/Sub-Contractor shall not proceed with subsequent works of Material Supply or Manufacturing until receiving Code1/Code2 or No Code from PURCHASER. Vendor/Sub-Contractor shall resubmit the document with the same revision within 6 working days after receiving comments.
No Code	<input type="checkbox"/> No Code (Only for "For Information" Documents and "As Built (DWG)" Document has been submitted for PURCHASER'S Information (I). Consistency, completeness and correctness of document content is in Vendor/Sub-Contractor's responsibility.

The above checking result by EIED shall in no way relieve Vendor of any liability, obligation and responsibility out of the purchase order and the mutual agreement in writing

DATE :
DEPT :
Signature :

CV	PI	EL	IN	ME	MA
ST	BU	PR	SA	HV	TL

00	09-DEC-2025	IFI	D.SH	F.T	A.M
REV.	DATE (DD.MM.YY)	Purpose of Issue	Prepared	Checked	Approved
 		Gacharan Polymer Industries Company HOPE Plant		 	
PO No.: GPIC-PT-MA-PO-000-3029					SCALE: 1:1
DRAWING TITLE: Instruments Hookup Diagram and MTO					
DRAWING NO. VD-GPIC-MA-3029-3029-0051		REV.	SHEET NO.	SIZE	
		00	15 of 17	A3	

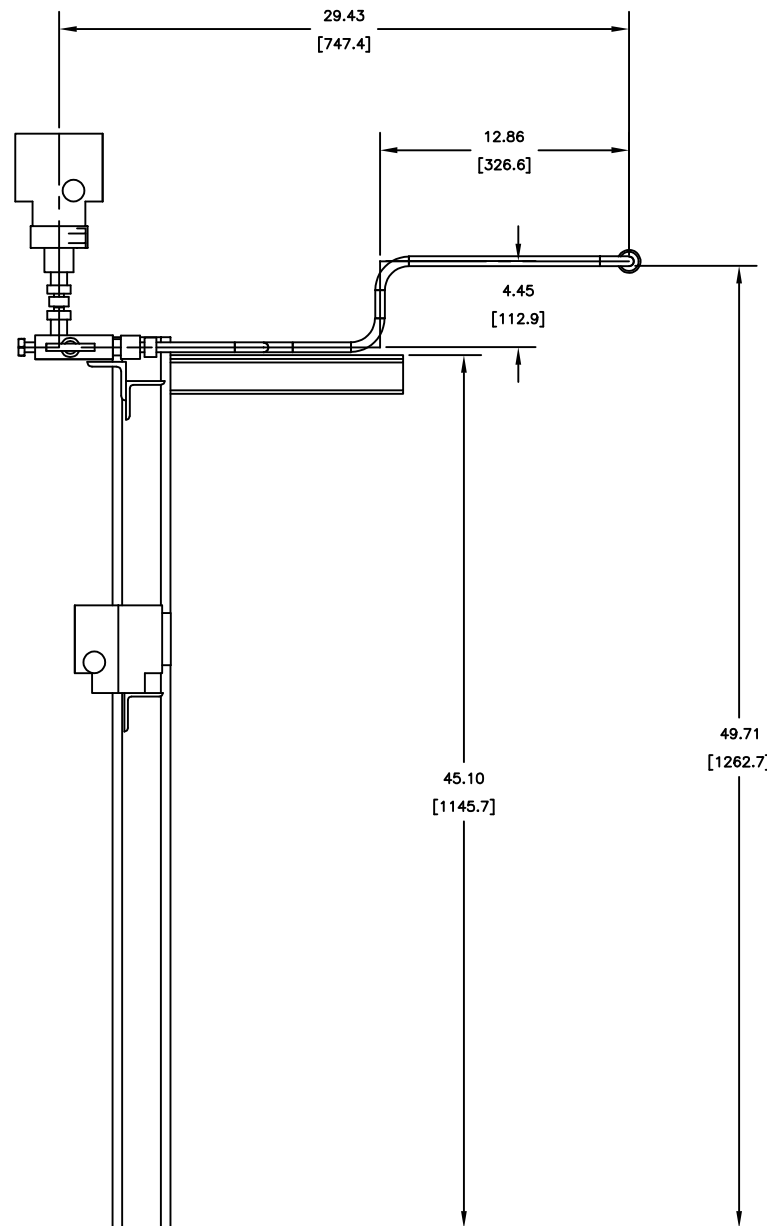
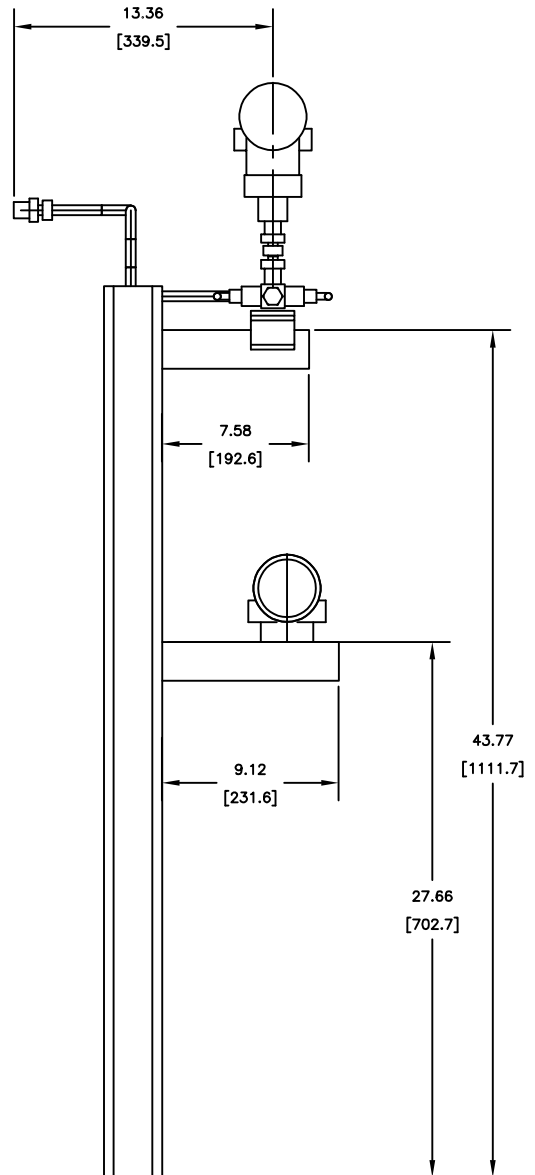
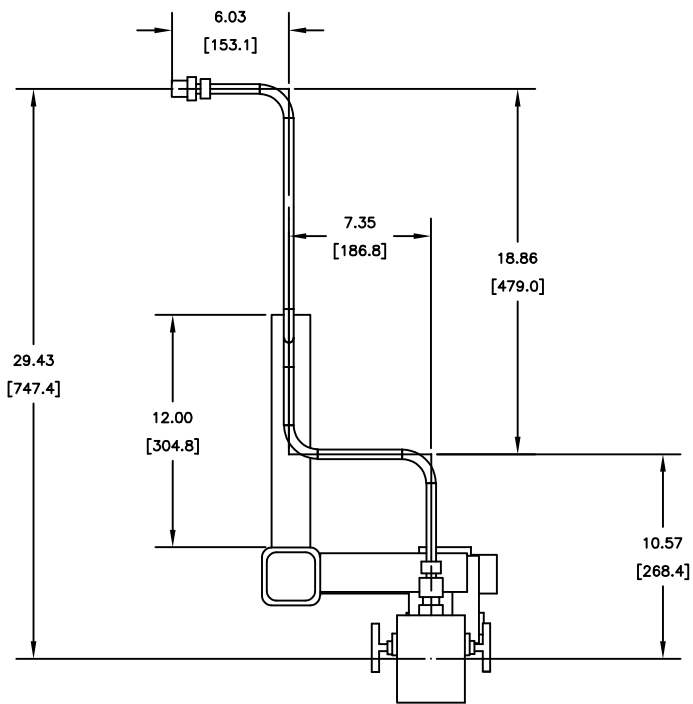

BILL OF MATERIALS				
PIPE				
ID	QTY	ND	DESCRIPTION	
1	2'-2"	1/2"	TUBING, ASTM A269, SEAMLESS -- 316SS	
FITTINGS				
ID	QTY	ND	DESCRIPTION	
2	5	1/2"	BEND 90 5R, TUBING, ASTM A269, 316SS	
3	1	1/2"	PLUG, HEX HEAD, MPT, ASME B16.11	
4	1	3/4"x1/2"	Male Connector 3/4" NPT(M) x 1/2" T	
VALVES				
ID	QTY	ND	DESCRIPTION	
5	1	1/2"	2-Way-Manifold	

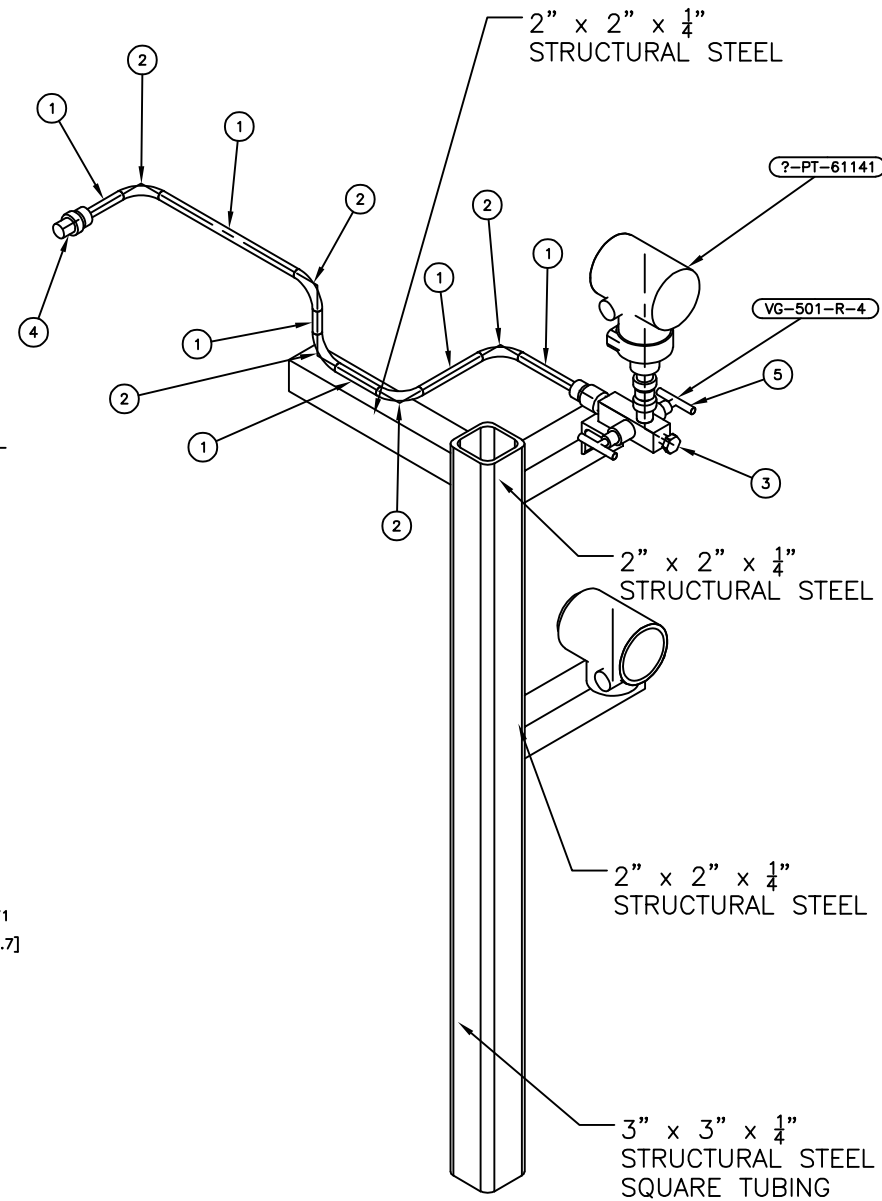

Code1	<input type="checkbox"/> No Comment/ Approved (Applicable Only for "FOR REVIEW" and "For Approval" Documents) No comment and the document are released for Manufacturing
Code2	<input type="checkbox"/> No Comment/ Approved with Note(s) Vendor/Sub-Contractor shall correct, revise and resubmit the document. The document is released for Manufacturing if changes incorporated.
Code3	<input type="checkbox"/> Commented Vendor/Sub-Contractor shall correct, revise and resubmit the document by the date specified. The document shall be revised under the Status of "R: Revised Issue". All corrected documents shall be resubmitted before starting the Manufacturing Process
Code4	<input type="checkbox"/> Not Accepted (Rejected) Vendor/Sub-Contractor shall re-work/re-design/re-specify the contents of the document according to the comments/reasons for rejection. All corrected documents shall be resubmitted before starting the manufacturing. Vendor/Sub-Contractor shall not proceed with subsequent works of Material Supply or Manufacturing until receiving Code/Code2 or No Code from PURCHASER. Vendor/Sub-Contractor shall resubmit the document with the same revision within 6 working days after receiving comments
No Code	<input type="checkbox"/> No Code (Only for "For Information" Documents and "As Built DWGs") Document has been submitted for PURCHASER'S information (I). Consistency, completeness and correctness of document content is in Vendor/Sub-Contractor's responsibility.

The above checking result by EIED shall in no way relieve Vendor of any liability, obligation and responsibility out of the purchase order and the mutual agreement in writing

EIED		DATE :	
		DEPT:	
		Signature :	
CV	PI	EL	IN
ST	BU	PR	SA
		ME	MA
		HV	TL

00	09-DEC-2025	IFI	D.SH	F.T	A.M
REV.	DATE (DD.MM.YY)	Purpose of Issue	Prepared	Checked	Approved
		Gachsaran Polymer Industries Company HOPE Plant			
PO No.: GPIC-PT-MA-PO-000-3029					SCALE: 1:1
DRAWING TITLE: Instruments Hookup Diagram and MTO					
DRAWING NO. VD-GPIC-MA-3029-3029-0051			REV. 00	SHEET NO. 16 of 17	SIZE A3

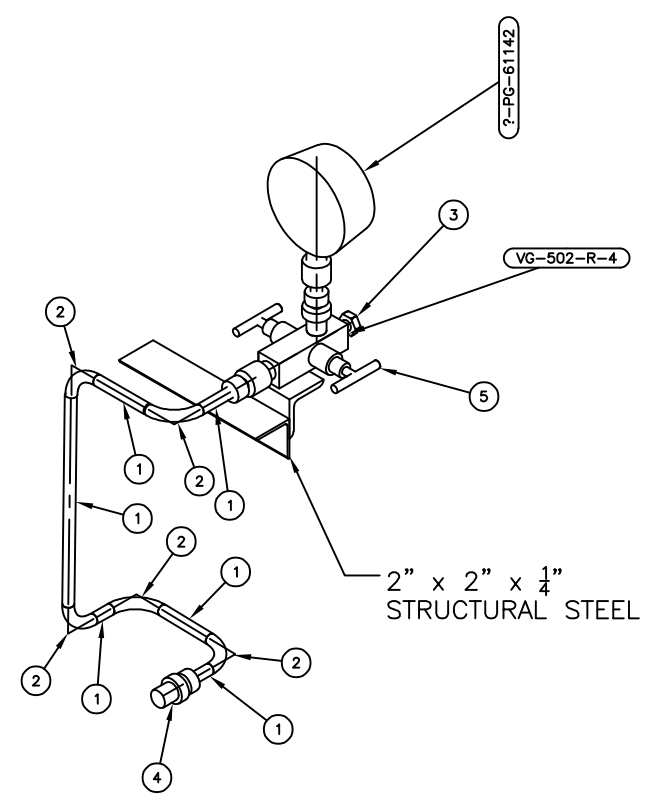
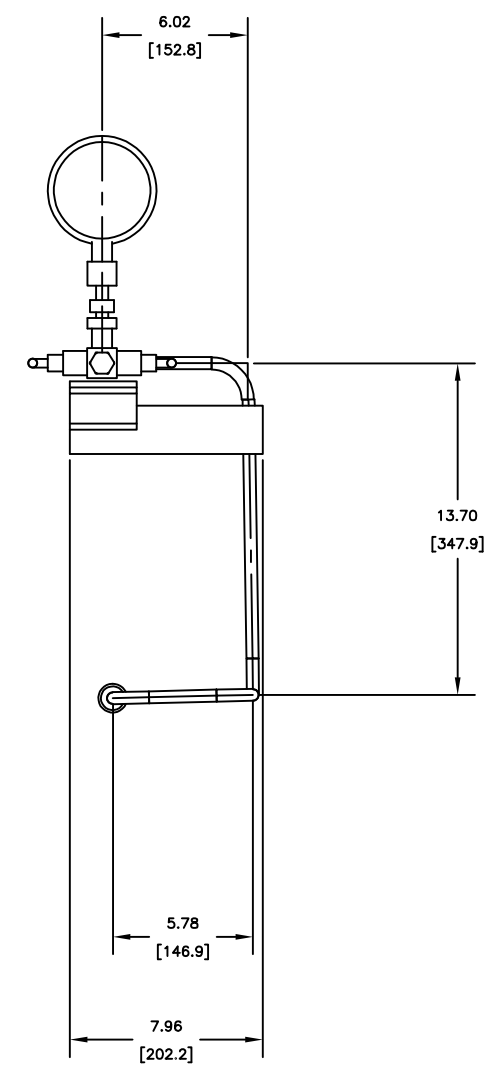
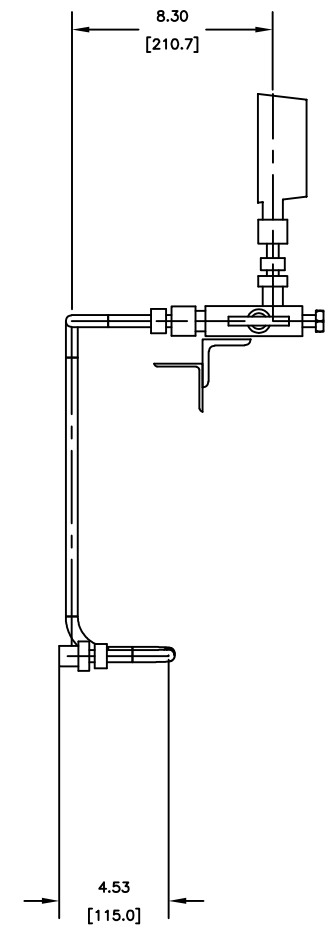
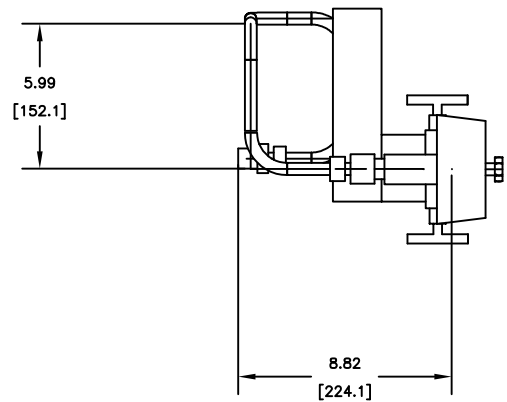

BILL OF MATERIALS				
PIPE				
ID	QTY	ND	DESCRIPTION	
1	1'-8	15/16"	1/2"	TUBING, ASTM A269, SEAMLESS - 316SS
FITTINGS				
ID	QTY	ND	DESCRIPTION	
2	5	1/2"	BEND 90 5R, TUBING, ASTM A269, 316SS	
3	1	1/2"	PLUG, HEX HEAD, MPT, ASME B16.11	
4	1	3/4"x1/2"	Male Connector 3/4" NPT(M) x 1/2" T	
VALVES				
ID	QTY	ND	DESCRIPTION	
5	1	1/2"	2-Way-Manifold	

Code1	<input type="checkbox"/> No Comment/ Approved (Applicable Only for "FOR REVIEW" and "For Approval" Documents) No comment and the document are released for Manufacturing				
Code2	<input type="checkbox"/> No Comment/ Approved with Note(s) Vendor/Sub-Contractor shall correct, revise and resubmit the document. The document is released for Manufacturing if changes incorporated.				
Code3	<input type="checkbox"/> Commented Vendor/Sub-Contractor shall correct, revise and resubmit the document by the date specified. The document shall be revised under the Status of "Revised Issue". All corrected documents shall be resubmitted before starting the Manufacturing Process				
Code4	<input type="checkbox"/> Not Accepted (Rejected) Vendor/Sub-Contractor shall re-work/re-design/re-specify the contents of the document according to the comments/reasons for rejection. All corrected documents shall be resubmitted before starting the manufacturing. Vendor Sub-Contractor shall not proceed with subsequent works of Material Supply or Manufacturing until receiving Code1/Code2 or No Code from PURCHASER. Vendor/Sub-Contractor shall resubmit the document with the same revision within 6 working days after receiving comments				
No Code	<input type="checkbox"/> No Code (Only for "For Information" Documents and "As Built DWGs") Document has been submitted for PURCHASER's information (FI). Consistency, completeness and correctness of document content is in Vendor/Sub-Contractor's responsibility.				
The above checking result by EED shall in no way relieve Vendor of any liability, obligation and responsibility out of the purchase order and the mutual agreement in writing.					
DATE :					
DEPT:					
Signature :					
CV	FI	EL	IN	ME	MA
ST	BU	PR	SA	HV	TL

00	09-DEC-2025	IFI	D.SH	F.T	A.M
REV.	DATE (DD.MM.YY)	Purpose of Issue	Prepared	Checked	Approved
		Gachsaran Polymer Industries Company HDPE Plant			
PO No.: GPIC-PT-MA-PO-000-3029					SCALE: 1:1
DRAWING TITLE: Instruments Hookup Diagram and MTO					
DRAWING NO. VD-GPIC-MA-3029-3029-0051			REV. 00	SHEET NO. 17 of 17	SIZE A3