



LIDCO, Pars SEE Zone, Assaluyeh,
Integrated Methanol and Ammonia
Plant 3000 MTPD MeOH / 900 MTPD NH3 PROJECT



Detail Drawings for Coolers

Document No. 17735-23A

Project No.	Vendor Doc.	P.O. No.	Department	Document Type	Serial No	Revision	Page
N278	VD	6019	ME	DWG	0024	04	Page 1 of 4

**Airpack B.V. - Air Compressor –
Integrated Methanol and Ammonia Plant
17735-COM Detail Drawings for Coolers (K020)**

04	08-05-2024	Issued for Information	S.K.	J.J.	S.K.
03	25-04-2024	Issued for Information	S.K.	J.J.	S.K.
02	12-02-2024	Issued for Information	S.K.	J.J.	S.K.
01	13-12-2023	Issued for Information	S.K.	J.J.	S.K.
REV.	DATE	DESCRIPTION	DRAWN	CHECKED	APPROVED

This document has been produced by Contractor for LIDCO. It is confidential and cannot be disclosed to or used by any third party for any purpose without prior written consent.

Detail Drawings for Coolers

Document No. 17735-23A

Project No.	Vendor Doc.	P.O. No.	Department	Document Type	Serial No	Revision	Page
N278	VD	6019	ME	DWG	0024	04	Page 2 of 4

LIST OF REVISED PAGES

Rev. Page	01	02	03	04	05	Rev. Page	01	02	03	04	05	Rev. Page	01	02	03	04	05	Rev. Page	01	02	03	04	05
1	X	X	X	X		26						51						76					
2	X	X	X	X		27						52						77					
3	X	X	X	X		28						53						78					
4		X	X	X		29						54						79					
5			X			30						55						80					
6						31						56						81					
7						32						57						82					
8						33						58						83					
9						34						59						84					
10						35						60						85					
11						36						61						86					
12						37						62						87					
13						38						63						88					
14						39						64						89					
15						40						65						90					
16						41						66						91					
17						42						67						98					
18						43						68						ATTACHMENT					
19						44						69						1					
20						45						70						2					
21						46						71						3					
22						47						72						4					
23						48						73						5					
24						49						74						6					
25						50						75						7					

Nozzle Table / Stutzentabelle		
No. / Nr.	Function / Funktion	Size / Größe
N1	Tubeside In	G 3/4" - integrated in header
N2	Tubeside Out	G 3/4" - integrated in header
N3	Shellside In	ASME B16.5 - 3/4" - Class 600 - WNRF - Schedule 80
N4	Shellside Out	ASME B16.5 - 3/4" - Class 600 - WNRF - Schedule 80
N5	Tubeside Drain/Vent	G 1/4" - integrated in header
N6	Shellside Drain	G 1/2"
N7	Shellside Vent	G 1/2"

Design Parameters
Design Bedingungen

TEMA Class/Type TEMA Klasse/Typ	Class C - Type BEW	
Mech. Design Code Konstruktionsvorschrift	ASME VIII Div.1:2023	
Code Case(s) Code Case(s)	none	
Lethal Service Tödliche/Giftige Medien	no	
Impact Test Req. Kerbschlagversuch	no per UHA-51 (d)	
PWHT Wärmebehandlung	none	
Loadings acc. UG-22 Lasten gem. UG-22	(a), (b), (d)(2), (j)	
Wind Loads Windlasten	none considered	
Seismic Loads Erdbebenlasten	none considered	
Operating Medium Betriebsmedium	Tubeside Rohrseite	Water
	Shellside Mantel­seite	Air
Volume (V) Volumen	0,8L	1,7L
Design Pressure (MAWP) Max. zul. Druck (MAWP) / (PS)	-1/10bar(g)	-1/39bar(g)
Test Pressure (PT) Prüfdruck	15bar(g)	64,35bar(g)
Design Temperature (AT) Zul. Betriebstemperatur (AT) / (TS)	-10/100°C	-10/175°C
Corrosion Allowance Korrosionszuschlag	0mm	0mm
Number of Passes Anzahl der Wege	2	1
Weld Joint Efficiency Schweißnahtfaktor	0,85	

Job Information Auftragsinformationen		Certification / Registration Zertifizierung / Registrierung		
IWS Item No. IWS Artikel Nr.	704233207	<input checked="" type="checkbox"/> ASME VIII Div. 1	U-Stamp	no
IWS Project No. IWS Projekt Nr.	104234198		NB Registration	no
Serial No. Serien Nr.	See Table	General Information Allgemeine Informationen		
Customer Item No. Kunden Artikel Nr.	See Table	Nondestructive Testing Zerstörungsfreie Prüfungen	Pressure test and RT acc. to ASME code.	
Corresponding Documents Zugehörige Dokumente		Surface Treatment Oberflächenbehandlung	pickled and passivated	
Strength Calculation Festigkeitsberechnung	BZ-704233207	Operating Weight Betriebsgewicht	ca. 15,8kg	
Weld- and Test Plan Schweiß- und Prüfplan	SZ-704233207	Hydrostatic Test Weight Wasserdruckprüfungsgewicht	ca. 17,5kg	
Parts List Stückliste	Sheet 2	Empty Weight Leergewicht	ca. 15kg	

Revisions Revisionen					
Rev.	Reason for Issue Grund der Ausgabe	Date Datum	Drawn Gezeichnet	Checked Geprüft	Approved Freigegeben
R04	Added second nameplate and shellside vent	02.05.2024	A.Heiss	T.Stroh	S.Monjé
R03	Issued for review. Changed shell flange ring.	23.04.2024	K.Kraft	O.Latta	S.Monjé
R02	Issued for review	19.01.2024	K.Kraft	O.Latta	S.Monjé
IWS Type Code IWS Typenschlüssel		Description Beschreibung			
RLP 400/100-36-2-2/3-SS/AL-IW		Intercooler / Aircooler			
IWS-MONJÉ HEAT EXCHANGERS		Drawing No. Zeichnungsnummer			
IWS-Monjé Heat Exchangers GmbH Wittener Straße 102 44789 Bochum Germany www.iws-monje.com		Z-704233207			
This drawing and all data contained is exclusive property of IWS-Monjé Heat Exchangers GmbH and must not be disclosed to others without written consent.					
Scale Maßstab	1 : 2,5	Format Format	A2	Page Blatt	1

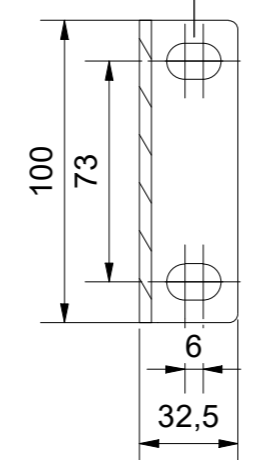
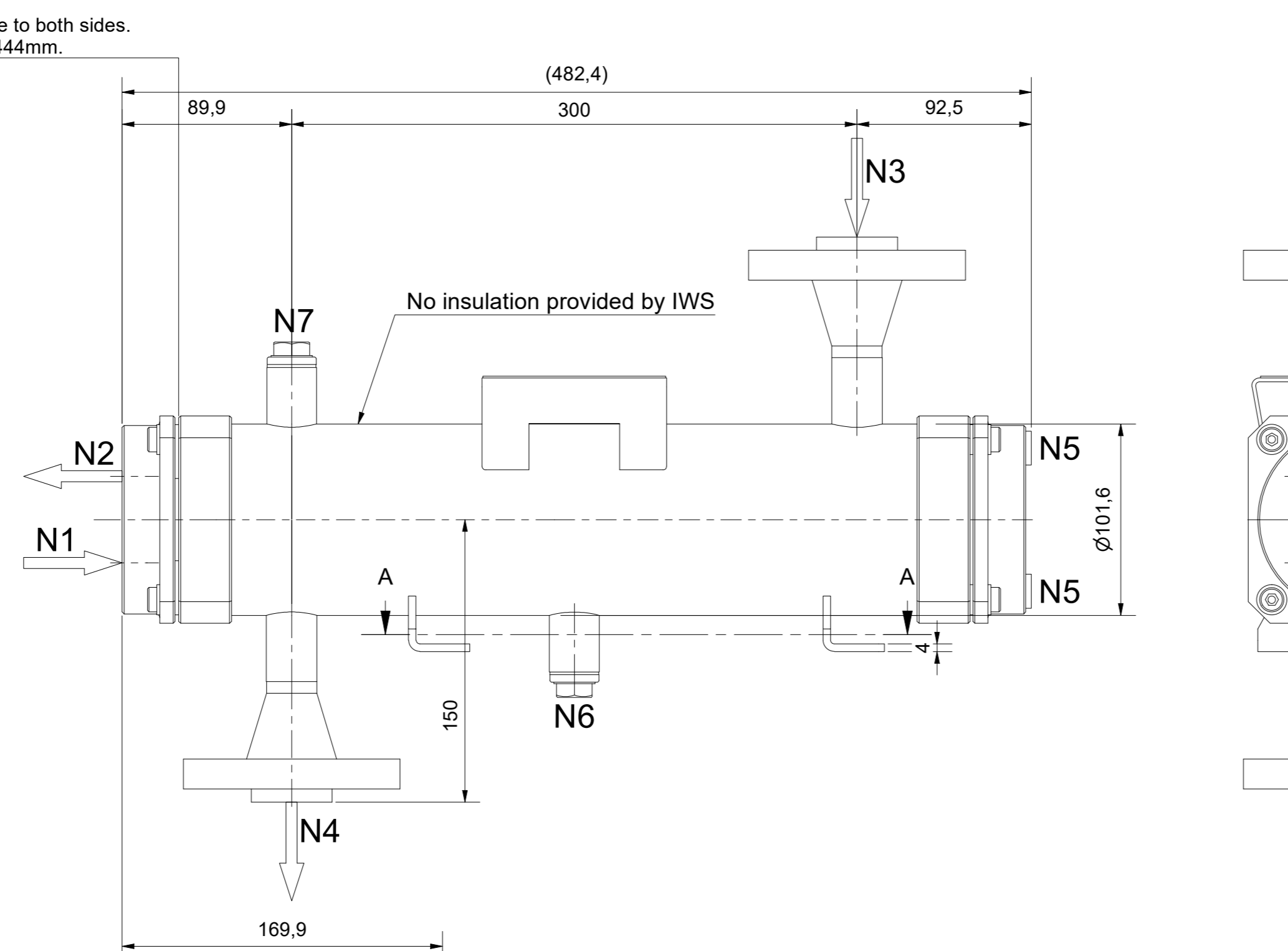

IWS-MONJÉ HEAT EXCHANGERS
Cust. No.: 320-KE-020-001
IWS No.: 704233207

Manufacturer Hersteller: 901050003

Serial No. Serien Nr.: 231135-1
Built Baujahr: 2024

	Tubeside	Shellside	
PS	-1/10	-1/39	bar(g)
V	0,8	1,7	L
TS	-10/100	-10/175	°C
PT	14,3	64,35	bar(g)
Fluidgroup	-	-	Fluidgruppe

Type / Typ: RLP 400/100-36-2-2/3-SS/AL-IW

IWS-MONJÉ HEAT EXCHANGERS
Cust. No.: 320-KE-020-002
IWS No.: 704233207

Manufacturer Hersteller: 901050003

Serial No. Serien Nr.: 231135-2
Built Baujahr: 2024

	Tubeside	Shellside	
PS	-1/10	-1/39	bar(g)
V	0,8	1,7	L
TS	-10/100	-10/175	°C
PT	14,3	64,35	bar(g)
Fluidgroup	-	-	Fluidgruppe

Type / Typ: RLP 400/100-36-2-2/3-SS/AL-IW

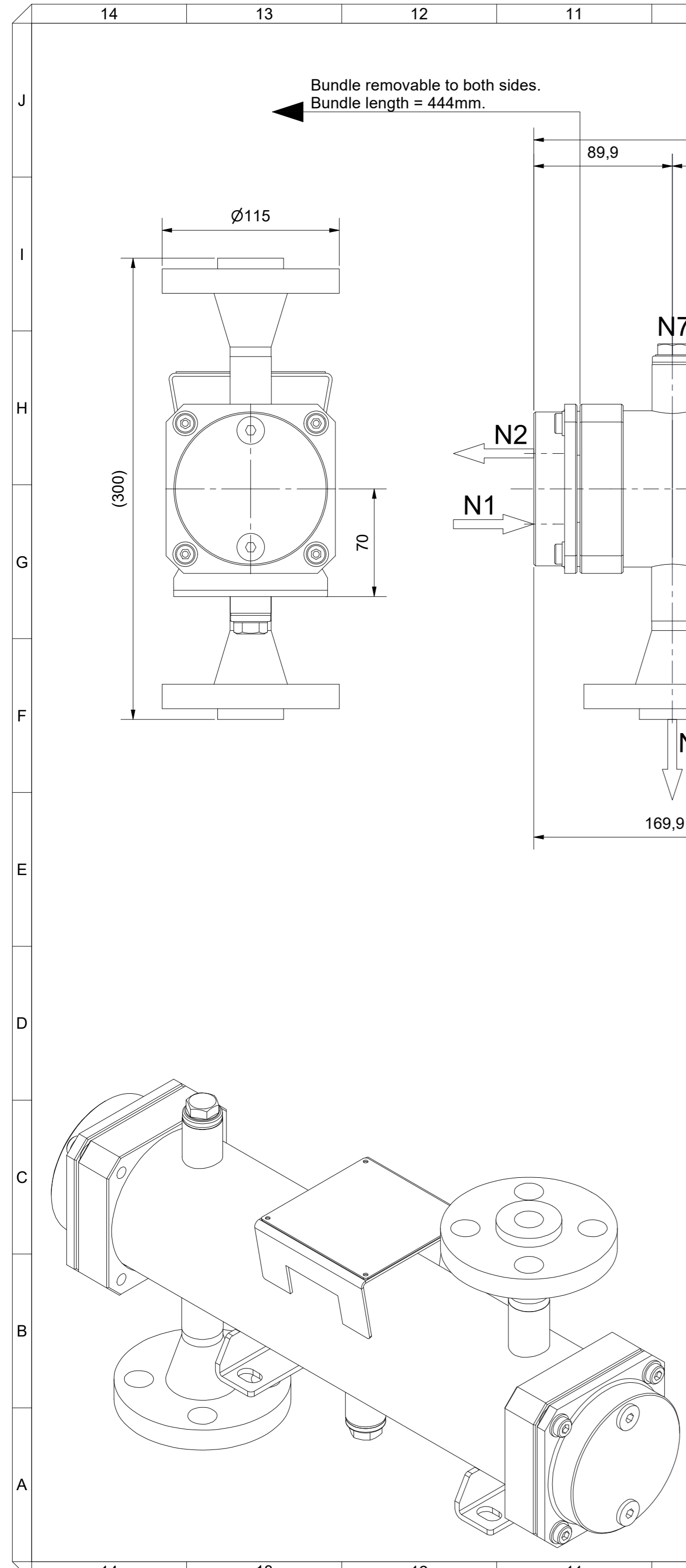

14	13	12	11	10	9	8	7	6	5	4	3	2	1						
Pos.	Qty. / Menge	Description	Bezeichnung	Material / Werkstoff	Material Standard / Werkstoff Norm	Cert. / Zgn.	Standard / Norm	Dimensions / Abmessungen	Notes / Bemerkungen	Pos.	Qty. / Menge	Description	Bezeichnung	Material / Werkstoff	Material Standard / Werkstoff Norm	Cert. / Zgn.	Standard / Norm	Dimensions / Abmessungen	Notes / Bemerkungen
1	1	Shell Assembly	Mantel Baugruppe	-	-	-	-	-	-	1.1	1	Shell	Mantel	TP316	SA-312	3.1	-	Ø101,6mm x 4,5mm x 379,8mm	-
2	1	Bundle Assembly	Bündel Baugruppe	-	-	-	-	-	-	1.2	2	Flanging	Flanschring	F316	SA-182	3.1	-	K10-2881-02	-
3	1	Inlet/Outlet Bonnet	Einlass-/Auslasskammer	304	SA-240	3.1	-	KL10-F-14	-	1.3	2	Welding Neck Flange	Vorschweißflansch	F316	SA-182	3.1	ASME B16.5	3/4" Class 600 RF	-
4	1	Return Bonnet	Umlenkammer	304	SA-240	3.1	-	KL10-F-15	-	1.4	2	Nozzle Pipe	Stutzenrohr	TP316	SA-312	3.1	-	Ø26,9mm x 3,9mm	-
5	1	Nameplate - IWS	Typenschild - IWS	304	-	-	-	t=1mm	-	1.5	2	Socket	Muffe	TP316	SA-312	3.1	-	G 1/2"	-
6	4	Fixing Plate	Fixierblech	304	SA-240	-	-	-	-	1.6	2	Plug	Stopfen	316	SA-182	3.1	-	G 1/2"	-
7	8	Bolt	Schraube	B8	SA-193	3.1	DIN 6912	M8 x 30	-	1.7	2	Sealing Ring	Dichtring	Aluminium	-	-	-	-	-
8	12	Washer	Scheibe	304	SA-240	-	DIN 125 A	D9	-	1.8	2	Foot	Fuß	304	SA-240	-	-	-	-
										1.9	1	Nameplate Holder	Typenschildhalter	304	SA-240	-	-	t=2mm	-

14	13	12	11	10	9	8	7	6	5	4	3	2	1						
Pos.	Qty. / Menge	Description	Bezeichnung	Material / Werkstoff	Material Standard / Werkstoff Norm	Cert. / Zgn.	Standard / Norm	Dimensions / Abmessungen	Notes / Bemerkungen	Pos.	Qty. / Menge	Description	Bezeichnung	Material / Werkstoff	Material Standard / Werkstoff Norm	Cert. / Zgn.	Standard / Norm	Dimensions / Abmessungen	Notes / Bemerkungen
1.1	1	Shell	Mantel	TP316	SA-312	3.1	-	-	-	1.1	1	Shell	Mantel	TP316	SA-312	3.1	-	Ø101,6mm x 4,5mm x 379,8mm	-
1.2	2	Flanging	Flanschring	F316	SA-182	3.1	-	-	-	1.2	2	Flanging	Flanschring	F316	SA-182	3.1	-	K10-2881-02	-
1.3	2	Welding Neck Flange	Vorschweißflansch	F316	SA-182	3.1	ASME B16.5	3/4" Class 600 RF	-	1.3	2	Welding Neck Flange	Vorschweißflansch	F316	SA-182	3.1	ASME B16.5	3/4" Class 600 RF	-
1.4	2	Nozzle Pipe	Stutzenrohr	TP316	SA-312	3.1	-	Ø26,9mm x 3,9mm	-	1.4	2	Nozzle Pipe	Stutzenrohr	TP316	SA-312	3.1	-	Ø26,9mm x 3,9mm	-
1.5	2	Socket	Muffe	TP316	SA-312	3.1	-	G 1/2"	-	1.5	2	Socket	Muffe	TP316	SA-312	3.1	-	G 1/2"	-
1.6	2	Plug	Stopfen	316	SA-182	3.1	-	G 1/2"	-	1.6	2	Plug	Stopfen	316	SA-182	3.1	-	G 1/2"	-
1.7	2	Sealing Ring	Dichtring	Aluminium	-	-	-	-	-	1.7	2	Sealing Ring	Dichtring	Aluminium	-	-	-	-	-
1.8	2	Foot	Fuß	304	SA-240	-	-	-	-	1.8	2	Foot	Fuß	304	SA-240	-	-	-	-
1.9	1	Nameplate Holder	Typenschildhalter	304	SA-240	-	-	t=2mm	-	1.9	1	Nameplate Holder	Typenschildhalter	304	SA-240	-	-	t=2mm	-

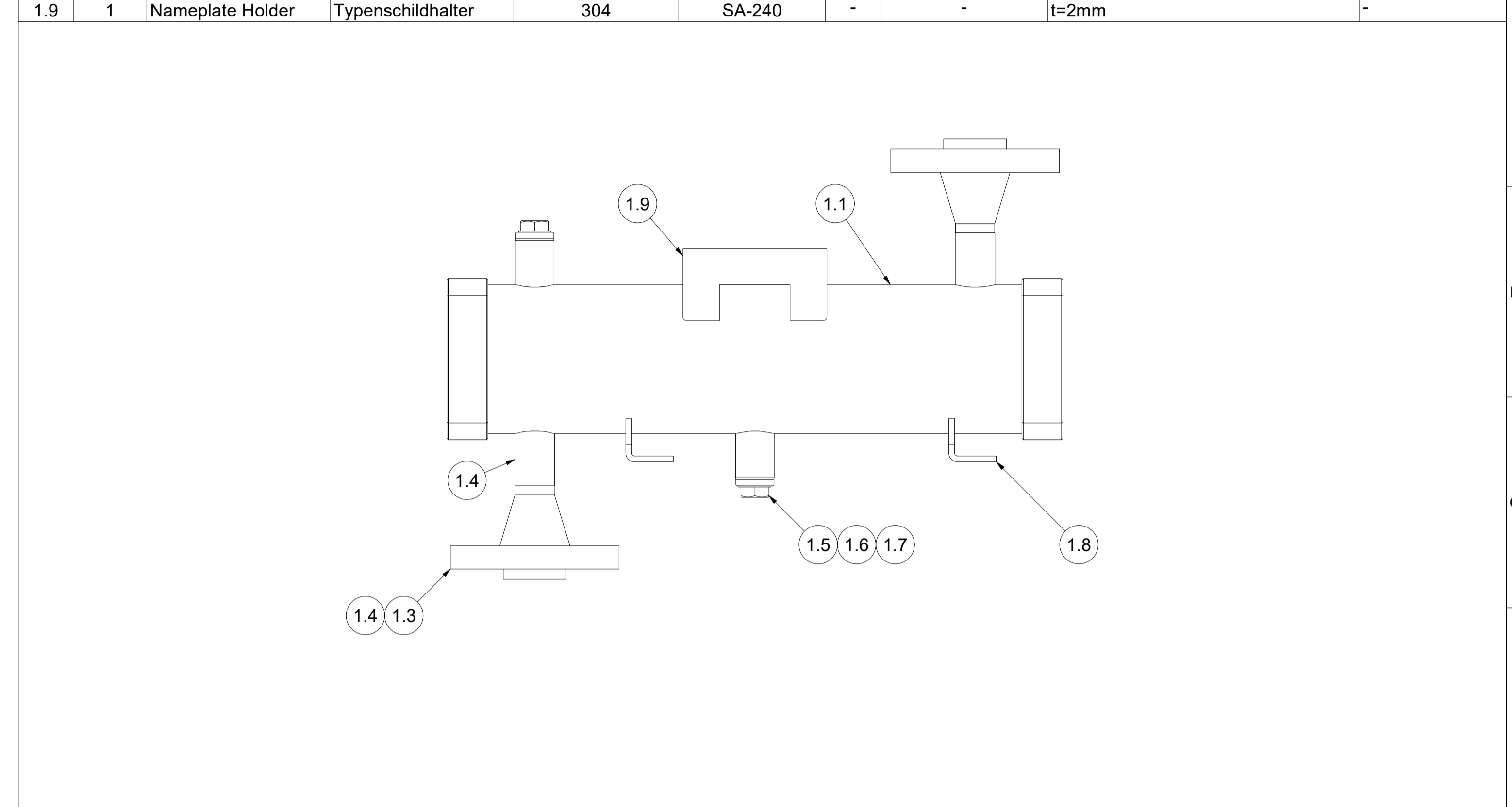
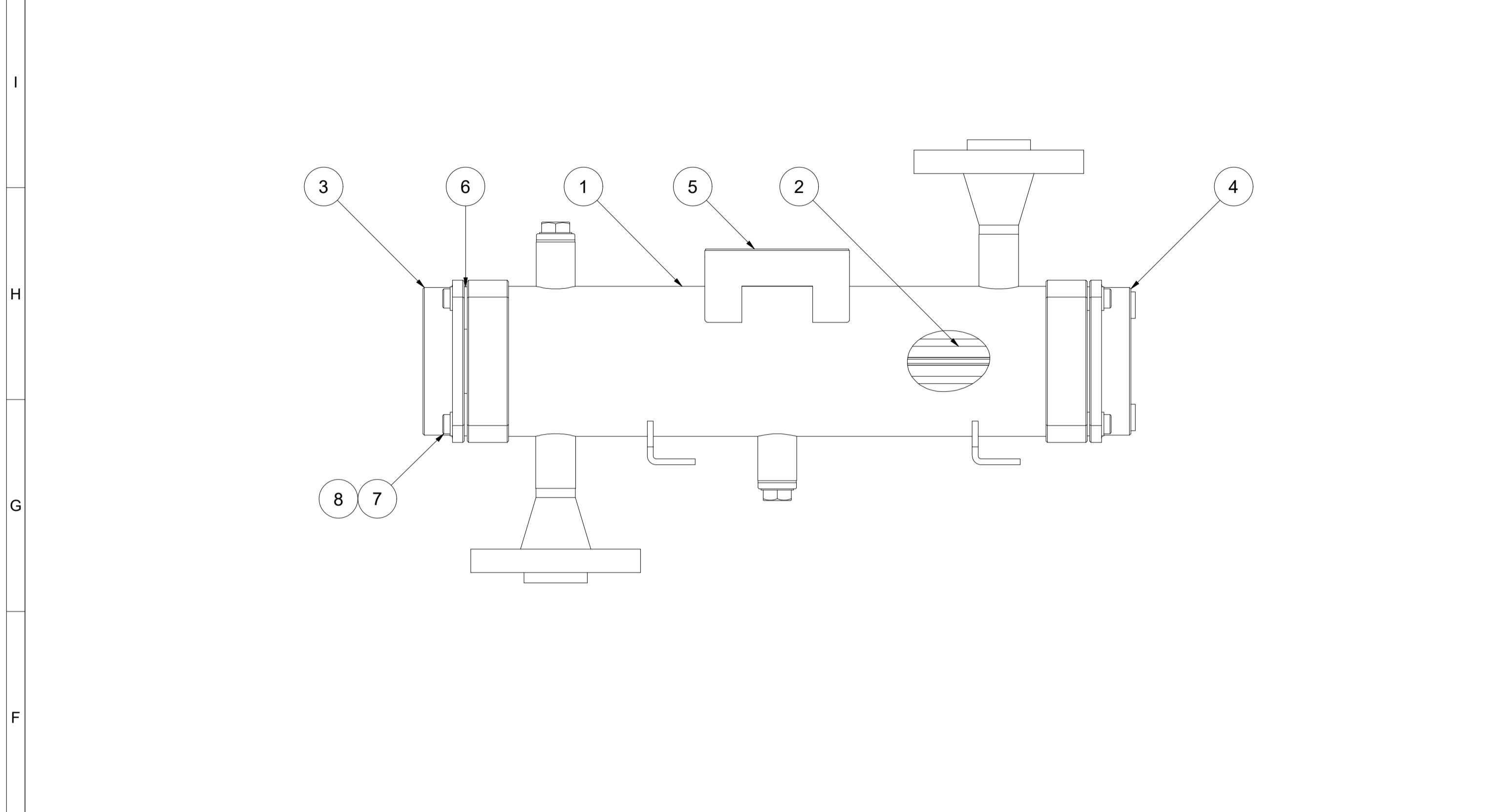

Pos.	Qty. / Menge	Description	Bezeichnung	Material / Werkstoff	Material Standard / Werkstoff Norm	Cert. / Zgn.	Standard / Norm	Dimensions / Abmessungen	Notes / Bemerkungen
2.1	2	Tubesheet	Rohrplatte	316L	SA-182	3.1	-	Ø91,8mm x 22mm	-
2.2	36	Tube	Rohr	TP316L	SA-312	3.1	-	Ø8mm x 0,5mm	-
2.3	2	Baffle	Umlenkblech	Aluminium	-	-	-	t=4,5mm	-
2.4	1	Fin	Rippe	Aluminium	-	-	-	-	-
2.5	1	Divider Gasket	Trennsteg	PE-1000	-	-	-	-	-
2.6	4	O-Ring	O-Ring	Viton	-	-	-	-	-

Pos.	Qty. / Menge	Description	Bezeichnung	Material / Werkstoff	Material Standard / Werkstoff Norm	Cert. / Zgn.	Standard / Norm	Dimensions / Abmessungen	Notes / Bemerkungen
2.1	2	Tubesheet	Rohrplatte	316L	SA-182	3.1	-	Ø91,8mm x 22mm	-
2.2	36	Tube	Rohr	TP316L	SA-312	3.1	-	Ø8mm x 0,5mm	-
2.3	2	Baffle	Umlenkblech	Aluminium	-	-	-	t=4,5mm	-
2.4	1	Fin	Rippe	Aluminium	-	-	-	-	-
2.5	1	Divider Gasket	Trennsteg	PE-1000	-	-	-	-	-
2.6	4	O-Ring	O-Ring	Viton	-	-	-	-	-

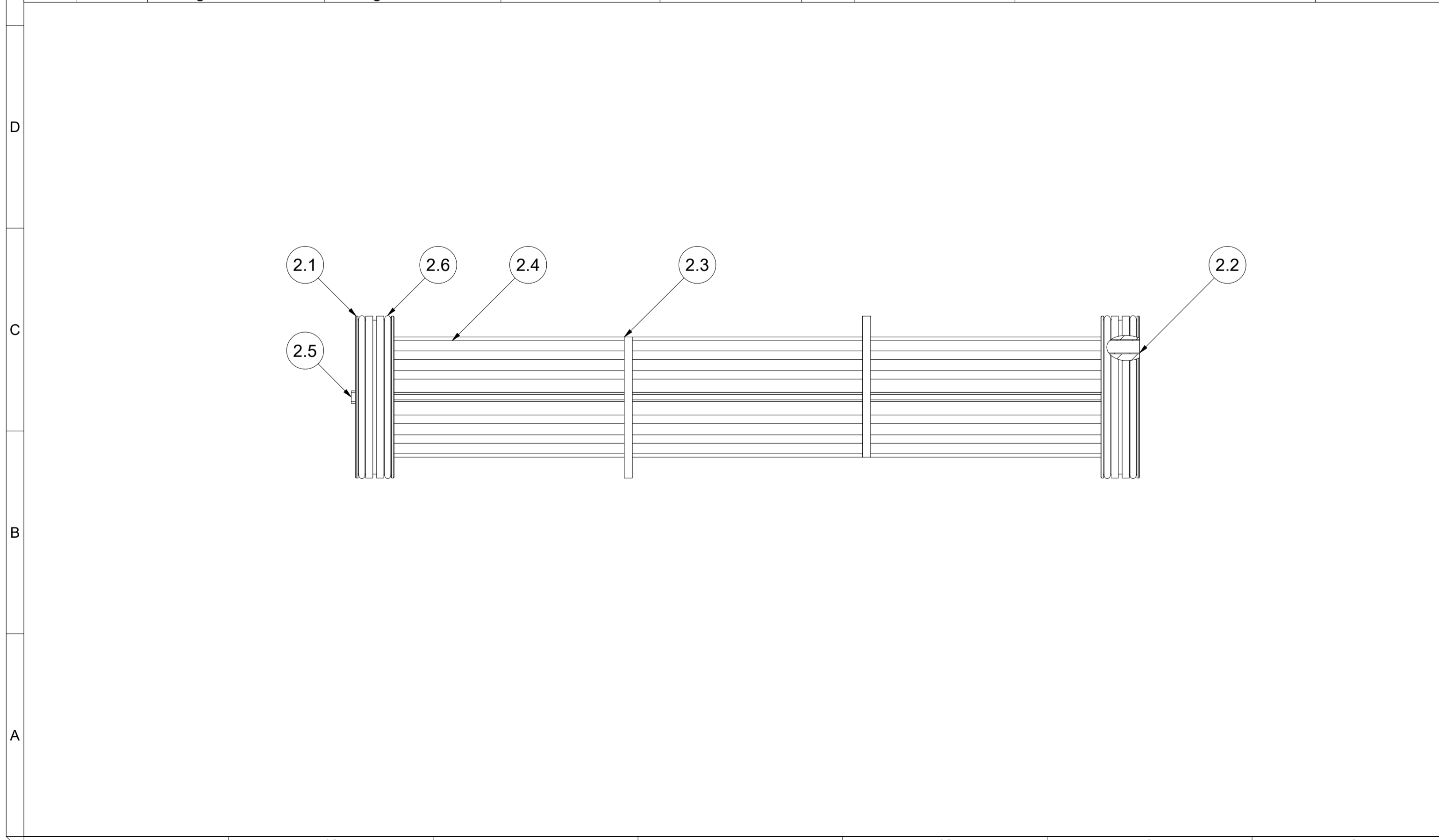

Revisions					
Rev.	Reason for Issue	Date	Drawn	Checked	Approved
Rev.	Grund der Ausgabe	Datum	Geszeichnet	Geprüft	Freigegeben
R04	Added second nameplate and shellside vent	02.05.2024	A.Heiss	T.Strohm	S.Monje
R03	Issued for review. Changed shell flange ring.	23.04.2024	K.Kraft	O.Latta	S.Monje
R02	Issued for review	19.01.2024	K.Kraft	O.Latta	S.Monje

IWS Type Code IWS Typenschlüssel	RPL 400/100-36-2-2/3-SS/AL-IW	Description Beschreibung	Intercooler / Aircooler
		Drawing No. Zeichnungsnummer	Z-704233207
<small>Tolerances in acc. to EN ISO 13920-DH and ASME VIII Div. 1 UW-33, UW-35, UG-79, UG-80, UG-81</small>			
<small>This drawing and all data contained is exclusive property of IWS-Monje Heat Exchangers GmbH and must not be disclosed to others without written consent.</small>		Scale Maßstab	1 : 2,5
		Format	A1
		Page	2