





OWNER 	BUSHEHR PETROCHEMICAL COMPANY MEG PLANT							EPC CONTRACTOR:  Chagalesh-Enerchimi-Steam Joint Venture BUPC-MEG PLANT PROJECT	
	UCP general arrangement drawing & terminal detail for reciprocating compressor								
MC :  شرکت سفت و سوی توسعه ایرانیان	Project	Area	Phase	Unit	Dis.	Doc.	Seq.	Contract No : 52-98/445	
Owner Document Number: 17811-07	BU	20	VD	303	IN	DWG	0039	Rev.:	Page
								00	1 of 13



Prerequisite document such as JB wiring diagram shall be issued.

This document is checked only for compressor 7080. New document should be generated for compressor 1002.

UCP general arrangement drawing & terminal detail for reciprocating compressor

		BUSHEHR PETROCHEMICAL COMPANY MEG PLANT	
Document Review			
Issue Purpose:	FA		
Result Code: AP,AN,CM,RE,NC	CM		
Next Status : IFC,IFA,IFI,AFC,AB	IFA		
Responsible Department	MECHANICAL		
Commented Date	May.05.2021		
Approval or review hereunder shall not be construed to relieve Vendor / Subcontractor of his responsibilities and liability under the contract.			

00	24/11/2020	For approval	HT	RB	KP	
Rev.	Date	Purpose of Issue	Prepared	Checked	Approved	AC Code
						Class: 1 Phase: p

OWNER  شرکت پتروشیمی بوته‌ر	BUSHEHR PETROCHEMICAL COMPANY MEG PLANT						EPC CONTRACTOR: 		
	UCP general arrangement drawing & terminal detail for reciprocating compressor								
MC :  شرکت سفت و سوی توسعه ایرانیان	Project	Area	Phase	Unit	Dis.	Doc.	Seq.	Contract No : 52-98/445	
Owner Document Number: 17811-07	BU	20	VD	303	IN	DWG	0039	Rev.:	Page
								00	2 of 13

TABULATION OF REVISED PAGES

Page	D00	D01	D02	D03	D04
1.	X				
2.	X				
3.	X				
4.	X				
5.	X				
6.	X				
7.	X				
8.	X				
9.	X				
10.	X				
11.	X				
12.	X				
13.	X				
14.					
15.					
16.					
17.					
18.					
19.					
20.					
21.					
22.					
23.					
24.					
25.					
26.					
27.					
28.					
29.					
30.					
31.					
32.					
33.					
34.					

Page	D00	D01	D02	D03	D04
35.					
36.					
37.					
38.					
39.					
40.					
41.					
42.					
43.					
44.					
45.					
46.					
47.					
48.					
49.					
50.					
51.					
52.					
53.					
54.					
55.					
56.					
57.					
58.					
59.					
60.					
61.					
62.					
63.					
64.					
65.					
66.					
67.					

JB_ANLG_A

FRONT SIDE (OUTSIDE) VIEW

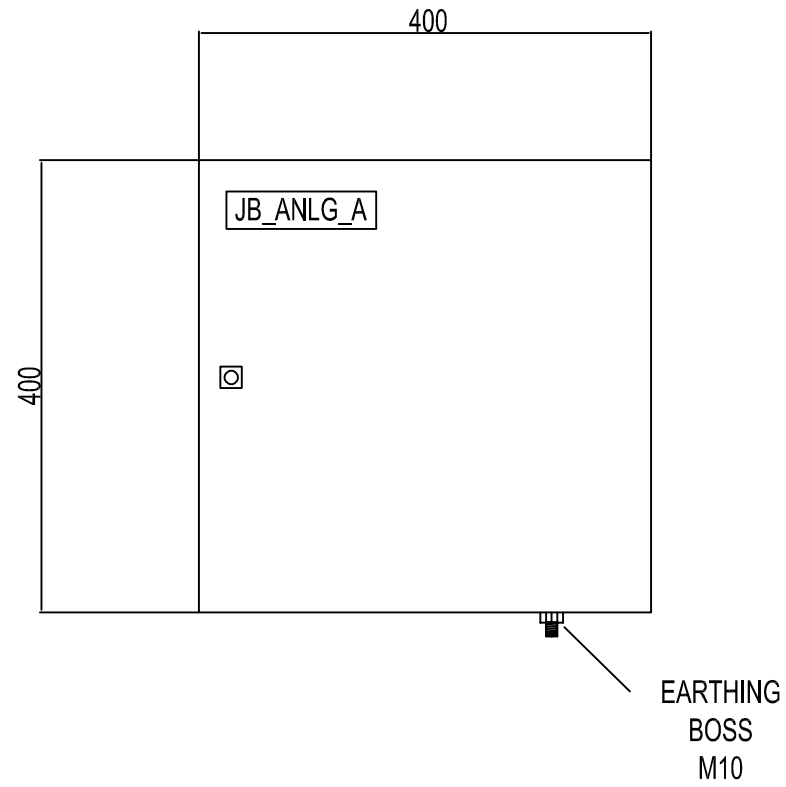

FRONT SIDE (INSIDE) VIEW

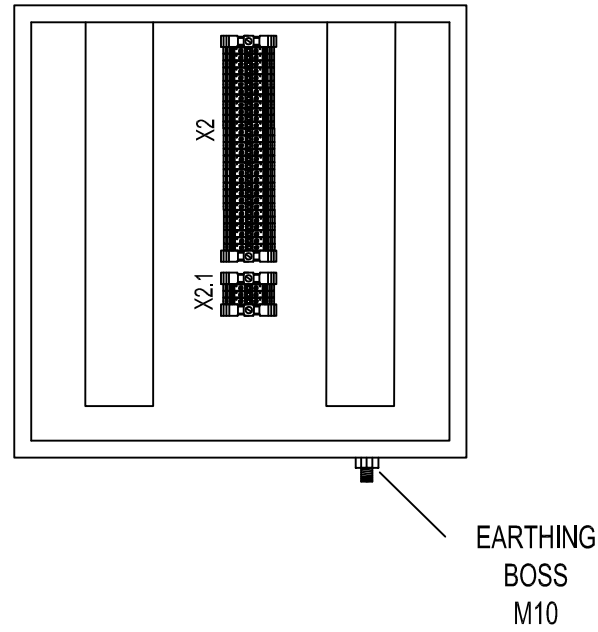

SIDE (OUTSIDE) VIEW

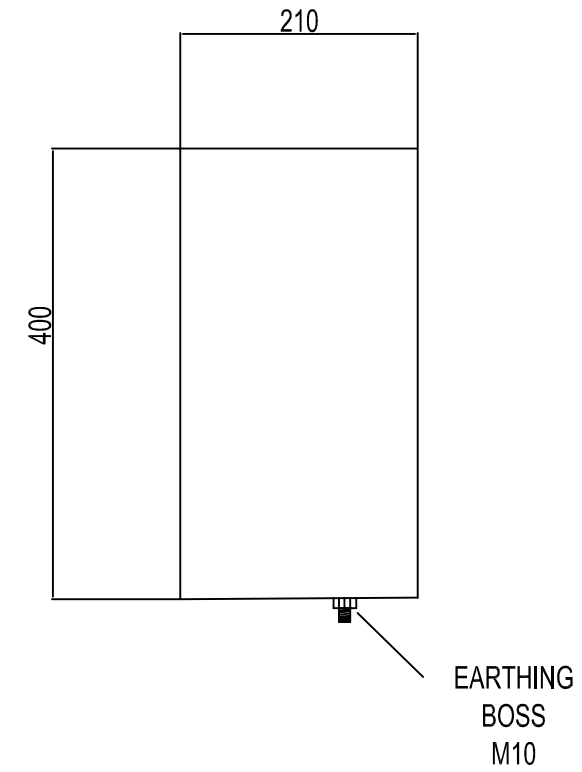

BOTTOM VIEW

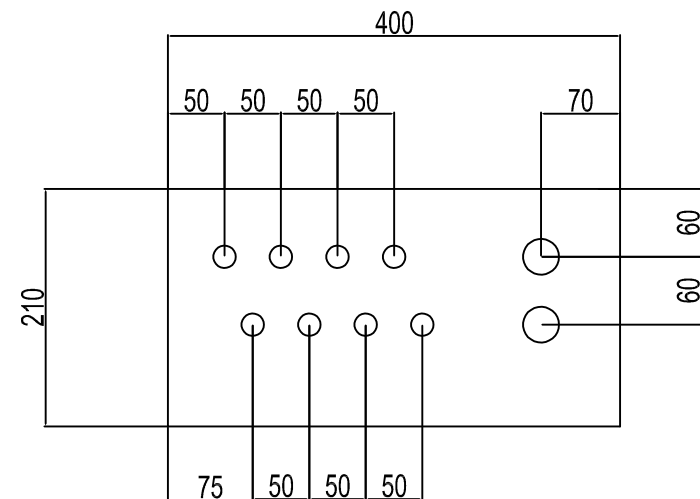

GLAND ENTRY DETAILS

M20: 8x
M32: 2x

to be in accordance with cable sch

GENERAL NOTES

1. Panel material: SS316
2. Ingress protection: IP-65
3. Panel dimensions: 400x400x210 mm
4. Area classification: Eex 'e'
5. All spare holes are plugged with certified plugs

REFERENCE DRAWINGS	DWG.No.
xxxxxxx	xxxxxxx

00	24/11/20	For approval	HT	RB	RB	-
REV.	DATE	PURPOSE OF ISSUE (P.O.I.)	PREP.	CHKD.	APPR.	AC.
OWNER:	MC:	CONTRACTOR:				
PROJECT: BUSHEHR PETROCHEMICAL COMPANY MEG PLANT						
DRAWING TITLE: 17811-07 UCP GENERAL ARRANGEMENT DRAWING & TERMINAL DETAILS						
CONTRACT NO.	SCALE	SIZE	CLASS	PHASE		
S2-88/445	XX	A0	-	-		
DOCUMENT NO.	PROJECT	AREA	PHASE	MRQ No.	DIS.	DOC. SEQ.
OWNER DOC. NO.:	-	-	-	-	-	-
						SHEET REV. NO. - OF -

THIS DOCUMENT IS THE PROPERTY OF AIRPACK. IT IS TO BE USED ONLY FOR THE PROJECT AND NOT TO BE REPRODUCED OR COPIED IN ANY FORM OR BY ANY MEANS WITHOUT THE WRITTEN PERMISSION OF AIRPACK.

JB-DIG-B

FRONT SIDE (OUTSIDE) VIEW

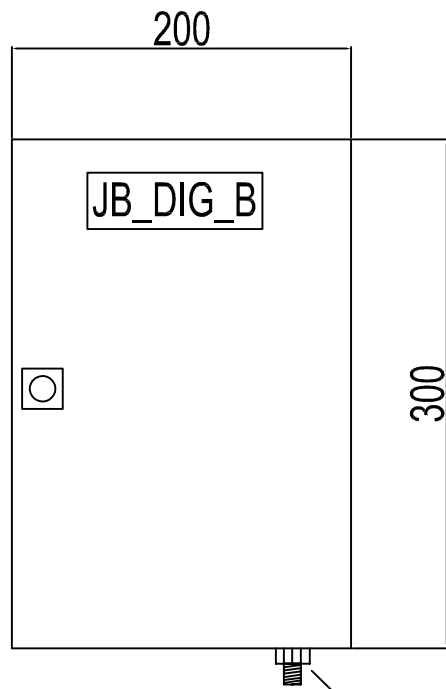

FRONT SIDE (INSIDE) VIEW

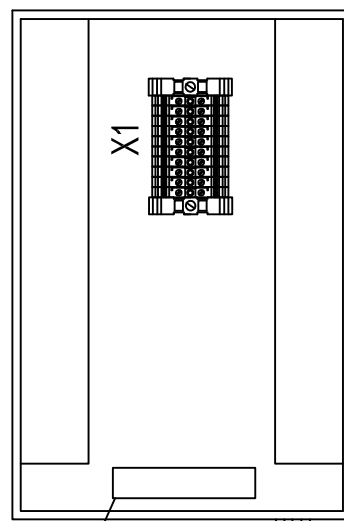

SIDE (OUTSIDE) VIEW

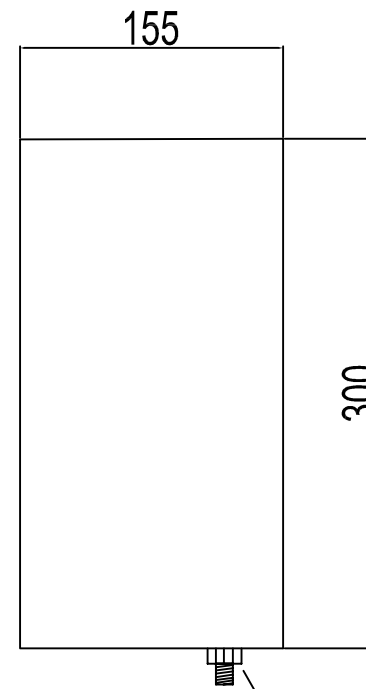

BOTTOM VIEW

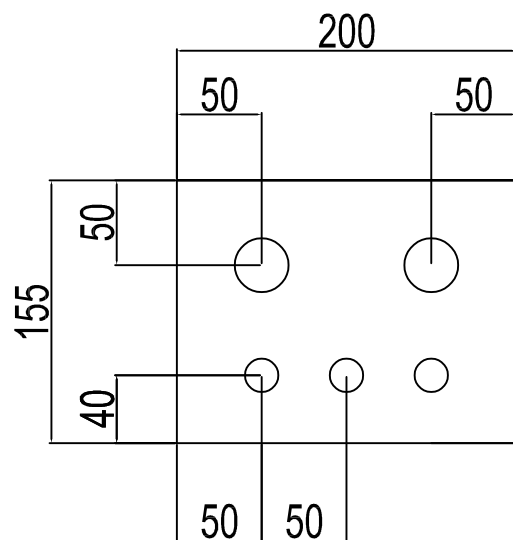

EARTHING BOSS M10

PE Bar

EARTHING BOSS M10

EARTHING BOSS M10

GLAND ENTRY DETAILS

M20: 3x
M25: 1x

GENERAL NOTES

1. Panel material: SS316
2. Ingress protection: IP-65
3. Panel dimensions: 200x300x155 mm
4. Area classification: Eex 'e'
5. All spare holes are plugged with certified plugs

REFERENCE DRAWINGS
xxxxxxx

DWG.No.
xxxxxxx

00	24/11/20	For approval	HT	RB	RB	-
REV.	DATE	PURPOSE OF ISSUE (P.O.I)	PREP.	CHKD.	APPR.	AC.

OWNER:

MC:

CONTRACTOR:

PROJECT: BUSHEHR PETROCHEMICAL COMPANY
MEG PLANT

DRAWING TITLE:
17811-07
UCP GENERAL ARRANGEMENT DRAWING & TERMINAL DETAILS

CONTRACT NO.	SCALE	SIZE	CLASS	PHASE					
S2-28/445	XX	A0	-	-					
DOCUMENT NO.	PROJECT	AREA	PHASE	MRQ No.	DIS.	DOC.	SEQ.	SHEET	REV. NO.
-	-	-	-	-	-	-	-	-	-
OWNER DOC. NO.:	-	-	-	-	-	-	-	-	-

REPRODUCTION OF THIS DOCUMENT IS PROHIBITED WITHOUT THE WRITTEN PERMISSION OF AIRPACK

JB_ANLG_B

FRONT SIDE (OUTSIDE) VIEW

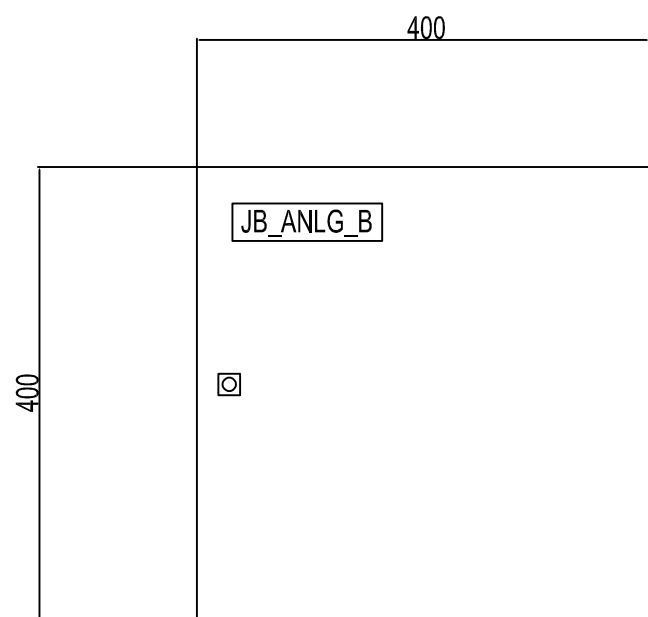

EARTHING BOSS M10

FRONT SIDE (INSIDE) VIEW

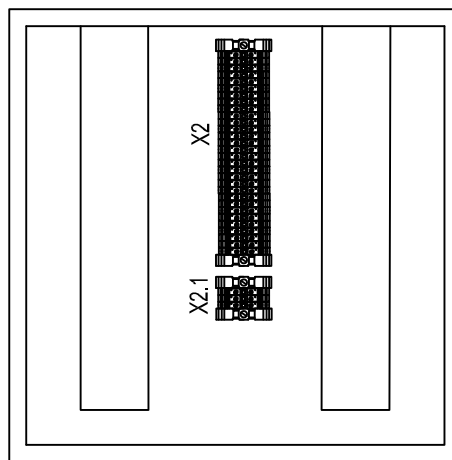

EARTHING BOSS M10

SIDE (OUTSIDE) VIEW

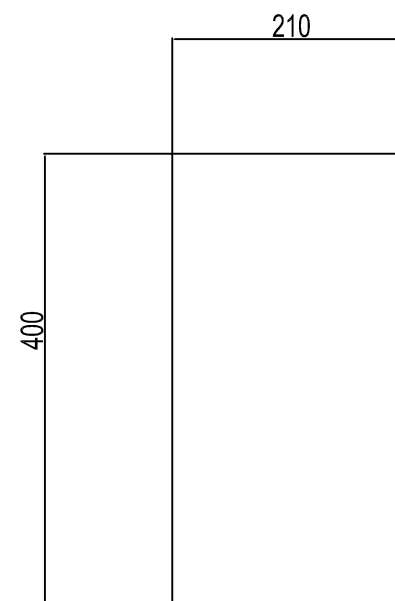

EARTHING BOSS M10

BOTTOM VIEW

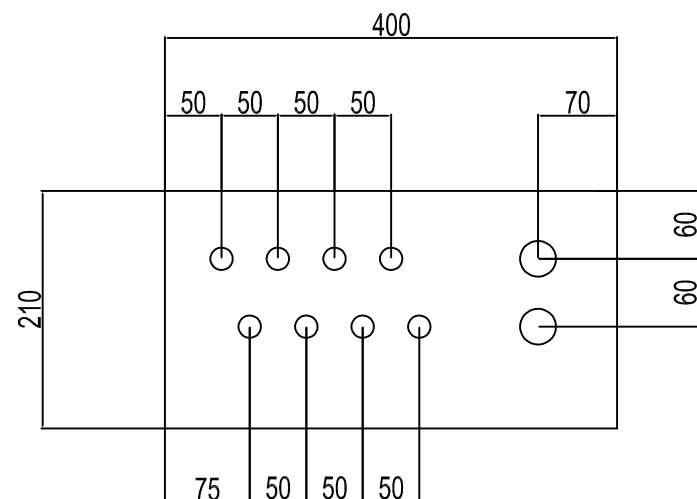

GLAND ENTRY DETAILS

M20: 8x
M32: 2x

GENERAL NOTES

1. Panel material: SS316
2. Ingress protection: IP-65
3. Panel dimensions: 400x400x210 mm
4. Area classification: Eex 'e'
5. All spare holes are plugged with certified plugs

REFERENCE DRAWINGS	DWG.No.
xxxxxxx	xxxxxxx

00	24/11/20	For approval	HT	RB	RB	-
REV.	DATE	PURPOSE OF ISSUE (P.O.I)	PREP.	CHKD.	APPR.	AC.

OWNER:

MC:

CONTRACTOR:

PROJECT: BUSHEHR PETROCHEMICAL COMPANY
MEG PLANT

DRAWING TITLE:
17811-07
UCP GENERAL ARRANGEMENT DRAWING & TERMINAL DETAILS

CONTRACT NO.	SCALE	SIZE	CLASS	PHASE					
S2-88/445	XX	A0	-	-					
DOCUMENT NO.	PROJECT	AREA	PHASE	MRQ No.	DIS.	DOC.	SEQ.	SHEET	REV. NO.
OWNER DOC. NO.:	-	-	-	-	-	-	-	-	OF -

REPRODUCTION OR TRANSMISSION OF THIS DOCUMENT IN WHOLE OR IN PART WITHOUT THE WRITTEN CONSENT OF B.P.C.

LCP_B

FRONT SIDE (OUTSIDE) VIEW

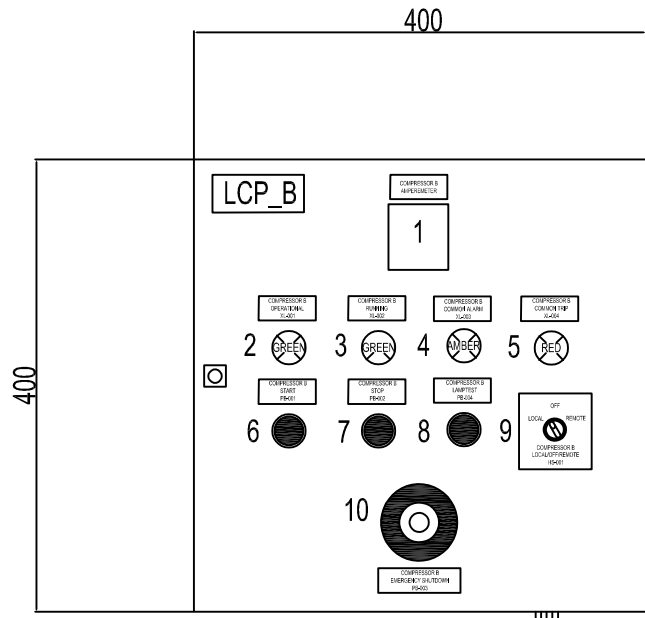

EARTHING BOSS M10

FRONT SIDE (INSIDE) VIEW

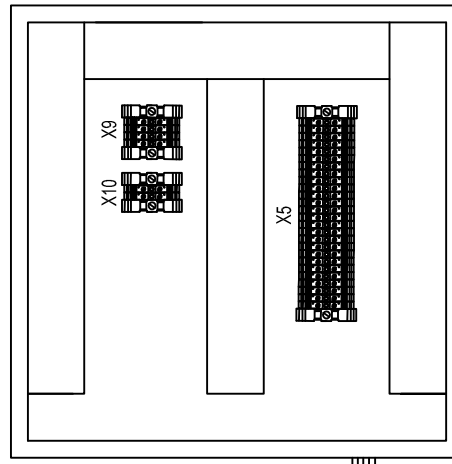

EARTHING BOSS M10

SIDE (OUTSIDE) VIEW

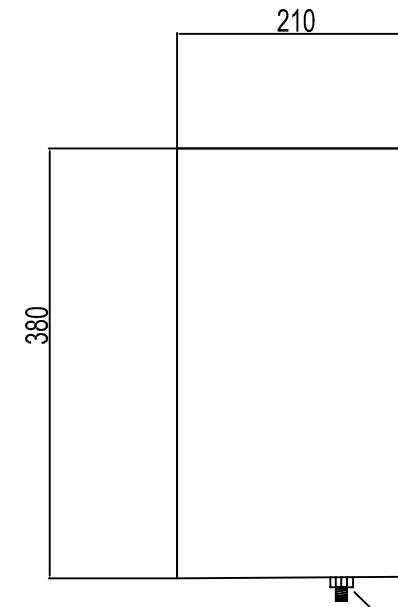

EARTHING BOSS M10

BOTTOM VIEW

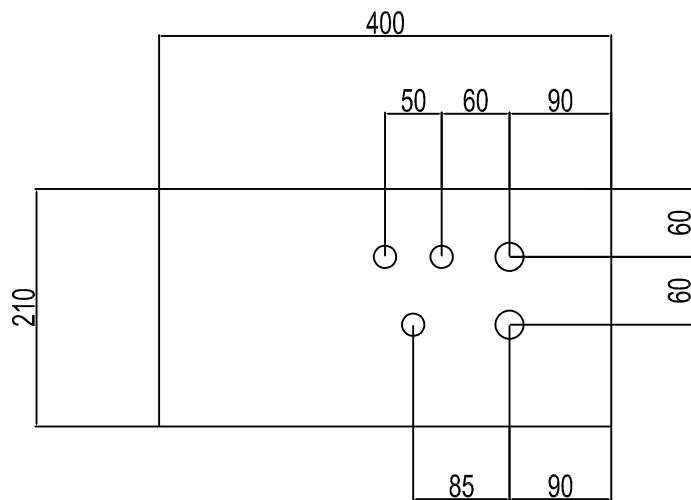

GLAND ENTRY DETAILS

M20: 3x
M25: 2x

GENERAL NOTES

1. Panel material: SS316
2. Ingress protection: IP-65
3. Panel dimensions: 400x400x210 mm
4. Area classification: Eex 'e'
5. All spare holes are plugged with certified plugs

REFERENCE DRAWINGS	DWG.No.
xxxxxxx	xxxxxxx

00	24/11/20	For approval	HT	RB	RB	-
REV.	DATE	PURPOSE OF ISSUE (P.O.I)	PREP.	CHKD.	APPR.	AC.
OWNER:	MC:	CONTRACTOR:				
PROJECT: BUSHEHR PETROCHEMICAL COMPANY MEG PLANT						
DRAWING TITLE: 17811-07 UCP GENERAL ARRANGEMENT DRAWING & TERMINAL DETAILS						
CONTRACT NO.	SCALE	SIZE	CLASS	PHASE		
S2-88/445	XX	A0	-	-		
DOCUMENT NO.	PROJECT	AREA	PHASE	MRQ No.	DIS.	DOC. SEQ.
OWNER DOC. NO.:	-	-	-	-	-	-
REV. NO.	-	-	-	-	-	-

REPRODUCTION OR TRANSMISSION OF THIS DOCUMENT IN WHOLE OR IN PART WITHOUT THE WRITTEN CONSENT OF AIRPACK IS PROHIBITED.