







OWNER:  شرکت سست و سویی گیس ایر ایران (سهامی خاص)	BUSHEHR PETROCHEMICAL COMPANY MEG PLANT							EPC CONTRACTOR:  Chagalesh-Enerchimi-Steam Joint Venture BUPC-MEG PLANT PROJECT	
	<b>COMPRESSOR MOTOR OUTLINE          DRAWING &amp; TERMINAL BOX WIRING          DIAGRAM FOR NITROGEN GAS          BOOSTER</b>							 Netherlands	
MC :  شرکت سست و سویی گیس ایر ایران (سهامی خاص)	Project	Area	Phase	Unit	Dis.	Doc.	Seq.	Contract No: 52-98/445	
Owner Document Number: 17811-39B	BU	20	VD	303	EL	DWG	0101	Rev.:	Page
								00	1 of 5

**Conflict!**  
**Conflict shall be clarified.**

## COMPRESSOR MOTOR OUTLINE DRAWING & TERMINAL BOX WIRING DIAGRAM FOR EMERGENCY INSTRUMENT AIR COMPRESSOR

 شرکت سست و سویی گیس ایر ایران (سهامی خاص)	 Chagalesh-Enerchimi-Steam Joint Venture BUPC-MEG PLANT PROJECT	BUSHEHR PETROCHEMICAL COMPANY MEG PLANT
<b>Document Review</b>		
Issue Purpose:	FA	
Result Code: AP,AN,CM,RE,NC	CM	
Next Status : IFC,IFA,IFI,AFC,AB	IFA	
Responsible Department	MECHANICAL	
Commented Date	JAN/1/2021	
<b>Approval or review hereunder shall not be construed to relieve Vendor /          Subcontractor of his responsibilities and liability under the contract.</b>		

00	08/12/2020	For approval	KP	LdM	JR	
Rev.	Date	Purpose of Issue	Prepared	Checked	Approved	AC Code
					Class: 1	Phase: P



A

B

C

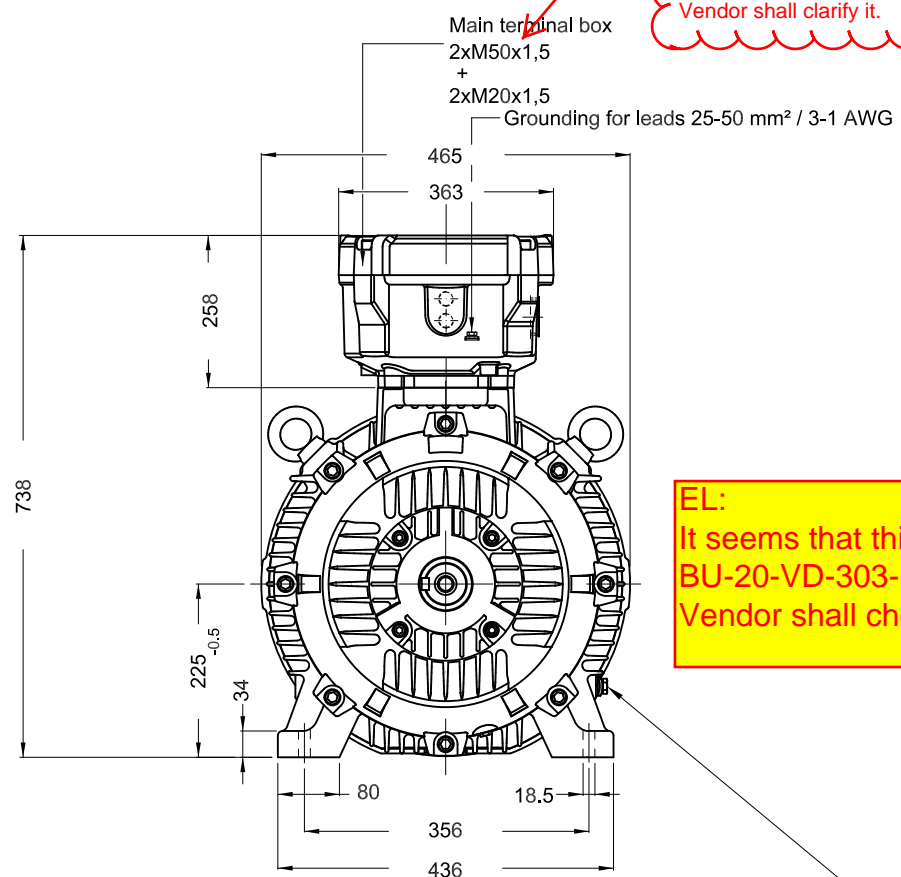

EL:  
According to "DATA SHEET FOR Emergency Instrument Air Compressor":  
Power Cable Number and Size: 4 x 6 mm<sup>2</sup>  
Power Cable Gland and Entries: 1 x M25  
Vendor shall clarify it.

EL:  
Add Compressor Tag:  
Emergency Instrument Air Compressor 20-C-7080-M

EL:  
It seems that this page is related to below document:  
BU-20-VD-303-EL-DWG-0053  
Vendor shall check it again.

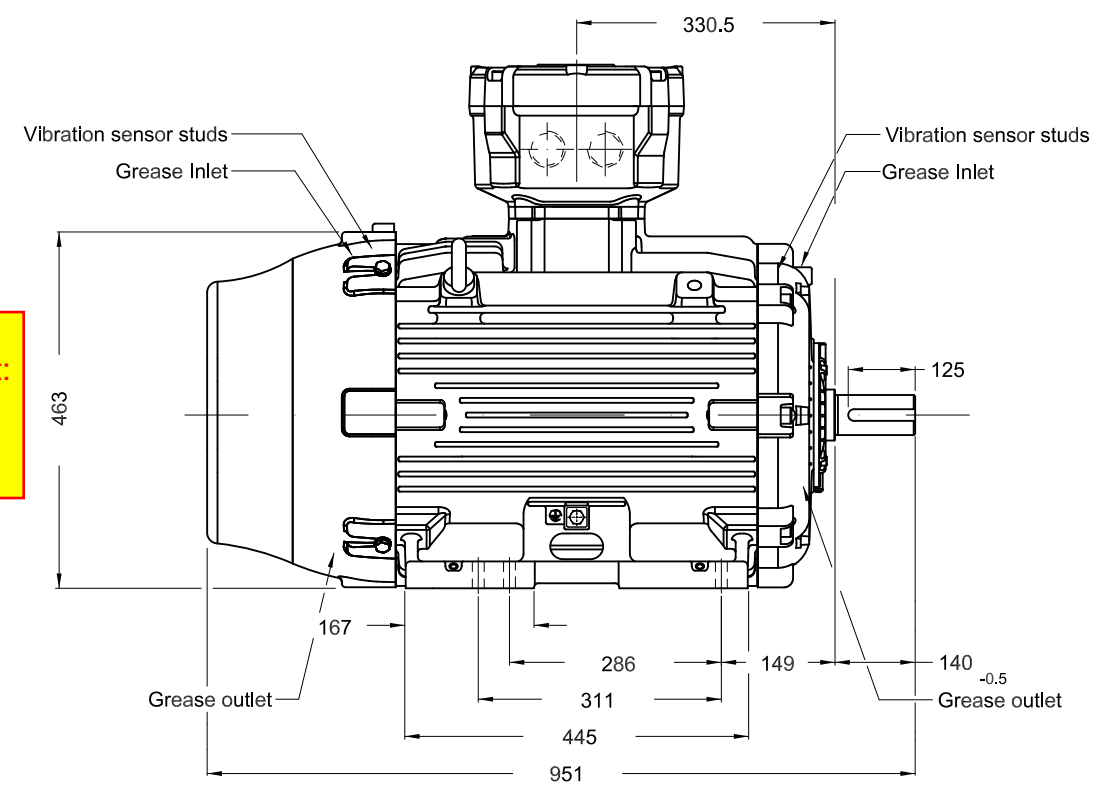

Grounding for leads 25-50 mm<sup>2</sup> / 3-1 AWG

D

EL:  
Earth stud details shall be matched with attached DETAIL "A".  
Vendor shall confirm it.

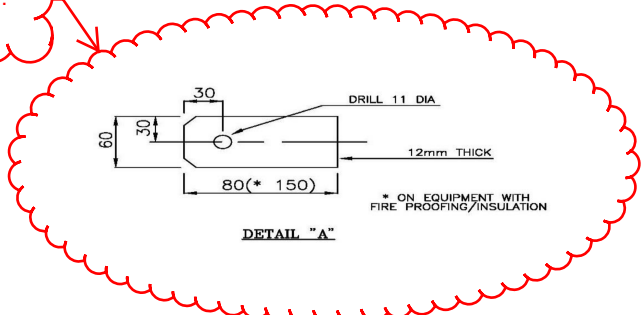

EL:  
According to "ELECTRICAL LOAD LIST FOR EMERGENCY INSTRUMENT AIR COMPRESSOR":  
Main Compressor Motor 20-C-7080-M 15KW

45 kW 04 Poles 50 Hz

E

- Tropicalized internal painting
- DE roller bearing
- Shaft locking device
- Shaft material - AISI/SAE 4140
- SPM studs
- Color RAL 5010
- Painting plan 205P
- Mounting B3T

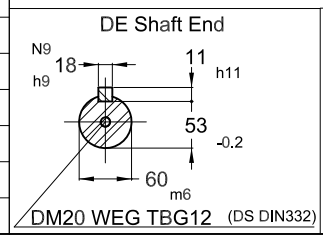

EL:  
According to "DATA SHEET FOR Emergency Instrument Air Compressor":  
Ex d IIB T4



MODIFICATIONS		EXECUTED	CHECKED	RELEASED	DATE	VER
EXECUTED	PIRWUSER					
CHECKED						
RELEASED						
REL DT.						

THREE PH. MOTOR W22Xdb IE4  
FRAME 225S/M IP56 TEFC

WMO Jaragua do Sul Product Engineering SHEET 1 / 1

EL:  
Correct it



Dimensions in mm

XME A3

Dimensional drawing subject to change. We reserve the right to change constructional details.  
 \* Detail out of scale.

EL:  
 Refer to comments on previous page.

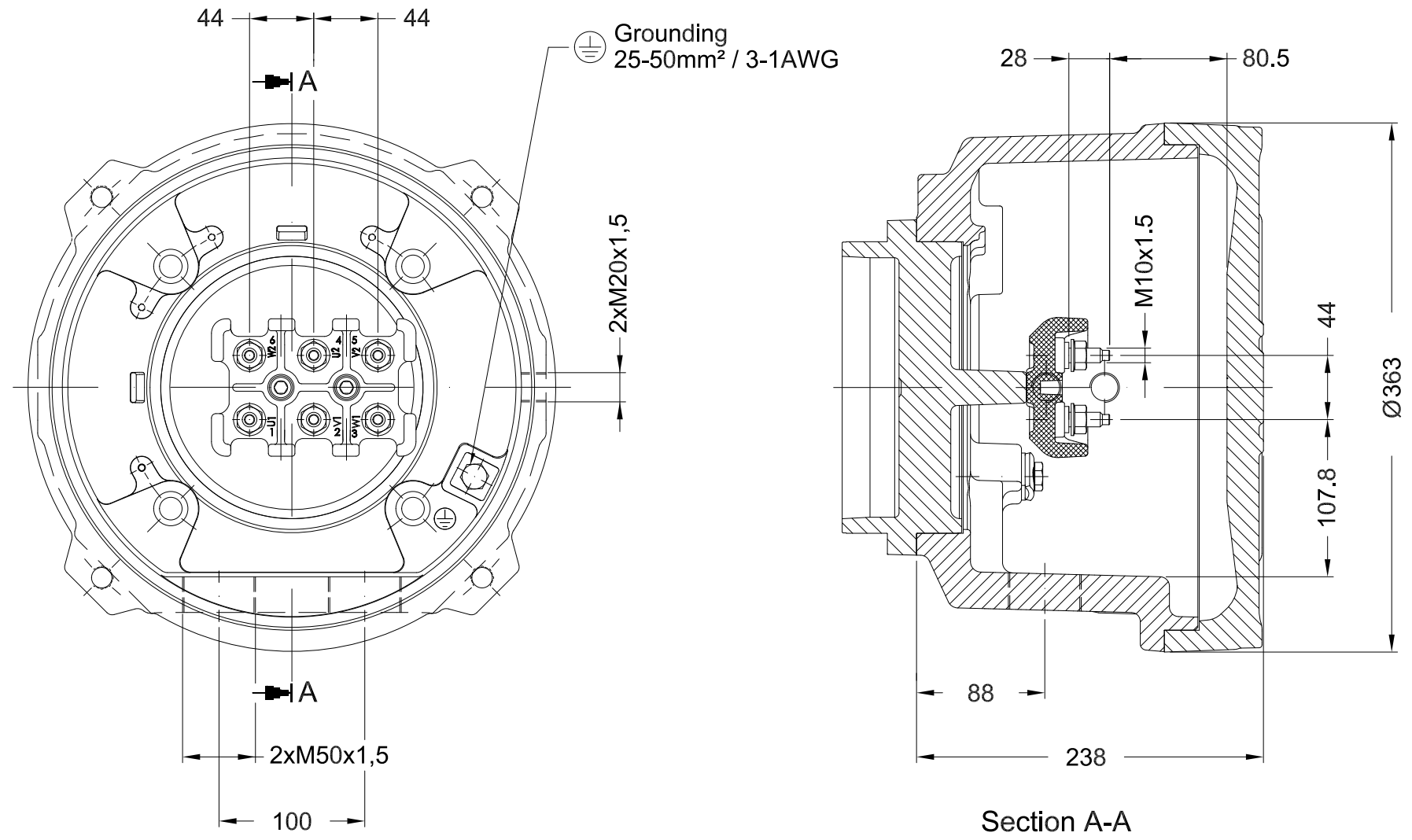

A  
 B  
 C  
 D  
 E

				ESC	1:4			
ECM	LOC	SUMMARY OF MODIFICATIONS		EXECUTED	CHECKED	RELEASED	DATE	VER
EXECUTED	YDAMHUIS	MAIN TERMINAL BOX						
CHECKED		FRAME 225S/M						
RELEASED								
REL DT.								
				<b>PREVIEW</b>				
				WCD				
				SHEET		01 / 03		

THIS IS AN UPDATED REVISION, THE PREVIOUS ONE MUST BE DISREGARDED.

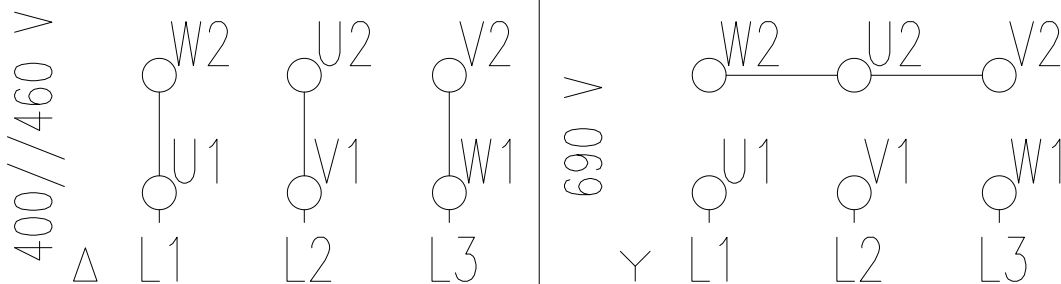

A

B

C

D

E

		ORIGINAL ISSUE		JESSICA	PATRICIA	CASTELLA	30.10.2018	00
ECM ECM	LOC LOC	RESUMO MODIFICAÇÃO SUMMARY OF MODIFICATIONS		EXECUTADO EXECUTED	VERIFICADO CHECKED	LIBERADO RELEASED	DATA DATE	VER VER
EXEC. /EXECUTED	JESSICA		LOW VOLTAGE - CONNECTION DIAGRAM		400/690//460-6			
VERIF. /CHECKED	PATRICIA		400/690//460V		IEC   00			
LIBER. /RELEASED	CASTELLA		MOTOR WITH 06 CABLES					
DATA LB /REL DT	30.10.2018	WMO	JARAGUÁ DO SUL	ADMINISTRAÇÃO DE VENDAS	FOLHA /SHEET	1 / 1		