







OWNER:  شرکت سست و سویی گیس ایرپک (سهامی خاص)	BUSHEHR PETROCHEMICAL COMPANY MEG PLANT						EPC CONTRACTOR:  Chagalesh-Enerchimi-Steam Joint Venture BUPC-MEG PLANT PROJECT		
	INSTRUMENT HOOK UP DRAWING FOR NITROGEN GAS BOOSTER								
MC :									
Owner Document Number: 17811-38A	Project	Area	Phase	Unit	Dis.	Doc.	Seq.	Rev.:	Page
	BU	20	VD	303	IN	DWG	0033	01	1 of 12

## INSTRUMENT HOOK UP DRAWING FOR NITROGEN GAS BOOSTER

 شرکت سست و سویی گیس ایرپک (سهامی خاص)	 Chagalesh-Enerchimi-Steam Joint Venture BUPC-MEG PLANT PROJECT	BUSHEHR PETROCHEMICAL COMPANY MEG PLANT
<b>Document Review</b>		
Issue Purpose:	IFA	
Result Code: AP,AN,CM,RE,NC	CM	
Next Status : IFC,IFA,IFI,AFC,AB	IFA	
Responsible Department	MECHANICAL	
Commented Date	Dec/11/2021	
<b>Approval or review hereunder shall not be construed to relieve Vendor / Subcontractor of his responsibilities and liability under the contract.</b>		

01	16/11/2021	For approval	WZ	KP	LdM	
00	08/12/2020	For approval	WZ	KP	LdM	
Rev	Date	Purpose of Issue	Prepared	Checked	Approved	AC Code
					Class: 1	Phase: P



**BILL OF MATERIALS**

ITEM NO:	DESCRIPTION	MATERIAL	Q'TY
1	PRESSURE DIFFERENTIAL GAUGE	SS316	1
2	PROCESS CONNECTION 1/2" NPT-F	SS316	1
3	CONNECTOR DOUBLE COMPRESSION TYPE 1/4" NPT-M - 1/4" OD	SS316	4
4	TUBING 1/4" OD	SS316	-
5	2-WAY BALL VALVE 1/2" NPT-F	SS316	1
6	5-WAY BLOCK & BLEED MANIFOLD	SS316	1
7	CONNECTOR DOUBLE COMPRESSION TYPE 1/2" NPT-M - 1/2" OD	SS316	6
8	TUBING 1/2" OD	SS316	-
9	TUBING 1/4" OD WITH CAP	SS316	-
10	CONNECTOR DOUBLE COMPRESSION TYPE 1/2" NPT-M - 1/4" OD	SS316	2

TAG NO: PDG-10151

Length to be specified

- Line service shall be specified.(liquid, gas, etc.)  
 - Nozzle tap orientation shall be same as attached file, and specified in pressure hook-up pages.

NO. OF INSTALLATIONS: 1

**PRESSURE DIFFERENTIAL GAUGE**

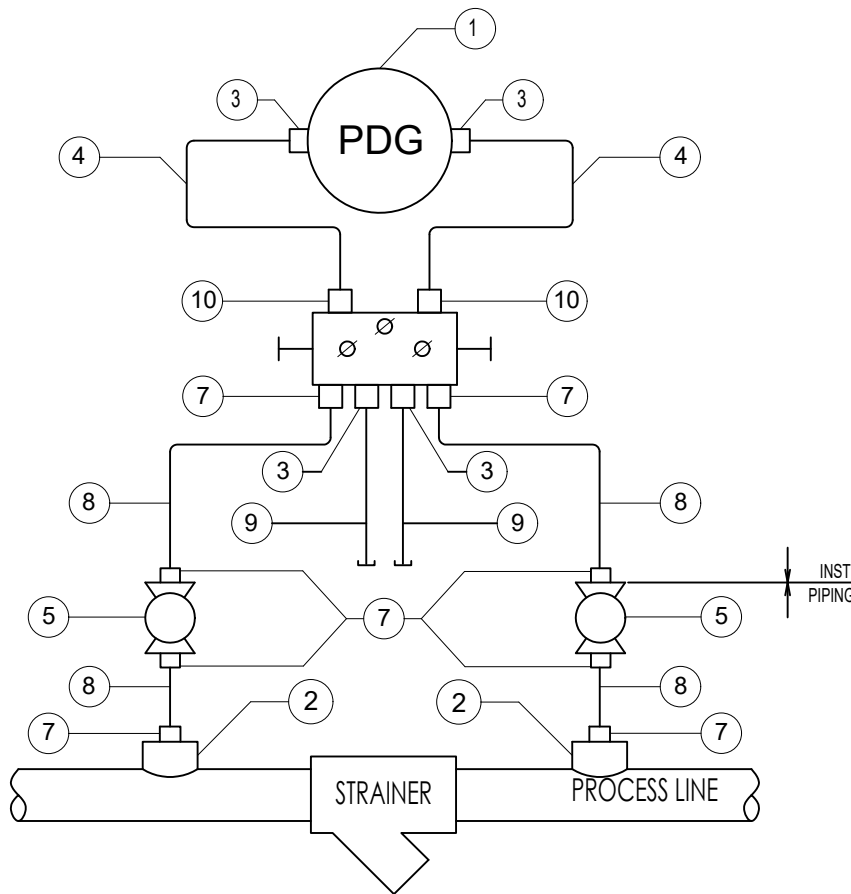

	SUBJECT		INSTRUMENT HOOK UP DRAWING FOR NITROGEN COMPRESSOR		DATE	07-12-2020	THIS DRAWING IS OWNED BY AIRPACK AND SHALL NOT BE PRINTED OR COPIED IN ANY OTHER WAY THAN WITH AIRPACKS PERMISSION 01 15-11-2021 VZ 00 07-12-2020 VZ
	CLIENT	Bushehr Petrochemical Company (BUPC)		PLANT LOCATION	IRAN, DNSHORE		
	CLIENT REF	17811		SCALE	-		
	AIRPACK REF	17811-CDM		DRAWING NO.	17811-38		
				MODIFICATIONS	SHEET	01/10	

**BILL OF MATERIALS**

ITEM NO:	DESCRIPTION	MATERIAL	Q'TY
1	PRESSURE GAUGE	SS316	1
2	PROCESS CONNECTION 1/2" NPT-F	SS316	6
3	CONNECTOR DOUBLE COMPRESSION TYPE 1/2" NPT-M - 1/2" OD	SS316	1
4	TUBING 1/2" OD	SS316	-
5	2-WAY BALL VALVE 1/2" NPT-F	SS316	1
6	2-WAY BLOCK & BLEED MANIFOLD	SS316	1
7	CONNECTOR DOUBLE COMPRESSION TYPE 1/4" NPT-F - 1/4" OD	SS316	1
8	TUBING 1/4" OD WITH CAP	SS316	-

TAG NO: PG-10152 / PG-10155 / PG-10160 / PG-10161

- Line service shall be specified.(liquid, gas, etc.)  
 - Nozzle tap orientation shall be same as attached file, and specified in pressure hook-up pages.

Length to be specified

NO. OF INSTALLATIONS: 4

**PRESSURE GAUGE**

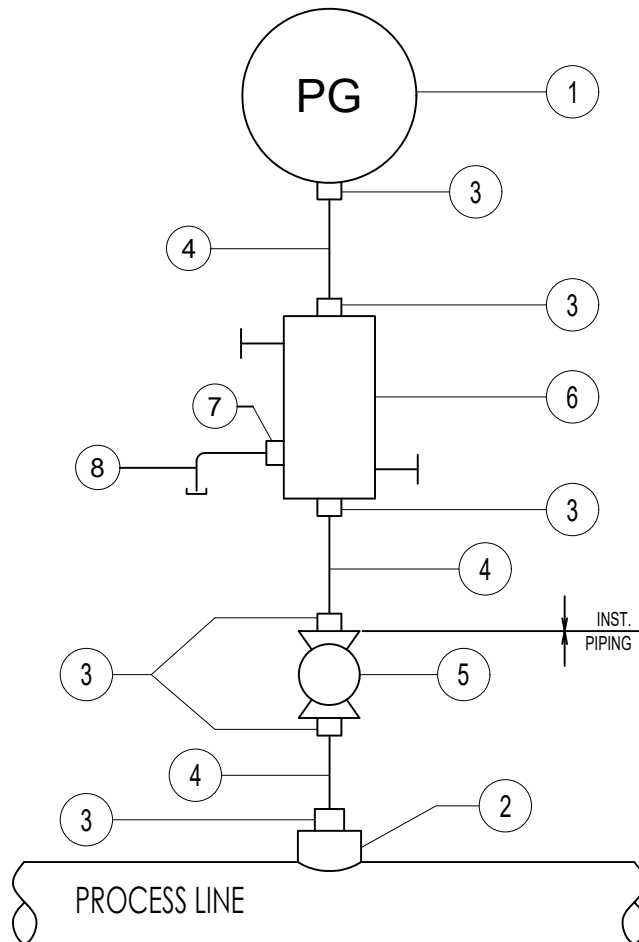

SUBJECT		INSTRUMENT HOOK UP DRAWING FOR NITROGEN COMPRESSOR		DATE	07-12-2020	THIS DRAWING IS OWNED BY AIRPACK AND SHALL NOT BE PRINTED OR COPIED IN ANY OTHER WAY THAN WITH AIRPACKS PERMISSION			
CLIENT		Bushehr Petrochemical Company (BUPC)		DRAWN BY	WZ				
CLIENT REF		17811		CHECKED BY	KP				
AIRPACK REF		17811-CDM		PLANT LOCATION	IRAN, DNSHORE				
				SCALE	-		01	15-11-2021	VZ
				DRAWING NO.	17811-38		00	07-12-2020	VZ
						MODIFICATIONS	SHEET	02/10	



**BILL OF MATERIALS**

ITEM NO:	DESCRIPTION	MATERIAL	Q'TY
1	PRESSURE TRANSMITTER	ALUMINIUM	1
2	PROCESS CONNECTION 1/2" NPT-F	SS316	6
3	CONNECTOR DOUBLE COMPRESSION TYPE 1/2" NPT-M - 1/2" OD	SS316	1
4	TUBING 1/2" OD	SS316	-
5	2-WAY BALL VALVE 1/2" NPT-F	SS316	1
6	2-WAY BLOCK & BLEED MANIFOLD	SS316	1

TAG NO: PIT-10153 / PIT-10154 / PIT-10156 / PIT-10157 / PIT-10158 / PIT-10159

- Line service shall be specified.(liquid, gas, etc.)
- Nozzle tap orientation shall be same as attached file, and specified in pressure hook-up pages.
- Tube and cap to be considered for drain /vent of manifold.

Length to be specified

NO. OF INSTALLATIONS: 6

**PRESSURE TRANSMITTER**

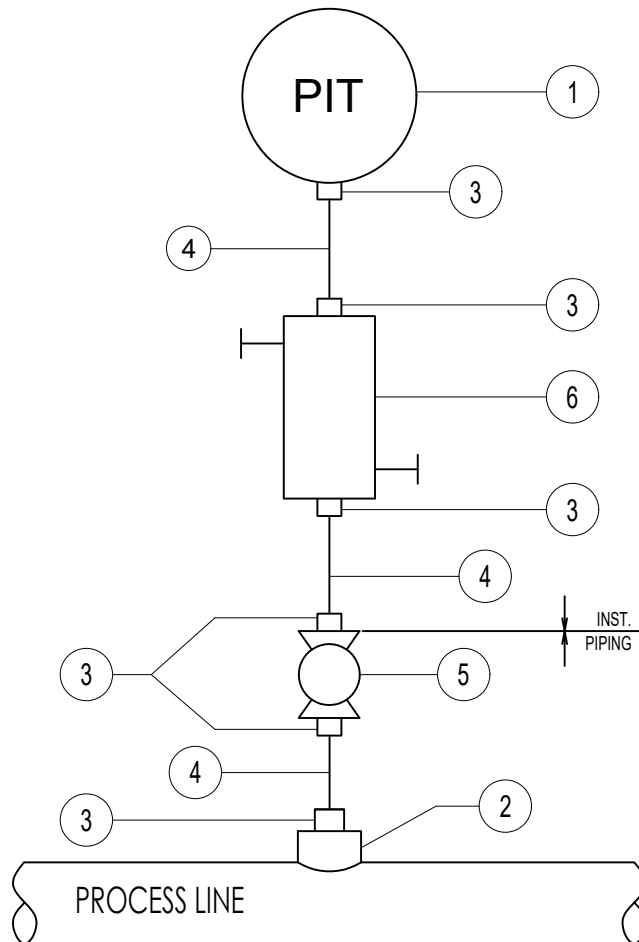

	SUBJECT		INSTRUMENT HOOK UP DRAWING FOR NITROGEN COMPRESSOR		DATE	07-12-2020	THIS DRAWING IS OWNED BY AIRPACK AND SHALL NOT BE PRINTED OR COPIED IN ANY OTHER WAY THAN WITH AIRPACKS PERMISSION			
	CLIENT	Bushehr Petrochemical Company (BUPC)		PLANT LOCATION	IRAN, DNSHORE			01	15-11-2021	VZ
	CLIENT REF	17811		SCALE	-			00	07-12-2020	VZ
	AIRPACK REF	17811-COM		DRAWING NO.	17811-38			MODIFICATIONS	SHEET 04/10	

**BILL OF MATERIALS**

ITEM NO:	DESCRIPTION	MATERIAL	Q'TY
1	TEMPERATURE TRANSMITTER	ALUMINIUM	1
2	PROCESS CONNECTION 1 1/2" ANSI 300# RF	SS316	1
3	THERMOWELL 1 1/2" ANSI 300# RF	SS316	1
4	CONNECTOR DOUBLE COMPRESSION FITTING 1/2" NPT-M - 6 MM OD	SS316	1
5	CAPILARY, L=5M MOULDED TO TEMPERATURE ELEMENT	SS316	1

TAG NO: TIT-10151 / TIT-10152 / TIT-10153 / TIT-10154 / TIT-10155

NO. OF INSTALLATIONS: 4

## TEMPERATURE TRANSMITTER

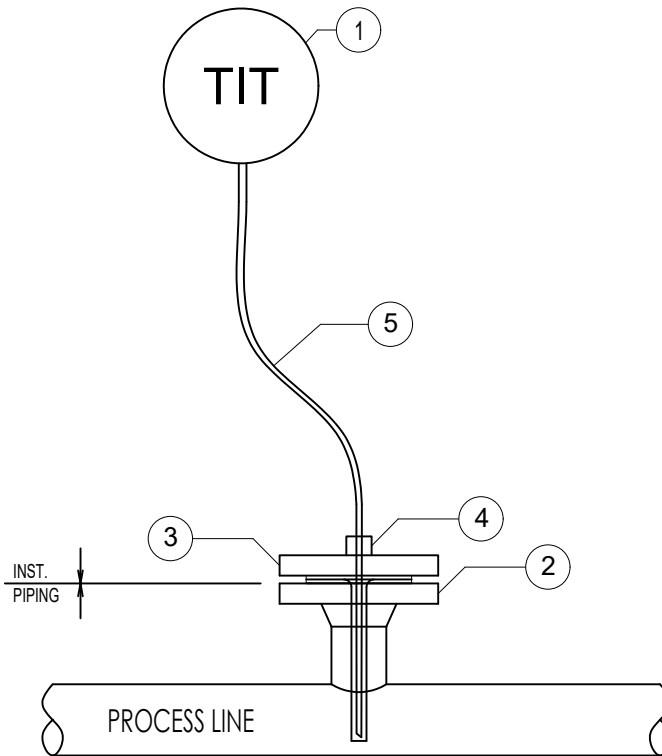

	SUBJECT		INSTRUMENT HOOK UP DRAWING FOR NITROGEN COMPRESSOR		DATE	07-12-2020	THIS DRAWING IS OWNED BY AIRPACK AND SHALL NOT BE PRINTED OR COPIED IN ANY OTHER WAY THAN WITH AIRPACKS PERMISSION 01 15-11-2021 VZ 00 07-12-2020 VZ
	CLIENT	Bushehr Petrochemical Company (BUPC)		PLANT LOCATION	IRAN, DNSHORE		
	CLIENT REF	17811		SCALE	-		
	AIRPACK REF	17811-COM		DRAWING NO.	17811-38		
	MODIFICATIONS		SHEET		05/10		

**BILL OF MATERIALS**

ITEM NO:	DESCRIPTION	MATERIAL	Q'TY
1	VORTEX FLOW TRANSMITTER	ALUMINIUM	1
2	PROCESS CONNECTION 1 1/2" ANSI 150# RF	SS 316	2

TAG NO: FT-10151

NO. OF INSTALLATIONS: 1

## FLOW TRANSMITTER

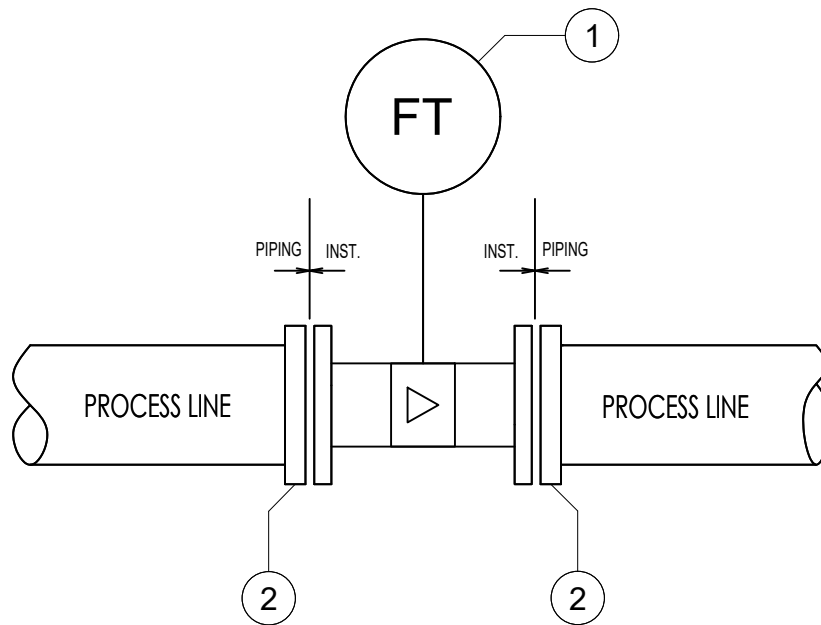

	SUBJECT		INSTRUMENT HOOK UP DRAWING FOR NITROGEN COMPRESSOR		DATE	07-12-2020	THIS DRAWING IS OWNED BY AIRPACK AND SHALL NOT BE PRINTED OR COPIED IN ANY OTHER WAY THAN WITH AIRPACKS PERMISSION			
	CLIENT	Bushehr Petrochemical Company (BUPC)		PLANT LOCATION	IRAN, DNSHORE					
	CLIENT REF	17811		SCALE	-			01	15-11-2021	VZ
	AIRPACK REF	17811-COM		DRAWING NO.	17811-38			00	07-12-2020	VZ
							MODIFICATIONS	SHEET	06/10	

**BILL OF MATERIALS**

ITEM NO:	DESCRIPTION	MATERIAL	Q'TY
1	3-WAY SOLENOID VALVE	SS 316	1
2	CONNECTOR DOUBLE COMPRESSION TYPE 1/4" NPT-M - 1/4" OD	SS 316	3
3	TUBING 1/4" OD	SS 316	-

TAG NO: XY-10151

- Air header and required connection to be specified.  
 - Vendor to clarify, whether filter/regulator is required before solenoid valve.

NO. OF INSTALLATIONS: 1

## SOLENOID VALVE

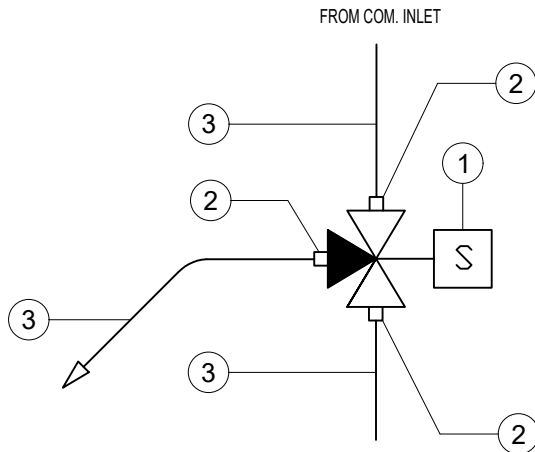

SUBJECT		INSTRUMENT HOOK UP DRAWING FOR NITROGEN COMPRESSOR		DATE	07-12-2020	THIS DRAWING IS OWNED BY AIRPACK AND SHALL NOT BE PRINTED OR COPIED IN ANY OTHER WAY THAN WITH AIRPACKS PERMISSION			
CLIENT		Bushehr Petrochemical Company (BUPC)		DRAWN BY	WZ				
CLIENT REF		17811		CHECKED BY	KP				
AIRPACK REF		17811-COM		PLANT LOCATION	IRAN, DNSHORE				
				SCALE	-		01	15-11-2021	WZ
				DRAWING NO.	17811-38		00	07-12-2020	WZ
				MODIFICATIONS			SHEET		07/10

**BILL OF MATERIALS**

ITEM NO:	DESCRIPTION	MATERIAL	Q'TY
1	2-WAY BALL VALVE 1 1/2" ANSI 150# RF	SS 316	1
2	CONNECTOR DOUBLE COMPRESSION TYPE 1/4" NPT-M - 1/4" OD	SS 316	4
3	3-WAY SOLENOID VALVE	SS 316	1
4	TUBING 1/4" OD	SS 316	-

TAG NO: XV-10152  
XY-10152

Please refer to attached file for air hook-up

NO. OF INSTALLATIONS: 2

**PNEUMATIC OPERATED BALL VALVE**

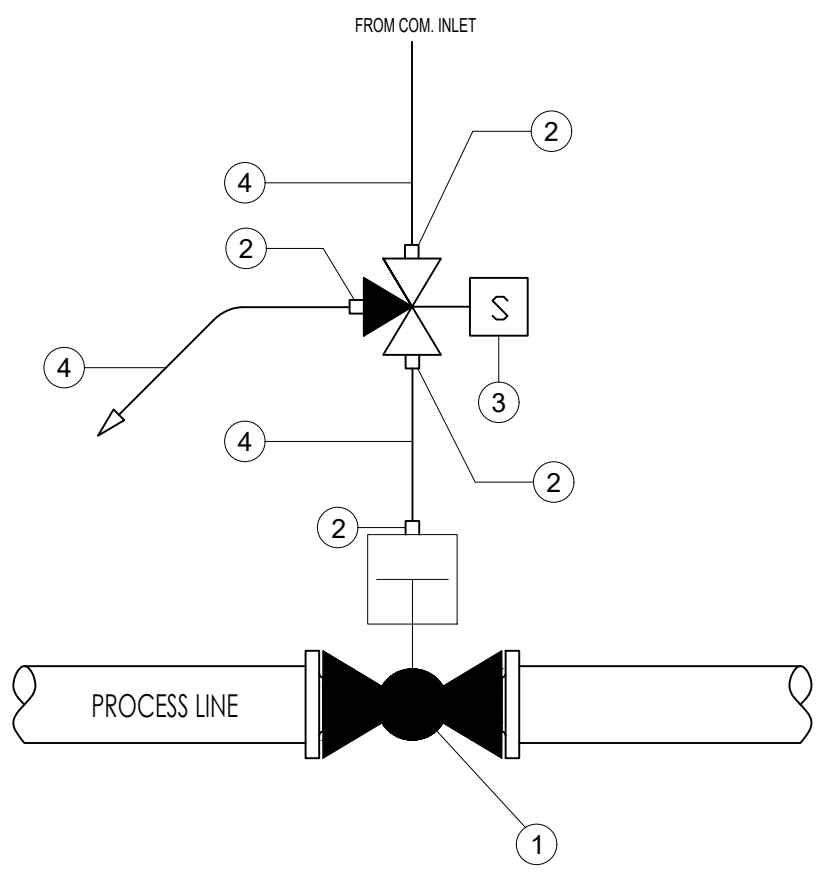

SUBJECT		INSTRUMENT HOOK UP DRAWING FOR NITROGEN COMPRESSOR		DATE	07-12-2020	THIS DRAWING IS OWNED BY AIRPACK AND SHALL NOT BE PRINTED OR COPIED IN ANY OTHER WAY THAN WITH AIRPACKS PERMISSION			
CLIENT	Bushehr Petrochemical Company (BUPC)	PLANT LOCATION	IRAN, DNSHORE	DRAWN BY	WZ				
CLIENT REF	17811	SCALE	-	CHECKED BY	KP		01	15-11-2021	VZ
AIRPACK REF	17811-COM	DRAWING NO.	17811-38	MODIFICATIONS			00	07-12-2020	VZ
						SHEET	08	10	

**BILL OF MATERIALS**

ITEM NO:	DESCRIPTION	MATERIAL	Q'TY
1	PRESSURE CONTROL VALVE 1" ANSI 300# RF	SS 316	1
2	FLANGE 1" ANSI 300# RF	SS 316	1
3	CONNECTOR DOUBLE COMPRESSION TYPE 1/4" NPT-M - 1/4" OD	SS 316	1
4	TUBING 1/4" OD	SS 316	1

TAG NO: PV-10151

Please refer to attached file for air hook-up

NO. OF INSTALLATIONS: 1

**PRESSURE RECYCLE VALVE**

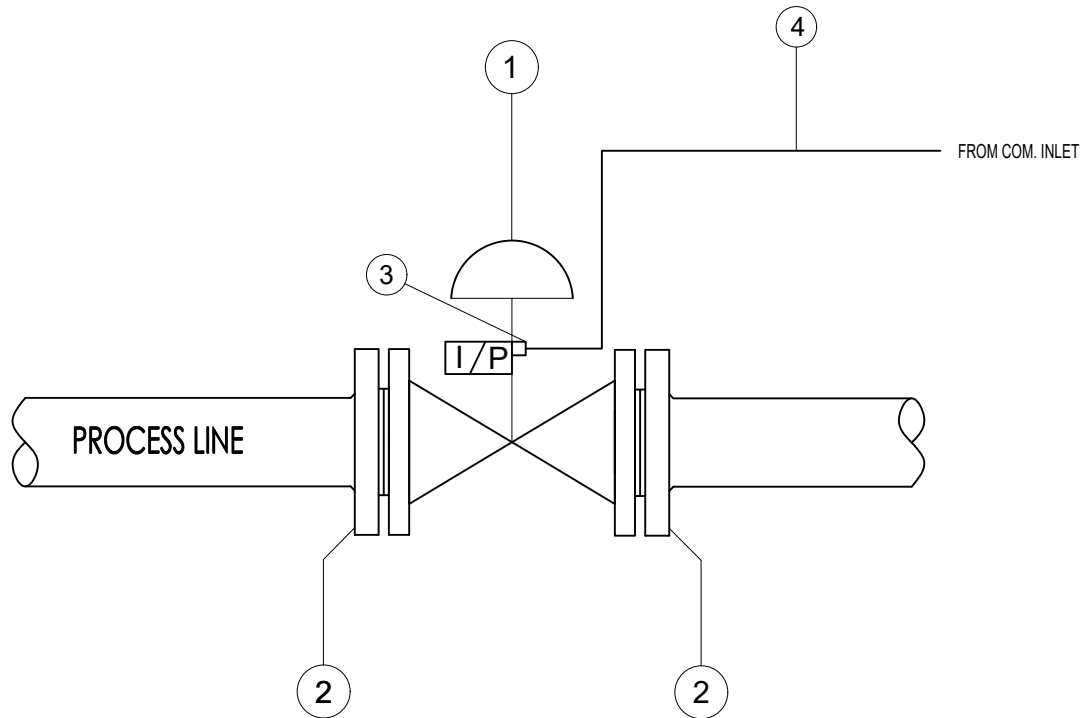

	SUBJECT		INSTRUMENT HOOK UP DRAWING FOR NITROGEN COMPRESSOR		DATE	07-12-2020	THIS DRAWING IS OWNED BY AIRPACK AND SHALL NOT BE PRINTED OR COPIED IN ANY OTHER WAY THAN WITH AIRPACKS PERMISSION 01 15-11-2021 VZ 00 07-12-2020 VZ
	CLIENT	Bushehr Petrochemical Company (BUPC)		PLANT LOCATION	IRAN, DNSHORE		
	CLIENT REF	17811		SCALE	-		
	AIRPACK REF	17811-COM		DRAWING NO.	17811-38		
MODIFICATIONS		SHEET		09/10			

