







OWNER:  شرکت سست و سویی گیس ایران (سهامی خاص)	BUSHEHR PETROCHEMICAL COMPANY MEG PLANT							EPC CONTRACTOR:  Chagalesh-Enerchimi-Steam Joint Venture BUPC-MEG PLANT PROJECT	
	COMPRESSOR MOTOR OUTLINE DRAWING & TERMINAL BOX WIRING DIAGRAM FOR NITROGEN GAS BOOSTER							 Netherlands	
MC :  شرکت سست و سویی گیس ایران (سهامی خاص)	Project	Area	Phase	Unit	Dis.	Doc.	Seq.	Contract No: 52-98/445	
Owner Document Number: 17811-39A	BU	20	VD	303	EL	DWG	0053	Rev.:	Page
								02	1 of 5

COMPRESSOR MOTOR OUTLINE DRAWING & TERMINAL BOX WIRING DIAGRAM FOR NITROGEN GAS BOOSTER

 شرکت سست و سویی گیس ایران (سهامی خاص)	 Chagalesh-Enerchimi-Steam Joint Venture BUPC-MEG PLANT PROJECT	BUSHEHR PETROCHEMICAL COMPANY MEG PLANT
Document Review		
Issue Purpose:	IFA	
Result Code: AP,AN,CM,RE,NC	AN	
Next Status : IFC,IFA,IFI,AFC,AB	AFC	
Responsible Department	MECHANICAL	
Commented Date	Jan/20/2022	

Approval or review hereunder shall not be construed to relieve Vendor / Subcontractor of his responsibilities and liability under the contract.

02	06/01/2022	For approval	KP	LdM	JR	
01	10/12/2021	For approval	KP	LdM	JR	
00	08/12/2020	For approval	KP	LdM	JR	
Rev.	Date	Purpose of Issue	Prepared	Checked	Approved	AC Code
					Class: 1	Phase: P

Nitrogen Gas Booster 20-C-1002-M

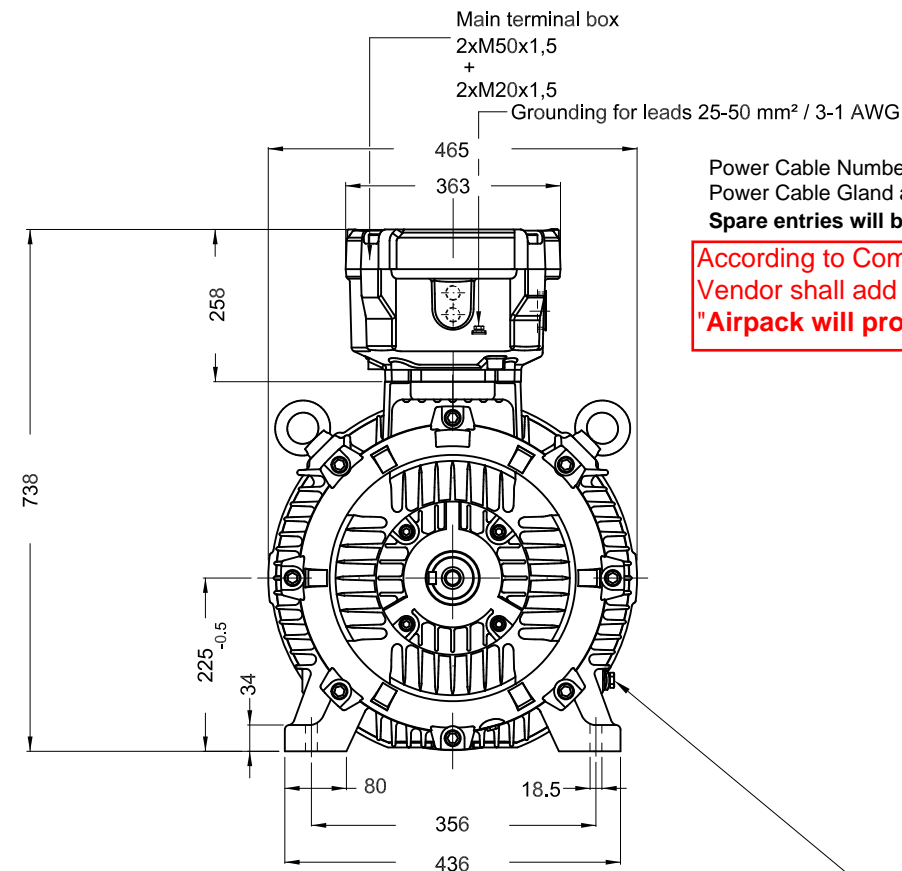

Power Cable Number and Size: 4 x 25 mm²
 Power Cable Gland and Entries: 1 x M40
 Spare entries will be plugged

According to Comment/Reply Sheet:
 Vendor shall add this note:
"Airpack will provide suitable adapter"

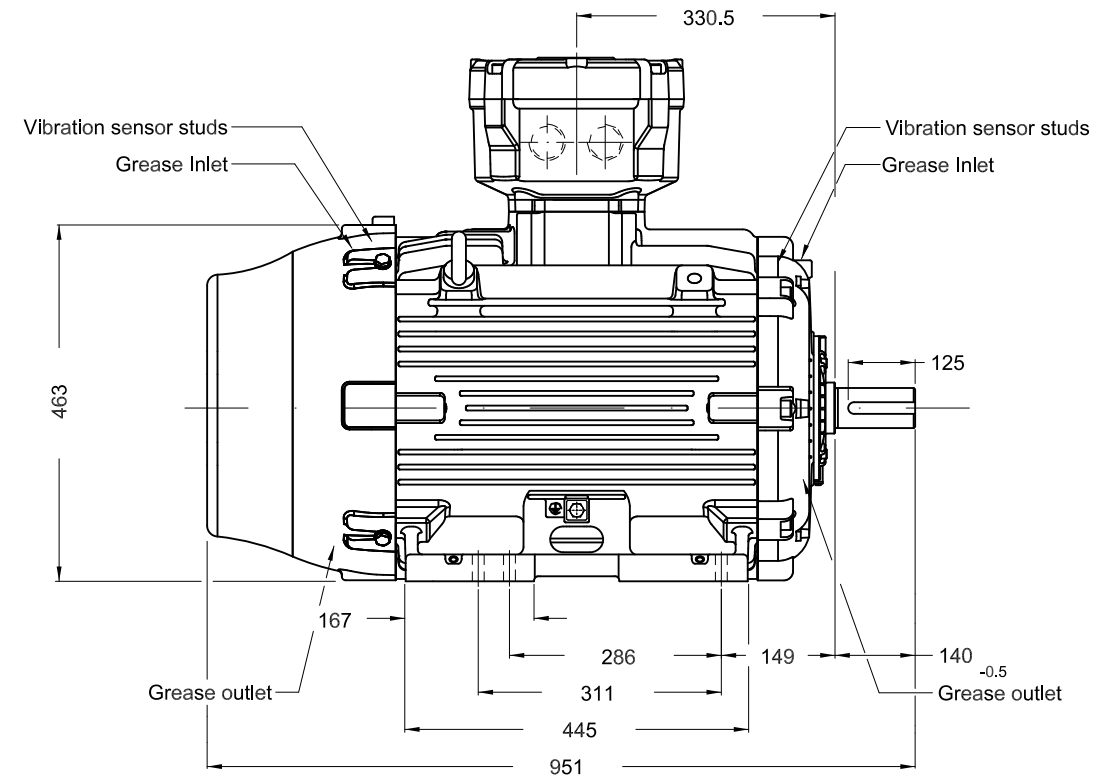

Grounding for leads 25-50 mm² / 3-1 AWG

According to "Earthing SPEC.", Suitable earth cable size for this motor is 35mm².
 Vendor is responsible for considering all necessary requirements.
 Vendor shall confirm it in order to be closed this comment.

- Tropicalized internal painting
- DE roller bearing
- Shaft locking device
- Shaft material - AISI/SAE 4140
- SPM studs
- Color RAL 5010
- Painting plan 205P
- Mounting B3T

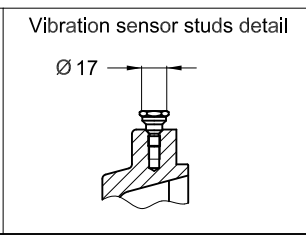
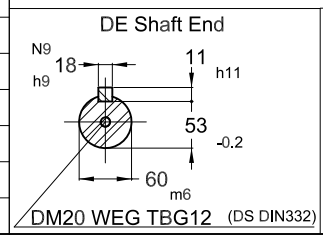

45 kW 04 Poles 50 Hz										A						
ECM										LOC	SUMMARY OF MODIFICATIONS	EXECUTED	CHECKED	RELEASED	DATE	VER
EXECUTED	PIRWBUSER		THREE PH. MOTOR W22Xdb IE4 Ex d IIB T4		PREVIEW											
CHECKED			FRAME 225S/M IP56 TEFC		WDD											
RELEASED			Main Compressor Motor 20-C-1002-M 45kW		WEG											
REL DT.			WMO Jaragua do Sul		Product Engineering		SHEET			03/05						

Dimensional drawing subject to change. We reserve the right to change constructional details.
 * Detail out of scale.

A



B

C

D

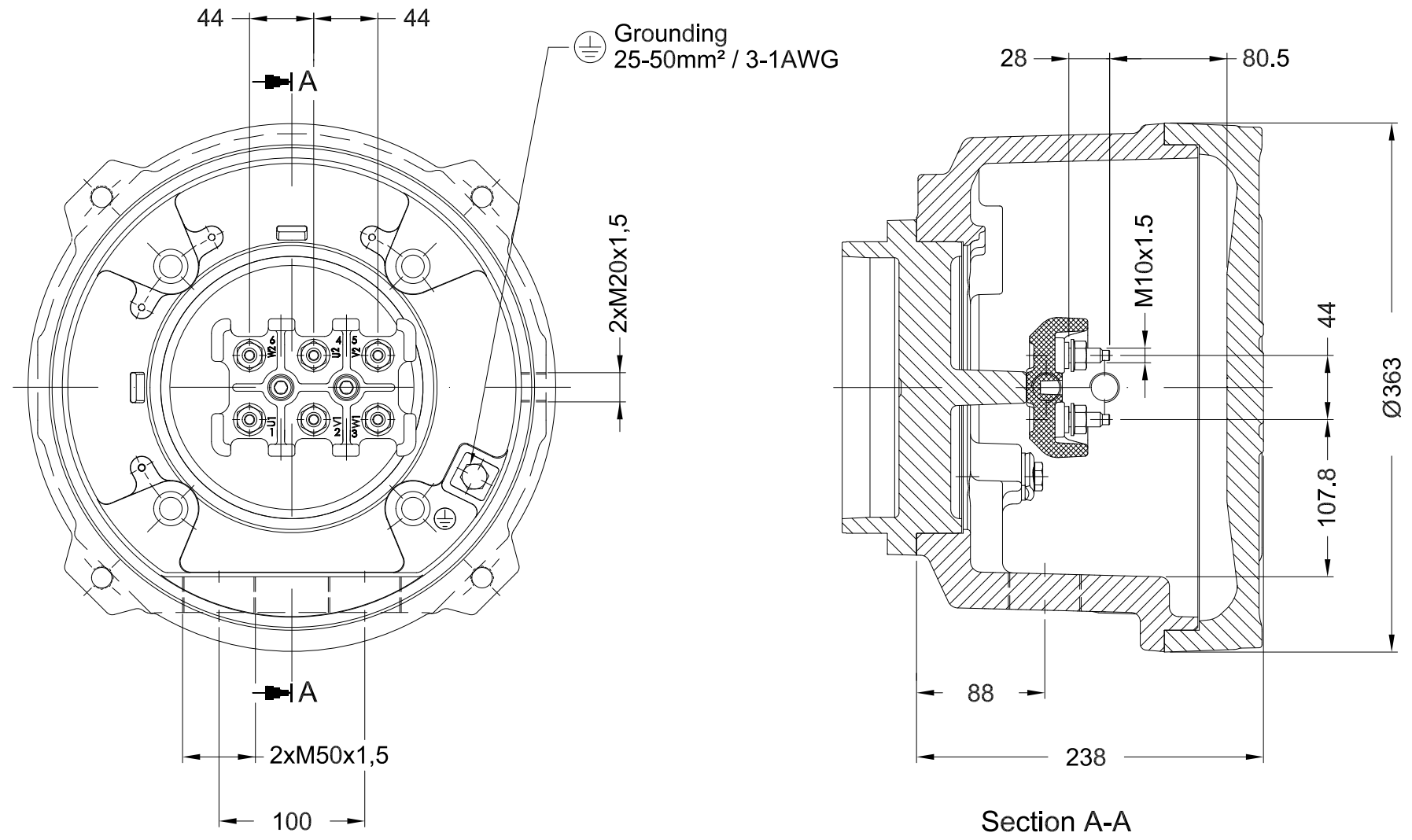
E

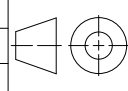

				ESC	1:4				
ECM	LOC	SUMMARY OF MODIFICATIONS		EXECUTED	CHECKED	RELEASED	DATE	VER	
EXECUTED	YDAMHUIS	 MAIN TERMINAL BOX FRAME 225S/M		PREVIEW WCD					
CHECKED								SHEET	04/05
RELEASED									
REL DT.									

THIS IS AN UPDATED REVISION, THE PREVIOUS ONE MUST BE DISREGARDED.

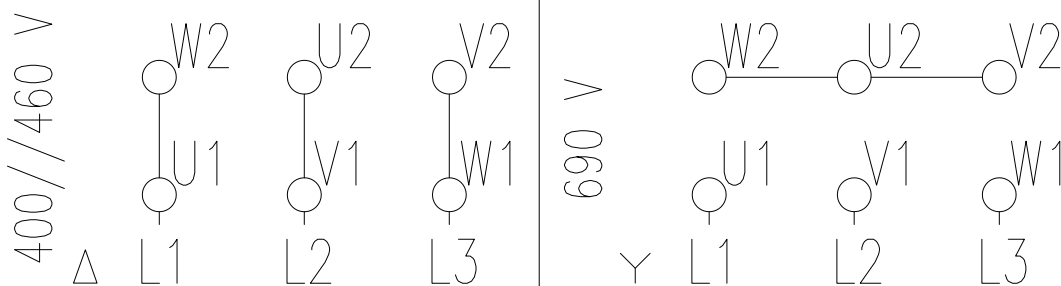

A

B

C

D

E

		ORIGINAL ISSUE		JESSICA	PATRICIA	CASTELLA	30.10.2018	00
ECM ECM	LOC LOC	RESUMO MODIFICAÇÃO SUMMARY OF MODIFICATIONS		EXECUTADO EXECUTED	VERIFICADO CHECKED	LIBERADO RELEASED	DATA DATE	VER VER
EXEC. /EXECUTED	JESSICA		LOW VOLTAGE - CONNECTION DIAGRAM 400/690//460V MOTOR WITH 06 CABLES	400/690//460-6				
VERIF. /CHECKED	PATRICIA			IEC	00			
LIBER. /RELEASED	CASTELLA							
DATA LB /REL DT	30.10.2018	WMO	JARAGUÁ DO SUL	ADMINISTRAÇÃO DE VENDAS	FOLHA /SHEET	05/05		