







OWNER:  شرکت سست و سویی توسعه ایران پتروشیمی (سهامی عامه)	BUSHEHR PETROCHEMICAL COMPANY MEG PLANT						EPC CONTRACTOR:  Chagalesh-Enerchimi-Steam Joint Venture BUPC-MEG PLANT PROJECT		
	PULSATION DAMPER MECHANICAL STRENGHT CALCULATION FOR NITROGEN GAS BOOSTER						 Netherlands		
MC :  شرکت سست و سویی توسعه ایران پتروشیمی (سهامی عامه)	Project	Area	Phase	Unit	Dis.	Doc.	Seq.	Contract No : 52-98/445	
Owner Document Number: 17811-24C	BU	20	VD	303	ME	CAL	0026	Rev.:	Page
								01	1 of 113

Repetitive comment:
 1- Wind and seismic (as per ASCE 7-16 (see report in page 13 of requisition)) effect for design all pressure vessels (even if located inside of package) shall be considered by vendor.
 2- As per clause M8 of nitrogen compressor TCL, native PV ELITE file shall be submitted by vendor (see enclosed TCL of nitrogen compressor).



PULSATION DAMPER MECHANICAL STRENGHT CALCULATION FOR NITROGEN GAS BOOSTER

 شرکت سست و سویی توسعه ایران پتروشیمی (سهامی عامه)	 Chagalesh-Enerchimi-Steam Joint Venture BUPC-MEG PLANT PROJECT	BUSHEHR PETROCHEMICAL COMPANY MEG PLANT
Document Review		
Issue Purpose:	IFA	
Result Code: AP,AN,CM,RE,NC	CM	
Next Status : IFC,IFA,IFI,AFC,AB	IFA	
Responsible Department	MECHANICAL	
Commented Date	May/12/2022	
Approval or review hereunder shall not be construed to relieve Vendor / Subcontractor of his responsibilities and liability under the contract.		

		Issue for approval				
01	09/05/2022	For Information	KP	CL	JR	
00	26/04/2022	For Information	KP	CL	JR	
Rev.	Date	Purpose of Issue	Prepared	Checked	Approved	AC Code
					Class: 1	Phase: P

Report – 1-stage Discharge_LI4734

PV-Elite Calculation Summary

Client: Airpack Nederland BV.
Client location: Zierikzee
Ref number client: 17811-OO-0702(KP)

PPV Engineering

Author: H.Hoezen
- Telephone: +31 (0)594 581010
- E-mail: h.hoezen@ppv-engineering.nl

April 19, 2022
Order number: P22-115-01
Document number: 22-11501-C02
Revision: 0

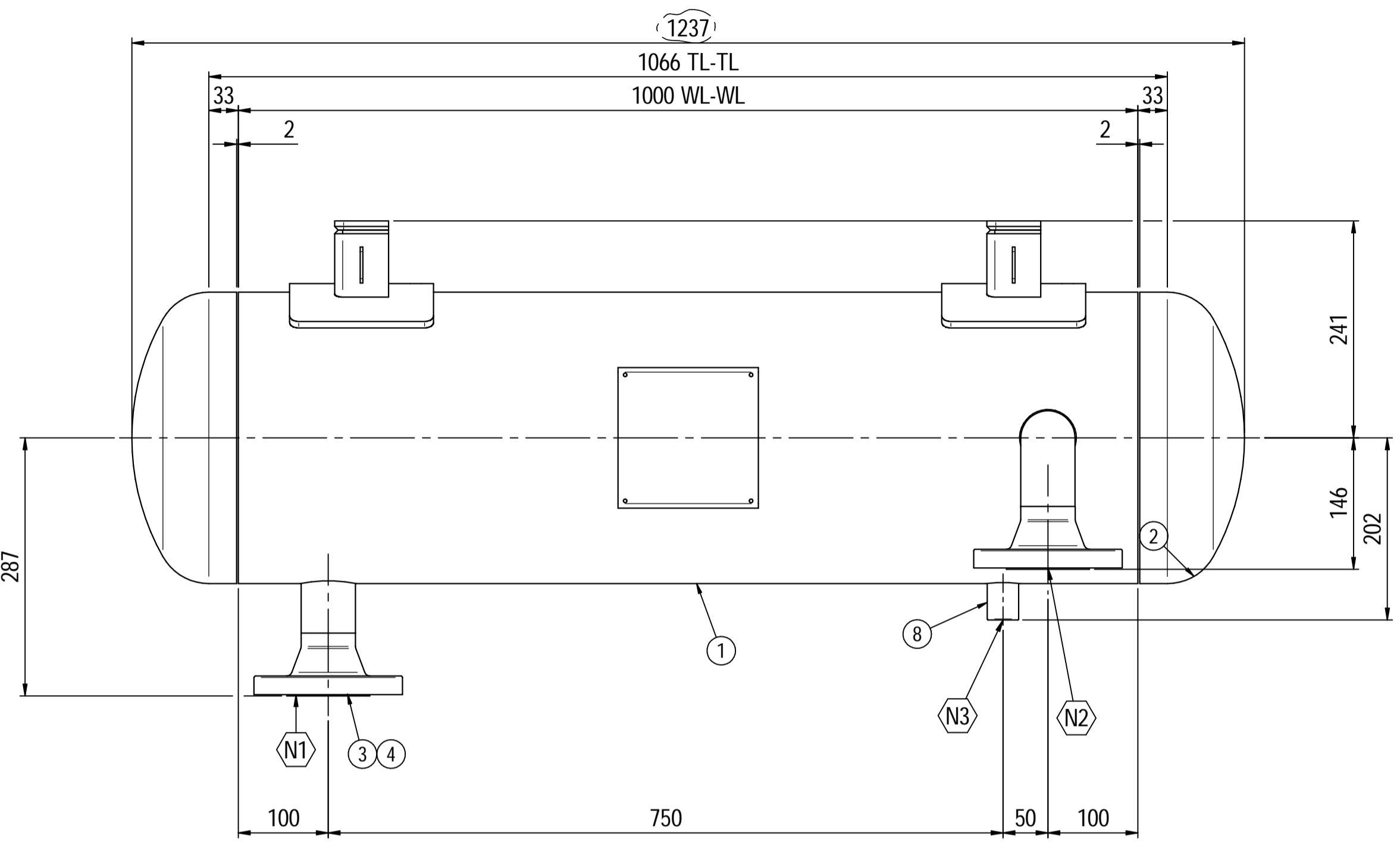
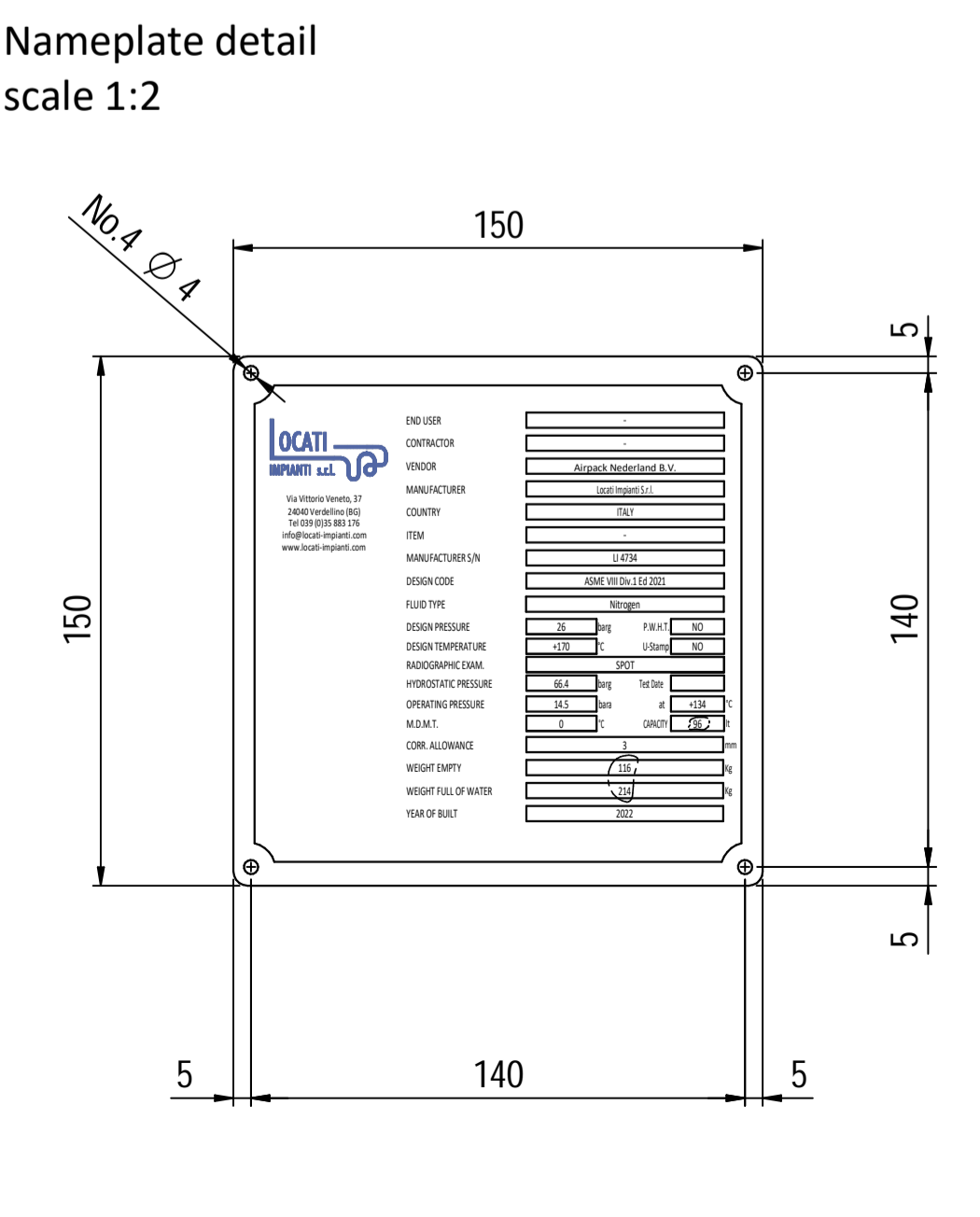
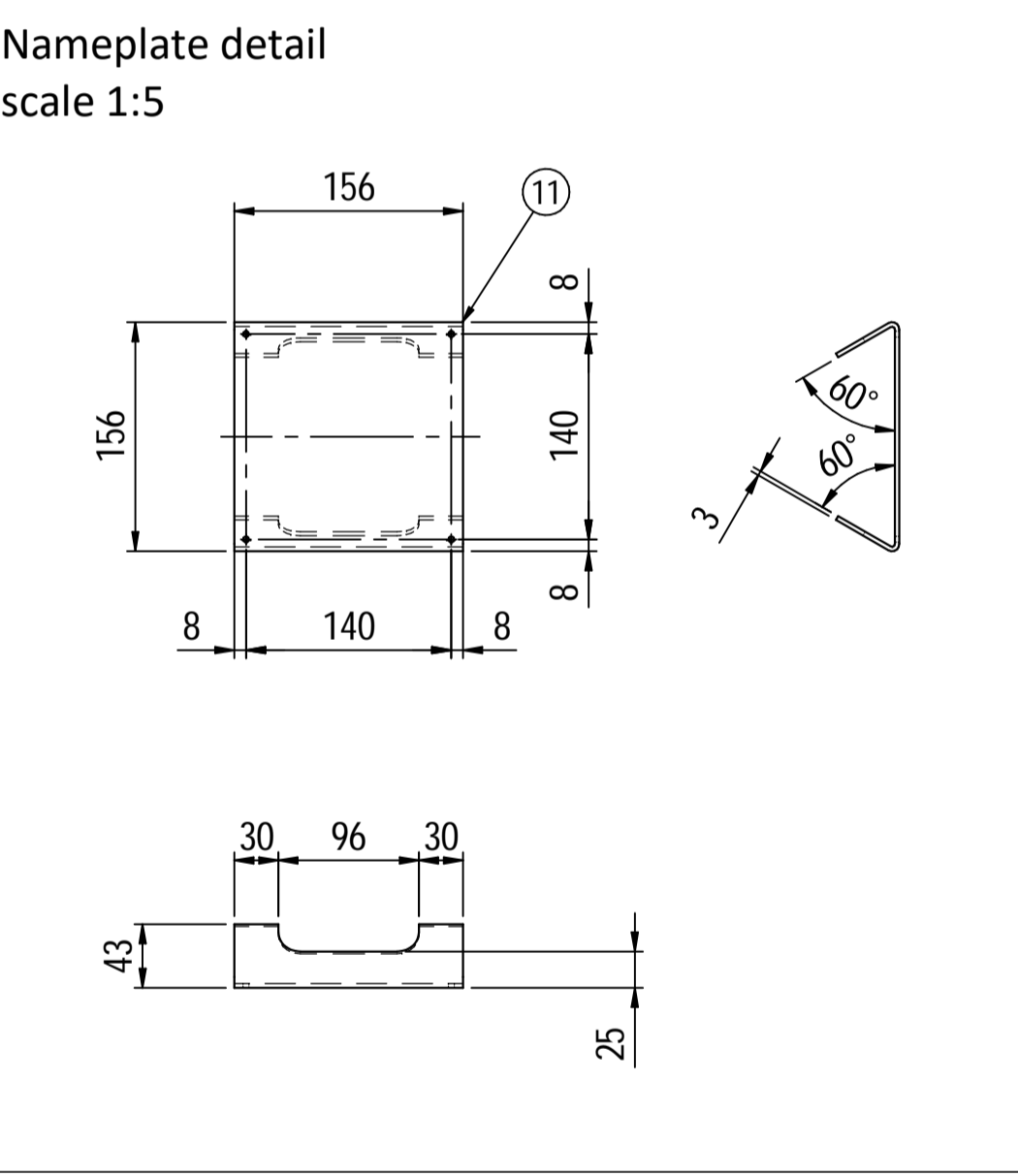
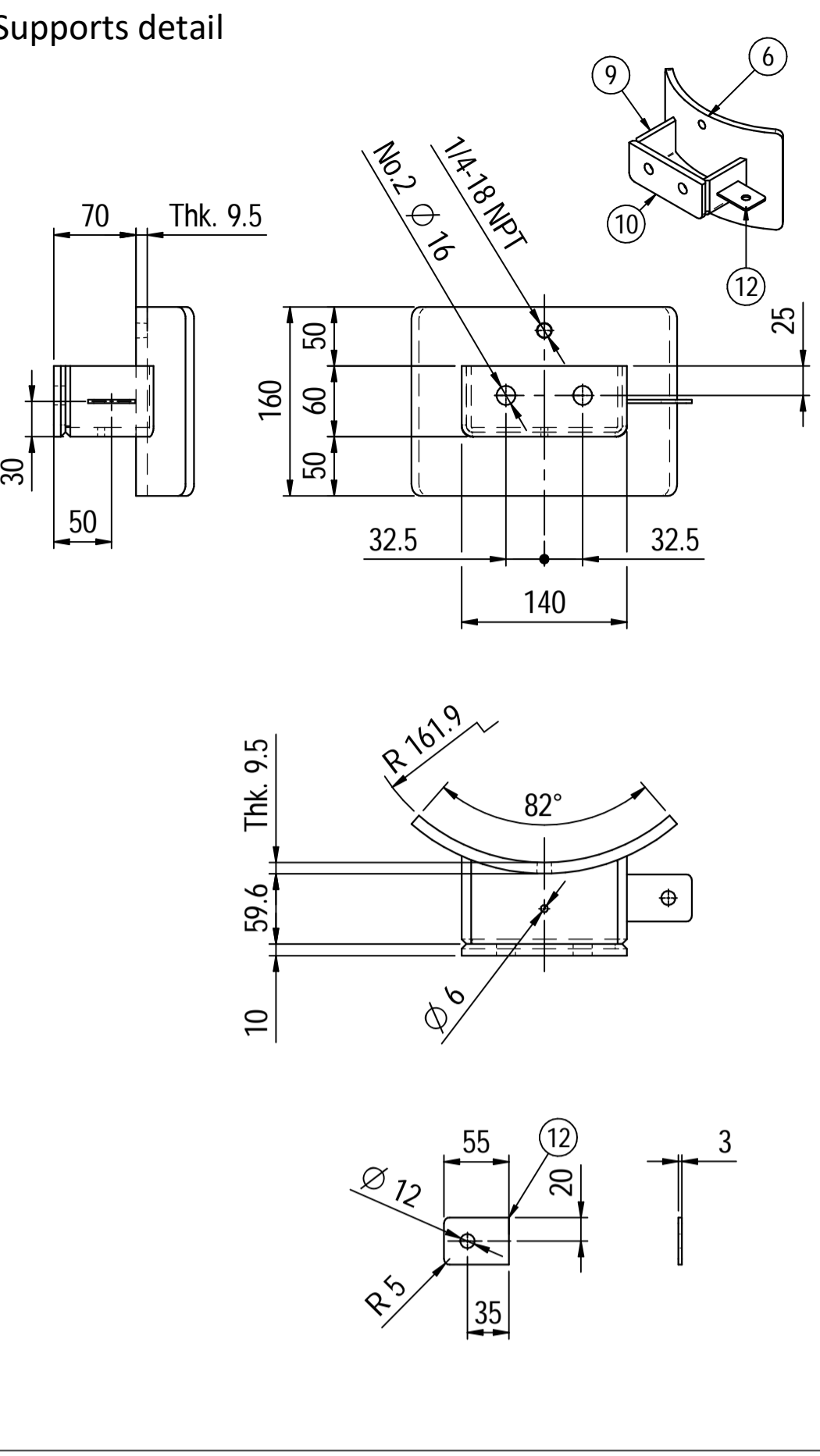

ELEVATION VIEW

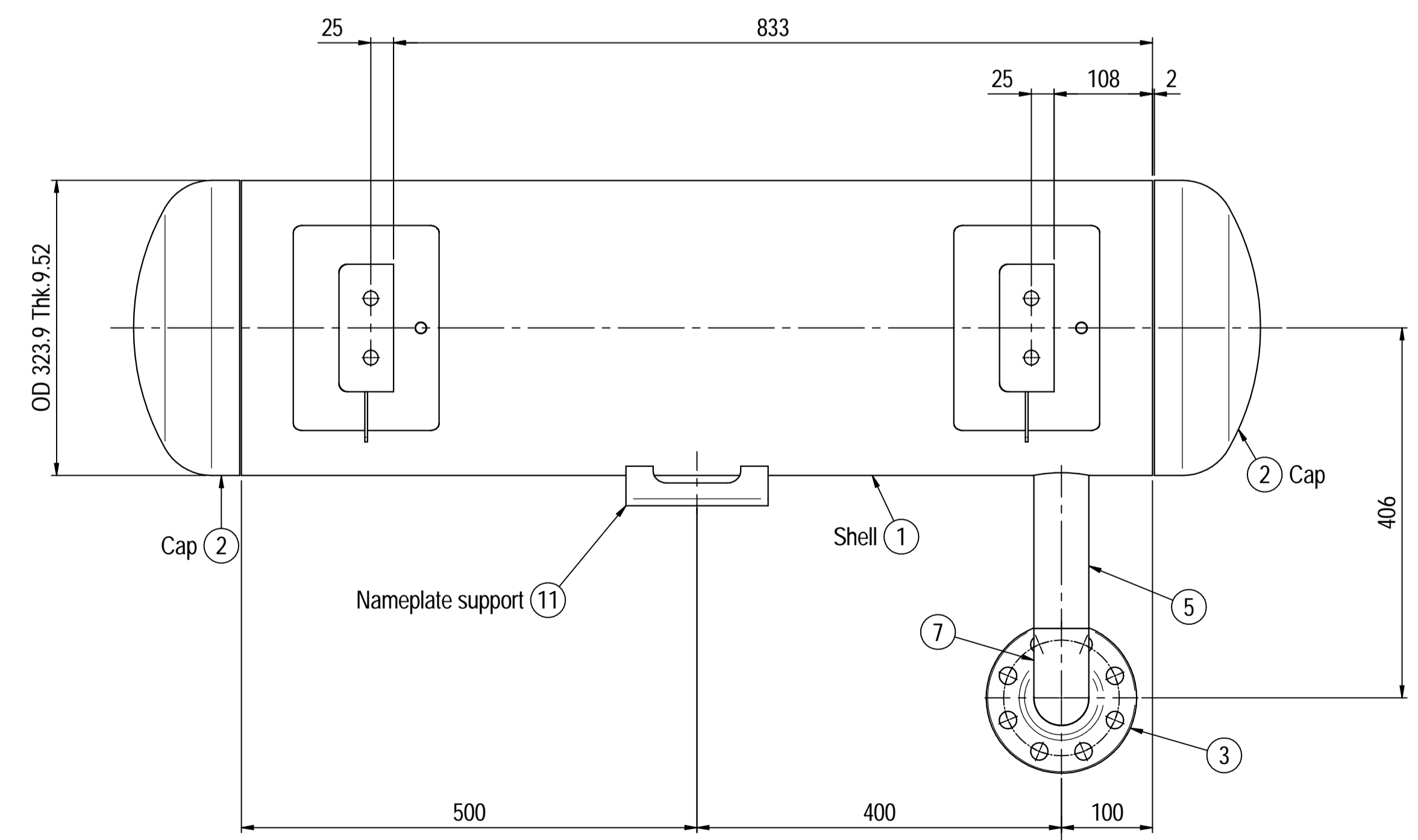

PLAN VIEW

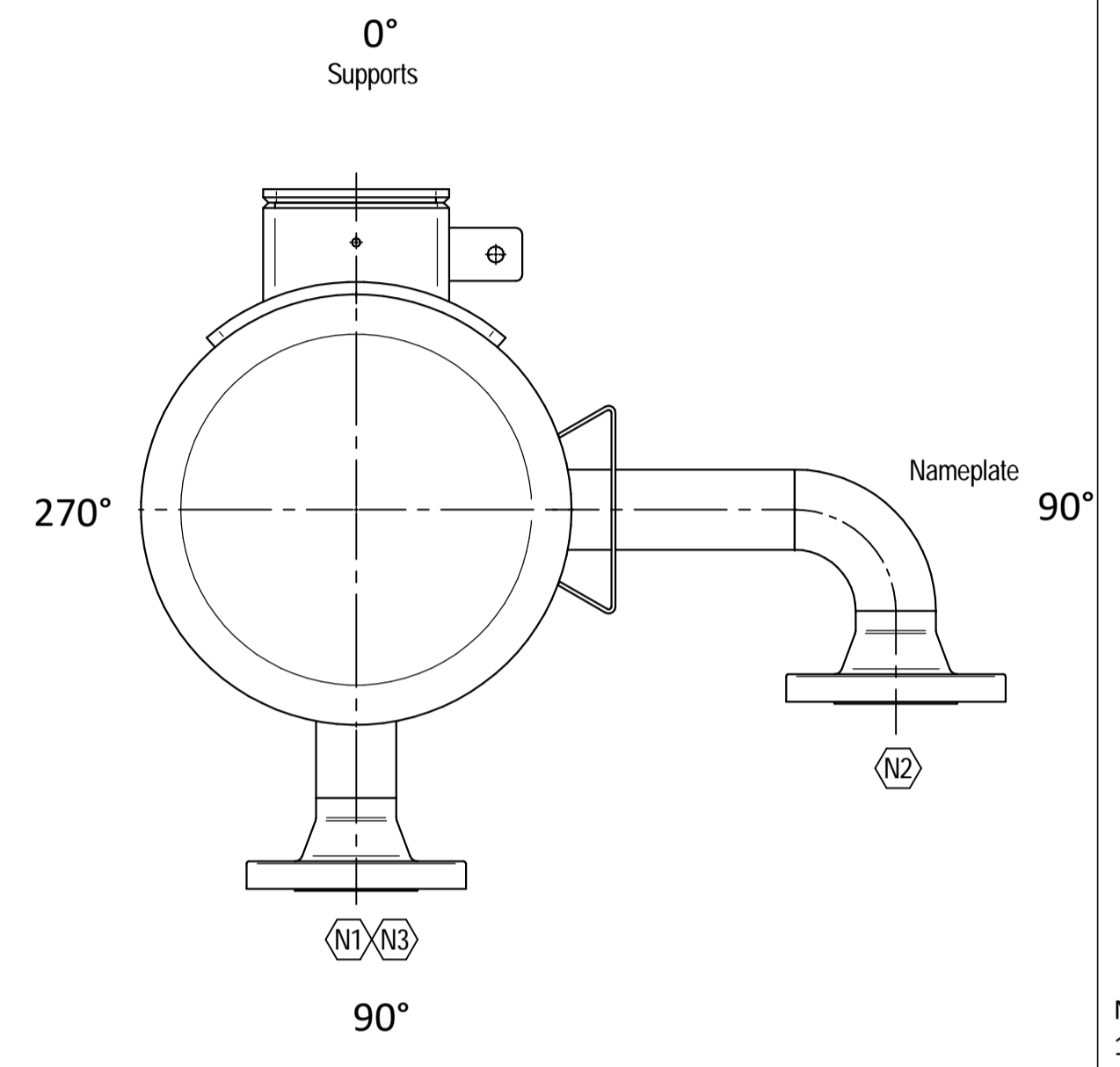

ORIENTATION VIEW

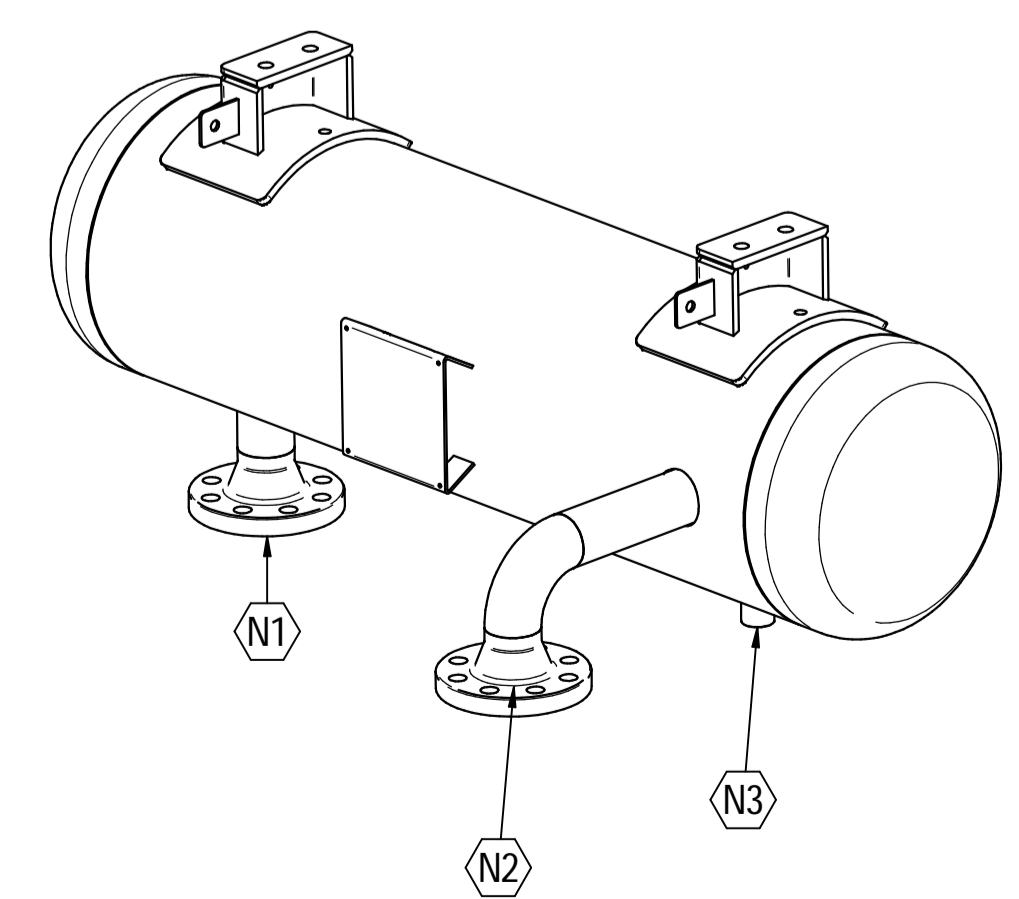

ISOMETRIC VIEW scale 1:8

Material List					
Pos.	Q.ty	Description	Mat.	Cert.	
1	1	Shell by pipe 12" Sch.STD L=1000	SA106 Gr.B	3.1	
2	2	Reduced cap 12" Sch.STD	SA234 WPB	3.1	
3	2	Flange 2" WN #300 RF Sch.160	A105	3.1	
4	1	Seamless pipe 2" Sch.160	A106 GrB	3.1	
5	1	Seamless pipe 2" Sch.160	A106 GrB	3.1	
6	2	Pad by pipe 12" Sch.STD	A106 Gr.B	3.1	
7	1	Seamless elbow 2" 90° LR Sch.160	A234 WPB	3.1	
8	1	Coupling 1/2" NPT #6000	A105	3.1	
9	2	Plate 74.5x231 Thk.8	A516 70	3.1	
10	2	Plate 16x65 Thk.10	A516 70	3.1	
11	1	Nameplate support 156x241 Thk.3mm	A516 70	3.1	
12	2	Earthing Plate 55 x 40 Thk.3	A240 TP316L		

Note:
 1) Governing measurement S.I. unless otherwise specified;
 2) Flange bolt holes have to be straddled from main vessel center line in plan & vertical & horizontal centreline in elevation;
 3) Material: certification 3.1 EN 10204;
 4) All internal edge shall be rounded off;
 5) Nozzle flanges in accordance with ASME B16.5: 2013;
 6) Flange fittings in accordance with ASME B16.9: 2012;
 7) The flange dimensions are in accordance to ASME B16.5: 2013;
 8) All fillet welds not detailed on "WELDING MAP" or drawing shall have the weld; throated equal to 0,7 times the minimum thickness to be welded;
 9) All welds are continuous except where indicate;
 10) See document C220006CLC010 for vessel calculation.

ITEM	QTY	SERVICE	SIZE	PIPE O.D.	THK	RATING	FLANGE TYPE	FACE	O.D.	THK.	Tc
N3	1	DRAIN	1/2"	38.1	8.38	#6000	-	NPT-F	-	-	8.5 + 10
N2	1	AIR OUTLET	2"	60.3	8.74	#300	WN	RF	-	-	8.5 + 10
N1	1	AIR INLET	2"	60.3	8.74	#300	WN	RF	-	-	8.5 + 10

DATI DI PROGETTO / Design data			
FLUIDO	Nitrogen	COLLAUDO	Test
STATO FISICO DEL FLUIDO	Gas	NATIONAL BOARD REGISTRATION	NO
CODICE DI CALCOLO	ASME VIII Div. 1 Ed.2021	CANADIAN REGISTER NUMBER	NO
PRESSIONE DI ESERCIZIO	14.5 bara	SERVIZIO LETALE	NO
PRESSIONE DI PROGETTO	26 barg	RT examination	Spot (RT3)
PRESSIONE ESTERNA	NO	LICUIDI PENETRANTI	NO
PRESSIONE DI PROVA IDRAULICA	66.4 barg	ULTRASUONI	NO
TEMPERATURA DI ESERCIZIO	+134 °C	CONTROLLO MAGNETOSCOPICO	NO
TEMPERATURA DI PROGETTO	+170 °C	WELD TEST COUPON	NO
SOVRAMETALLO DI CORROSIONE	3 mm	PROCEDIMENTO DI SALDATURA	See doc: C220006WBK013
EFFICIENZA GIUNTI	0.85	FORMAZIONE FONDO	CAP
MAWP @ Design Temperature	33.46 barg @ +170 °C	PESO A VUOTO	116 kg
MDMT @ MAWP	0 °C @ 33.46 barg	PESO PIENO D'ACQUA	214 kg
TRATTAMENTO TERMICO	NO	DATI DEL VENTO	-
IMPACT TEST	NO	DATI SISMICI	-

Rev.	Descrizione / Description	Disegnato/Draw	Controllato/Checked	Approvato/Approved	Data/Date
01	Modified strenght lenght on cap	CM	MV	GL	30/03/2022
00	FIRST ISSUE	CM	MV	GL	16/03/2022

Oggetto/Object: N2 PULSATION DAMPER 1st STAGE DISCHARGE
 Scala/Scale: 1 : 5
 Comm. N°/Job No.: C220006
 Cliente/Customer: Airpack Nederland B.V.
 Ord. No.: 18498-VV-0901
 Dis. N°/Dwg No.: C220006DWG004
 Rev. 01

DESIGN CALCULATION

In Accordance with ASME Section VIII Division 1

ASME Code Version : 2019

Analysis Performed by : PPV-Engineering B.V.

Job File : P:\2_ENGINEERING\PROJ-2022\P22-115-AIRZI\01_PV E

Date of Analysis : Apr 19,2022 2:44pm

PV Elite 23 SP2, October 2021

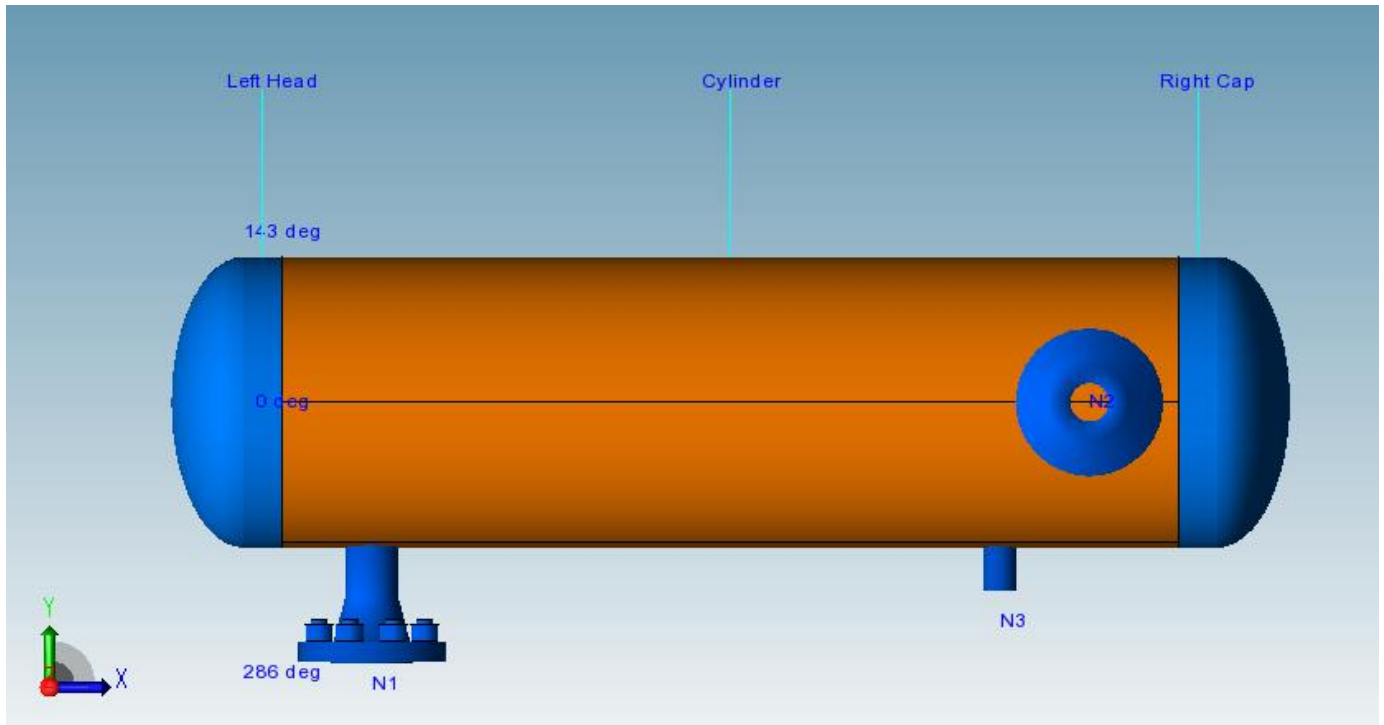

Table of Contents

Cover Sheet.....	2
Vessel Design Summary:.....	3
Nozzle Summary:	5
Nozzle Schedule:.....	6
Bill of Material:.....	6
Input Echo:.....	7
Internal Pressure Calculations:	11
Element and Detail Weights:.....	14
Nozzle Flange MAWP:.....	16
Nozzle Calcs.: N1	17
Nozzle Calcs.: N2	20
Nozzle Calcs.: N3	23

Vessel Design Summary:

ASME Code, Section VIII Division 1, 2019

Diameter Spec : 323.800 mm OD	
Vessel Design Length, Tangent to Tangent	1084.63 mm
Specified Datum Line Distance	42.31 mm
Internal Design Temperature	170 °C
Internal Design Pressure	2.600 N/mm ²
External Design Temperature	170 °C
Maximum Allowable Working Pressure	3.35 N/mm ²
Required Minimum Design Metal Temperature	-28.9 °C
Warmest Computed Minimum Design Metal Temperature	-46.0 °C
Wind Design Code	No Wind Loads
Earthquake Design Code	No Seismic

Materials of Construction:

Component Type	Material	Class	Thickness	UNS #	Normal ized	Impact Tested
Shell	SA-106 B	K03006	No	No
Head	SA-234 WPB	K03006	No	No
Nozzle	SA-106 B	K03006	No	No
Nozzle Flg	SA-105	K03504	No	No

Normalized is determined based on the UCS-66 material curve selection and Figure UCS-66.
 Impact Tested is based on material selection and material data properties.

Element Pressures and MAWP (N/mm² & mm):

Element Description or Type	Design Pressure + Stat. head	Ext. Press.	Element M.A.W.P	Total Corrosion Allowance	Str. Flg. Gov.	In Creep Range
Left Head	2.600	0.00	4.108	3.0000	Yes	No
Cylinder	2.600	0.00	3.350	3.0000	N/A	No
Right Cap	2.600	0.00	4.108	3.0000	Yes	No

Element Types and Properties:

Element Type	"To" Elev mm	Element Length mm	Nominal Thickness mm	Finished Thickness mm	Reqd Thk Internal mm	Reqd Thk External mm	Long Eff	Circ Eff
Ellipse	0.0	42.3	9.5	9.5	7.0	4.5	0.85	0.85
Cylinder	1000.0	1000.0	9.5	8.3	7.2	...	0.85	0.85
Ellipse	1042.3	42.3	9.5	9.5	7.0	4.5	0.85	0.85

PV Elite 23 SP2 Licensee: PPV-Engineering B.V.

FileName : 1-stage Discharge_LI4734 -----

Vessel Design Summary: Step: 15 2:44pm Apr 19,2022

Weights:

Fabricated - Bare W/O Removable Internals	107.7	kgm
Shop Test - Fabricated + Water (Full)	195.3	kgm
Shipping - Fab. + Rem. Intls.+ Shipping App.	107.7	kgm
Erected - Fab. + Rem. Intls.+ Insul. (etc)	107.7	kgm
Empty - Fab. + Intls. + Details + Wghts.	107.7	kgm
Operating - Empty + Operating Liquid (No CA)	107.7	kgm
Field Test - Empty Weight + Water (Full)	195.3	kgm

PV Elite is a trademark of Hexagon AB, 2021, All rights reserved.

Nozzle Calculation Summary:

Description	MAWP N/mm ²	Ext	MAPNC N/mm ²	UG-45	[tr] mm	Weld Path	Areas or Stresses
N1	3.35	OK	6.42	OK	No Calc[*]
N2	3.35	OK	6.42	OK	No Calc[*]
N3	3.35	OK	6.12	OK	No Calc[*]

Nozzle MAWP Summary:

Minimum MAWP Nozzles : 3.35 Nozzle : N3
 Minimum MAWP Shells/Flanges : 3.35 Element : Cylinder
 Minimum MAPnc Shells/Flanges : 0 Element : Cylinder

 Computed Vessel M.A.W.P. : 3.35 N/mm²

[*] - This was a small opening and the areas were not computed.

Note: MAWPs (Internal Case) shown above are at the High Point.

Check the Spatial Relationship between the Nozzles:

From Node	Nozzle Description	X Coordinate mm	Layout Angle deg	Dia. Limit mm
20	N1	142.315	270.000	97.700
20	N2	942.315	0.000	97.700
20	N3	842.315	270.000	54.672

The nozzle spacing is computed by the following:

= Sqrt(ll² + lc²) where

ll - Arc length along the inside vessel surface in the long. direction.

lc - Arc length along the inside vessel surface in the circ. direction

If any interferences/violations are found, they will be noted below.

No interference violations have been detected!

PV Elite is a trademark of Hexagon AB, 2021, All rights reserved.

Nozzle Schedule:

Description	Nominal or Actual Size	Schd or FVC Type	Flg Type	Nozzle O/Dia mm	Wall Thk mm	Reinforcing Diameter	Pad Thk mm	Cut Length mm	Flg Class
N3	38 mm	Actual	Non	38.1	8.4	5	...
N1	50 mm	160	WN	60.3	8.7	6	300
N2	50 mm	160	WN	60.3	8.7	6	300

General Notes for the above table:

The Cut Length is the Outside Projection + Inside Projection + Drop + In Plane Shell Thickness. This value does not include weld gaps, nor does it account for shrinkage.

In the case of Oblique Nozzles, the Outside Diameter must be increased. The Re-Pad WIDTH around the nozzle is calculated as follows:
 Width of Pad = (Pad Outside Dia. (per above) - Nozzle Outside Dia.)/2

For hub nozzles, the thickness and diameter shown are those of the smaller and thinner section.

Nozzle Material and Weld Fillet Leg Size Details (mm):

Description	Material	Shl Grve Weld	Noz Shl/Pad Weld	Pad OD Weld	Pad Grve Weld	Inside Weld
N3	SA-106 B	8.340	6.000
N1	SA-106 B	8.340	6.000
N2	SA-106 B	8.340	6.000

Note: The Outside projections below do not include the flange thickness.

Nozzle Miscellaneous Data:

Description	Elev/Distance From Datum mm	Layout Angle deg	Proj Outside mm	Proj Inside mm	Installed in Component
N3	800.000	270.0	47.62	0.00	Cylinder
N1	100.000	270.0	57.10	0.00	Cylinder
N2	900.000	0.0	57.10	0.00	Cylinder

PV Elite is a trademark of Hexagon AB, 2021, All rights reserved.

Bill of Materials:

QTY	DESCRIPTION	MATERIAL
2	ELLIPTICAL HEAD: 2.0 X 1, 9.5mm THK X 304.7mm ID X 42.3mm	SA-234 WPB
2	CYLINDRICAL SEGMENT 9.5mm THK X 383.3mm X 1000.0mm	SA-106 B
1	CYLINDRICAL SEGMENT 9.5mm THK X 198.3mm X 1000.0mm	SA-106 B
1	NAMEPLATE	...

PV Elite is a trademark of Hexagon AB, 2021, All rights reserved.

PV Elite Vessel Analysis Program: Input Data

Design Internal Pressure (for Hydrotest)	2.6	N/mm ²
Design Internal Temperature	170.0	°C
Projection of Nozzle from Vessel Top	0	mm
Projection of Nozzle from Vessel Bottom	0	mm
Minimum Design Metal Temperature	-28.9	°C
Type of Construction	Welded	
Special Service	None	
Degree of Radiography	RT-3	
Use Higher Longitudinal Stresses (Flag)	Y	
Select t for Internal Pressure (Flag)	N	
Select t for External Pressure (Flag)	N	
Select t for Axial Stress (Flag)	N	
Select Location for Stiff. Rings (Flag)	N	
Consider Vortex Shedding	N	
Perform a Corroded Hydrotest	N	

Shop Pressure Test:

Type of Pressure Test	not Specified
Pressure Test Position	Horizontal

Load Case 1	NP+EW+WI+FW+BW
Load Case 2	NP+EW+EE+FS+BS
Load Case 3	NP+OW+WI+FW+BW
Load Case 4	NP+OW+EQ+FS+BS
Load Case 5	NP+HW+HI
Load Case 6	NP+HW+HE
Load Case 7	IP+OW+WI+FW+BW
Load Case 8	IP+OW+EQ+FS+BS
Load Case 9	EP+OW+WI+FW+BW
Load Case 10	EP+OW+EQ+FS+BS
Load Case 11	HP+HW+HI
Load Case 12	HP+HW+HE
Load Case 13	IP+WE+EW
Load Case 14	IP+WF+CW
Load Case 15	IP+VO+OW
Load Case 16	IP+VE+EW
Load Case 17	NP+VO+OW
Load Case 18	FS+BS+IP+OW
Load Case 19	FS+BS+EP+OW

Wind Design Code No Wind Loads

Seismic Design Code No Seismic

Design Pressure + Static Head	Y
Consider MAP New and Cold in Noz. Design	N
Consider External Loads for Nozzle Des.	Y
Use ASME VIII-1 Appendix 1-9	N

Material Database Year Current w/Addenda or Code Year

Configuration Directives:

Do not use Nozzle MDMT Interpretation VIII-1 01-37	No
Use Table G instead of exact equation for "A"	Yes
Shell Head Joints are Tapered	Yes
Compute "K" in corroded condition	Yes
Use Code Case 2286	No
Use the MAWP to compute the MDMT	Yes
For thickness ratios <= 0.35, MDMT will be -155F (-104C)	Yes
For PWHT & P1 Materials the MDMT can be < -55F (-48C)	No

FileName : 1-stage Discharge_LI4734 -----

Input Echo: Step: 1 2:44pm Apr 19,2022

Using Metric Material Databases, ASME II D No
 Calculate B31.3 type stress for Nozzles with Loads Yes
 Reduce the MDMT due to lower membrane stress Yes
 Consider Longitudinal Stress in MDMT calcs. (Div. 1) Yes

Complete Listing of Vessel Elements and Details:

Element From Node 10
 Element To Node 20
 Element Type Elliptical
 Description Left Head
 Distance "FROM" to "TO" 42.315 mm
 Element Outside Diameter 323.8 mm
 Element Thickness 9.53 mm
 Internal Corrosion Allowance 3 mm
 Nominal Thickness 9.53 mm
 External Corrosion Allowance 0 mm
 Design Internal Pressure 2.6 N/mm²
 Design Temperature Internal Pressure 170 °C
 Design External Pressure 0 N/mm²
 Design Temperature External Pressure 170 °C
 Effective Diameter Multiplier 1.2
 Material Name SA-234 WPB
 Allowable Stress, Ambient 117.9 N/mm²
 Allowable Stress, Operating 117.9 N/mm²
 Allowable Stress, Hydrotest 153.3 N/mm²
 Material Density 7750.4 kg/m³
 P Number Thickness 30.988 mm
 Yield Stress, Operating 210.9 N/mm²
 UCS-66 Chart Curve Designation B
 External Pressure Chart Name CS-2
 UNS Number K03006
 Product Form Smls. & wld. fittings
 Efficiency, Longitudinal Seam 0.85
 Efficiency, Circumferential Seam 0.85
 Elliptical Head Factor 2.0
 Weld is pre-Heated No

 Element From Node 20
 Element To Node 30
 Element Type Cylinder
 Description Cylinder
 Distance "FROM" to "TO" 1000 mm
 Element Outside Diameter 323.8 mm
 Element Thickness 8.34 mm
 Internal Corrosion Allowance 3 mm
 Nominal Thickness 9.53 mm
 External Corrosion Allowance 0 mm
 Design Internal Pressure 2.6 N/mm²
 Design Temperature Internal Pressure 170 °C
 Design External Pressure 0 N/mm²
 Design Temperature External Pressure 170 °C
 Effective Diameter Multiplier 1.2
 Material Name SA-106 B
 Allowable Stress, Ambient 117.9 N/mm²
 Allowable Stress, Operating 117.9 N/mm²
 Allowable Stress, Hydrotest 153.3 N/mm²
 Material Density 7750.4 kg/m³
 P Number Thickness 30.988 mm
 Yield Stress, Operating 210.9 N/mm²
 UCS-66 Chart Curve Designation B
 External Pressure Chart Name CS-2

FileName : 1-stage Discharge_LI4734 -----

Input Echo: Step: 1 2:44pm Apr 19,2022

UNS Number	K03006
Product Form	Smls. pipe
Efficiency, Longitudinal Seam	0.85
Efficiency, Circumferential Seam	0.85
Weld is pre-Heated	No

Element From Node	20
Detail Type	Nozzle
Detail ID	N1
Dist. from "FROM" Node / Offset dist	100 mm
Nozzle Diameter	50 mm
Nozzle Schedule	160
Nozzle Class	300
Layout Angle	270.0
Blind Flange (Y/N)	N
Weight of Nozzle (Used if > 0)	0 N
Grade of Attached Flange	GR 1.1
Nozzle Matl	SA-106 B

Element From Node	20
Detail Type	Nozzle
Detail ID	N2
Dist. from "FROM" Node / Offset dist	900 mm
Nozzle Diameter	50 mm
Nozzle Schedule	160
Nozzle Class	300
Layout Angle	0.0
Blind Flange (Y/N)	N
Weight of Nozzle (Used if > 0)	0 N
Grade of Attached Flange	GR 1.1
Nozzle Matl	SA-106 B

Element From Node	20
Detail Type	Nozzle
Detail ID	N3
Dist. from "FROM" Node / Offset dist	800 mm
Nozzle Diameter	38.1 mm
Nozzle Schedule	None
Nozzle Class	None
Layout Angle	270.0
Blind Flange (Y/N)	N
Weight of Nozzle (Used if > 0)	0 N
Grade of Attached Flange	None
Nozzle Matl	SA-106 B

Element From Node	30
Element To Node	40
Element Type	Elliptical
Description	Right Cap
Distance "FROM" to "TO"	42.315 mm
Element Outside Diameter	323.8 mm
Element Thickness	9.53 mm
Internal Corrosion Allowance	3 mm
Nominal Thickness	9.53 mm
External Corrosion Allowance	0 mm
Design Internal Pressure	2.6 N/mm ²
Design Temperature Internal Pressure	170 °C
Design External Pressure	0 N/mm ²
Design Temperature External Pressure	170 °C
Effective Diameter Multiplier	1.2
Material Name	SA-234 WPB
Allowable Stress, Ambient	117.9 N/mm ²
Allowable Stress, Operating	117.9 N/mm ²

PV Elite 23 SP2 Licensee: PPV-Engineering B.V.

FileName : 1-stage Discharge_LI4734 -----

Input Echo: Step: 1 2:44pm Apr 19,2022

Allowable Stress, Hydrotest	153.3	N/mm ²
Material Density	7750.4	kg/m ³
P Number Thickness	30.988	mm
Yield Stress, Operating	210.9	N/mm ²
UCS-66 Chart Curve Designation	B	
External Pressure Chart Name	CS-2	
UNS Number	K03006	
Product Form	Smls. & wld. fittings	
Efficiency, Longitudinal Seam	0.85	
Efficiency, Circumferential Seam	0.85	
Elliptical Head Factor	2.0	
Weld is pre-Heated	No	

PV Elite is a trademark of Hexagon AB, 2021, All rights reserved.

Internal Pressure Results Summary:

Element Thickness, Pressure, Diameter and Allowable Stress :

From	To	Int. Press + Liq. Hd N/mm ²	Nominal Thickness mm	Total Corr Allowance mm	Element Diameter mm	Allowable Stress (SE) N/mm ²
Left Head		2.6	9.53	3	323.8	100.22
Cylinder		2.6	9.53	3	323.8	100.22
Right Cap		2.6	9.53	3	323.8	100.22

Element Required Thickness and MAWP :

From	To	Design Pressure N/mm ²	M.A.W.P. Corroded N/mm ²	M.A.P. New & Cold N/mm ²	Minimum Thickness mm	Required Thickness mm
Left Head		2.6	4.108	6.229	9.53	7.00438
Cylinder		2.6	3.35	5.271	8.34	7.15723
Right Cap		2.6	4.108	6.229	9.53	7.00438
Minimum			3.35	5.11		

Note : The M.A.P.(NC) is Governed by a Flange !

MAWP: 3.35 N/mm², limited by: Cylinder.

Elements Suitable for Design Internal Pressure.

Internal Pressure Calculation Results:

ASME Code, Section VIII Division 1, 2019

Elliptical Head From 10 To 20 SA-234 WPB , UCS-66 Crv. B at 170 °C

Left Head

Material UNS Number: K03006

Required Thickness due to Internal Pressure [tr]:

$$= (P \cdot Do \cdot K_{cor}) / (2 \cdot S \cdot E + 2 \cdot P \cdot (K_{cor} - 0.1)) \text{ per Appendix 1-4 (c)}$$

$$= (2.6 \cdot 323.8 \cdot 0.975) / (2 \cdot 117.9 \cdot 0.85 + 2 \cdot 2.6 \cdot (0.975 - 0.1))$$

$$= 4.0044 + 3.0000 = 7.0044 \text{ mm}$$

Max. Allowable Working Pressure at given Thickness, corroded [MAWP]:

$$= (2 \cdot S \cdot E \cdot t) / (K_{cor} \cdot Do - 2 \cdot t \cdot (K_{cor} - 0.1)) \text{ per Appendix 1-4 (c)}$$

$$= (2 \cdot 117.9 \cdot 0.85 \cdot 6.53) / (0.975 \cdot 323.8 - 2 \cdot 6.53 \cdot (0.975 - 0.1))$$

$$= 4.301 \text{ N/mm}^2$$

Maximum Allowable Pressure, New and Cold [MAPNC]:

$$= (2 \cdot S \cdot E \cdot t) / (K \cdot Do - 2 \cdot t \cdot (K - 0.1)) \text{ per Appendix 1-4 (c)}$$

$$= (2 \cdot 117.9 \cdot 0.85 \cdot 9.53) / (1 \cdot 323.8 - 2 \cdot 9.53 \cdot (1 - 0.1))$$

$$= 6.229 \text{ N/mm}^2$$

Actual stress at given pressure and thickness, corroded [Sact]:

$$= (P \cdot (K_{cor} \cdot Do - 2 \cdot t \cdot (K_{cor} - 0.1))) / (2 \cdot E \cdot t)$$

$$= (2.6 \cdot (0.975 \cdot 323.8 - 2 \cdot 6.53 \cdot (0.975 - 0.1))) / (2 \cdot 0.85 \cdot 6.53)$$

$$= 71.264 \text{ N/mm}^2$$

Straight Flange Required Thickness:

$$= (P \cdot Ro) / (S \cdot E + 0.4 \cdot P) + ca \text{ per Appendix 1-1 (a) (1)}$$

$$= (2.6 \cdot 161.9) / (117.9 \cdot 0.85 + 0.4 \cdot 2.6) + 3$$

FileName : 1-stage Discharge_LI4734 -----

Internal Pressure Calculations: Step: 3 2:44pm Apr 19,2022

$$= 7.157 \text{ mm}$$

Straight Flange Maximum Allowable Working Pressure:

$$= (S \cdot E \cdot t) / (R_o - 0.4 \cdot t) \text{ per Appendix 1-1 (a) (1)}$$

$$= (117.9 \cdot 0.85 \cdot 6.53) / (161.9 - 0.4 \cdot 6.53)$$

$$= 4.108 \text{ N/mm}^2$$

Factor K, corroded condition [Kcor]:

$$= (2 + (\text{Inside Diameter} / (2 \cdot \text{Inside Head Depth}))^2) / 6$$

$$= (2 + (310.7 / (2 \cdot 79.18))^2) / 6$$

$$= 0.974982$$

MDMT Calculations in the Knuckle Portion:

Govrn. thk, tg = 9.53, tr = 5.126, c = 3 mm, E* = 0.85
 Thickness Ratio = tr * (E*) / (tg - c) = 0.667, Temp. Reduction = 18 °C

Min Metal Temp. w/o impact per UCS-66, Curve B -29 °C
 Min Metal Temp. at Required thickness (UCS 66.1) -47 °C

MDMT Calculations in the Head Straight Flange:

Govrn. thk, tg = 9.53, tr = 5.34, c = 3 mm, E* = 0.85
 Thickness Ratio = tr * (E*) / (tg - c) = 0.695, Temp. Reduction = 17 °C

Min Metal Temp. w/o impact per UCS-66, Curve B -29 °C
 Min Metal Temp. at Required thickness (UCS 66.1) -46 °C

Cylindrical Shell From 20 To 30 SA-106 B, UCS-66 Crv. B at 170 °C

Cylinder

Longitudinal Joint: Seamless

Material UNS Number: K03006

Required Thickness due to Internal Pressure [tr]:

$$= (P \cdot R_o) / (S \cdot E + 0.4 \cdot P) \text{ per Appendix 1-1 (a) (1)}$$

$$= (2.6 \cdot 161.9) / (117.9 \cdot 0.85 + 0.4 \cdot 2.6)$$

$$= 4.1572 + 3.0000 = 7.1572 \text{ mm}$$

Max. Allowable Working Pressure at given Thickness, corroded [MAWP]:

$$= (S \cdot E \cdot t) / (R_o - 0.4 \cdot t) \text{ per Appendix 1-1 (a) (1)}$$

$$= (117.9 \cdot 0.85 \cdot 5.34) / (161.9 - 0.4 \cdot 5.34)$$

$$= 3.35 \text{ N/mm}^2$$

Maximum Allowable Pressure, New and Cold [MAPNC]:

$$= (S \cdot E \cdot t) / (R_o - 0.4 \cdot t) \text{ per Appendix 1-1 (a) (1)}$$

$$= (117.9 \cdot 0.85 \cdot 8.34) / (161.9 - 0.4 \cdot 8.34)$$

$$= 5.271 \text{ N/mm}^2$$

Actual stress at given pressure and thickness, corroded [Sact]:

$$= (P \cdot (R_o - 0.4 \cdot t)) / (E \cdot t)$$

$$= (2.6 \cdot ((161.9 - 0.4 \cdot 5.34)) / (0.85 \cdot 5.34))$$

$$= 91.515 \text{ N/mm}^2$$

Minimum Design Metal Temperature Results:

Govrn. thk, tg = 8.34, tr = 2.599, c = 3 mm, E* = 0.85
 Thickness Ratio = tr * (E*) / (tg - c) = 0.414, Temp. Reduction = 47 °C

Min Metal Temp. w/o impact per UCS-66, Curve B -29 °C
 Min Metal Temp. at Required thickness (UCS 66.1) -48 °C

Elliptical Head From 30 To 40 SA-234 WPB , UCS-66 Crv. B at 170 °C

Right Cap

Material UNS Number: K03006

Required Thickness due to Internal Pressure [tr]:

$$= (P \cdot Do \cdot K_{cor}) / (2 \cdot S \cdot E + 2 \cdot P \cdot (K_{cor} - 0.1)) \text{ per Appendix 1-4 (c)}$$

$$= (2.6 \cdot 323.8 \cdot 0.975) / (2 \cdot 117.9 \cdot 0.85 + 2 \cdot 2.6 \cdot (0.975 - 0.1))$$

$$= 4.0044 + 3.0000 = 7.0044 \text{ mm}$$

Max. Allowable Working Pressure at given Thickness, corroded [MAWP]:

$$= (2 \cdot S \cdot E \cdot t) / (K_{cor} \cdot Do - 2 \cdot t \cdot (K_{cor} - 0.1)) \text{ per Appendix 1-4 (c)}$$

$$= (2 \cdot 117.9 \cdot 0.85 \cdot 6.53) / (0.975 \cdot 323.8 - 2 \cdot 6.53 \cdot (0.975 - 0.1))$$

$$= 4.301 \text{ N/mm}^2$$

Maximum Allowable Pressure, New and Cold [MAPNC]:

$$= (2 \cdot S \cdot E \cdot t) / (K \cdot Do - 2 \cdot t \cdot (K - 0.1)) \text{ per Appendix 1-4 (c)}$$

$$= (2 \cdot 117.9 \cdot 0.85 \cdot 9.53) / (1 \cdot 323.8 - 2 \cdot 9.53 \cdot (1 - 0.1))$$

$$= 6.229 \text{ N/mm}^2$$

Actual stress at given pressure and thickness, corroded [Sact]:

$$= (P \cdot (K_{cor} \cdot Do - 2 \cdot t \cdot (K_{cor} - 0.1))) / (2 \cdot E \cdot t)$$

$$= (2.6 \cdot (0.975 \cdot 323.8 - 2 \cdot 6.53 \cdot (0.975 - 0.1))) / (2 \cdot 0.85 \cdot 6.53)$$

$$= 71.264 \text{ N/mm}^2$$

Straight Flange Required Thickness:

$$= (P \cdot Ro) / (S \cdot E + 0.4 \cdot P) + ca \text{ per Appendix 1-1 (a) (1)}$$

$$= (2.6 \cdot 161.9) / (117.9 \cdot 0.85 + 0.4 \cdot 2.6) + 3$$

$$= 7.157 \text{ mm}$$

Straight Flange Maximum Allowable Working Pressure:

$$= (S \cdot E \cdot t) / (Ro - 0.4 \cdot t) \text{ per Appendix 1-1 (a) (1)}$$

$$= (117.9 \cdot 0.85 \cdot 6.53) / (161.9 - 0.4 \cdot 6.53)$$

$$= 4.108 \text{ N/mm}^2$$

Factor K, corroded condition [Kcor]:

$$= (2 + (\text{Inside Diameter} / (2 \cdot \text{Inside Head Depth}))^2) / 6$$

$$= (2 + (310.7 / (2 \cdot 79.18))^2) / 6$$

$$= 0.974982$$

MDMT Calculations in the Knuckle Portion:

Govrn. thk, tg = 9.53, tr = 5.126, c = 3 mm, E* = 0.85
 Thickness Ratio = tr * (E*) / (tg - c) = 0.667, Temp. Reduction = 18 °C

Min Metal Temp. w/o impact per UCS-66, Curve B -29 °C
 Min Metal Temp. at Required thickness (UCS 66.1) -47 °C

MDMT Calculations in the Head Straight Flange:

Govrn. thk, tg = 9.53, tr = 5.34, c = 3 mm, E* = 0.85
 Thickness Ratio = tr * (E*) / (tg - c) = 0.695, Temp. Reduction = 17 °C

Min Metal Temp. w/o impact per UCS-66, Curve B -29 °C
 Min Metal Temp. at Required thickness (UCS 66.1) -46 °C

PV Elite is a trademark of Hexagon AB, 2021, All rights reserved.

Element and Detail Weights:

From	To	Element Metal Wgt. kgm	Element ID Volume m³	Corroded Metal Wgt. kgm	Corroded ID Volume m³	Extra due Misc %
10	20	11.8169	0.006792	8.09701	0.007138	...
20	30	73.4771	0.074094	50.8239	0.077017	...
30	40	11.8169	0.006792	8.09701	0.007138	...
Total		97	0.09	67	0.09	0

Weight of Details:

From	Type	Weight of Detail kgm	X Offset, Dtl. Cent. mm	Y Offset, Dtl. Cent. mm	Z Offset, Dtl. Cent. mm	Description
20	Noz1	5.12569	100	-183.723	...	N1
20	Noz1	5.12569	900	...	183.723	N2
20	Noz1	0.28886	800	-172.61	...	N3

Total Weight of Each Detail Type:

Nozzles	10.5
Sum of the Detail Weights	10.5 kgm

Weight Summation Results: (kgm)

	Fabricated	Shop Test	Shipping	Erected	Empty	Operating
Main Elements	97.1	97.1	97.1	97.1	97.1	97.1
Nozzles	10.5	10.5	10.5	10.5	10.5	10.5
Test Liquid	...	87.6
Totals	107.7	195.3	107.7	107.7	107.7	107.7

Weight Summary:

Fabricated Wt.	- Bare Weight without Removable Internals	107.7 kgm
Shop Test Wt.	- Fabricated Weight + Water (Full)	195.3 kgm
Shipping Wt.	- Fab. Weight + removable Intls.+ Shipping App.	107.7 kgm
Erected Wt.	- Fab. Wt + or - loose items (trays,platforms etc.)	107.7 kgm
Ope. Wt. no Liq	- Fab. Weight + Internals. + Details + Weights	107.7 kgm
Operating Wt.	- Empty Weight + Operating Liq. Uncorroded	107.7 kgm
Oper. Wt. + CA	- Corr Wt. + Operating Liquid	77.6 kgm
Field Test Wt.	- Empty Weight + Water (Full)	195.3 kgm

Note:

The Corroded Weight and thickness are used in the Horizontal Vessel Analysis (Ope Case) and Earthquake Load Calculations.

Outside Surface Areas of Elements:

From	To	Surface Area cm²
10	20	1566.97
20	30	10247.2
30	40	1566.97

PV Elite 23 SP2 Licensee: PPV-Engineering B.V.

FileName : 1-stage Discharge_LI4734 -----

Element and Detail Weights: Step: 5 2:44pm Apr 19,2022

Total 13381.184 cm²

PV Elite is a trademark of Hexagon AB, 2021, All rights reserved.

FileName : 1-stage Discharge_LI4734 -----

Nozzle Flange MAWP: Step: 6 2:44pm Apr 19,2022

Nozzle Flange MAWP Results: (N/mm² & °C)

Nozzle Description	Flange Rating		Design Temp	Class	Grade/Group	Equiv. Press	Max Pressure		
	Ope.	Ambient					UG-44(b)	50%	DNV
N1	4.46	5.11	170	300	GR 1.1
N2	4.46	5.11	170	300	GR 1.1
Min Rating	4.458	5.110 N/mm ² [for Core Elements]					0.000	0.000	0.000

Pressure Ratings are per ASME B16.5 2013 Metric Edition

PV Elite is a trademark of Hexagon AB, 2021, All rights reserved.

Input, Nozzle Desc: N1 From: 20

Pressure for Reinforcement Calculations	P	2.6000	N/mm ²
Temperature for Internal Pressure	Temp	170	°C
Parent Material		SA-106 B	
Parent Allowable Stress at Temperature	Sv	117.90	N/mm ²
Parent Allowable Stress At Ambient	Sva	117.90	N/mm ²
Inside Diameter of Cylindrical Shell	D	304.74	mm
Shell Finished (Minimum) Thickness	t	8.3400	mm
Shell Internal Corrosion Allowance	c	3.0000	mm
Shell External Corrosion Allowance	co	0.0000	mm
Distance from Bottom/Left Tangent		142.32	mm
User Entered Minimum Design Metal Temperature		-28.89	°C

Type of Element Connected to the Parent : Nozzle

Material		SA-106 B	
Material UNS Number		K03006	
Material Specification/Type		Smls. pipe	
Allowable Stress at Temperature	Sn	117.90	N/mm ²
Allowable Stress At Ambient	Sna	117.90	N/mm ²
Diameter Basis (for tr calc only)		Outside	
Layout Angle		270.00	deg
Diameter		50.0000	mm
Size and Thickness Basis		Nominal	
Nominal Thickness		160	
Flange Material		SA-105	
Flange Type		Weld Neck Flange	
Corrosion Allowance	can	3.0000	mm
Joint Efficiency of Shell Seam at Nozzle	E1	1.00	
Joint Efficiency of Nozzle Neck	En	1.00	
Outside Projection	ho	57.1000	mm
Weld leg size between Nozzle and Pad/Shell	Wo	6.0000	mm
Groove weld depth between Nozzle and Vessel	Wgnv	8.3400	mm
Flange Class		300	
Flange Grade		GR 1.1	

The Pressure Design option was Design Pressure + static head.

Nozzle Sketch (may not represent actual weld type/configuration)



Abutting/Set-on Nozzle No Pad

Reinforcement CALCULATION, Description: N1

ASME Code, Section VIII, Div. 1, 2019, UG-37 to UG-45

Actual Outside Diameter Used in Calculation 60.325 mm.
 Actual Thickness Used in Calculation 8.738 mm

Nozzle input data check completed without errors.

Reqd thk per UG-37(a) of Cylindrical Shell, tr [Int. Press]

$$= P \cdot R / (S_v \cdot E - 0.6 \cdot P) \text{ per UG-27 (c) (1)}$$

$$= 2.6 \cdot 155.4 / (117.9 \cdot 1 - 0.6 \cdot 2.6)$$

$$= 3.4723 \text{ mm}$$

Reqd thk per UG-37(a) of Nozzle Wall, trn [Int. Press]

$$= P \cdot R_o / (S_n \cdot E + 0.4 \cdot P) \text{ per Appendix 1-1 (a) (1)}$$

$$= 2.6 \cdot 30.16 / (117.9 \cdot 1 + 0.4 \cdot 2.6)$$

$$= 0.6593 \text{ mm}$$

UG-40, Limits of Reinforcement : [Internal Pressure]

Parallel to Vessel Wall (Diameter Limit) D1 97.6996 mm
 Parallel to Vessel Wall, opening length d 48.8498 mm
 Normal to Vessel Wall (Thickness Limit), no pad Tlnp 13.3500 mm

Note:

*Taking a UG-36(c)(3)(a) exemption for nozzle: N1.
 This calculation is valid for nozzles that meet all the requirements of paragraph UG-36. Please check the Code carefully, especially for nozzles that are not isolated or do not meet Code spacing requirements. To force the computation of areas for small nozzles go to Tools->Configuration and check the box to force the UG-37 small nozzle area calculation or force the Appendix 1-10 computation in Nozzle Design Options.*

UG-45 Minimum Nozzle Neck Thickness Requirement: [Int. Press.]

Wall Thickness for Internal/External pressures ta = 3.6593 mm
 Wall Thickness per UG16(b), tr16b = 4.5000 mm
 Wall Thickness, shell/head, internal pressure trb1 = 6.4723 mm
 Wall Thickness tb1 = max(trb1, tr16b) = 6.4723 mm
 Wall Thickness trb2 = max(trb2, tr16b) = 4.5000 mm
 Wall Thickness per table UG-45 tb3 = 6.4200 mm

Determine Nozzle Thickness candidate [tb]:

$$= \min[tb3, \max(tb1, tb2)]$$

$$= \min[6.42, \max(6.472, 4.5)]$$

$$= 6.4200 \text{ mm}$$

Minimum Wall Thickness of Nozzle Necks [tUG-45]:

$$= \max(ta, tb)$$

$$= \max(3.659, 6.42)$$

$$= 6.4200 \text{ mm}$$

Available Nozzle Neck Thickness = 0.875 * 8.738 = 7.645 mm --> OK

Nozzle Junction Minimum Design Metal Temperature (MDMT) Calculations:

Nozzle Neck to Flange Weld, min(Curve:B, Curve:A)

Govrn. thk, tg = 7.645, tr = 0.659, c = 3 mm, E* = 1
 Thickness Ratio = tr * (E*) / (tg - c) = 0.142, Temp. Reduction = 78 °C

Min Metal Temp. w/o impact per UCS-66, Curve A -8 °C

PV Elite 23 SP2 Licensee: PPV-Engineering B.V.

FileName : 1-stage Discharge_LI4734 -----

Nozzle Calcs.: N1

Noz1: 13 2:44pm Apr 19,2022

Min Metal Temp. at Required thickness (UCS 66.1) -104 °C

Nozzle-Shell/Head Weld (UCS-66(a)1(b)), Curve: B

Govrn. thk, tg = 7.645, tr = 0.659, c = 3 mm, E* = 1

Thickness Ratio = $tr * (E^*) / (tg - c) = 0.142$, Temp. Reduction = 78 °C

Min Metal Temp. w/o impact per UCS-66, Curve B -29 °C

Min Metal Temp. at Required thickness (UCS 66.1) -104 °C

Gov. MDMT of the nozzle to shell joint welded assembly : -104 °C

ANSI Flange MDMT including Temperature reduction per UCS-66.1:

Unadjusted MDMT of ASME B16.5/47 flanges per UCS-66(c) -18 °C

Flange MDMT with Temp reduction per UCS-66(b) (1) (-b) -48 °C

Where the Stress Reduction Ratio per UCS-66(b)(1)(-b) is :

Design Pressure/Ambient Rating = $2.60 / 5.11 = 0.509$

Weld Size Calculations, Description: N1

Intermediate Calc. for nozzle/shell Welds Tmin 5.7376 mm

Results Per UW-16.1:

	Required Thickness	Actual Thickness
Nozzle Weld	$4.0163 = 0.7 * t_{min}$	$4.2420 = 0.7 * W_o$ mm

Skipping the nozzle attachment weld strength calculations.

Per UW-15(b)(2) the nozzles exempted by UG-36(c)(3)(a)

(small nozzles) do not require a weld strength check.

Maximum Allowable Pressure for this Nozzle at this Location:

Converged Max. Allow. Pressure in Operating case 3.35 N/mm²

Note: The MAWP of this junction was limited by the parent Shell/Head.

The Drop for this Nozzle is : 3.0152 mm

The Cut Length for this Nozzle is, Drop + Ho + H + T : 68.4552 mm

Note: This nozzle or its diameter limit intersects weld seam # [3] on this element. The distance between the nozzle and seam is, 43.39 mm , while the distance from the center of the nozzle to the edge of the diameter limit is: 48.85 mm

PV Elite is a trademark of Hexagon AB, 2021, All rights reserved.

Input, Nozzle Desc: N2

From: 20

Pressure for Reinforcement Calculations	P	2.6000	N/mm ²
Temperature for Internal Pressure	Temp	170	°C
Parent Material		SA-106 B	
Parent Allowable Stress at Temperature	Sv	117.90	N/mm ²
Parent Allowable Stress At Ambient	Sva	117.90	N/mm ²
Inside Diameter of Cylindrical Shell	D	304.74	mm
Shell Finished (Minimum) Thickness	t	8.3400	mm
Shell Internal Corrosion Allowance	c	3.0000	mm
Shell External Corrosion Allowance	co	0.0000	mm
Distance from Bottom/Left Tangent		942.32	mm
User Entered Minimum Design Metal Temperature		-28.89	°C

Type of Element Connected to the Parent : Nozzle

Material		SA-106 B	
Material UNS Number		K03006	
Material Specification/Type		Smls. pipe	
Allowable Stress at Temperature	Sn	117.90	N/mm ²
Allowable Stress At Ambient	Sna	117.90	N/mm ²
Diameter Basis (for tr calc only)		Outside	
Layout Angle		0.00	deg
Diameter		50.0000	mm
Size and Thickness Basis		Nominal	
Nominal Thickness		160	
Flange Material		SA-105	
Flange Type		Weld Neck Flange	
Corrosion Allowance	can	3.0000	mm
Joint Efficiency of Shell Seam at Nozzle	E1	1.00	
Joint Efficiency of Nozzle Neck	En	1.00	
Outside Projection	ho	57.1000	mm
Weld leg size between Nozzle and Pad/Shell	Wo	6.0000	mm
Groove weld depth between Nozzle and Vessel	Wgnv	8.3400	mm
Flange Class		300	
Flange Grade		GR 1.1	

The Pressure Design option was Design Pressure + static head.

Nozzle Sketch (may not represent actual weld type/configuration)

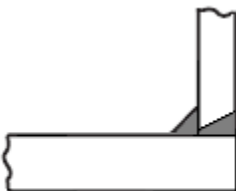

Abutting/Set-on Nozzle No Pad

Reinforcement CALCULATION, Description: N2

ASME Code, Section VIII, Div. 1, 2019, UG-37 to UG-45

Actual Outside Diameter Used in Calculation 60.325 mm.
 Actual Thickness Used in Calculation 8.738 mm

Nozzle input data check completed without errors.

Reqd thk per UG-37(a) of Cylindrical Shell, tr [Int. Press]

$$= P \cdot R / (S_v \cdot E - 0.6 \cdot P) \text{ per UG-27 (c) (1)}$$

$$= 2.6 \cdot 155.4 / (117.9 \cdot 1 - 0.6 \cdot 2.6)$$

$$= 3.4723 \text{ mm}$$

Reqd thk per UG-37(a) of Nozzle Wall, trn [Int. Press]

$$= P \cdot R_o / (S_n \cdot E + 0.4 \cdot P) \text{ per Appendix 1-1 (a) (1)}$$

$$= 2.6 \cdot 30.16 / (117.9 \cdot 1 + 0.4 \cdot 2.6)$$

$$= 0.6593 \text{ mm}$$

UG-40, Limits of Reinforcement : [Internal Pressure]

Parallel to Vessel Wall (Diameter Limit)	D1	97.6996	mm
Parallel to Vessel Wall, opening length	d	48.8498	mm
Normal to Vessel Wall (Thickness Limit), no pad	Tlnp	13.3500	mm

Note:

*Taking a UG-36(c)(3)(a) exemption for nozzle: N2.
 This calculation is valid for nozzles that meet all the requirements of paragraph UG-36. Please check the Code carefully, especially for nozzles that are not isolated or do not meet Code spacing requirements. To force the computation of areas for small nozzles go to Tools->Configuration and check the box to force the UG-37 small nozzle area calculation or force the Appendix 1-10 computation in Nozzle Design Options.*

UG-45 Minimum Nozzle Neck Thickness Requirement: [Int. Press.]

Wall Thickness for Internal/External pressures	ta	= 3.6593	mm
Wall Thickness per UG16(b),	tr16b	= 4.5000	mm
Wall Thickness, shell/head, internal pressure	trb1	= 6.4723	mm
Wall Thickness	tb1 = max(trb1, tr16b)	= 6.4723	mm
Wall Thickness	tb2 = max(trb2, tr16b)	= 4.5000	mm
Wall Thickness per table UG-45	tb3	= 6.4200	mm

Determine Nozzle Thickness candidate [tb]:

$$= \min[tb3, \max(tb1, tb2)]$$

$$= \min[6.42, \max(6.472, 4.5)]$$

$$= 6.4200 \text{ mm}$$

Minimum Wall Thickness of Nozzle Necks [tUG-45]:

$$= \max(ta, tb)$$

$$= \max(3.659, 6.42)$$

$$= 6.4200 \text{ mm}$$

Available Nozzle Neck Thickness = 0.875 * 8.738 = 7.645 mm --> OK

Nozzle Junction Minimum Design Metal Temperature (MDMT) Calculations:

Nozzle Neck to Flange Weld, min(Curve:B, Curve:A)

Govrn. thk, tg = 7.645, tr = 0.659, c = 3 mm, E* = 1
 Thickness Ratio = $tr \cdot (E^*) / (tg - c) = 0.142$, Temp. Reduction = 78 °C

Min Metal Temp. w/o impact per UCS-66, Curve A -8 °C
 Min Metal Temp. at Required thickness (UCS 66.1) -104 °C

Nozzle-Shell/Head Weld (UCS-66(a)1(b)), Curve: B

Govrn. thk, tg = 7.645, tr = 0.659, c = 3 mm, E* = 1
 Thickness Ratio = $tr \cdot (E^*) / (tg - c) = 0.142$, Temp. Reduction = 78 °C

Min Metal Temp. w/o impact per UCS-66, Curve B -29 °C
 Min Metal Temp. at Required thickness (UCS 66.1) -104 °C

Gov. MDMT of the nozzle to shell joint welded assembly : -104 °C

ANSI Flange MDMT including Temperature reduction per UCS-66.1:

Unadjusted MDMT of ASME B16.5/47 flanges per UCS-66(c) -18 °C
 Flange MDMT with Temp reduction per UCS-66(b) (1) (-b) -48 °C

Where the Stress Reduction Ratio per UCS-66(b)(1)(-b) is :
 Design Pressure/Ambient Rating = $2.60 / 5.11 = 0.509$

Weld Size Calculations, Description: N2

Intermediate Calc. for nozzle/shell Welds Tmin 5.7376 mm

Results Per UW-16.1:

	Required Thickness	Actual Thickness
Nozzle Weld	$4.0163 = 0.7 \cdot t_{min}$	$4.2420 = 0.7 \cdot W_o$ mm

Skipping the nozzle attachment weld strength calculations.
 Per UW-15(b)(2) the nozzles exempted by UG-36(c)(3)(a)
 (small nozzles) do not require a weld strength check.

Maximum Allowable Pressure for this Nozzle at this Location:

Converged Max. Allow. Pressure in Operating case 3.35 N/mm²

Note: The MAWP of this junction was limited by the parent Shell/Head.

The Drop for this Nozzle is : 3.0152 mm
 The Cut Length for this Nozzle is, Drop + Ho + H + T : 68.4552 mm

Note: This nozzle or its diameter limit intersects weld seam # [1] on this element. The distance between the nozzle and seam is, 0.00 mm , while the distance from the center of the nozzle to the edge of the diameter limit is: 48.85 mm

PV Elite is a trademark of Hexagon AB, 2021, All rights reserved.

Input, Nozzle Desc: N3

From: 20

Pressure for Reinforcement Calculations	P	2.6000	N/mm ²
Temperature for Internal Pressure	Temp	170	°C
Parent Material		SA-106 B	
Parent Allowable Stress at Temperature	Sv	117.90	N/mm ²
Parent Allowable Stress At Ambient	Sva	117.90	N/mm ²
Inside Diameter of Cylindrical Shell	D	304.74	mm
Shell Finished (Minimum) Thickness	t	8.3400	mm
Shell Internal Corrosion Allowance	c	3.0000	mm
Shell External Corrosion Allowance	co	0.0000	mm
Distance from Bottom/Left Tangent		842.32	mm
User Entered Minimum Design Metal Temperature		-28.89	°C

Type of Element Connected to the Parent : Nozzle

Material		SA-106 B	
Material UNS Number		K03006	
Material Specification/Type		Smls. pipe	
Allowable Stress at Temperature	Sn	117.90	N/mm ²
Allowable Stress At Ambient	Sna	117.90	N/mm ²
Diameter Basis (for tr calc only)		Outside	
Layout Angle		270.00	deg
Diameter		38.1000	mm
Size and Thickness Basis		Actual	
Actual Thickness	tn	8.3820	mm
Corrosion Allowance	can	3.0000	mm
Joint Efficiency of Shell Seam at Nozzle	E1	1.00	
Joint Efficiency of Nozzle Neck	En	1.00	
Outside Projection	ho	47.6250	mm
Weld leg size between Nozzle and Pad/Shell	Wo	6.0000	mm
Groove weld depth between Nozzle and Vessel	Wgnv	8.3400	mm

The Pressure Design option was Design Pressure + static head.

Nozzle Sketch (may not represent actual weld type/configuration)



Abutting/Set-on Nozzle No Pad

Reinforcement CALCULATION, Description: N3

ASME Code, Section VIII, Div. 1, 2019, UG-37 to UG-45

Actual Outside Diameter Used in Calculation 38.100 mm.
 Actual Thickness Used in Calculation 8.382 mm

Nozzle input data check completed without errors.

Reqd thk per UG-37(a) of Cylindrical Shell, tr [Int. Press]

$$= P \cdot R / (S_v \cdot E - 0.6 \cdot P) \text{ per UG-27 (c) (1)}$$

$$= 2.6 \cdot 155.4 / (117.9 \cdot 1 - 0.6 \cdot 2.6)$$

$$= 3.4723 \text{ mm}$$

Reqd thk per UG-37(a) of Nozzle Wall, trn [Int. Press]

$$= P \cdot R_o / (S_n \cdot E + 0.4 \cdot P) \text{ per Appendix 1-1 (a) (1)}$$

$$= 2.6 \cdot 19.05 / (117.9 \cdot 1 + 0.4 \cdot 2.6)$$

$$= 0.4164 \text{ mm}$$

UG-40, Limits of Reinforcement : [Internal Pressure]

Parallel to Vessel Wall (Diameter Limit)	Dl	54.6720	mm
Parallel to Vessel Wall, opening length	d	27.3360	mm
Normal to Vessel Wall (Thickness Limit), no pad	Tlnp	13.3500	mm

Note:

*Taking a UG-36(c)(3)(a) exemption for nozzle: N3.
 This calculation is valid for nozzles that meet all the requirements of paragraph UG-36. Please check the Code carefully, especially for nozzles that are not isolated or do not meet Code spacing requirements. To force the computation of areas for small nozzles go to Tools->Configuration and check the box to force the UG-37 small nozzle area calculation or force the Appendix 1-10 computation in Nozzle Design Options.*

UG-45 Minimum Nozzle Neck Thickness Requirement: [Int. Press.]

Wall Thickness for Internal/External pressures	ta	= 3.4164	mm
Wall Thickness per UG16(b),	tr16b	= 4.5000	mm
Wall Thickness, shell/head, internal pressure	trb1	= 6.4723	mm
Wall Thickness	tb1 = max(trb1, tr16b)	= 6.4723	mm
Wall Thickness	tb2 = max(trb2, tr16b)	= 4.5000	mm
Wall Thickness per table UG-45	tb3	= 6.1200	mm

Determine Nozzle Thickness candidate [tb]:

$$= \min[tb3, \max(tb1, tb2)]$$

$$= \min[6.12, \max(6.472, 4.5)]$$

$$= 6.1200 \text{ mm}$$

Minimum Wall Thickness of Nozzle Necks [tUG-45]:

$$= \max(ta, tb)$$

$$= \max(3.416, 6.12)$$

$$= 6.1200 \text{ mm}$$

Available Nozzle Neck Thickness = 8.3820 mm --> OK

Nozzle Junction Minimum Design Metal Temperature (MDMT) Calculations:

Nozzle-Shell/Head Weld (UCS-66(a)1(b)), Curve: B

Govrn. thk, tg = 8.34, tr = 3.472, c = 3 mm, E* = 1
Thickness Ratio = $tr * (E^*) / (tg - c) = 0.65$, Temp. Reduction = 19 °C

Min Metal Temp. w/o impact per UCS-66, Curve B -29 °C
Min Metal Temp. at Required thickness (UCS 66.1) -48 °C
Gov. MDMT of the nozzle to shell joint welded assembly : -48 °C

Weld Size Calculations, Description: N3

Intermediate Calc. for nozzle/shell Welds Tmin 5.3820 mm

Results Per UW-16.1:

	Required Thickness	Actual Thickness
Nozzle Weld	$3.7674 = 0.7 * t_{min}$	$4.2420 = 0.7 * W_o$ mm

Skipping the nozzle attachment weld strength calculations.
Per UW-15(b)(2) the nozzles exempted by UG-36(c)(3)(a)
(small nozzles) do not require a weld strength check.

Maximum Allowable Pressure for this Nozzle at this Location:

Converged Max. Allow. Pressure in Operating case 3.35 N/mm²

Note: The MAWP of this junction was limited by the parent Shell/Head.

The Drop for this Nozzle is : 1.1956 mm
The Cut Length for this Nozzle is, Drop + Ho + H + T : 57.1605 mm

PV Elite is a trademark of Hexagon AB, 2021, All rights reserved.

Report – 2nd-stage Discharge_LI4736

PV-Elite Calculation Summary

Client: Airpack Nederland BV.
Client location: Zierikzee
Ref number client: 17811-OO-0702(KP)

PPV Engineering

Author: H.Hoezen
- Telephone: +31 (0)594 581010
- E-mail: h.hoezen@ppv-engineering.nl

April 19, 2022
Order number: P22-115-01
Document number: 22-11501-C03
Revision: 0

Supports detail

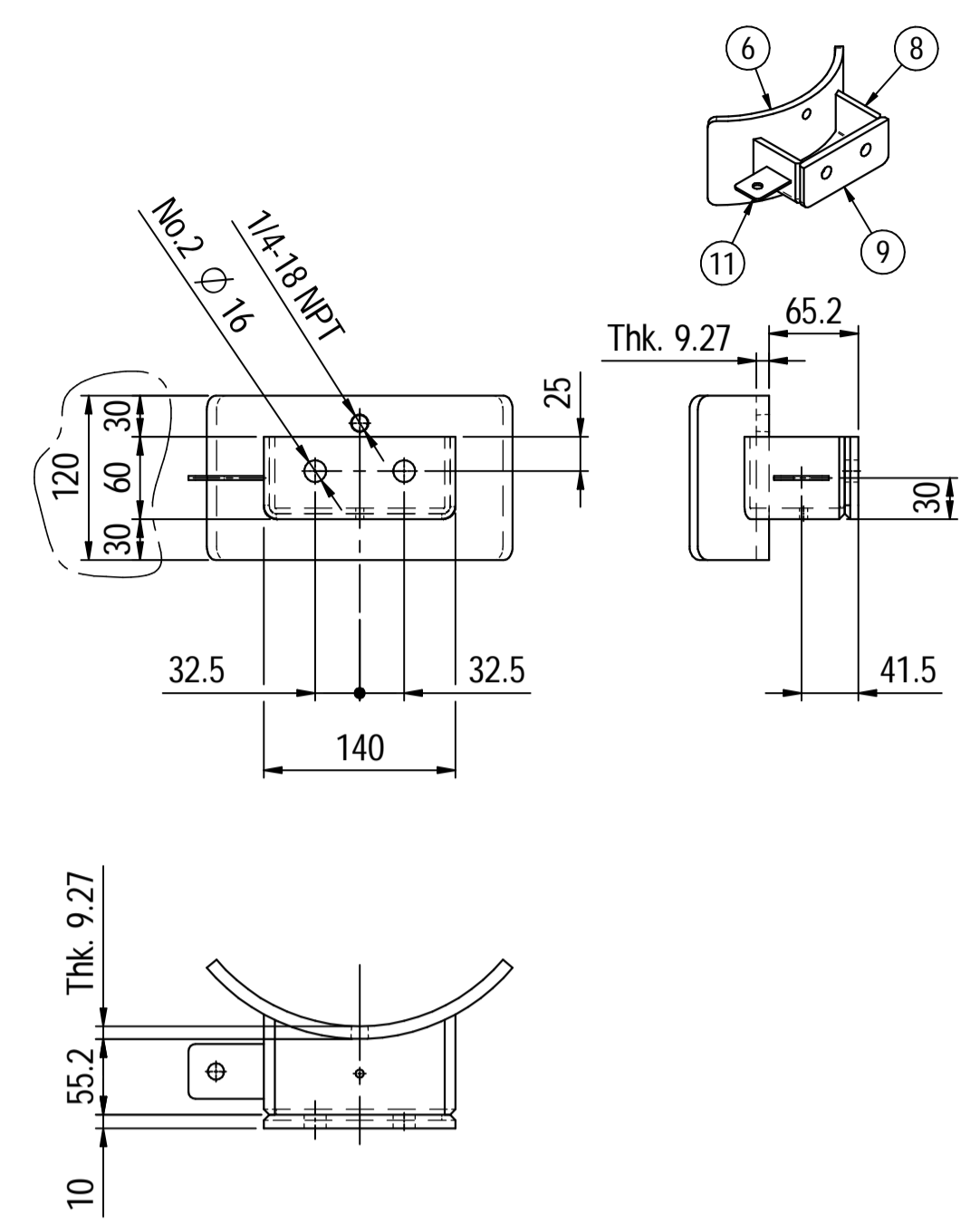

Nameplate detail

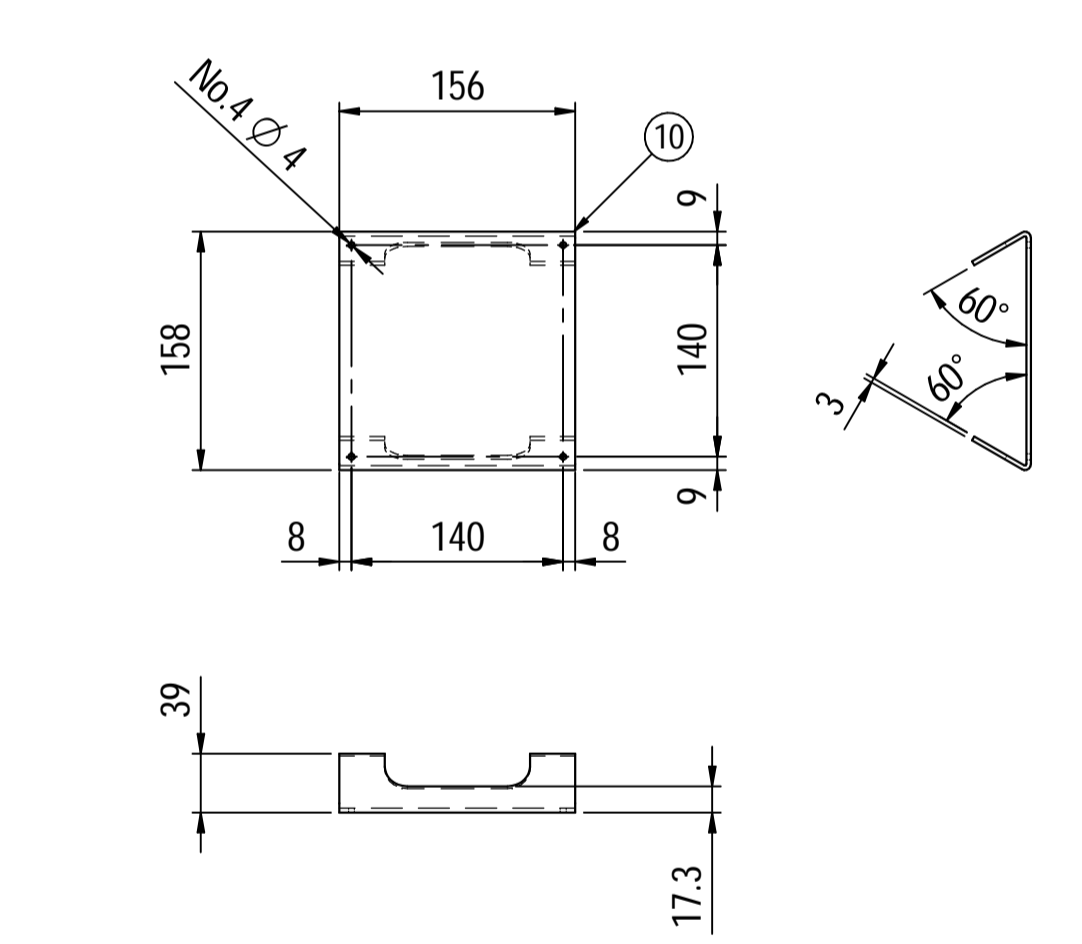

Nameplate detail scale 1:2

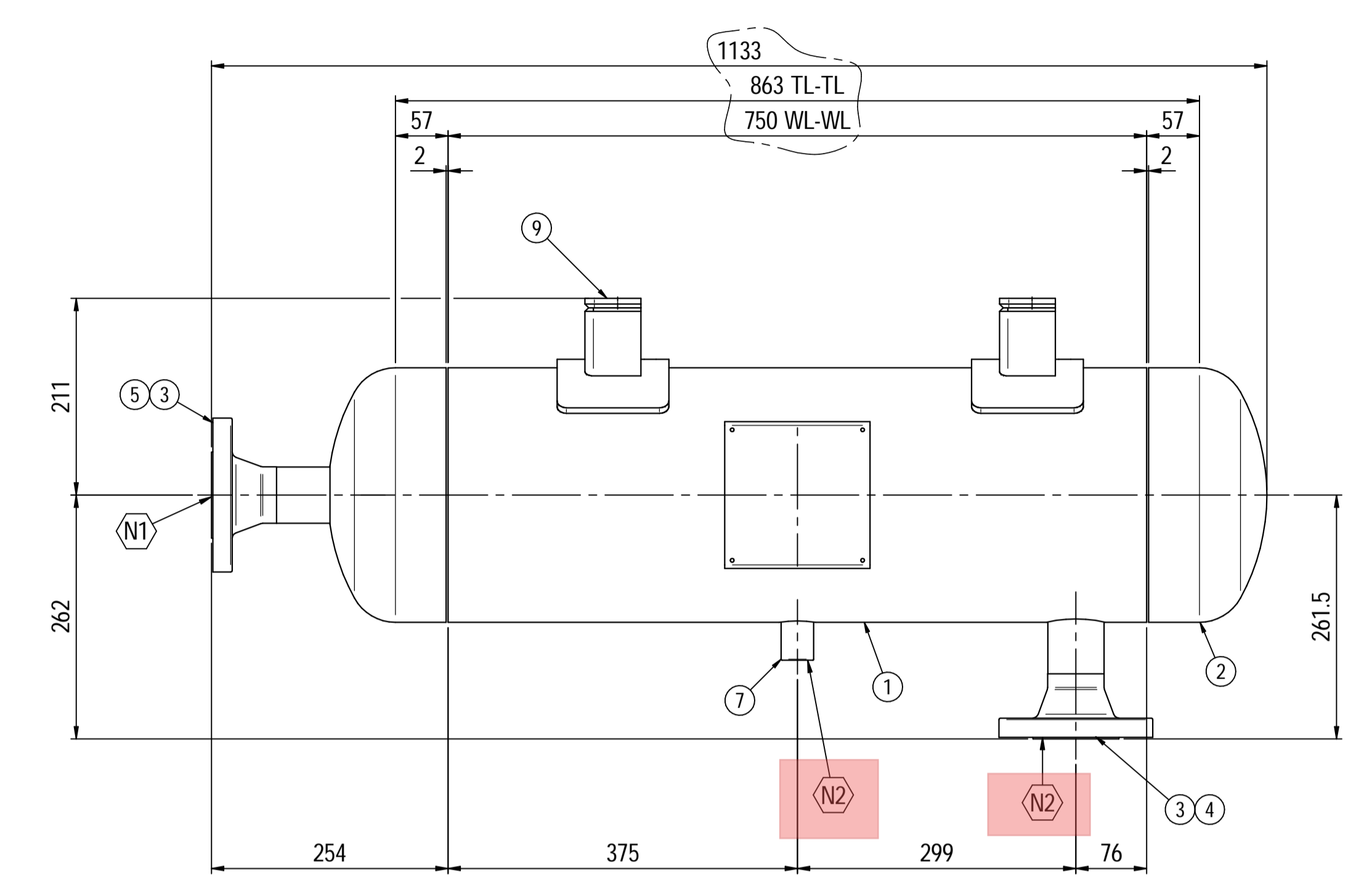
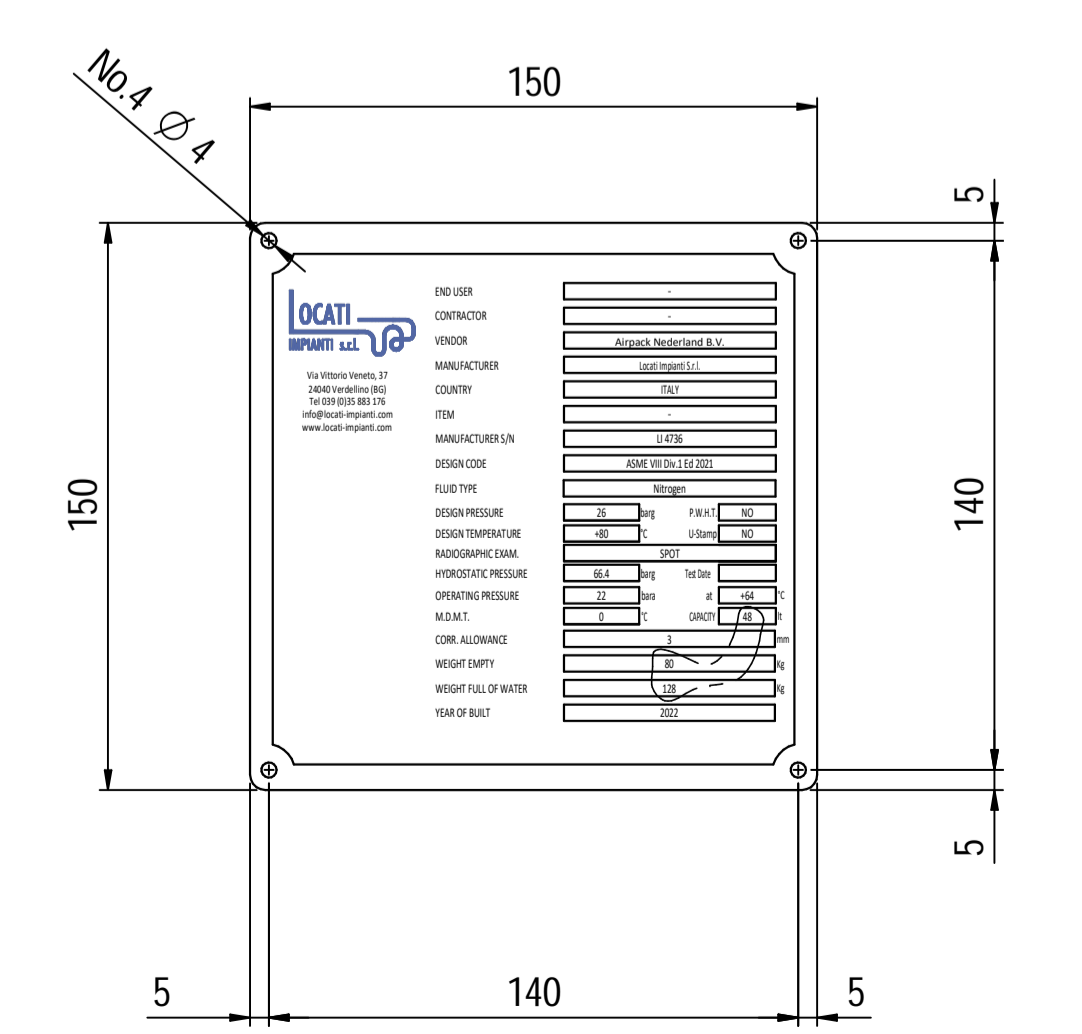

ELEVATION VIEW

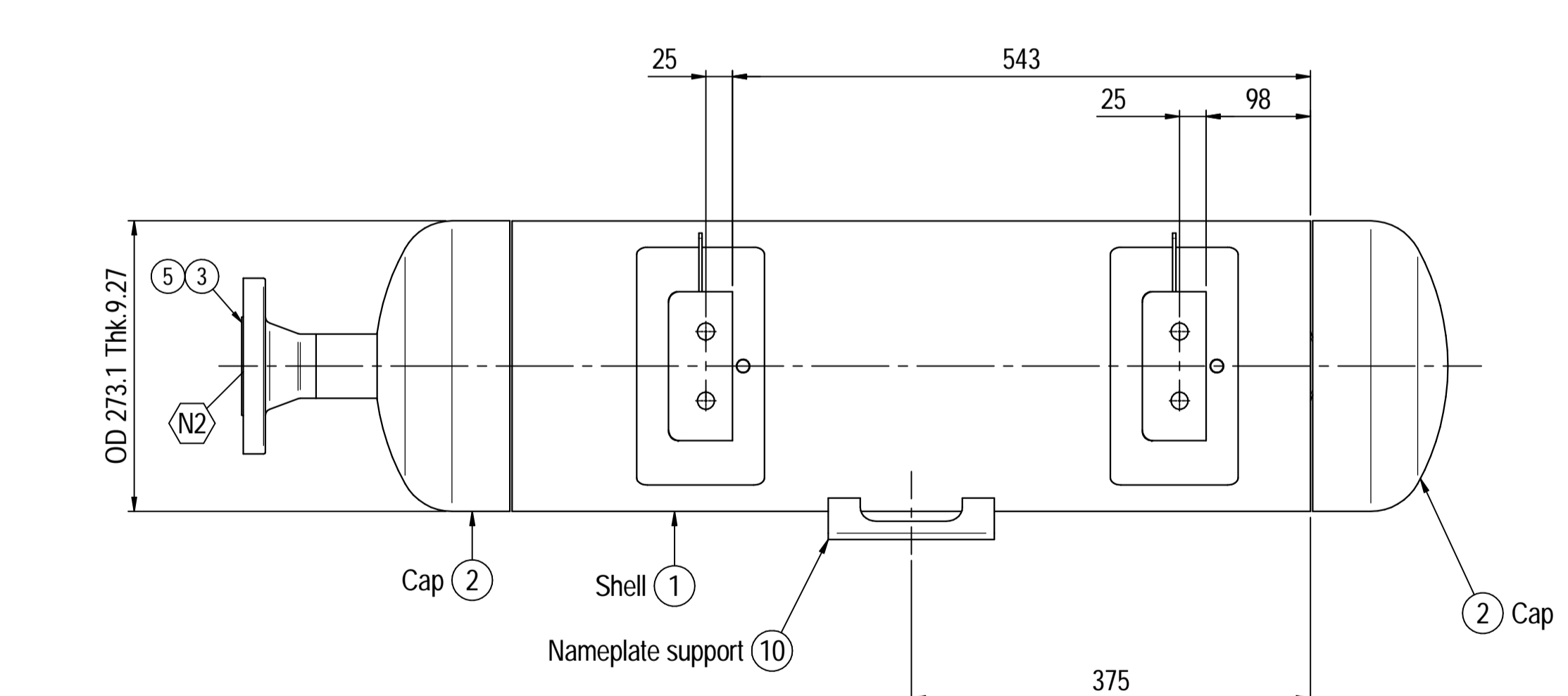

PLAN VIEW

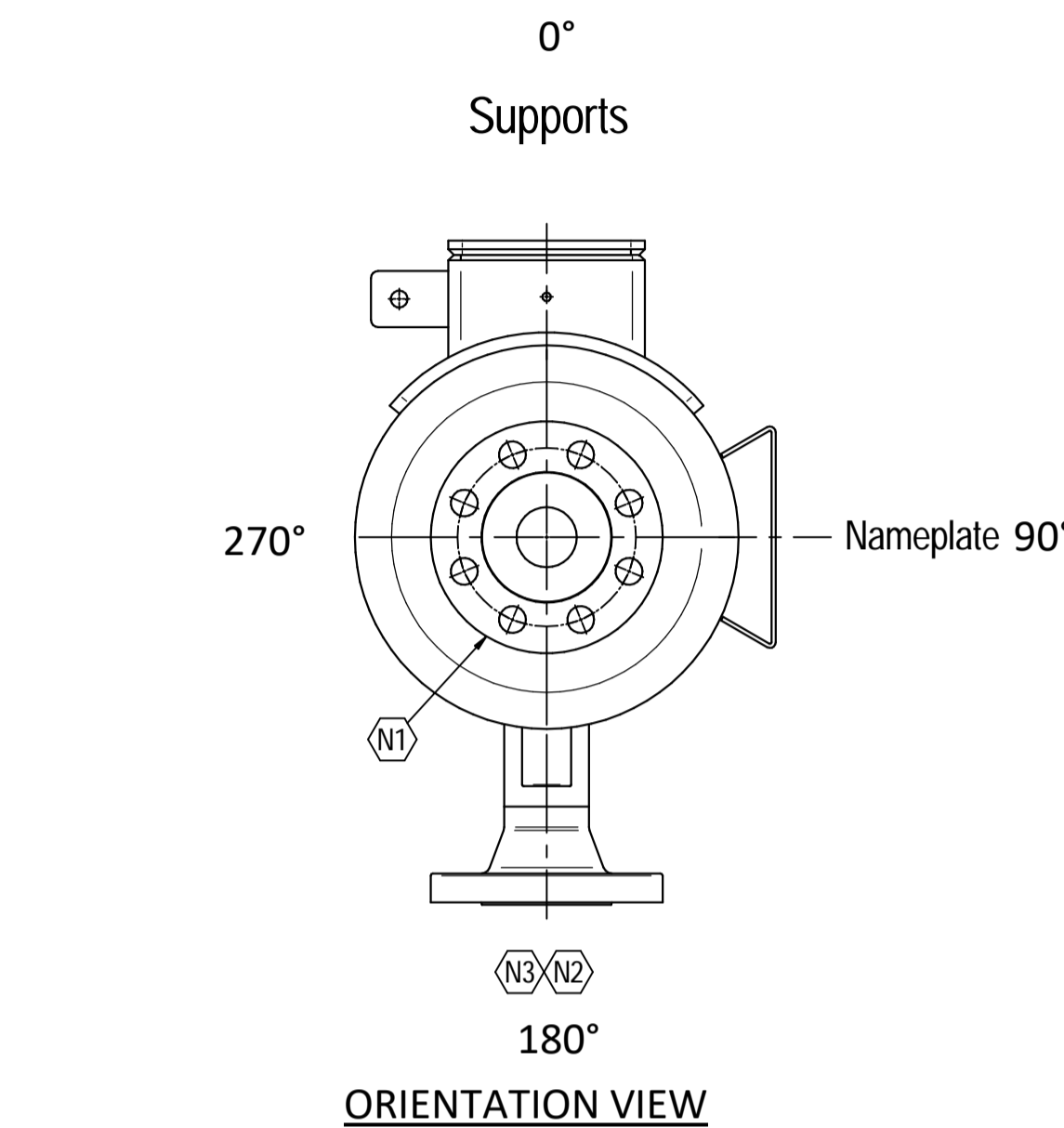

ORIENTATION VIEW

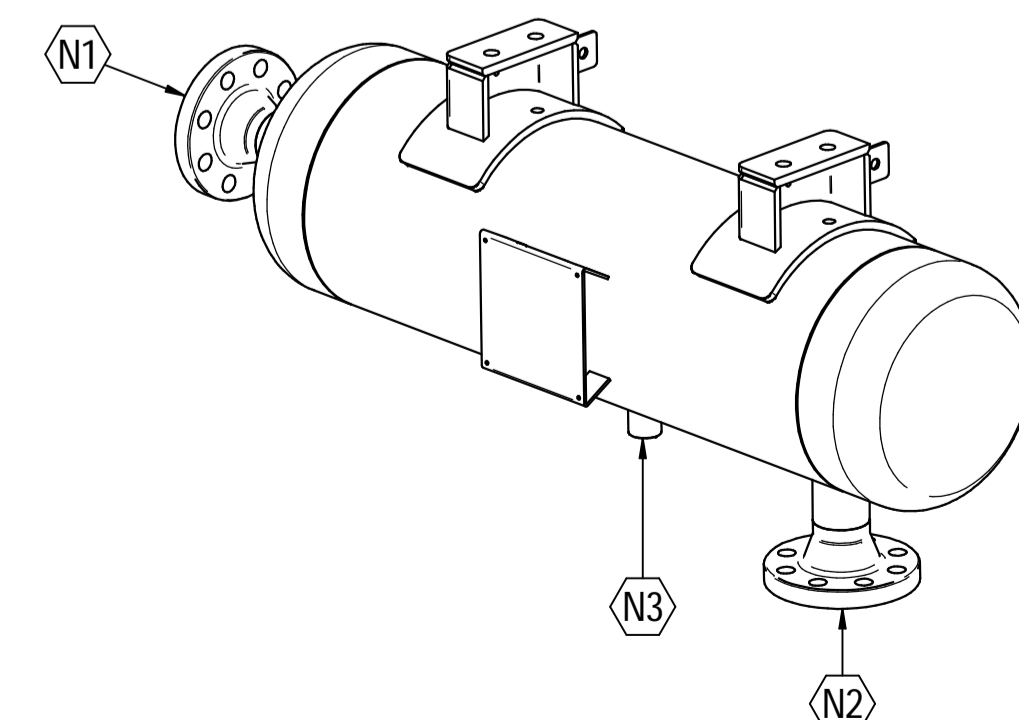

ISOMETRIC VIEW scale 1:8

Material List					
Pos.	Q.ty	Description	Mat.	Cert.	
1	1	Shell by seamless pipe 10" Sch. STD (L=750)	SA106 Gr.B	3.1	
2	2	Cap 10" Sch40	A234 WPB	3.1	
3	2	Flange 2" WN #300 RF Sch.160	A105	3.1	
4	1	Seamless pipe 2" Sch160 L=68	A106 GrB	3.1	
5	1	Seamless pipe 2" Sch160 L=65	A106 GrB	3.1	
6	2	Pad by pipe 10" Sch. STD	A106 Gr.B	3.1	
7	1	Coupling 1/2" NPT #6000	A105	3.1	
8	2	Plate 74.5x231 Thk.8	A516 70	3.1	
9	2	Plate 16x65 Thk.10	A516 70	3.1	
10	1	Nameplate support 234 x 156 thk3mm	S275 JR	3.1	
11	2	Earthing Plate 55 x 40 Thk.3	A240 TP316L	3.1	

Note:
 1) Governing measurement S.I. unless otherwise specified;
 2) Flange bolt holes have to be straddled from main vessel center line in plan & vertical & horizontal centreline in elevation;
 3) Material: certification 3.1 EN 10204;
 4) All internal edge shall be rounded off;
 5) Nozzle flanges in accordance with ASME B16.5: 2013;
 6) Flange fittings in accordance with ASME B16.9: 2012;
 7) The flange dimensions are in accordance with ASME B16.5: 2013;
 8) All fillet welds not detailed on "WELDING MAP" or drawing shall have the weld; throated equal to 0,7 times the minimum thickness to be welded;
 9) All welds are continuous except where indicate;
 10) See document C220006CLC012 for vessel calculation.

ITEM	QTY	SERVICE	SIZE	O.D.	THK	RATING	TYPE	FACE	O.D.	THK.	Tc
N3	1	DRAIN	1/2"	38.1	8.38	#6000	-	NPT-F	-	-	8.5 + 10
N2	1	AIR OUTLET	2"	60.3	8.74	#300	WN	RF	-	-	8.5 + 10
N1	1	AIR INLET	2"	60.3	8.74	#300	WN	RF	-	-	8.5 + 10

DATI DI PROGETTO / Design data			
FLUIDO	Nitrogen	COLLAUDO	Test
STATO FISICO DEL FLUIDO	Gas	NATIONAL BOARD REGISTRATION	NO
STATO FISICO DEL FLUIDO	Gas	CANADIAN REGISTER NUMBER	NO
CODICE DI CALCOLO	ASME VIII Div. 1 Ed.2021	SERVIZIO LETALE	NO
PRESSIONE DI ESERCIZIO	23 bara	RT examination	Spot (RT3)
PRESSIONE DI PROGETTO	26 barg	LICUIDI PENETRANTI	NO
PRESSIONE DI PROGETTO	26 barg	Dye penetrant extension	NO
PRESSIONE ESTERNA	NO	ULTRASUONI	NO
PRESSIONE ESTERNA	NO	Ultrasonic extension	NO
PRESSIONE DI PROVA IDRAULICA	66.4 barg	CONTROLLO MAGNETOSCOPICO	NO
PRESSIONE DI PROVA IDRAULICA	66.4 barg	Magnetic particle examination	NO
TEMPERATURA DI ESERCIZIO	+64 °C	TALONE DI SALDATURA	NO
TEMPERATURA DI ESERCIZIO	+64 °C	Weld tests coupon	NO
TEMPERATURA DI PROGETTO	+80 °C	PROCEDIMENTO DI SALDATURA	See doc: C220006WBK013
TEMPERATURA DI PROGETTO	+80 °C	Welding procedure	See doc: C220006WBK013
SOVRAMETALLO DI CORROSIONE	3 mm	TIPO DI FONDO	CAP
SOVRAMETALLO DI CORROSIONE	3 mm	Head type	CAP
CAPACITA'	48 l	FORMAZIONE FONDO	HOT
CAPACITA'	48 l	Head form	HOT
EFFICIENZA GIUNTI	0.85	PESO A VUOTO	80 kg
EFFICIENZA GIUNTI	0.85	Empty weight	80 kg
MAWP @ Design Temperature	38.12 barg @ +80 °C	PESO PIENO D'ACQUA	128 kg
MAWP @ Design Temperature	38.12 barg @ +80 °C	Full water weight	128 kg
MAWP(EXT)	NO	DATI DEL VENTO	-
MAWP(EXT)	NO	Wind data	-
MDMT @ MAWP	0 °C @ 38.12 barg	DATI SISMICI	-
MDMT @ MAWP	0 °C @ 38.12 barg	Seismological data	-
TRATTAMENTO TERMICO	NO		
TRATTAMENTO TERMICO	NO		
P.W.H.T.			
P.W.H.T.			
IMPACT TEST	NO		
IMPACT TEST	NO		
Exemption			
Exemption			

Rev.	Descrizione / Description	Disegnato/Draw	Controllato/Checked	Approvato/Approved	Data/Date
01	Modified shell length	CM	MV	GL	30/03/2022
00	FIRST ISSUE	CM	MV	GL	16/03/2022

Oggetto/Object N2 PULSATION DAMPER 2nd STAGE DISCHARGE					
Scala/Scale	1 : 5	Formato/Size	A1		
Comm. N°/Job No.	C220006	Foglio/Sheet	1 - 1		
Cliente/Customer	Airpack Nederland B.V.				
Ord. No.	18498-VV-0901				
Dis. N°/Dwg No.	C220006DWG006				Rev. 01

DESIGN CALCULATION

In Accordance with ASME Section VIII Division 1

ASME Code Version : 2019

Analysis Performed by : PPV-Engineering B.V.

Job File : P:\2_ENGINEERING\PROJ-2022\P22-115-AIRZI\01_PV E

Date of Analysis : Apr 13,2022 11:08am

PV Elite 23 SP2, October 2021

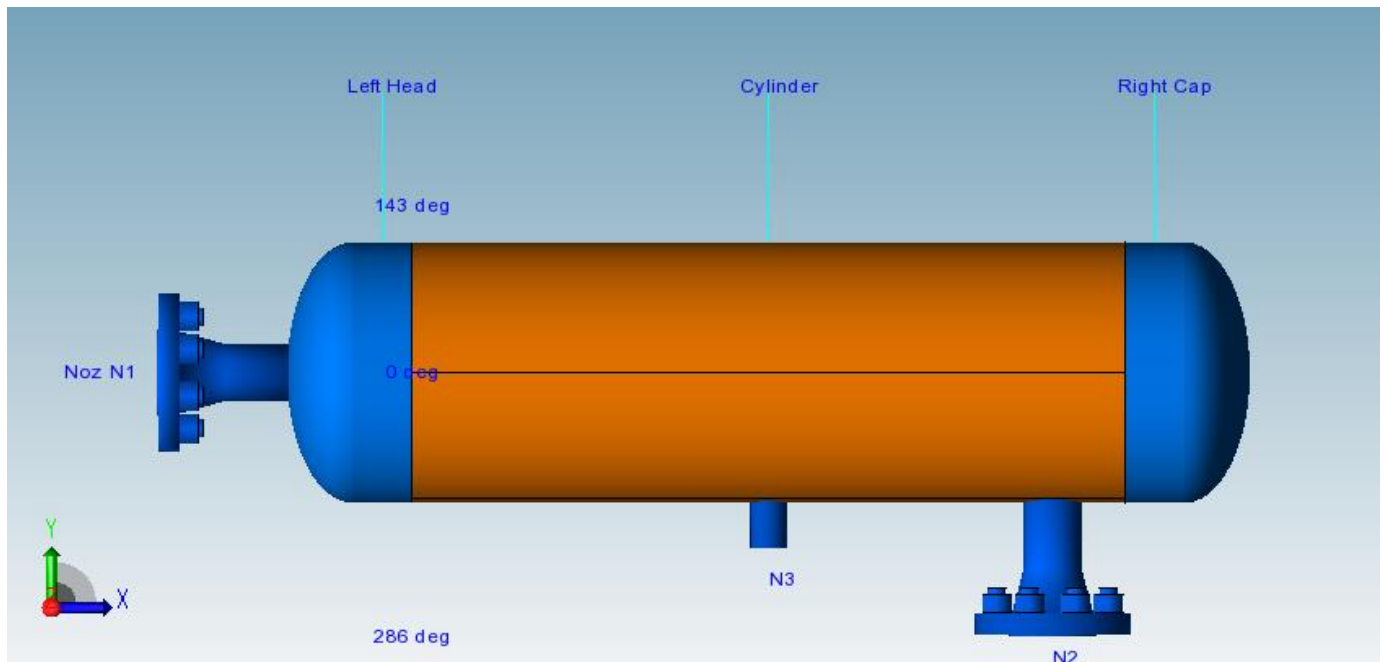

Table of Contents

Cover Sheet.....	2
Vessel Design Summary:.....	3
Nozzle Summary:	5
Nozzle Schedule:.....	5
Bill of Material:.....	7
Input Echo:.....	8
Internal Pressure Calculations:	12
Nozzle Flange MAWP Results:.....	16
Nozzle Calcs.: Noz N1.....	17
Nozzle Calcs.: N2	20
Nozzle Calcs.: N3	23

Vessel Design Summary:

ASME Code, Section VIII Division 1, 2019

Diameter Spec : 273.000 mm OD	
Vessel Design Length, Tangent to Tangent	876.72 mm
Specified Datum Line Distance	63.36 mm
Internal Design Temperature	80 °C
Internal Design Pressure	2.600 N/mm ²
External Design Temperature	80 °C
Maximum Allowable Working Pressure	3.809 N/mm ²
Shop Test Pressure	6.640 N/mm ²
Required Minimum Design Metal Temperature	-28.9 °C
Warmest Computed Minimum Design Metal Temperature	-46.0 °C
Wind Design Code	No Wind Loads
Earthquake Design Code	No Seismic

Materials of Construction:

Component Type	Material	Class	Thickness	UNS #	Normal ized	Impact Tested
Shell	SA-106 B	K03006	No	No
Head	SA-234 WPB	K03006	No	No
Nozzle	SA-106 B	K03006	No	No
Nozzle Flg	SA-105	K03504	Yes	No

Normalized is determined based on the UCS-66 material curve selection and Figure UCS-66.
 Impact Tested is based on material selection and material data properties.

Element Pressures and MAWP (N/mm² & mm):

Element Description or Type	Design Pressure + Stat. head	Ext. Press.	Element M.A.W.P	Total Corrosion Allowance	Str. Flg. Gov.	In Creep Range
Left Head	2.600	0.00	4.689	3.0000	Yes	No
Cylinder	2.600	0.00	3.809	3.0000	N/A	No
Right Cap	2.600	0.00	4.689	3.0000	Yes	No

Element Types and Properties:

Element Type	"To" Elev mm	Element Length mm	Nominal Thickness mm	Finished Thickness mm	Reqd Thk Internal mm	Reqd Thk External mm	Long Eff	Circ Eff
Ellipse	0.0	63.4	9.3	9.3	6.4	4.5	0.85	0.85
Cylinder	750.0	750.0	9.3	8.1	6.5	...	0.85	0.85
Ellipse	813.4	63.4	9.3	9.3	6.4	4.5	0.85	0.85

PV Elite 23 SP2 Licensee: PPV-Engineering B.V.

FileName : 2nd-stage Discharge_LI4736 -----

Vessel Design Summary: Step: 15 11:08am Apr 13,2022

Weights:

Fabricated - Bare W/O Removable Internals	75.3	kgm
Shop Test - Fabricated + Water (Full)	124.9	kgm
Shipping - Fab. + Rem. Intls.+ Shipping App.	75.3	kgm
Erected - Fab. + Rem. Intls.+ Insul. (etc)	75.3	kgm
Empty - Fab. + Intls. + Details + Wghts.	75.3	kgm
Operating - Empty + Operating Liquid (No CA)	75.3	kgm
Field Test - Empty Weight + Water (Full)	124.9	kgm

PV Elite is a trademark of Hexagon AB, 2021, All rights reserved.

Nozzle Calculation Summary:

Description	MAWP N/mm ²	Ext	MAPNC N/mm ²	UG-45	[tr] mm	Weld Path	Areas or Stresses
Noz N1	4.689	OK	5.79	OK	No Calc[*]
N2	3.809	OK	5.91	OK	No Calc[*]
N3	3.809	OK	5.91	OK	No Calc[*]

Nozzle MAWP Summary:

Minimum MAWP Nozzles : 3.809 Nozzle : N3
 Minimum MAWP Shells/Flanges : 3.809 Element : Cylinder
 Minimum MAPnc Shells/Flanges : 5.11 Element : Cylinder

 Computed Vessel M.A.W.P. : 3.809 N/mm²

[*] - This was a small opening and the areas were not computed.

Note: MAWPs (Internal Case) shown above are at the High Point.

Check the Spatial Relationship between the Nozzles:

From Node	Nozzle Description	X Coordinate mm	Layout Angle deg	Dia. Limit mm
10	Noz N1	0.000	0.000	97.700
20	N2	737.360	270.000	97.700
20	N3	438.360	270.000	54.672

The nozzle spacing is computed by the following:

= Sqrt(l² + lc²) where
 ll - Arc length along the inside vessel surface in the long. direction.
 lc - Arc length along the inside vessel surface in the circ. direction

If any interferences/violations are found, they will be noted below.

No interference violations have been detected!

PV Elite is a trademark of Hexagon AB, 2021, All rights reserved.

Nozzle Schedule:

Description	Nominal or Actual Size	Schd or FVC Type	Flg Type	Nozzle O/Dia mm	Wall Thk mm	Reinforcing Diameter	Pad Thk mm	Cut Length mm	Flg Class
N3	38 mm Actual		Non	38.1	8.4	5	...
Noz N1	50 mm	160	WN	60.3	8.7	7	300
N2	50 mm	160	WN	60.3	8.7	7	300

General Notes for the above table:

The Cut Length is the Outside Projection + Inside Projection + Drop + In Plane Shell Thickness. This value does not include weld gaps, nor does it account for shrinkage.

In the case of Oblique Nozzles, the Outside Diameter must be increased. The Re-Pad WIDTH around the nozzle is calculated as follows:
 Width of Pad = (Pad Outside Dia. (per above) - Nozzle Outside Dia.)/2

For hub nozzles, the thickness and diameter shown are those of the smaller and thinner section.

Nozzle Material and Weld Fillet Leg Size Details (mm):

Description	Material	Shl Grve Weld	Noz Shl/Pad Weld	Pad OD Weld	Pad Grve Weld	Inside Weld
N3	SA-106 B	8.340	6.000
Noz N1	SA-106 B	8.110	7.000
N2	SA-106 B	8.340	6.000

Note: The Outside projections below do not include the flange thickness.

Nozzle Miscellaneous Data:

Description	Elev/Distance From Datum	Layout Angle	Proj Outside	Proj Inside	Installed in Component
	mm	deg	mm	mm	
N3	375.000	270.0	47.62	0.00	Cylinder
Noz N1	...	0.0	65.00	0.00	Left Head
N2	674.000	270.0	68.00	0.00	Cylinder

PV Elite is a trademark of Hexagon AB, 2021, All rights reserved.

Bill of Materials:

QTY	DESCRIPTION	MATERIAL
2	ELLIPTICAL HEAD: 2.0 X 1, 9.3mm THK X 254.5mm ID X 63.4mm	SA-234 WPB
2	CYLINDRICAL SEGMENT 9.3mm THK X 320.4mm X 750.0mm	SA-106 B
1	CYLINDRICAL SEGMENT 9.3mm THK X 165.8mm X 750.0mm	SA-106 B
1	NAMEPLATE	...

PV Elite is a trademark of Hexagon AB, 2021, All rights reserved.

PV Elite Vessel Analysis Program: Input Data

Design Internal Pressure (for Hydrotest)	2.6	N/mm ²
Design Internal Temperature	80.0	°C
Projection of Nozzle from Vessel Top	0	mm
Projection of Nozzle from Vessel Bottom	0	mm
Minimum Design Metal Temperature	-28.9	°C
Type of Construction	Welded	
Special Service	None	
Degree of Radiography	RT-3	
Use Higher Longitudinal Stresses (Flag)	Y	
Select t for Internal Pressure (Flag)	N	
Select t for External Pressure (Flag)	N	
Select t for Axial Stress (Flag)	N	
Select Location for Stiff. Rings (Flag)	N	
Consider Vortex Shedding	N	
Perform a Corroded Hydrotest	N	

Shop Pressure Test:

Type of Pressure Test	User Entered Pressure
Pressure Test Position	Horizontal

Load Case 1	NP+EW+WI+FW+BW
Load Case 2	NP+EW+EE+FS+BS
Load Case 3	NP+OW+WI+FW+BW
Load Case 4	NP+OW+EQ+FS+BS
Load Case 5	NP+HW+HI
Load Case 6	NP+HW+HE
Load Case 7	IP+OW+WI+FW+BW
Load Case 8	IP+OW+EQ+FS+BS
Load Case 9	EP+OW+WI+FW+BW
Load Case 10	EP+OW+EQ+FS+BS
Load Case 11	HP+HW+HI
Load Case 12	HP+HW+HE
Load Case 13	IP+WE+EW
Load Case 14	IP+WF+CW
Load Case 15	IP+VO+OW
Load Case 16	IP+VE+EW
Load Case 17	NP+VO+OW
Load Case 18	FS+BS+IP+OW
Load Case 19	FS+BS+EP+OW

Wind Design Code No Wind Loads

Seismic Design Code No Seismic

Design Pressure + Static Head	Y
Consider MAP New and Cold in Noz. Design	N
Consider External Loads for Nozzle Des.	Y
Use ASME VIII-1 Appendix 1-9	N

Material Database Year Current w/Addenda or Code Year

Configuration Directives:

Do not use Nozzle MDMT Interpretation VIII-1 01-37	No
Use Table G instead of exact equation for "A"	Yes
Shell Head Joints are Tapered	Yes
Compute "K" in corroded condition	Yes
Use Code Case 2286	No
Use the MAWP to compute the MDMT	Yes
For thickness ratios <= 0.35, MDMT will be -155F (-104C)	Yes
For PWHT & P1 Materials the MDMT can be < -55F (-48C)	No

FileName : 2nd-stage Discharge_LI4736 -----

Input Echo: Step: 1 11:08am Apr 13,2022

Using Metric Material Databases, ASME II D	No
Calculate B31.3 type stress for Nozzles with Loads	Yes
Reduce the MDMT due to lower membrane stress	Yes
Consider Longitudinal Stress in MDMT calcs. (Div. 1)	Yes

Complete Listing of Vessel Elements and Details:

Element From Node	10	
Element To Node	20	
Element Type	Elliptical	
Description	Left Head	
Distance "FROM" to "TO"	63.36	mm
Element Outside Diameter	273	mm
Element Thickness	9.27	mm
Internal Corrosion Allowance	3	mm
Nominal Thickness	9.27	mm
External Corrosion Allowance	0	mm
Design Internal Pressure	2.6	N/mm ²
Design Temperature Internal Pressure	80	°C
Design External Pressure	0	N/mm ²
Design Temperature External Pressure	80	°C
Effective Diameter Multiplier	1.2	
Material Name	SA-234 WPB	
Allowable Stress, Ambient	117.9	N/mm ²
Allowable Stress, Operating	117.9	N/mm ²
Allowable Stress, Hydrotest	153.27	N/mm ²
Material Density	7750.4	kg/m ³
P Number Thickness	30.988	mm
Yield Stress, Operating	223.97	N/mm ²
UCS-66 Chart Curve Designation	B	
External Pressure Chart Name	CS-2	
UNS Number	K03006	
Product Form	Smls. & wld. fittings	
Efficiency, Longitudinal Seam	0.85	
Efficiency, Circumferential Seam	0.85	
Elliptical Head Factor	2.0	
Weld is pre-Heated	No	

Element From Node	10	
Detail Type	Nozzle	
Detail ID	Noz N1	
Dist. from "FROM" Node / Offset dist	0	mm
Nozzle Diameter	50	mm
Nozzle Schedule	160	
Nozzle Class	300	
Layout Angle	0.0	
Blind Flange (Y/N)	N	
Weight of Nozzle (Used if > 0)	0	N
Grade of Attached Flange	GR 1.1	
Nozzle Matl	SA-106 B	

Element From Node	20	
Element To Node	30	
Element Type	Cylinder	
Description	Cylinder	
Distance "FROM" to "TO"	750	mm
Element Outside Diameter	273	mm
Element Thickness	8.11	mm
Internal Corrosion Allowance	3	mm
Nominal Thickness	9.27	mm
External Corrosion Allowance	0	mm
Design Internal Pressure	2.6	N/mm ²

FileName : 2nd-stage Discharge_LI4736 -----

Input Echo: Step: 1 11:08am Apr 13,2022

Design Temperature Internal Pressure	80	°C
Design External Pressure	0	N/mm ²
Design Temperature External Pressure	80	°C
Effective Diameter Multiplier	1.2	
Material Name	SA-106 B	
Allowable Stress, Ambient	117.9	N/mm ²
Allowable Stress, Operating	117.9	N/mm ²
Allowable Stress, Hydrotest	153.27	N/mm ²
Material Density	7750.4	kg/m ³
P Number Thickness	30.988	mm
Yield Stress, Operating	223.97	N/mm ²
UCS-66 Chart Curve Designation	B	
External Pressure Chart Name	CS-2	
UNS Number	K03006	
Product Form	Smls. pipe	
Efficiency, Longitudinal Seam	0.85	
Efficiency, Circumferential Seam	0.85	
Weld is pre-Heated	No	

Element From Node	20	
Detail Type	Nozzle	
Detail ID	N2	
Dist. from "FROM" Node / Offset dist	674	mm
Nozzle Diameter	50	mm
Nozzle Schedule	160	
Nozzle Class	300	
Layout Angle	270.0	
Blind Flange (Y/N)	N	
Weight of Nozzle (Used if > 0)	0	N
Grade of Attached Flange	GR 1.1	
Nozzle Matl	SA-106 B	

Element From Node	20	
Detail Type	Nozzle	
Detail ID	N3	
Dist. from "FROM" Node / Offset dist	375	mm
Nozzle Diameter	38.1	mm
Nozzle Schedule	None	
Nozzle Class	None	
Layout Angle	270.0	
Blind Flange (Y/N)	N	
Weight of Nozzle (Used if > 0)	0	N
Grade of Attached Flange	None	
Nozzle Matl	SA-106 B	

FileName : 2nd-stage Discharge_LI4736 -----

Input Echo: Step: 1 11:08am Apr 13,2022

Element From Node	30	
Element To Node	40	
Element Type	Elliptical	
Description	Right Cap	
Distance "FROM" to "TO"	63.36	mm
Element Outside Diameter	273	mm
Element Thickness	9.27	mm
Internal Corrosion Allowance	3	mm
Nominal Thickness	9.27	mm
External Corrosion Allowance	0	mm
Design Internal Pressure	2.6	N/mm ²
Design Temperature Internal Pressure	80	°C
Design External Pressure	0	N/mm ²
Design Temperature External Pressure	80	°C
Effective Diameter Multiplier	1.2	
Material Name	SA-234 WPB	
Allowable Stress, Ambient	117.9	N/mm ²
Allowable Stress, Operating	117.9	N/mm ²
Allowable Stress, Hydrotest	153.27	N/mm ²
Material Density	7750.4	kg/m ³
P Number Thickness	30.988	mm
Yield Stress, Operating	223.97	N/mm ²
UCS-66 Chart Curve Designation	B	
External Pressure Chart Name	CS-2	
UNS Number	K03006	
Product Form	Smls. & wld. fittings	
Efficiency, Longitudinal Seam	0.85	
Efficiency, Circumferential Seam	0.85	
Elliptical Head Factor	2.0	
Weld is pre-Heated	No	

PV Elite is a trademark of Hexagon AB, 2021, All rights reserved.

Internal Pressure Results Summary:

Element Thickness, Pressure, Diameter and Allowable Stress :

From	To	Int. Press + Liq. Hd N/mm ²	Nominal Thickness mm	Total Corr Allowance mm	Element Diameter mm	Allowable Stress (SE) N/mm ²
Left Head		2.6	9.27	3	273	100.22
Cylinder		2.6	9.27	3	273	100.22
Right Cap		2.6	9.27	3	273	100.22

Element Required Thickness and MAWP :

From	To	Design Pressure N/mm ²	M.A.W.P. Corroded N/mm ²	M.A.P. New & Cold N/mm ²	Minimum Thickness mm	Required Thickness mm
Left Head		2.6	4.689	7.249	9.27	6.36037
Cylinder		2.6	3.809	6.099	8.11	6.505
Right Cap		2.6	4.689	7.249	9.27	6.36037
Minimum			3.809	5.11		

Note : The M.A.P.(NC) is Governed by a Flange !

MAWP: 3.809 N/mm², limited by: Cylinder.

Elements Suitable for Design Internal Pressure.

Internal Pressure Calculation Results:

ASME Code, Section VIII Division 1, 2019

Elliptical Head From 10 To 20 SA-234 WPB , UCS-66 Crv. B at 80 °C

Left Head

Material UNS Number: K03006

Required Thickness due to Internal Pressure [tr]:

$$= (P \cdot Do \cdot K_{cor}) / (2 \cdot S \cdot E + 2 \cdot P \cdot (K_{cor} - 0.1)) \text{ per Appendix 1-4 (c)}$$

$$= (2.6 \cdot 273 \cdot 0.97) / (2 \cdot 117.9 \cdot 0.85 + 2 \cdot 2.6 \cdot (0.97 - 0.1))$$

$$= 3.3604 + 3.0000 = 6.3604 \text{ mm}$$

Max. Allowable Working Pressure at given Thickness, corroded [MAWP]:

$$= (2 \cdot S \cdot E \cdot t) / (K_{cor} \cdot Do - 2 \cdot t \cdot (K_{cor} - 0.1)) \text{ per Appendix 1-4 (c)}$$

$$= (2 \cdot 117.9 \cdot 0.85 \cdot 6.27) / (0.97 \cdot 273 - 2 \cdot 6.27 \cdot (0.97 - 0.1))$$

$$= 4.948 \text{ N/mm}^2$$

Maximum Allowable Pressure, New and Cold [MAPNC]:

$$= (2 \cdot S \cdot E \cdot t) / (K \cdot Do - 2 \cdot t \cdot (K - 0.1)) \text{ per Appendix 1-4 (c)}$$

$$= (2 \cdot 117.9 \cdot 0.85 \cdot 9.27) / (1 \cdot 273 - 2 \cdot 9.27 \cdot (1 - 0.1))$$

$$= 7.249 \text{ N/mm}^2$$

Actual stress at given pressure and thickness, corroded [Sact]:

$$= (P \cdot (K_{cor} \cdot Do - 2 \cdot t \cdot (K_{cor} - 0.1))) / (2 \cdot E \cdot t)$$

$$= (2.6 \cdot (0.97 \cdot 273 - 2 \cdot 6.27 \cdot (0.97 - 0.1))) / (2 \cdot 0.85 \cdot 6.27)$$

$$= 61.953 \text{ N/mm}^2$$

Straight Flange Required Thickness:

$$= (P \cdot Ro) / (S \cdot E + 0.4 \cdot P) + ca \text{ per Appendix 1-1 (a) (1)}$$

$$= (2.6 \cdot 136.5) / (117.9 \cdot 0.85 + 0.4 \cdot 2.6) + 3$$

PV Elite 23 SP2 Licensee: PPV-Engineering B.V.

FileName : 2nd-stage Discharge_LI4736 -----

Nozzle Flange MAWP: Step: 6 11:08am Apr 13,2022

= 6.505 mm

Straight Flange Maximum Allowable Working Pressure:

= $(S \cdot E \cdot t) / (R_o - 0.4 \cdot t)$ per Appendix 1-1 (a) (1)
 = $(117.9 \cdot 0.85 \cdot 6.27) / (136.5 - 0.4 \cdot 6.27)$
 = 4.689 N/mm²

Factor K, corroded condition [Kcor]:

= $(2 + (\text{Inside Diameter} / (2 \cdot \text{Inside Head Depth}))^2) / 6$
 = $(2 + (260.5 / (2 \cdot 66.61))^2) / 6$
 = 0.970315

MDMT Calculations in the Knuckle Portion:

Govrn. thk, tg = 9.27, tr = 4.873, c = 3 mm, E* = 0.85
 Thickness Ratio = $tr \cdot (E^*) / (tg - c) = 0.661$, Temp. Reduction = 19 °C

Min Metal Temp. w/o impact per UCS-66, Curve B -29 °C
 Min Metal Temp. at Required thickness (UCS 66.1) -48 °C

MDMT Calculations in the Head Straight Flange:

Govrn. thk, tg = 9.27, tr = 5.11, c = 3 mm, E* = 0.85
 Thickness Ratio = $tr \cdot (E^*) / (tg - c) = 0.693$, Temp. Reduction = 17 °C

Min Metal Temp. w/o impact per UCS-66, Curve B -29 °C
 Min Metal Temp. at Required thickness (UCS 66.1) -46 °C

Cylindrical Shell From 20 To 30 SA-106 B , UCS-66 Crv. B at 80 °C

Cylinder

Longitudinal Joint: Seamless

Material UNS Number: K03006

Required Thickness due to Internal Pressure [tr]:

= $(P \cdot R_o) / (S \cdot E + 0.4 \cdot P)$ per Appendix 1-1 (a) (1)
 = $(2.6 \cdot 136.5) / (117.9 \cdot 0.85 + 0.4 \cdot 2.6)$
 = 3.5050 + 3.0000 = 6.5050 mm

Max. Allowable Working Pressure at given Thickness, corroded [MAWP]:

= $(S \cdot E \cdot t) / (R_o - 0.4 \cdot t)$ per Appendix 1-1 (a) (1)
 = $(117.9 \cdot 0.85 \cdot 5.11) / (136.5 - 0.4 \cdot 5.11)$
 = 3.809 N/mm²

Maximum Allowable Pressure, New and Cold [MAPNC]:

= $(S \cdot E \cdot t) / (R_o - 0.4 \cdot t)$ per Appendix 1-1 (a) (1)
 = $(117.9 \cdot 0.85 \cdot 8.11) / (136.5 - 0.4 \cdot 8.11)$
 = 6.099 N/mm²

Actual stress at given pressure and thickness, corroded [Sact]:

= $(P \cdot (R_o - 0.4 \cdot t)) / (E \cdot t)$
 = $(2.6 \cdot (136.5 - 0.4 \cdot 5.11)) / (0.85 \cdot 5.11)$
 = 80.485 N/mm²

Minimum Design Metal Temperature Results:

Govrn. thk, tg = 8.11, tr = 2.478, c = 3 mm, E* = 0.85
 Thickness Ratio = $tr \cdot (E^*) / (tg - c) = 0.412$, Temp. Reduction = 48 °C

Min Metal Temp. w/o impact per UCS-66, Curve B -29 °C
 Min Metal Temp. at Required thickness (UCS 66.1) -48 °C

Elliptical Head From 30 To 40 SA-234 WPB , UCS-66 Crv. B at 80 °C

Right Cap
 Material UNS Number: K03006

Required Thickness due to Internal Pressure [tr]:
 $= (P \cdot Do \cdot K_{cor}) / (2 \cdot S \cdot E + 2 \cdot P \cdot (K_{cor} - 0.1))$ per Appendix 1-4 (c)
 $= (2.6 \cdot 273 \cdot 0.97) / (2 \cdot 117.9 \cdot 0.85 + 2 \cdot 2.6 \cdot (0.97 - 0.1))$
 $= 3.3604 + 3.0000 = 6.3604 \text{ mm}$

Max. Allowable Working Pressure at given Thickness, corroded [MAWP]:
 $= (2 \cdot S \cdot E \cdot t) / (K_{cor} \cdot Do - 2 \cdot t \cdot (K_{cor} - 0.1))$ per Appendix 1-4 (c)
 $= (2 \cdot 117.9 \cdot 0.85 \cdot 6.27) / (0.97 \cdot 273 - 2 \cdot 6.27 \cdot (0.97 - 0.1))$
 $= 4.948 \text{ N/mm}^2$

Maximum Allowable Pressure, New and Cold [MAPNC]:
 $= (2 \cdot S \cdot E \cdot t) / (K \cdot Do - 2 \cdot t \cdot (K - 0.1))$ per Appendix 1-4 (c)
 $= (2 \cdot 117.9 \cdot 0.85 \cdot 9.27) / (1 \cdot 273 - 2 \cdot 9.27 \cdot (1 - 0.1))$
 $= 7.249 \text{ N/mm}^2$

Actual stress at given pressure and thickness, corroded [Sact]:
 $= (P \cdot (K_{cor} \cdot Do - 2 \cdot t \cdot (K_{cor} - 0.1))) / (2 \cdot E \cdot t)$
 $= (2.6 \cdot (0.97 \cdot 273 - 2 \cdot 6.27 \cdot (0.97 - 0.1))) / (2 \cdot 0.85 \cdot 6.27)$
 $= 61.953 \text{ N/mm}^2$

Straight Flange Required Thickness:
 $= (P \cdot Ro) / (S \cdot E + 0.4 \cdot P) + ca$ per Appendix 1-1 (a) (1)
 $= (2.6 \cdot 136.5) / (117.9 \cdot 0.85 + 0.4 \cdot 2.6) + 3$
 $= 6.505 \text{ mm}$

Straight Flange Maximum Allowable Working Pressure:
 $= (S \cdot E \cdot t) / (Ro - 0.4 \cdot t)$ per Appendix 1-1 (a) (1)
 $= (117.9 \cdot 0.85 \cdot 6.27) / (136.5 - 0.4 \cdot 6.27)$
 $= 4.689 \text{ N/mm}^2$

Factor K, corroded condition [Kcor]:
 $= (2 + (\text{Inside Diameter} / (2 \cdot \text{Inside Head Depth}))^2) / 6$
 $= (2 + (260.5 / (2 \cdot 66.61))^2) / 6$
 $= 0.970315$

MDMT Calculations in the Knuckle Portion:

Govrn. thk, tg = 9.27, tr = 4.873, c = 3 mm, E* = 0.85
 Thickness Ratio = tr * (E*) / (tg - c) = 0.661, Temp. Reduction = 19 °C

Min Metal Temp. w/o impact per UCS-66, Curve B -29 °C
 Min Metal Temp. at Required thickness (UCS 66.1) -48 °C

MDMT Calculations in the Head Straight Flange:

Govrn. thk, tg = 9.27, tr = 5.11, c = 3 mm, E* = 0.85
 Thickness Ratio = tr * (E*) / (tg - c) = 0.693, Temp. Reduction = 17 °C

Min Metal Temp. w/o impact per UCS-66, Curve B -29 °C
 Min Metal Temp. at Required thickness (UCS 66.1) -46 °C

Note: Heads and Shells Exempted to -20F (-29C) by paragraph UG-20F

Hydrostatic Test Pressure Results:

Pressure per UG99b	= 1.30 * M.A.W.P. * Sa/S	4.951	N/mm ²
Pressure per UG99b[35]	= 1.30 * Design Pres * Sa/S	3.380	N/mm ²
Pressure per UG99c	= 1.30 * M.A.P. - Head(Hyd)	6.643	N/mm ²
Pressure per UG100	= 1.10 * M.A.W.P. * Sa/S	4.190	N/mm ²

PV Elite 23 SP2 Licensee: PPV-Engineering B.V.

FileName : 2nd-stage Discharge_LI4736 -----

Nozzle Flange MAWP: Step: 6 11:08am Apr 13,2022

Pressure per PED = max(1.43*DP, 1.25*DP*ratio) 3.718 N/mm²
 Pressure per App 27-4 = M.A.W.P. 3.809 N/mm²
 User Defined Hydrostatic Test Pressure at High Point 6.640 N/mm²

Horizontal Test performed per: User Hydro Pressure

Please note that Nozzle, Shell, Head, Flange, etc MAWPs are all considered when determining the hydrotest pressure for those test types that are based on the MAWP of the vessel.

Stresses on Elements due to Test Pressure (N/mm²):

From To	Stress	Allowable	Ratio	Pressure
Left Head	108.0	153.3	0.705	6.64
Cylinder	128.4	153.3	0.838	6.64
Right Cap	108.0	153.3	0.705	6.64

Stress ratios for Nozzle and Pad Materials (N/mm²):

Description	Pad/Nozzle	Ambient	Operating	Ratio
Noz N1	Nozzle	117.90	117.90	1.000
N2	Nozzle	117.90	117.90	1.000
N3	Nozzle	117.90	117.90	1.000
Minimum				1.000

Stress ratios for Pressurized Vessel Elements (N/mm²):

Description	Ambient	Operating	Ratio
Left Head	117.90	117.90	1.000
Cylinder	117.90	117.90	1.000
Right Cap	117.90	117.90	1.000
Minimum			1.000

Hoop Stress in Nozzle Wall during Pressure Test (N/mm²):

Description	Ambient	Operating	Ratio
Noz N1	20.27	153.27	0.132
N2	20.27	153.27	0.132
N3	12.44	153.27	0.081

Elements Suitable for Test Pressure.

PV Elite is a trademark of Hexagon AB, 2021, All rights reserved.

FileName : 2nd-stage Discharge_LI4736 -----

Nozzle Flange MAWP: Step: 6 11:08am Apr 13,2022

Nozzle Flange MAWP Results: (N/mm² & °C)

Nozzle Description	Flange Rating		Design Temp	Class	Grade/ Group	Equiv. Press	Max Pressure		
	Ope.	Ambient					UG-44(b)	50%	DNV
Noz N1	4.80	5.11	80	300	GR 1.1
N2	4.80	5.11	80	300	GR 1.1
Min Rating	4.800	5.110 N/mm ² [for Core Elements]					0.000	0.000	0.000

Pressure Ratings are per ASME B16.5 2013 Metric Edition

PV Elite is a trademark of Hexagon AB, 2021, All rights reserved.

Input, Nozzle Desc: Noz N1 From: 10

Pressure for Reinforcement Calculations	P	2.6000	N/mm ²
Temperature for Internal Pressure	Temp	80	°C
Parent Material		SA-234 WPB	
Parent Allowable Stress at Temperature	Sv	117.90	N/mm ²
Parent Allowable Stress At Ambient	Sva	117.90	N/mm ²
Inside Diameter of Elliptical Head	D	254.46	mm
Aspect Ratio of Elliptical Head	Ar	2.00	
Head Finished (Minimum) Thickness	t	9.2700	mm
Head Internal Corrosion Allowance	c	3.0000	mm
Head External Corrosion Allowance	co	0.0000	mm
Distance from Head Centerline	L1	0.0000	mm
User Entered Minimum Design Metal Temperature		-28.89	°C

Type of Element Connected to the Parent : Nozzle

Material		SA-106 B	
Material UNS Number		K03006	
Material Specification/Type		Smls. pipe	
Allowable Stress at Temperature	Sn	117.90	N/mm ²
Allowable Stress At Ambient	Sna	117.90	N/mm ²
Diameter Basis (for tr calc only)		Outside	
Layout Angle		0.00	deg
Diameter		50.0000	mm
Size and Thickness Basis		Nominal	
Nominal Thickness		160	
Flange Material		SA-105	
Flange Type		Weld Neck Flange	
Corrosion Allowance	can	3.0000	mm
Joint Efficiency of Shell Seam at Nozzle	E1	1.00	
Joint Efficiency of Nozzle Neck	En	1.00	
Outside Projection	ho	65.0000	mm
Weld leg size between Nozzle and Pad/Shell	Wo	7.0000	mm
Groove weld depth between Nozzle and Vessel	Wgnv	8.1100	mm
Flange Class		300	
Flange Grade		GR 1.1	

The Pressure Design option was Design Pressure + static head.

Nozzle Sketch (may not represent actual weld type/configuration)

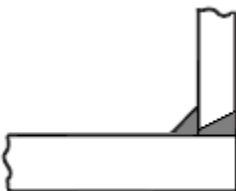

Abutting/Set-on Nozzle No Pad

Reinforcement CALCULATION, Description: Noz N1

ASME Code, Section VIII, Div. 1, 2019, UG-37 to UG-45

Actual Outside Diameter Used in Calculation 60.325 mm.
 Actual Thickness Used in Calculation 8.738 mm

Nozzle input data check completed without errors.

Reqd thk per UG-37(a) of Elliptical Head, tr [Int. Press]
 = $P \cdot D \cdot K1 / (2 \cdot Sv \cdot E - 0.2 \cdot P)$ per Appendix 1-4(c)
 = $0.881 \cdot 2.6 \cdot 260.5 / (2 \cdot 117.9 \cdot 1 - 0.2 \cdot 2.6)$
 = 2.5349 mm

Reqd thk per UG-37(a) of Nozzle Wall, trn [Int. Press]
 = $P \cdot Ro / (Sn \cdot E + 0.4 \cdot P)$ per Appendix 1-1 (a) (1)
 = $2.6 \cdot 30.16 / (117.9 \cdot 1 + 0.4 \cdot 2.6)$
 = 0.6593 mm

UG-40, Limits of Reinforcement : [Internal Pressure]

Parallel to Vessel Wall (Diameter Limit)	D1	97.6996	mm
Parallel to Vessel Wall, opening length	d	48.8498	mm
Normal to Vessel Wall (Thickness Limit), no pad	Tlnp	14.3440	mm

Note:

*Taking a UG-36(c)(3)(a) exemption for nozzle: Noz N1.
 This calculation is valid for nozzles that meet all the requirements of
 paragraph UG-36. Please check the Code carefully, especially for nozzles
 that are not isolated or do not meet Code spacing requirements. To force
 the computation of areas for small nozzles go to Tools->Configuration
 and check the box to force the UG-37 small nozzle area calculation or
 force the Appendix 1-10 computation in Nozzle Design Options.*

UG-45 Minimum Nozzle Neck Thickness Requirement: [Int. Press.]

Wall Thickness for Internal/External pressures	ta	= 3.6593	mm
Wall Thickness per UG16(b),	tr16b	= 4.5000	mm
Wall Thickness, shell/head, internal pressure	trb1	= 5.7928	mm
Wall Thickness	tb1 = max(trb1, tr16b)	= 5.7928	mm
Wall Thickness	tb2 = max(trb2, tr16b)	= 4.5000	mm
Wall Thickness per table UG-45	tb3	= 6.4200	mm

Determine Nozzle Thickness candidate [tb]:

= min[tb3, max(tb1, tb2)]
 = min[6.42, max(5.793, 4.5)]
 = 5.7928 mm

Minimum Wall Thickness of Nozzle Necks [tUG-45]:

= max(ta, tb)
 = max(3.659, 5.793)
 = 5.7928 mm

Available Nozzle Neck Thickness = $0.875 \cdot 8.738 = 7.645$ mm --> OK

PV Elite 23 SP2 Licensee: PPV-Engineering B.V.
 FileName : 2nd-stage Discharge_LI4736 -----
 Nozzle Calcs.: Noz N1 Nozl: 13 11:08am Apr 13,2022

Nozzle Junction Minimum Design Metal Temperature (MDMT) Calculations:

Nozzle Neck to Flange Weld, Curve: B

Govrn. thk, tg = 7.645, tr = 0.659, c = 3 mm, E* = 1
 Thickness Ratio = $tr \cdot (E^*) / (tg - c) = 0.142$, Temp. Reduction = 78 °C

Min Metal Temp. w/o impact per UCS-66, Curve B -29 °C
 Min Metal Temp. at Required thickness (UCS 66.1) -104 °C

Nozzle-Shell/Head Weld (UCS-66(a)1(b)), Curve: B

Govrn. thk, tg = 7.645, tr = 0.659, c = 3 mm, E* = 1
 Thickness Ratio = $tr \cdot (E^*) / (tg - c) = 0.142$, Temp. Reduction = 78 °C

Min Metal Temp. w/o impact per UCS-66, Curve B -29 °C
 Min Metal Temp. at Required thickness (UCS 66.1) -104 °C

Gov. MDMT of the nozzle to shell joint welded assembly : -104 °C

ANSI Flange MDMT including Temperature reduction per UCS-66.1:

Unadjusted MDMT of ASME B16.5/47 flanges per UCS-66(c) -18 °C
 Flange MDMT with Temp reduction per UCS-66(b) (1) (-b) -48 °C

Where the Stress Reduction Ratio per UCS-66(b)(1)(-b) is :
 Design Pressure/Ambient Rating = $2.60 / 5.11 = 0.509$

Weld Size Calculations, Description: Noz N1

Intermediate Calc. for nozzle/shell Welds Tmin 5.7376 mm

Results Per UW-16.1:

	Required Thickness	Actual Thickness
Nozzle Weld	$4.0163 = 0.7 \cdot t_{min}$	$4.9490 = 0.7 \cdot W_o$ mm

Skipping the nozzle attachment weld strength calculations.
 Per UW-15(b)(2) the nozzles exempted by UG-36(c)(3)(a)
 (small nozzles) do not require a weld strength check.

Maximum Allowable Pressure for this Nozzle at this Location:

Converged Max. Allow. Pressure in Operating case 4.689 N/mm²

Note: The MAWP of this junction was limited by the parent Shell/Head.

The Drop for this Nozzle is : 1.9319 mm
 The Cut Length for this Nozzle is, Drop + Ho + H + T : 76.2019 mm

PV Elite is a trademark of Hexagon AB, 2021, All rights reserved.

Input, Nozzle Desc: N2

From: 20

Pressure for Reinforcement Calculations	P	2.6000	N/mm ²
Temperature for Internal Pressure	Temp	80	°C
Parent Material		SA-106 B	
Parent Allowable Stress at Temperature	Sv	117.90	N/mm ²
Parent Allowable Stress At Ambient	Sva	117.90	N/mm ²
Inside Diameter of Cylindrical Shell	D	254.46	mm
Shell Finished (Minimum) Thickness	t	8.1100	mm
Shell Internal Corrosion Allowance	c	3.0000	mm
Shell External Corrosion Allowance	co	0.0000	mm
Distance from Bottom/Left Tangent		737.36	mm
User Entered Minimum Design Metal Temperature		-28.89	°C

Type of Element Connected to the Parent : Nozzle

Material		SA-106 B	
Material UNS Number		K03006	
Material Specification/Type		Smls. pipe	
Allowable Stress at Temperature	Sn	117.90	N/mm ²
Allowable Stress At Ambient	Sna	117.90	N/mm ²
Diameter Basis (for tr calc only)		Outside	
Layout Angle		270.00	deg
Diameter		50.0000	mm
Size and Thickness Basis		Nominal	
Nominal Thickness		160	
Flange Material		SA-105	
Flange Type		Weld Neck Flange	
Corrosion Allowance	can	3.0000	mm
Joint Efficiency of Shell Seam at Nozzle	E1	1.00	
Joint Efficiency of Nozzle Neck	En	1.00	
Outside Projection	ho	68.0000	mm
Weld leg size between Nozzle and Pad/Shell	Wo	6.0000	mm
Groove weld depth between Nozzle and Vessel	Wgnv	8.3400	mm
Flange Class		300	
Flange Grade		GR 1.1	

The Pressure Design option was Design Pressure + static head.

Nozzle Sketch (may not represent actual weld type/configuration)



Abutting/Set-on Nozzle No Pad

Reinforcement CALCULATION, Description: N2

ASME Code, Section VIII, Div. 1, 2019, UG-37 to UG-45

Actual Outside Diameter Used in Calculation 60.325 mm.
 Actual Thickness Used in Calculation 8.738 mm

Nozzle input data check completed without errors.

Reqd thk per UG-37(a) of Cylindrical Shell, tr [Int. Press]

$$= P \cdot R / (S_v \cdot E - 0.6 \cdot P) \text{ per UG-27 (c) (1)}$$

$$= 2.6 \cdot 130.2 / (117.9 \cdot 1 - 0.6 \cdot 2.6)$$

$$= 2.9104 \text{ mm}$$

Reqd thk per UG-37(a) of Nozzle Wall, trn [Int. Press]

$$= P \cdot R_o / (S_n \cdot E + 0.4 \cdot P) \text{ per Appendix 1-1 (a) (1)}$$

$$= 2.6 \cdot 30.16 / (117.9 \cdot 1 + 0.4 \cdot 2.6)$$

$$= 0.6593 \text{ mm}$$

UG-40, Limits of Reinforcement : [Internal Pressure]

Parallel to Vessel Wall (Diameter Limit)	Dl	97.6996	mm
Parallel to Vessel Wall, opening length	d	48.8498	mm
Normal to Vessel Wall (Thickness Limit), no pad	Tlnp	12.7750	mm

Note:

*Taking a UG-36(c)(3)(a) exemption for nozzle: N2.
 This calculation is valid for nozzles that meet all the requirements of paragraph UG-36. Please check the Code carefully, especially for nozzles that are not isolated or do not meet Code spacing requirements. To force the computation of areas for small nozzles go to Tools->Configuration and check the box to force the UG-37 small nozzle area calculation or force the Appendix 1-10 computation in Nozzle Design Options.*

UG-45 Minimum Nozzle Neck Thickness Requirement: [Int. Press.]

Wall Thickness for Internal/External pressures	ta	= 3.6593	mm
Wall Thickness per UG16(b),	tr16b	= 4.5000	mm
Wall Thickness, shell/head, internal pressure	trb1	= 5.9104	mm
Wall Thickness	tb1 = max(trb1, tr16b)	= 5.9104	mm
Wall Thickness	tb2 = max(trb2, tr16b)	= 4.5000	mm
Wall Thickness per table UG-45	tb3	= 6.4200	mm

Determine Nozzle Thickness candidate [tb]:

$$= \min[tb3, \max(tb1, tb2)]$$

$$= \min[6.42, \max(5.91, 4.5)]$$

$$= 5.9104 \text{ mm}$$

Minimum Wall Thickness of Nozzle Necks [tUG-45]:

$$= \max(ta, tb)$$

$$= \max(3.659, 5.91)$$

$$= 5.9104 \text{ mm}$$

Available Nozzle Neck Thickness = 0.875 * 8.738 = 7.645 mm --> OK

Nozzle Junction Minimum Design Metal Temperature (MDMT) Calculations:

Nozzle Neck to Flange Weld, min(Curve:B, Curve:A)

Govrn. thk, tg = 7.645, tr = 0.659, c = 3 mm, E* = 1
 Thickness Ratio = tr * (E*) / (tg - c) = 0.142, Temp. Reduction = 78 °C

Min Metal Temp. w/o impact per UCS-66, Curve A -8 °C

PV Elite 23 SP2 Licensee: PPV-Engineering B.V.

FileName : 2nd-stage Discharge_LI4736 -----

Nozzle Calcs.: N2

Noz1: 14 11:08am Apr 13,2022

Min Metal Temp. at Required thickness (UCS 66.1) -104 °C
 Min Metal Temp. w/o impact per UG-20(f) -29 °C

Nozzle-Shell/Head Weld (UCS-66(a)(1)(b)), Curve: B

Govrn. thk, tg = 7.645, tr = 0.659, c = 3 mm, E* = 1
 Thickness Ratio = $tr * (E*) / (tg - c) = 0.142$, Temp. Reduction = 78 °C

Min Metal Temp. w/o impact per UCS-66, Curve B -29 °C
 Min Metal Temp. at Required thickness (UCS 66.1) -104 °C

Gov. MDMT of the nozzle to shell joint welded assembly : -104 °C

ANSI Flange MDMT including Temperature reduction per UCS-66.1:

Unadjusted MDMT of ASME B16.5/47 flanges per UCS-66(c) -18 °C
 Flange MDMT with Temp reduction per UCS-66(b)(1)(-b) -48 °C

Where the Stress Reduction Ratio per UCS-66(b)(1)(-b) is :

Design Pressure/Ambient Rating = $2.60 / 5.11 = 0.509$

Weld Size Calculations, Description: N2

Intermediate Calc. for nozzle/shell Welds Tmin 5.7376 mm

Results Per UW-16.1:

	Required Thickness	Actual Thickness
Nozzle Weld	$4.0163 = 0.7 * t_{min}$	$4.2420 = 0.7 * W_o$ mm

Skipping the nozzle attachment weld strength calculations.
 Per UW-15(b)(2) the nozzles exempted by UG-36(c)(3)(a)
 (small nozzles) do not require a weld strength check.

Maximum Allowable Pressure for this Nozzle at this Location:

Converged Max. Allow. Pressure in Operating case 3.809 N/mm²

Note: The MAWP of this junction was limited by the parent Shell/Head.

The Drop for this Nozzle is : 3.6270 mm

The Cut Length for this Nozzle is, Drop + Ho + H + T : 79.7370 mm

Note: This nozzle or its diameter limit intersects weld seam # [3] on this element. The distance between the nozzle and seam is, 36.37 mm , while the distance from the center of the nozzle to the edge of the diameter limit is: 48.85 mm

PV Elite is a trademark of Hexagon AB, 2021, All rights reserved.

Input, Nozzle Desc: N3 From: 20

Pressure for Reinforcement Calculations	P	2.6000	N/mm ²
Temperature for Internal Pressure	Temp	80	°C
Parent Material		SA-106 B	
Parent Allowable Stress at Temperature	Sv	117.90	N/mm ²
Parent Allowable Stress At Ambient	Sva	117.90	N/mm ²
Inside Diameter of Cylindrical Shell	D	254.46	mm
Shell Finished (Minimum) Thickness	t	8.1100	mm
Shell Internal Corrosion Allowance	c	3.0000	mm
Shell External Corrosion Allowance	co	0.0000	mm
Distance from Bottom/Left Tangent		438.36	mm
User Entered Minimum Design Metal Temperature		-28.89	°C

Type of Element Connected to the Parent : Nozzle

Material		SA-106 B	
Material UNS Number		K03006	
Material Specification/Type		Smls. pipe	
Allowable Stress at Temperature	Sn	117.90	N/mm ²
Allowable Stress At Ambient	Sna	117.90	N/mm ²
Diameter Basis (for tr calc only)		Outside	
Layout Angle		270.00	deg
Diameter		38.1000	mm
Size and Thickness Basis		Actual	
Actual Thickness	tn	8.3820	mm
Corrosion Allowance	can	3.0000	mm
Joint Efficiency of Shell Seam at Nozzle	E1	1.00	
Joint Efficiency of Nozzle Neck	En	1.00	
Outside Projection	ho	47.6250	mm
Weld leg size between Nozzle and Pad/Shell	Wo	6.0000	mm
Groove weld depth between Nozzle and Vessel	Wgnv	8.3400	mm

The Pressure Design option was Design Pressure + static head.

Nozzle Sketch (may not represent actual weld type/configuration)



Abutting/Set-on Nozzle No Pad

Reinforcement CALCULATION, Description: N3

ASME Code, Section VIII, Div. 1, 2019, UG-37 to UG-45

Actual Outside Diameter Used in Calculation 38.100 mm.
 Actual Thickness Used in Calculation 8.382 mm

Nozzle input data check completed without errors.

Reqd thk per UG-37(a) of Cylindrical Shell, tr [Int. Press]

$$= P \cdot R / (S_v \cdot E - 0.6 \cdot P) \text{ per UG-27 (c) (1)}$$

$$= 2.6 \cdot 130.2 / (117.9 \cdot 1 - 0.6 \cdot 2.6)$$

$$= 2.9104 \text{ mm}$$

Reqd thk per UG-37(a) of Nozzle Wall, trn [Int. Press]

$$= P \cdot R_o / (S_n \cdot E + 0.4 \cdot P) \text{ per Appendix 1-1 (a) (1)}$$

$$= 2.6 \cdot 19.05 / (117.9 \cdot 1 + 0.4 \cdot 2.6)$$

$$= 0.4164 \text{ mm}$$

UG-40, Limits of Reinforcement : [Internal Pressure]

Parallel to Vessel Wall (Diameter Limit)	D1	54.6720	mm
Parallel to Vessel Wall, opening length	d	27.3360	mm
Normal to Vessel Wall (Thickness Limit), no pad	Tlnp	12.7750	mm

Note:

*Taking a UG-36(c)(3)(a) exemption for nozzle: N3.
 This calculation is valid for nozzles that meet all the requirements of paragraph UG-36. Please check the Code carefully, especially for nozzles that are not isolated or do not meet Code spacing requirements. To force the computation of areas for small nozzles go to Tools->Configuration and check the box to force the UG-37 small nozzle area calculation or force the Appendix 1-10 computation in Nozzle Design Options.*

UG-45 Minimum Nozzle Neck Thickness Requirement: [Int. Press.]

Wall Thickness for Internal/External pressures	ta	= 3.4164	mm
Wall Thickness per UG16(b),	tr16b	= 4.5000	mm
Wall Thickness, shell/head, internal pressure	trb1	= 5.9104	mm
Wall Thickness	tb1 = max(trb1, tr16b)	= 5.9104	mm
Wall Thickness	tb2 = max(trb2, tr16b)	= 4.5000	mm
Wall Thickness per table UG-45	tb3	= 6.1200	mm

Determine Nozzle Thickness candidate [tb]:

$$= \min[tb3, \max(tb1, tb2)]$$

$$= \min[6.12, \max(5.91, 4.5)]$$

$$= 5.9104 \text{ mm}$$

Minimum Wall Thickness of Nozzle Necks [tUG-45]:

$$= \max(ta, tb)$$

$$= \max(3.416, 5.91)$$

$$= 5.9104 \text{ mm}$$

Available Nozzle Neck Thickness = 8.3820 mm --> OK

Nozzle Junction Minimum Design Metal Temperature (MDMT) Calculations:

Nozzle-Shell/Head Weld (UCS-66(a)1(b)), Curve: B

Govrn. thk, tg = 8.11, tr = 2.91, c = 3 mm, E* = 1
 Thickness Ratio = tr * (E*) / (tg - c) = 0.57, Temp. Reduction = 25 °C

Min Metal Temp. w/o impact per UCS-66, Curve B	-29 °C
Min Metal Temp. at Required thickness (UCS 66.1)	-48 °C

Gov. MDMT of the nozzle to shell joint welded assembly : -48 °C

Weld Size Calculations, Description: N3

Intermediate Calc. for nozzle/shell Welds Tmin 5.3820 mm

Results Per UW-16.1:

	Required Thickness	Actual Thickness
Nozzle Weld	$3.7674 = 0.7 * t_{min}$	$4.2420 = 0.7 * W_o$ mm

Skipping the nozzle attachment weld strength calculations.
Per UW-15(b)(2) the nozzles exempted by UG-36(c)(3)(a)
(small nozzles) do not require a weld strength check.

Maximum Allowable Pressure for this Nozzle at this Location:

Converged Max. Allow. Pressure in Operating case 3.809 N/mm²

Note: The MAWP of this junction was limited by the parent Shell/Head.

The Drop for this Nozzle is : 1.4343 mm

The Cut Length for this Nozzle is, Drop + Ho + H + T : 57.1692 mm

PV Elite is a trademark of Hexagon AB, 2021, All rights reserved.

Report – 2nd-stage Suction_LI4735

PV-Elite Calculation Summary

Client: Airpack Nederland BV.
Client location: Zierikzee
Ref number client: 17811-OO-0702(KP)

PPV Engineering

Author: H.Hoezen
- Telephone: +31 (0)594 581010
- E-mail: h.hoezen@ppv-engineering.nl

April 19, 2022
Order number: P22-115-01
Document number: 22-11501-C04
Revision: 0

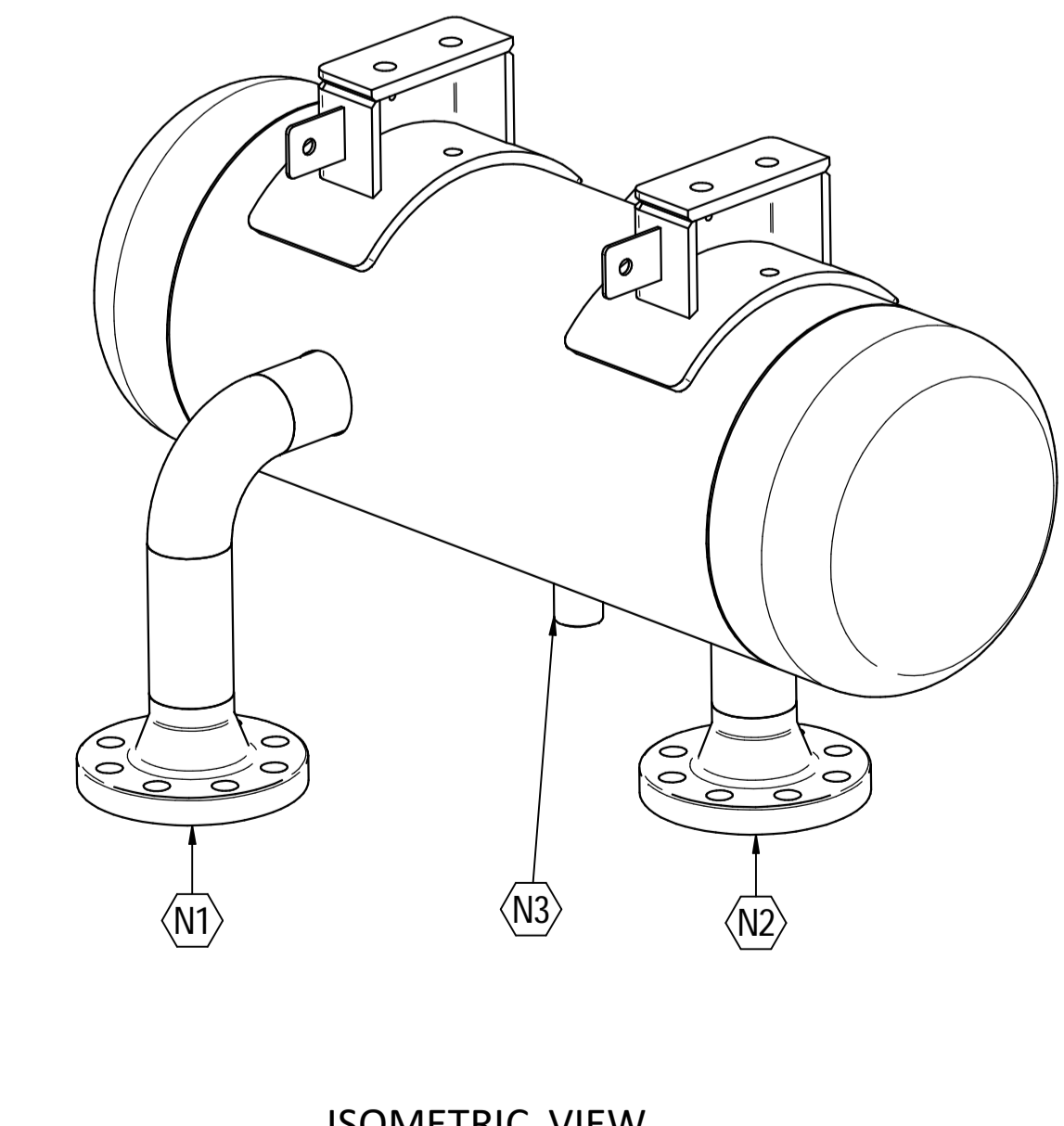
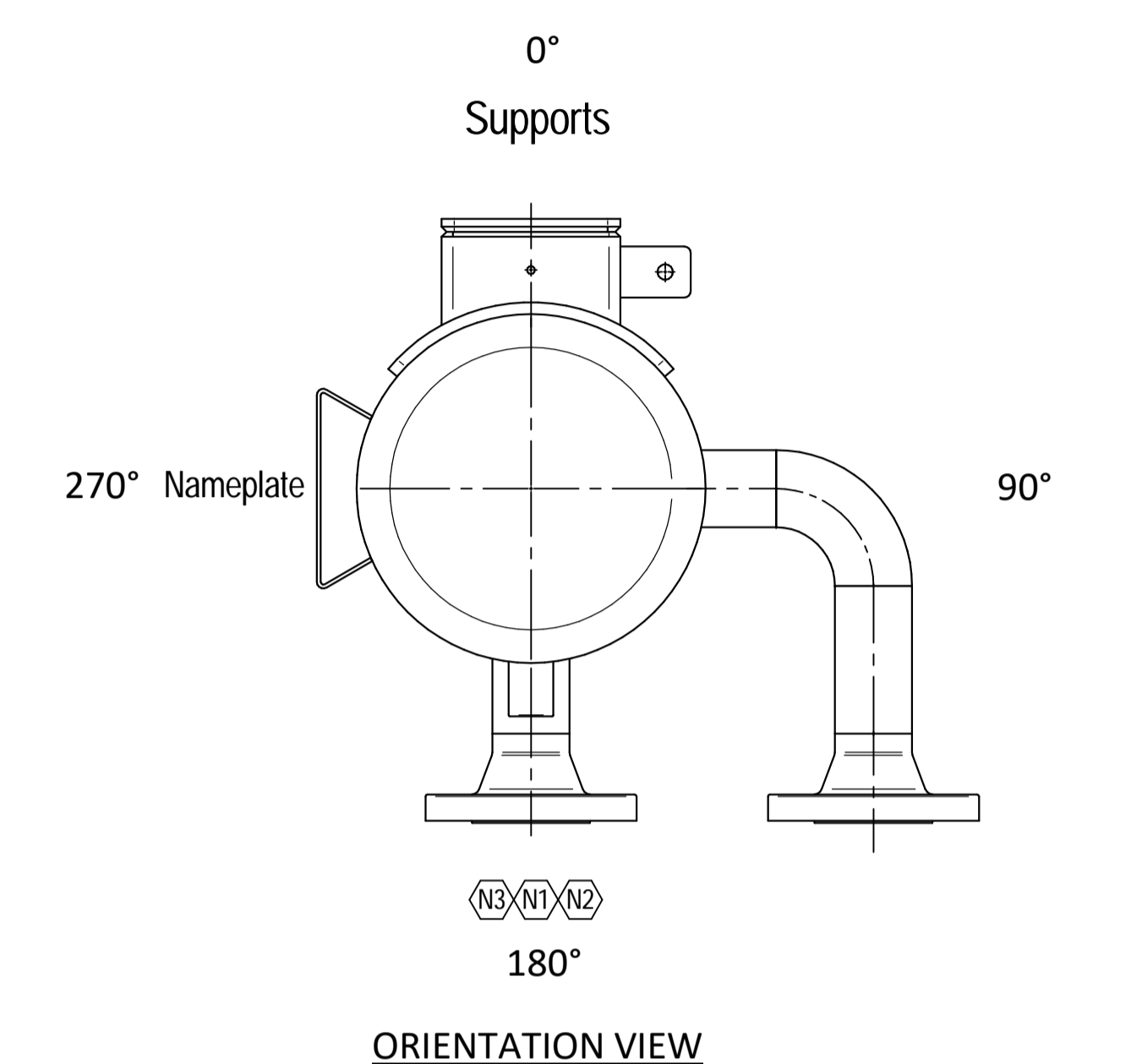
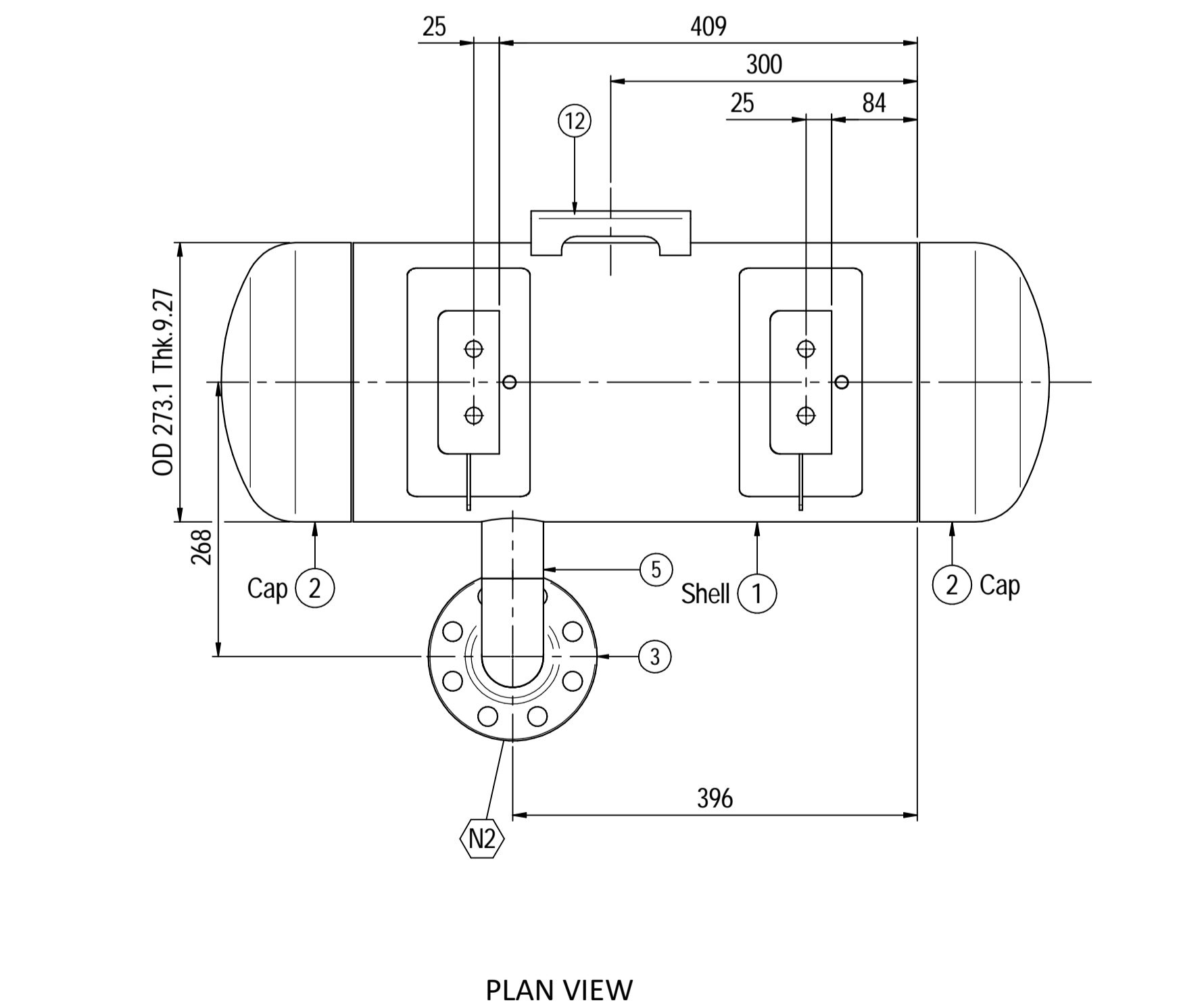
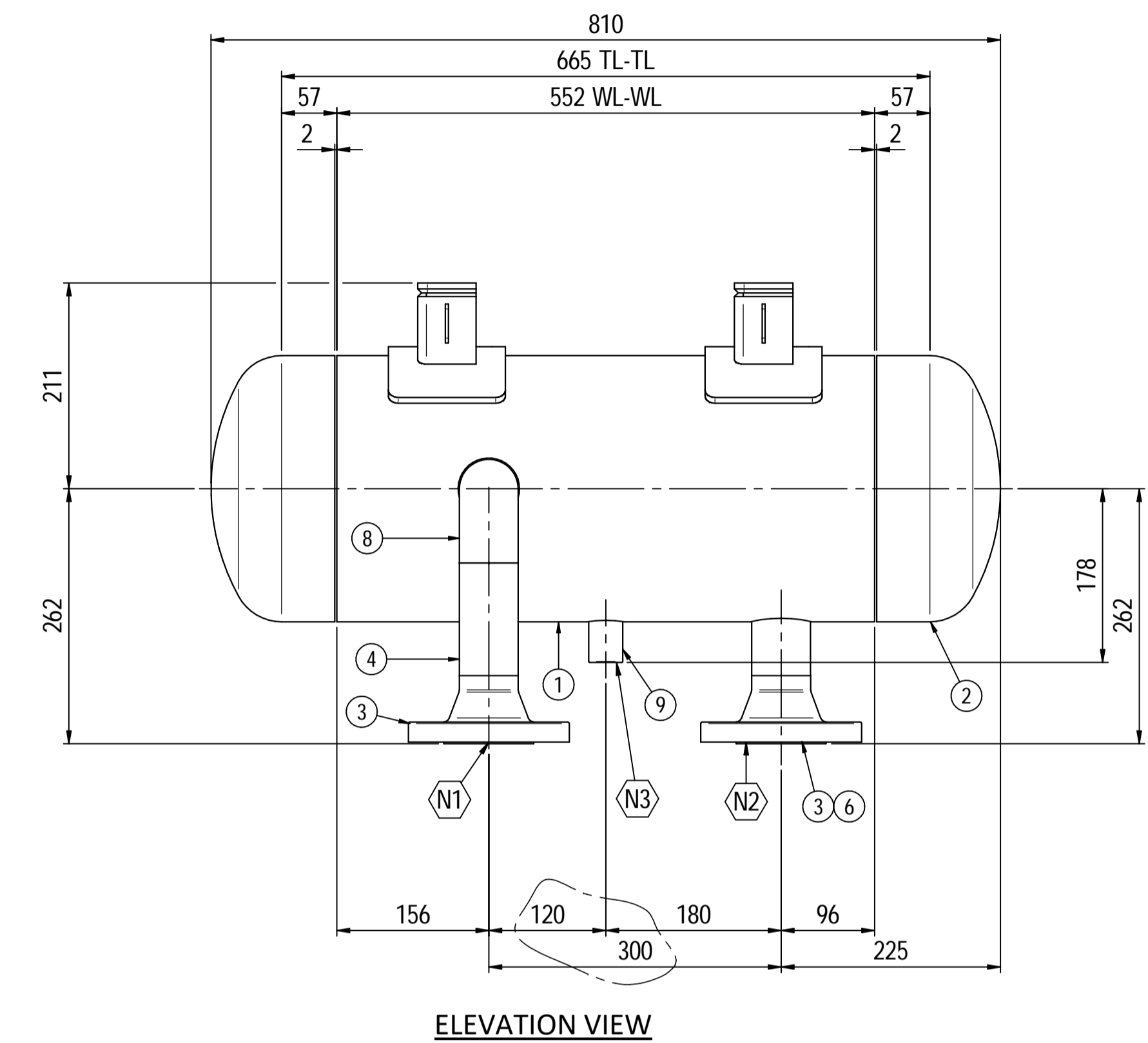
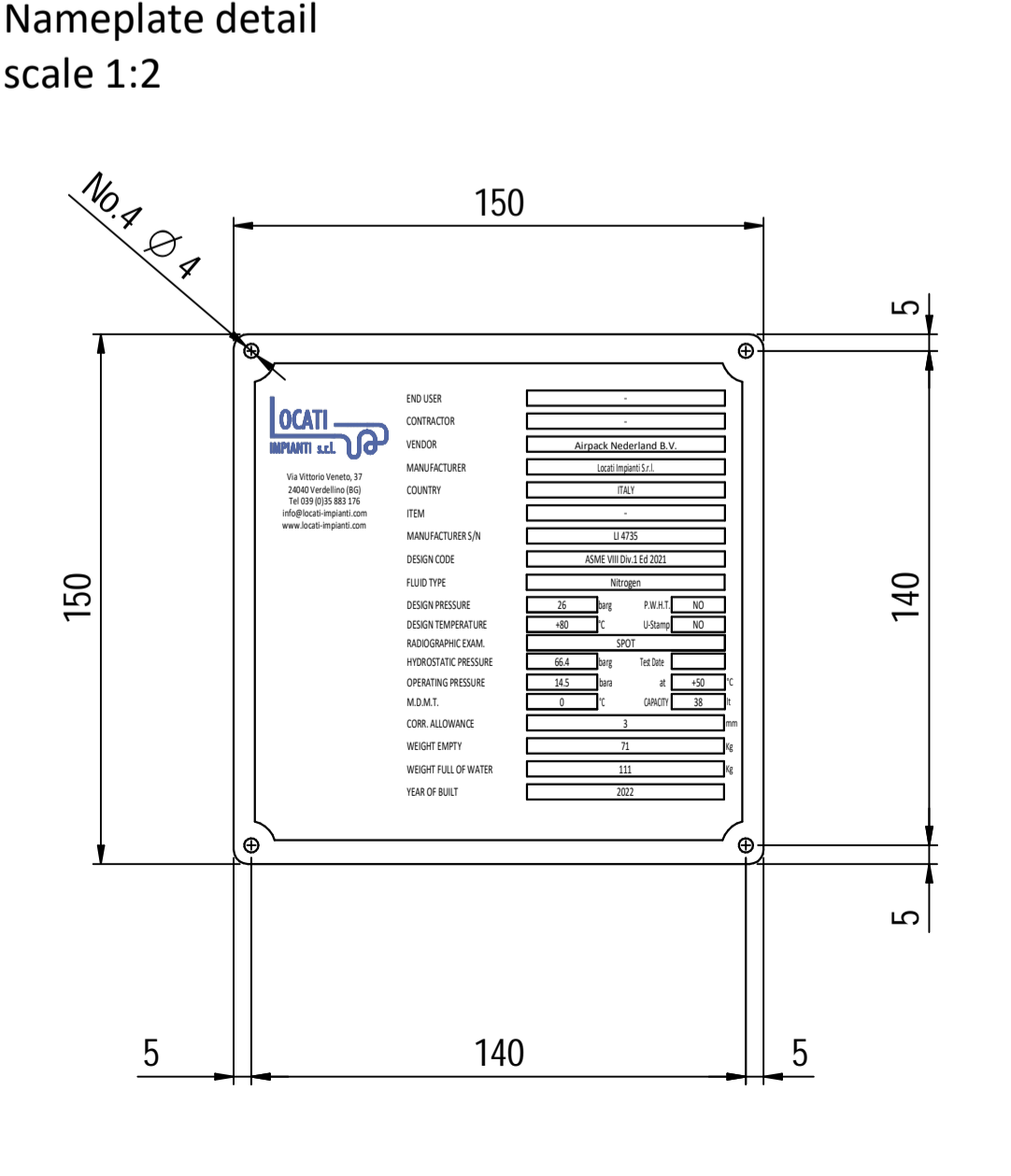
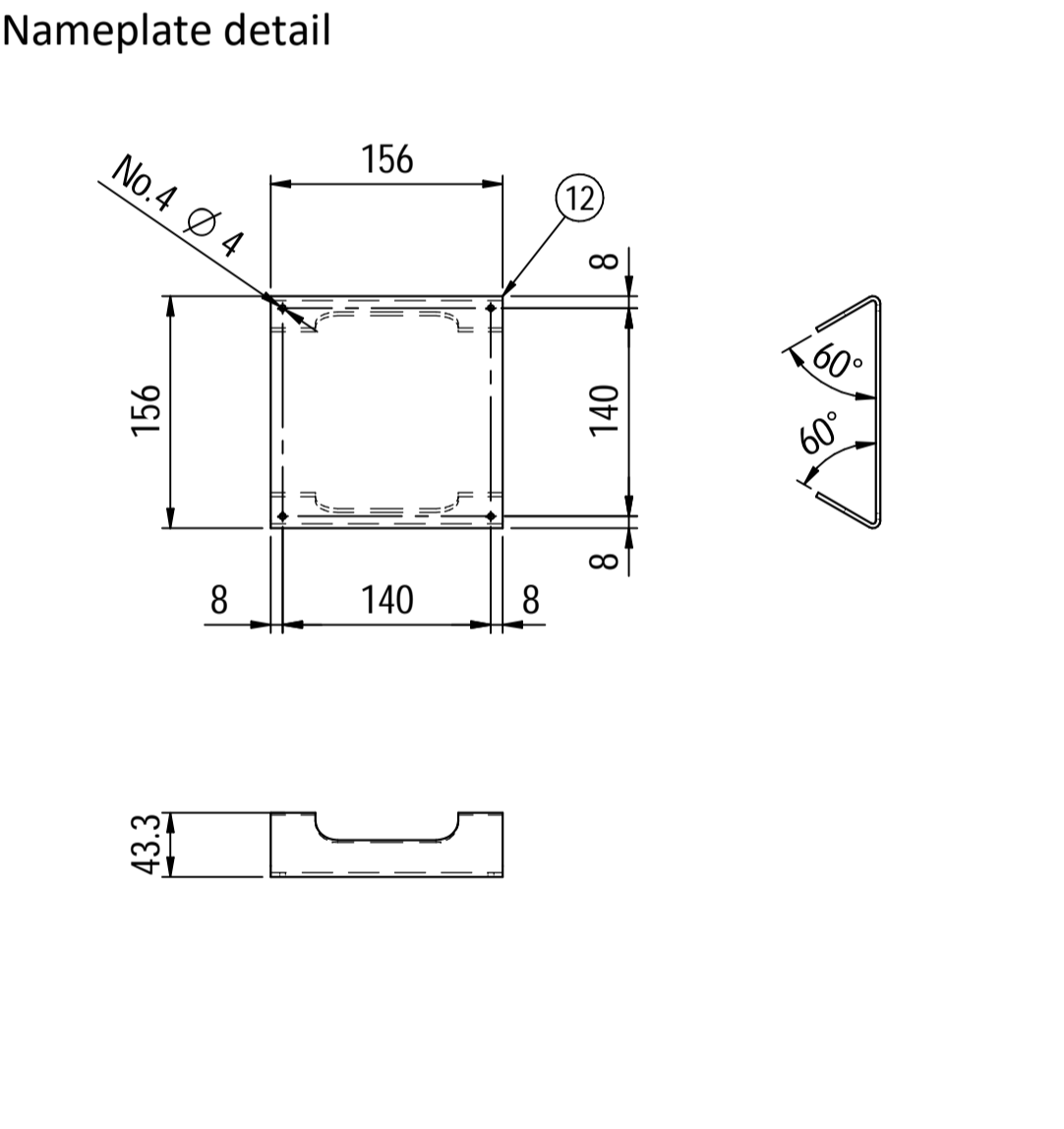
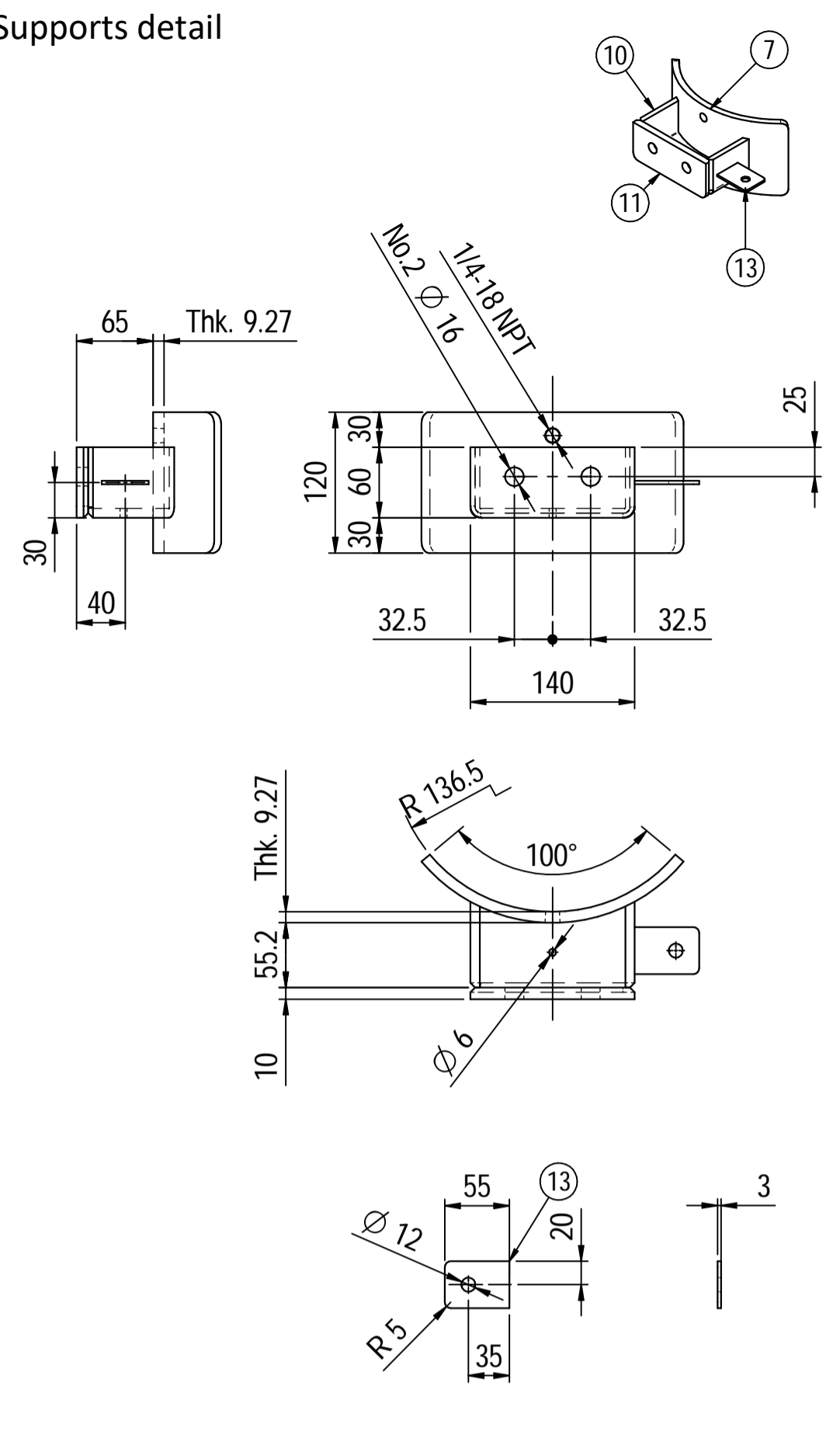

Material List					
Pos.	Q.ty	Description	Mat.	Cert.	
1	1	Shell by seamless pipe 10" Sch.STD L=552	SA106 Gr.B	3.1	
2	2	Cap 10" Sch40	A234 WPB	3.1	
3	2	Flange 2" WN #300 RF Sch.160	A105	3.1	
4	1	Seamless pipe 2" Sch160 L=115.5	A106 GrB	3.1	
5	1	Seamless pipe 2" Sch160 L=69	A106 GrB	3.1	
6	1	Seamless pipe 2" Sch160 L=68	A106 GrB	3.1	
7	2	Pad by pipe 10" Sch.STD	A106 Gr.B	3.1	
8	1	Seamless elbow 2" 90° LR Sch160	A234 WPB	3.1	
9	1	Coupling 1/2" NPT #6000	A105	3.1	
10	2	Plate 74.5x231 Thk.8	A516 70	3.1	
11	2	Plate 16x65 Thk.10	A516 70	3.1	
12	1	Nameplate support 156x241 Thk.3mm	A516 70	3.1	
13	2	Earthing Plate 55 x 40 Thk.3	A240 TP316L	3.1	

Note:
 1) Governing measurement S.I. unless otherwise specified;
 2) Flange bolt holes have to be straddled from main vessel center line in plan & vertical & horizontal centreline in elevation;
 3) Material: certification 3.1 EN 10204;
 4) All internal edge shall be rounded off;
 5) Nozzle flanges in accordance with ASME B16.5: 2013;
 6) Flange fittings in accordance with ASME B16.9: 2012;
 7) The flange dimensions are in accordance with ASME B16.5: 2013;
 8) All fillet welds not detailed on "WELDING MAP" or drawing shall have the weld; throated equal to 0,7 times the minimum thickness to be welded;
 9) All welds are continuous except where indicate;
 10) See document C220006CLC011 for vessel calculation.

ITEM	QTY	SERVICE	SIZE	O.D.	THK	RATING	TYPE	FACE	O.D.	THK.	Tc
N3	1	DRAIN	1/2"	38.1	8.38	#6000	-	NPT-F	-	-	8.5 ± 10
N2	1	AIR OUTLET	2"	60.3	8.74	#300	WN	RF	-	-	8.5 ± 10
N1	1	AIR INLET	2"	60.3	8.74	#300	WN	RF	-	-	8.5 ± 10

DATI DI PROGETTO / Design data			
FLUIDO	Nitrogen	COLLAUDO	Test
STATO FISICO DEL FLUIDO	Gas	NATIONAL BOARD REGISTRATION	NO
CODICE DI CALCOLO	ASME VIII Div. 1 Ed.2021	CANADIAN REGISTER NUMBER	NO
PRESSIONE DI ESERCIZIO	14.5 bara	SERVIZIO LETALE	NO
PRESSIONE DI PROGETTO	26 barg	X-RAY	RT examination
PRESSIONE ESTERNA	NO	LICUIDI PENETRANTI	NO
PRESSIONE DI PROVA IDRAULICA	66.4 barg	Dye penetrant extension	NO
TEMPERATURA DI ESERCIZIO	+50 °C	ULTRASUONI	NO
TEMPERATURA DI PROGETTO	+80 °C	Hydraulic test pressure	NO
SOVRAMETALLO DI CORROSIONE	3 mm	CONTROLLO MAGNETOSCOPICO	NO
CAPACITA'	38 l	MAGNETIC PARTICLE EXAMINATION	NO
EFFICIENZA GIUNTI	0.85	WELD TEST COUPON	NO
MAWP @ Design Temperature	38.12 bar @ +80 °C	PROCEDIMENTO DI SALDATURA	See doc: C220006WBK013
MAWP(EXT)	NO	Welding procedure	
MDMT @ MAWP	0 °C @ 38.12 bar	TIPO DI FONDO	CAP
TRATTAMENTO TERMICO	NO	Head type	
IMPACT TEST	NO	FORMAZIONE FONDO	HOT
		Head form	
		PESO A VUOTO	71 kg
		PESO IN ESERCIZIO	71 kg
		PESO PIENO D'ACQUA	111 kg
		Wind data	
		DATI SISMICI	
		Seismological data	

02	Modified as per Customer comments	CM	MV	GL	02/04/2022
01	Modified shell length	CM	MV	GL	30/03/2022
00	FIRST ISSUE	CM	MV	GL	16/03/2022
Rev.	Descrizione / Description	Disegnato/Draw	Controllato/Checked	Approvato/Approved	Data/Date
Oggetto/Object N2 PULSATION DAMPER 2nd STAGE SUCTION					
		Scala/Scale	1 : 5	Formato/Size	A1
		Comm. N°/Job No.	C220006	Foglio/Sheet	1 - 1
		Cliente/Customer	Airpack Nederland B.V.		
		Ord. No.	18498-VV-0901		
		Dis. N°/Dwg No.	C220006DWG005	Rev.	02

DESIGN CALCULATION

In Accordance with ASME Section VIII Division 1

ASME Code Version : 2019

Analysis Performed by : PPV-Engineering B.V.

Job File : P:\2_ENGINEERING\PROJ-2022\P22-115-AIRZI\01_PV E

Date of Analysis : Apr 13,2022 11:04am

PV Elite 23 SP2, October 2021

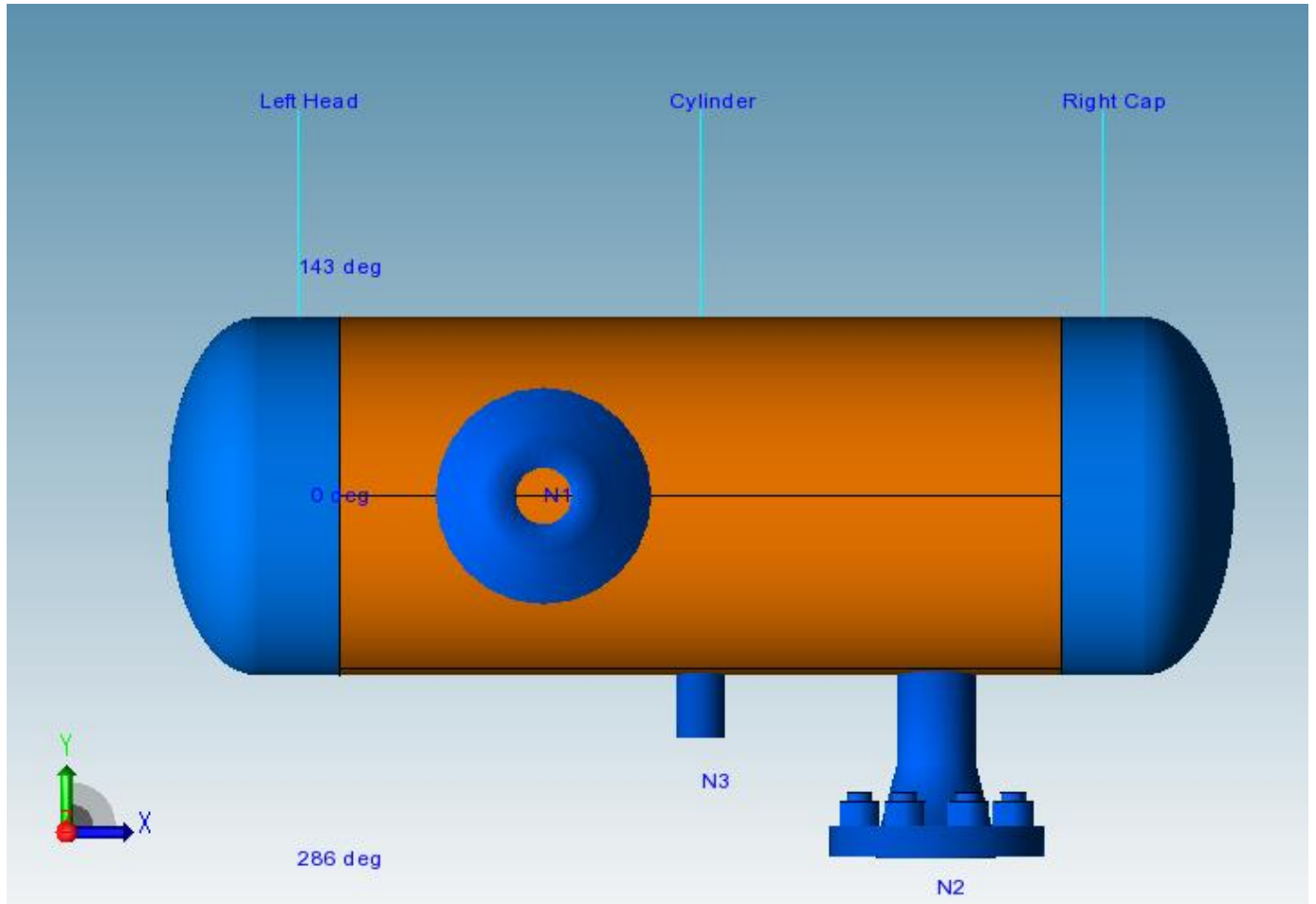

Table of Contents

Cover Sheet.....	2
Vessel Design Summary:.....	3
Nozzle Summary:	5
Nozzle Schedule:.....	6
Input Echo:.....	7
Internal Pressure Calculations:	11
Element and Detail Weights:.....	15
Nozzle Flange MAWP:.....	17
Nozzle Calcs.: N2	18
Nozzle Calcs.: N3	21
Nozzle Calcs.: N1	24

Vessel Design Summary:

ASME Code, Section VIII Division 1, 2019

Diameter Spec : 273.000 mm OD	
Vessel Design Length, Tangent to Tangent	678.72 mm
Specified Datum Line Distance	63.36 mm
Internal Design Temperature	80 °C
Internal Design Pressure	2.600 N/mm ²
External Design Temperature	80 °C
Maximum Allowable Working Pressure	3.809 N/mm ²
Shop Test Pressure	6.640 N/mm ²
Required Minimum Design Metal Temperature	-28.9 °C
Warmest Computed Minimum Design Metal Temperature	-46.0 °C
Wind Design Code	No Wind Loads
Earthquake Design Code	No Seismic

Materials of Construction:

Component Type	Material	Class	Thickness	UNS #	Normal ized	Impact Tested
Shell	SA-106 B	K03006	No	No
Head	SA-234 WPB	K03006	No	No
Nozzle	SA-106 B	K03006	No	No
Nozzle Flg	SA-105	K03504	No	No

Normalized is determined based on the UCS-66 material curve selection and Figure UCS-66.
 Impact Tested is based on material selection and material data properties.

Element Pressures and MAWP (N/mm² & mm):

Element Description or Type	Design Pressure + Stat. head	Ext. Press.	Element M.A.W.P	Total Corrosion Allowance	Str. Flg. Gov.	In Creep Range
Left Head	2.600	0.00	4.689	3.0000	Yes	No
Cylinder	2.600	0.00	3.809	3.0000	N/A	No
Right Cap	2.600	0.00	4.689	3.0000	Yes	No

Element Types and Properties:

Element Type	"To" Elev mm	Element Length mm	Nominal Thickness mm	Finished Thickness mm	Reqd Thk Internal mm	Reqd Thk External mm	Long Eff	Circ Eff
Ellipse	0.0	63.4	9.3	9.3	6.4	4.5	0.85	0.85
Cylinder	552.0	552.0	9.3	8.1	6.5	...	0.85	0.85
Ellipse	615.4	63.4	9.3	9.3	6.4	4.5	0.85	0.85

PV Elite 23 SP2 Licensee: PPV-Engineering B.V.

FileName : 2nd-stage Suction_LI4735 -----

Vessel Design Summary: Step: 15 11:04am Apr 13,2022

Weights:

Fabricated - Bare W/O Removable Internals	63.3	kgm
Shop Test - Fabricated + Water (Full)	102.6	kgm
Shipping - Fab. + Rem. Intls.+ Shipping App.	63.3	kgm
Erected - Fab. + Rem. Intls.+ Insul. (etc)	63.3	kgm
Empty - Fab. + Intls. + Details + Wghts.	63.3	kgm
Operating - Empty + Operating Liquid (No CA)	63.3	kgm
Field Test - Empty Weight + Water (Full)	102.6	kgm

PV Elite is a trademark of Hexagon AB, 2021, All rights reserved.

Nozzle Calculation Summary:

Description	MAWP N/mm ²	Ext	MAPNC N/mm ²	UG-45	[tr] mm	Weld Path	Areas or Stresses
N2	3.809	OK	5.91	OK	No Calc[*]
N3	3.809	OK	5.91	OK	No Calc[*]
N1	3.809	OK	5.91	OK	No Calc[*]

Nozzle MAWP Summary:

Minimum MAWP Nozzles : 3.809 Nozzle : N1
 Minimum MAWP Shells/Flanges : 3.809 Element : Cylinder
 Minimum MAPnc Shells/Flanges : 5.11 Element : Cylinder

 Computed Vessel M.A.W.P. : 3.809 N/mm²

[*] - This was a small opening and the areas were not computed.

Note: MAWPs (Internal Case) shown above are at the High Point.

Check the Spatial Relationship between the Nozzles:

From Node	Nozzle Description	X Coordinate mm	Layout Angle deg	Dia. Limit mm
20	N2	519.360	270.000	97.700
20	N3	339.360	270.000	54.672
20	N1	219.360	0.000	97.700

The nozzle spacing is computed by the following:

= Sqrt(ll² + lc²) where

ll - Arc length along the inside vessel surface in the long. direction.

lc - Arc length along the inside vessel surface in the circ. direction

If any interferences/violations are found, they will be noted below.

No interference violations have been detected!

PV Elite is a trademark of Hexagon AB, 2021, All rights reserved.

Nozzle Schedule:

Description	Nominal or Actual Size	Schd or FVC Type	Flg Type	Nozzle O/Dia mm	Wall Thk mm	Reinforcing Diameter	Pad Thk mm	Cut Length mm	Flg Class
N3	38 mm Actual		Non	38.1	8.4	5	...
N2	50 mm	160	WN	60.3	8.7	7	300
N1	50 mm	160	WN	60.3	8.7	6	...

General Notes for the above table:

The Cut Length is the Outside Projection + Inside Projection + Drop + In Plane Shell Thickness. This value does not include weld gaps, nor does it account for shrinkage.

In the case of Oblique Nozzles, the Outside Diameter must be increased. The Re-Pad WIDTH around the nozzle is calculated as follows:
Width of Pad = (Pad Outside Dia. (per above) - Nozzle Outside Dia.)/2

For hub nozzles, the thickness and diameter shown are those of the smaller and thinner section.

Nozzle Material and Weld Fillet Leg Size Details (mm):

Description	Material	Shl Grve Weld	Noz Shl/Pad Weld	Pad OD Weld	Pad Grve Weld	Inside Weld
N3	SA-106 B	8.340	6.000
N2	SA-106 B	8.340	6.000
N1	SA-106 B	8.340	6.000

Note: The Outside projections below do not include the flange thickness.

Nozzle Miscellaneous Data:

Description	Elev/Distance From Datum mm	Layout Angle deg	Proj Outside mm	Proj Inside mm	Installed in Component
N3	276.000	270.0	47.62	0.00	Cylinder
N2	456.000	270.0	68.00	0.00	Cylinder
N1	156.000	0.0	57.00	0.00	Cylinder

PV Elite is a trademark of Hexagon AB, 2021, All rights reserved.

Bill of Materials:

QTY	DESCRIPTION	MATERIAL
2	ELLIPTICAL HEAD: 2.0 X 1, 9.3mm THK X 254.5mm ID X 63.4mm	SA-234 WPB
2	CYLINDRICAL SEGMENT 9.3mm THK X 320.4mm X 552.0mm	SA-106 B
1	CYLINDRICAL SEGMENT 9.3mm THK X 165.8mm X 552.0mm	SA-106 B
1	NAMEPLATE	...

PV Elite is a trademark of Hexagon AB, 2021, All rights reserved.

PV Elite Vessel Analysis Program: Input Data

Design Internal Pressure (for Hydrotest)	2.6	N/mm ²
Design Internal Temperature	80.0	°C
Projection of Nozzle from Vessel Top	0	mm
Projection of Nozzle from Vessel Bottom	0	mm
Minimum Design Metal Temperature	-28.9	°C
Type of Construction	Welded	
Special Service	None	
Degree of Radiography	RT-3	
Use Higher Longitudinal Stresses (Flag)	Y	
Select t for Internal Pressure (Flag)	N	
Select t for External Pressure (Flag)	N	
Select t for Axial Stress (Flag)	N	
Select Location for Stiff. Rings (Flag)	N	
Consider Vortex Shedding	N	
Perform a Corroded Hydrotest	N	

Shop Pressure Test:

Type of Pressure Test	User Entered Pressure
Pressure Test Position	Horizontal

Load Case 1	NP+EW+WI+FW+BW
Load Case 2	NP+EW+EE+FS+BS
Load Case 3	NP+OW+WI+FW+BW
Load Case 4	NP+OW+EQ+FS+BS
Load Case 5	NP+HW+HI
Load Case 6	NP+HW+HE
Load Case 7	IP+OW+WI+FW+BW
Load Case 8	IP+OW+EQ+FS+BS
Load Case 9	EP+OW+WI+FW+BW
Load Case 10	EP+OW+EQ+FS+BS
Load Case 11	HP+HW+HI
Load Case 12	HP+HW+HE
Load Case 13	IP+WE+EW
Load Case 14	IP+WF+CW
Load Case 15	IP+VO+OW
Load Case 16	IP+VE+EW
Load Case 17	NP+VO+OW
Load Case 18	FS+BS+IP+OW
Load Case 19	FS+BS+EP+OW

Wind Design Code No Wind Loads

Seismic Design Code No Seismic

Design Pressure + Static Head	Y
Consider MAP New and Cold in Noz. Design	N
Consider External Loads for Nozzle Des.	Y
Use ASME VIII-1 Appendix 1-9	N

Material Database Year Current w/Addenda or Code Year

Configuration Directives:

Do not use Nozzle MDMT Interpretation VIII-1 01-37	No
Use Table G instead of exact equation for "A"	Yes
Shell Head Joints are Tapered	Yes
Compute "K" in corroded condition	Yes
Use Code Case 2286	No
Use the MAWP to compute the MDMT	Yes
For thickness ratios <= 0.35, MDMT will be -155F (-104C)	Yes
For PWHT & P1 Materials the MDMT can be < -55F (-48C)	No

FileName : 2nd-stage Suction_LI4735 -----

Input Echo: Step: 1 11:04am Apr 13,2022

Using Metric Material Databases, ASME II D No
 Calculate B31.3 type stress for Nozzles with Loads Yes
 Reduce the MDMT due to lower membrane stress Yes
 Consider Longitudinal Stress in MDMT calcs. (Div. 1) Yes

Complete Listing of Vessel Elements and Details:

Element From Node 10
 Element To Node 20
 Element Type Elliptical
 Description Left Head
 Distance "FROM" to "TO" 63.36 mm
 Element Outside Diameter 273 mm
 Element Thickness 9.27 mm
 Internal Corrosion Allowance 3 mm
 Nominal Thickness 9.27 mm
 External Corrosion Allowance 0 mm
 Design Internal Pressure 2.6 N/mm²
 Design Temperature Internal Pressure 80 °C
 Design External Pressure 0 N/mm²
 Design Temperature External Pressure 80 °C
 Effective Diameter Multiplier 1.2
 Material Name SA-234 WPB
 Allowable Stress, Ambient 117.9 N/mm²
 Allowable Stress, Operating 117.9 N/mm²
 Allowable Stress, Hydrotest 153.27 N/mm²
 Material Density 7750.4 kg/m³
 P Number Thickness 30.988 mm
 Yield Stress, Operating 223.97 N/mm²
 UCS-66 Chart Curve Designation B
 External Pressure Chart Name CS-2
 UNS Number K03006
 Product Form Smls. & wld. fittings
 Efficiency, Longitudinal Seam 0.85
 Efficiency, Circumferential Seam 0.85
 Elliptical Head Factor 2.0
 Weld is pre-Heated No

 Element From Node 20
 Element To Node 30
 Element Type Cylinder
 Description Cylinder
 Distance "FROM" to "TO" 552 mm
 Element Outside Diameter 273 mm
 Element Thickness 8.11 mm
 Internal Corrosion Allowance 3 mm
 Nominal Thickness 9.27 mm
 External Corrosion Allowance 0 mm
 Design Internal Pressure 2.6 N/mm²
 Design Temperature Internal Pressure 80 °C
 Design External Pressure 0 N/mm²
 Design Temperature External Pressure 80 °C
 Effective Diameter Multiplier 1.2
 Material Name SA-106 B
 Allowable Stress, Ambient 117.9 N/mm²
 Allowable Stress, Operating 117.9 N/mm²
 Allowable Stress, Hydrotest 153.27 N/mm²
 Material Density 7750.4 kg/m³
 P Number Thickness 30.988 mm
 Yield Stress, Operating 223.97 N/mm²
 UCS-66 Chart Curve Designation B
 External Pressure Chart Name CS-2

FileName : 2nd-stage Suction_LI4735 -----

Input Echo: Step: 1 11:04am Apr 13,2022

UNS Number	K03006	
Product Form	Smls. pipe	
Efficiency, Longitudinal Seam	0.85	
Efficiency, Circumferential Seam	0.85	
Weld is pre-Heated	No	
Element From Node	20	
Detail Type	Nozzle	
Detail ID	N2	
Dist. from "FROM" Node / Offset dist	456	mm
Nozzle Diameter	50	mm
Nozzle Schedule	160	
Nozzle Class	300	
Layout Angle	270.0	
Blind Flange (Y/N)	N	
Weight of Nozzle (Used if > 0)	0	N
Grade of Attached Flange	GR 1.1	
Nozzle Matl	SA-106 B	
Element From Node	20	
Detail Type	Nozzle	
Detail ID	N3	
Dist. from "FROM" Node / Offset dist	276	mm
Nozzle Diameter	38.1	mm
Nozzle Schedule	None	
Nozzle Class	None	
Layout Angle	270.0	
Blind Flange (Y/N)	N	
Weight of Nozzle (Used if > 0)	0	N
Grade of Attached Flange	None	
Nozzle Matl	SA-106 B	
Element From Node	20	
Detail Type	Nozzle	
Detail ID	N1	
Dist. from "FROM" Node / Offset dist	156	mm
Nozzle Diameter	50	mm
Nozzle Schedule	160	
Nozzle Class	300	
Layout Angle	0.0	
Blind Flange (Y/N)	N	
Weight of Nozzle (Used if > 0)	0	N
Grade of Attached Flange	None	
Nozzle Matl	SA-106 B	

PV Elite 23 SP2 Licensee: PPV-Engineering B.V.

FileName : 2nd-stage Suction_LI4735 -----

Input Echo: Step: 1 11:04am Apr 13,2022

Element From Node	30	
Element To Node	40	
Element Type	Elliptical	
Description	Right Cap	
Distance "FROM" to "TO"	63.36	mm
Element Outside Diameter	273	mm
Element Thickness	9.27	mm
Internal Corrosion Allowance	3	mm
Nominal Thickness	9.27	mm
External Corrosion Allowance	0	mm
Design Internal Pressure	2.6	N/mm ²
Design Temperature Internal Pressure	80	°C
Design External Pressure	0	N/mm ²
Design Temperature External Pressure	80	°C
Effective Diameter Multiplier	1.2	
Material Name	SA-234 WPB	
Allowable Stress, Ambient	117.9	N/mm ²
Allowable Stress, Operating	117.9	N/mm ²
Allowable Stress, Hydrotest	153.27	N/mm ²
Material Density	7750.4	kg/m ³
P Number Thickness	30.988	mm
Yield Stress, Operating	223.97	N/mm ²
UCS-66 Chart Curve Designation	B	
External Pressure Chart Name	CS-2	
UNS Number	K03006	
Product Form	Smls. & wld. fittings	
Efficiency, Longitudinal Seam	0.85	
Efficiency, Circumferential Seam	0.85	
Elliptical Head Factor	2.0	
Weld is pre-Heated	No	

PV Elite is a trademark of Hexagon AB, 2021, All rights reserved.

Internal Pressure Results Summary:

Element Thickness, Pressure, Diameter and Allowable Stress :

From	To	Int. Press + Liq. Hd N/mm ²	Nominal Thickness mm	Total Corr Allowance mm	Element Diameter mm	Allowable Stress (SE) N/mm ²
Left Head		2.6	9.27	3	273	100.22
Cylinder		2.6	9.27	3	273	100.22
Right Cap		2.6	9.27	3	273	100.22

Element Required Thickness and MAWP :

From	To	Design Pressure N/mm ²	M.A.W.P. Corroded N/mm ²	M.A.P. New & Cold N/mm ²	Minimum Thickness mm	Required Thickness mm
Left Head		2.6	4.689	7.249	9.27	6.36037
Cylinder		2.6	3.809	6.099	8.11	6.505
Right Cap		2.6	4.689	7.249	9.27	6.36037
Minimum			3.809	5.11		

Note : The M.A.P.(NC) is Governed by a Flange !

MAWP: 3.809 N/mm², limited by: Cylinder.

Elements Suitable for Design Internal Pressure.

Internal Pressure Calculation Results:

ASME Code, Section VIII Division 1, 2019

Elliptical Head From 10 To 20 SA-234 WPB , UCS-66 Crv. B at 80 °C

Left Head

Material UNS Number: K03006

Required Thickness due to Internal Pressure [tr]:

$$= (P \cdot Do \cdot K_{cor}) / (2 \cdot S \cdot E + 2 \cdot P \cdot (K_{cor} - 0.1)) \text{ per Appendix 1-4 (c)}$$

$$= (2.6 \cdot 273 \cdot 0.97) / (2 \cdot 117.9 \cdot 0.85 + 2 \cdot 2.6 \cdot (0.97 - 0.1))$$

$$= 3.3604 + 3.0000 = 6.3604 \text{ mm}$$

Max. Allowable Working Pressure at given Thickness, corroded [MAWP]:

$$= (2 \cdot S \cdot E \cdot t) / (K_{cor} \cdot Do - 2 \cdot t \cdot (K_{cor} - 0.1)) \text{ per Appendix 1-4 (c)}$$

$$= (2 \cdot 117.9 \cdot 0.85 \cdot 6.27) / (0.97 \cdot 273 - 2 \cdot 6.27 \cdot (0.97 - 0.1))$$

$$= 4.948 \text{ N/mm}^2$$

Maximum Allowable Pressure, New and Cold [MAPNC]:

$$= (2 \cdot S \cdot E \cdot t) / (K \cdot Do - 2 \cdot t \cdot (K - 0.1)) \text{ per Appendix 1-4 (c)}$$

$$= (2 \cdot 117.9 \cdot 0.85 \cdot 9.27) / (1 \cdot 273 - 2 \cdot 9.27 \cdot (1 - 0.1))$$

$$= 7.249 \text{ N/mm}^2$$

Actual stress at given pressure and thickness, corroded [Sact]:

$$= (P \cdot (K_{cor} \cdot Do - 2 \cdot t \cdot (K_{cor} - 0.1))) / (2 \cdot E \cdot t)$$

$$= (2.6 \cdot (0.97 \cdot 273 - 2 \cdot 6.27 \cdot (0.97 - 0.1))) / (2 \cdot 0.85 \cdot 6.27)$$

$$= 61.953 \text{ N/mm}^2$$

Straight Flange Required Thickness:

$$= (P \cdot Ro) / (S \cdot E + 0.4 \cdot P) + ca \text{ per Appendix 1-1 (a) (1)}$$

$$= (2.6 \cdot 136.5) / (117.9 \cdot 0.85 + 0.4 \cdot 2.6) + 3$$

FileName : 2nd-stage Suction_LI4735 -----

Internal Pressure Calculations: Step: 3 11:04am Apr 13,2022

$$= 6.505 \text{ mm}$$

Straight Flange Maximum Allowable Working Pressure:

$$= (S \cdot E \cdot t) / (R_o - 0.4 \cdot t) \text{ per Appendix 1-1 (a) (1)}$$

$$= (117.9 \cdot 0.85 \cdot 6.27) / (136.5 - 0.4 \cdot 6.27)$$

$$= 4.689 \text{ N/mm}^2$$

Factor K, corroded condition [Kcor]:

$$= (2 + (\text{Inside Diameter} / (2 \cdot \text{Inside Head Depth}))^2) / 6$$

$$= (2 + (260.5 / (2 \cdot 66.61))^2) / 6$$

$$= 0.970315$$

MDMT Calculations in the Knuckle Portion:

Govrn. thk, $t_g = 9.27$, $t_r = 4.873$, $c = 3$ mm, $E^* = 0.85$
 Thickness Ratio = $t_r \cdot (E^*) / (t_g - c) = 0.661$, Temp. Reduction = 19 °C

Min Metal Temp. w/o impact per UCS-66, Curve B -29 °C
 Min Metal Temp. at Required thickness (UCS 66.1) -48 °C

MDMT Calculations in the Head Straight Flange:

Govrn. thk, $t_g = 9.27$, $t_r = 5.11$, $c = 3$ mm, $E^* = 0.85$
 Thickness Ratio = $t_r \cdot (E^*) / (t_g - c) = 0.693$, Temp. Reduction = 17 °C

Min Metal Temp. w/o impact per UCS-66, Curve B -29 °C
 Min Metal Temp. at Required thickness (UCS 66.1) -46 °C

Cylindrical Shell From 20 To 30 SA-106 B, UCS-66 Crv. B at 80 °C

Cylinder

Longitudinal Joint: Seamless

Material UNS Number: K03006

Required Thickness due to Internal Pressure [tr]:

$$= (P \cdot R_o) / (S \cdot E + 0.4 \cdot P) \text{ per Appendix 1-1 (a) (1)}$$

$$= (2.6 \cdot 136.5) / (117.9 \cdot 0.85 + 0.4 \cdot 2.6)$$

$$= 3.5050 + 3.0000 = 6.5050 \text{ mm}$$

Max. Allowable Working Pressure at given Thickness, corroded [MAWP]:

$$= (S \cdot E \cdot t) / (R_o - 0.4 \cdot t) \text{ per Appendix 1-1 (a) (1)}$$

$$= (117.9 \cdot 0.85 \cdot 5.11) / (136.5 - 0.4 \cdot 5.11)$$

$$= 3.809 \text{ N/mm}^2$$

Maximum Allowable Pressure, New and Cold [MAPNC]:

$$= (S \cdot E \cdot t) / (R_o - 0.4 \cdot t) \text{ per Appendix 1-1 (a) (1)}$$

$$= (117.9 \cdot 0.85 \cdot 8.11) / (136.5 - 0.4 \cdot 8.11)$$

$$= 6.099 \text{ N/mm}^2$$

Actual stress at given pressure and thickness, corroded [Sact]:

$$= (P \cdot (R_o - 0.4 \cdot t)) / (E \cdot t)$$

$$= (2.6 \cdot (136.5 - 0.4 \cdot 5.11)) / (0.85 \cdot 5.11)$$

$$= 80.485 \text{ N/mm}^2$$

Minimum Design Metal Temperature Results:

Govrn. thk, $t_g = 8.11$, $t_r = 2.478$, $c = 3$ mm, $E^* = 0.85$
 Thickness Ratio = $t_r \cdot (E^*) / (t_g - c) = 0.412$, Temp. Reduction = 48 °C

Min Metal Temp. w/o impact per UCS-66, Curve B -29 °C
 Min Metal Temp. at Required thickness (UCS 66.1) -48 °C

Elliptical Head From 30 To 40 SA-234 WPB , UCS-66 Crv. B at 80 °C

Right Cap

Material UNS Number: K03006

Required Thickness due to Internal Pressure [tr]:

$$= (P \cdot Do \cdot K_{cor}) / (2 \cdot S \cdot E + 2 \cdot P \cdot (K_{cor} - 0.1)) \text{ per Appendix 1-4 (c)}$$

$$= (2.6 \cdot 273 \cdot 0.97) / (2 \cdot 117.9 \cdot 0.85 + 2 \cdot 2.6 \cdot (0.97 - 0.1))$$

$$= 3.3604 + 3.0000 = 6.3604 \text{ mm}$$

Max. Allowable Working Pressure at given Thickness, corroded [MAWP]:

$$= (2 \cdot S \cdot E \cdot t) / (K_{cor} \cdot Do - 2 \cdot t \cdot (K_{cor} - 0.1)) \text{ per Appendix 1-4 (c)}$$

$$= (2 \cdot 117.9 \cdot 0.85 \cdot 6.27) / (0.97 \cdot 273 - 2 \cdot 6.27 \cdot (0.97 - 0.1))$$

$$= 4.948 \text{ N/mm}^2$$

Maximum Allowable Pressure, New and Cold [MAPNC]:

$$= (2 \cdot S \cdot E \cdot t) / (K \cdot Do - 2 \cdot t \cdot (K - 0.1)) \text{ per Appendix 1-4 (c)}$$

$$= (2 \cdot 117.9 \cdot 0.85 \cdot 9.27) / (1 \cdot 273 - 2 \cdot 9.27 \cdot (1 - 0.1))$$

$$= 7.249 \text{ N/mm}^2$$

Actual stress at given pressure and thickness, corroded [Sact]:

$$= (P \cdot (K_{cor} \cdot Do - 2 \cdot t \cdot (K_{cor} - 0.1))) / (2 \cdot E \cdot t)$$

$$= (2.6 \cdot (0.97 \cdot 273 - 2 \cdot 6.27 \cdot (0.97 - 0.1))) / (2 \cdot 0.85 \cdot 6.27)$$

$$= 61.953 \text{ N/mm}^2$$

Straight Flange Required Thickness:

$$= (P \cdot Ro) / (S \cdot E + 0.4 \cdot P) + ca \text{ per Appendix 1-1 (a) (1)}$$

$$= (2.6 \cdot 136.5) / (117.9 \cdot 0.85 + 0.4 \cdot 2.6) + 3$$

$$= 6.505 \text{ mm}$$

Straight Flange Maximum Allowable Working Pressure:

$$= (S \cdot E \cdot t) / (Ro - 0.4 \cdot t) \text{ per Appendix 1-1 (a) (1)}$$

$$= (117.9 \cdot 0.85 \cdot 6.27) / (136.5 - 0.4 \cdot 6.27)$$

$$= 4.689 \text{ N/mm}^2$$

Factor K, corroded condition [Kcor]:

$$= (2 + (\text{Inside Diameter} / (2 \cdot \text{Inside Head Depth}))^2) / 6$$

$$= (2 + (260.5 / (2 \cdot 66.61))^2) / 6$$

$$= 0.970315$$

MDMT Calculations in the Knuckle Portion:

Govrn. thk, tg = 9.27, tr = 4.873, c = 3 mm, E* = 0.85
 Thickness Ratio = tr * (E*) / (tg - c) = 0.661, Temp. Reduction = 19 °C

Min Metal Temp. w/o impact per UCS-66, Curve B -29 °C
 Min Metal Temp. at Required thickness (UCS 66.1) -48 °C

MDMT Calculations in the Head Straight Flange:

Govrn. thk, tg = 9.27, tr = 5.11, c = 3 mm, E* = 0.85
 Thickness Ratio = tr * (E*) / (tg - c) = 0.693, Temp. Reduction = 17 °C

Min Metal Temp. w/o impact per UCS-66, Curve B -29 °C
 Min Metal Temp. at Required thickness (UCS 66.1) -46 °C

Note: Heads and Shells Exempted to -20F (-29C) by paragraph UG-20F

Hydrostatic Test Pressure Results:

Pressure per UG99b	= 1.30 * M.A.W.P. * Sa/S	4.951	N/mm ²
Pressure per UG99b[35]	= 1.30 * Design Pres * Sa/S	3.380	N/mm ²
Pressure per UG99c	= 1.30 * M.A.P. - Head(Hyd)	6.643	N/mm ²

PV Elite 23 SP2 Licensee: PPV-Engineering B.V.

FileName : 2nd-stage Suction_LI4735 -----

Internal Pressure Calculations: Step: 3 11:04am Apr 13,2022

Pressure per UG100	= 1.10 * M.A.W.P. * Sa/S	4.190	N/mm ²
Pressure per PED	= max(1.43*DP, 1.25*DP*ratio)	3.718	N/mm ²
Pressure per App 27-4	= M.A.W.P.	3.809	N/mm ²
User Defined Hydrostatic Test Pressure at High Point		6.640	N/mm ²

Horizontal Test performed per: User Hydro Pressure

Please note that Nozzle, Shell, Head, Flange, etc MAWPs are all considered when determining the hydrotest pressure for those test types that are based on the MAWP of the vessel.

Stresses on Elements due to Test Pressure (N/mm²):

From To	Stress	Allowable	Ratio	Pressure
Left Head	108.0	153.3	0.705	6.64
Cylinder	128.4	153.3	0.838	6.64
Right Cap	108.0	153.3	0.705	6.64

Stress ratios for Nozzle and Pad Materials (N/mm²):

Description	Pad/Nozzle	Ambient	Operating	Ratio
N2	Nozzle	117.90	117.90	1.000
N3	Nozzle	117.90	117.90	1.000
N1	Nozzle	117.90	117.90	1.000
Minimum				1.000

Stress ratios for Pressurized Vessel Elements (N/mm²):

Description	Ambient	Operating	Ratio
Left Head	117.90	117.90	1.000
Cylinder	117.90	117.90	1.000
Right Cap	117.90	117.90	1.000
Minimum			1.000

Hoop Stress in Nozzle Wall during Pressure Test (N/mm²):

Description	Ambient	Operating	Ratio
N2	20.27	153.27	0.132
N3	12.44	153.27	0.081
N1	20.27	153.27	0.132

Elements Suitable for Test Pressure.

PV Elite is a trademark of Hexagon AB, 2021, All rights reserved.

PV Elite 23 SP2 Licensee: PPV-Engineering B.V.
 FileName : 2nd-stage Suction_LI4735 -----
 Element and Detail Weights: Step: 5 11:04am Apr 13,2022

Element and Detail Weights:

From	To	Element Metal Wgt. kgm	Element ID Volume m³	Corroded Metal Wgt. kgm	Corroded ID Volume m³	Extra due Misc %
10	20	9.75261	0.0053798	6.59643	0.0056898	...
20	30	33.1484	0.028591	22.6736	0.029943	...
30	40	9.75261	0.0053798	6.59643	0.0056898	...
Total		52	0.04	35	0.04	0

Weight of Details:

From	Type	Weight of Detail kgm	X Offset, Dtl. Cent. mm	Y Offset, Dtl. Cent. mm	Z Offset, Dtl. Cent. mm	Description
20	Noz1	5.24528	456	-158.553	...	N2
20	Noz1	0.28886	276	-147.44	...	N3
20	Noz1	5.12457	156	...	158.553	N1

Total Weight of Each Detail Type:

Nozzles	10.7

Sum of the Detail Weights	10.7 kgm

Weight Summation Results: (kgm)

	Fabricated	Shop Test	Shipping	Erected	Empty	Operating
Main Elements	52.7	52.7	52.7	52.7	52.7	52.7
Nozzles	10.7	10.7	10.7	10.7	10.7	10.7
Test Liquid	...	39.3
Totals	63.3	102.6	63.3	63.3	63.3	63.3

Weight Summary:

Fabricated Wt.	- Bare Weight without Removable Internals	63.3 kgm
Shop Test Wt.	- Fabricated Weight + Water (Full)	102.6 kgm
Shipping Wt.	- Fab. Weight + removable Intls.+ Shipping App.	63.3 kgm
Erected Wt.	- Fab. Wt + or - loose items (trays,platforms etc.)	63.3 kgm
Ope. Wt. no Liq	- Fab. Weight + Internals. + Details + Weights	63.3 kgm
Operating Wt.	- Empty Weight + Operating Liq. Uncorroded	63.3 kgm
Oper. Wt. + CA	- Corr Wt. + Operating Liquid	46.5 kgm
Field Test Wt.	- Empty Weight + Water (Full)	102.6 kgm

Note:
 The Corroded Weight and thickness are used in the Horizontal Vessel Analysis (Ope Case) and Earthquake Load Calculations.

PV Elite 23 SP2 Licensee: PPV-Engineering B.V.

FileName : 2nd-stage Suction_LI4735

Step: 5 11:04am Apr 13,2022

Element and Detail Weights:

Outside Surface Areas of Elements:

From	To	Surface Area cm ²
10	20	1351.29
20	30	4774.49
30	40	1351.29
Total		7477.075 cm ²

PV Elite is a trademark of Hexagon AB, 2021, All rights reserved.

FileName : 2nd-stage Suction_LI4735 -----

Nozzle Flange MAWP: Step: 6 11:04am Apr 13,2022

Nozzle Flange MAWP Results: (N/mm² & °C)

Nozzle Description	Flange Rating		Design Temp	Class	Grade/Group	Equiv. Press	UG-44(b)	Max Pressure	50%	DNV
N2	4.80	5.11	80	300	GR 1.1
Min Rating	4.800	5.110 N/mm ² [for Core Elements]					0.000	0.000	0.000	0.000

Pressure Ratings are per ASME B16.5 2013 Metric Edition

PV Elite is a trademark of Hexagon AB, 2021, All rights reserved.

Input, Nozzle Desc: N2 From: 20

Pressure for Reinforcement Calculations	P	2.6000	N/mm ²
Temperature for Internal Pressure	Temp	80	°C
Parent Material		SA-106 B	
Parent Allowable Stress at Temperature	Sv	117.90	N/mm ²
Parent Allowable Stress At Ambient	Sva	117.90	N/mm ²
Inside Diameter of Cylindrical Shell	D	254.46	mm
Shell Finished (Minimum) Thickness	t	8.1100	mm
Shell Internal Corrosion Allowance	c	3.0000	mm
Shell External Corrosion Allowance	co	0.0000	mm
Distance from Bottom/Left Tangent		519.36	mm
User Entered Minimum Design Metal Temperature		-28.89	°C

Type of Element Connected to the Parent : Nozzle

Material		SA-106 B	
Material UNS Number		K03006	
Material Specification/Type		Smls. pipe	
Allowable Stress at Temperature	Sn	117.90	N/mm ²
Allowable Stress At Ambient	Sna	117.90	N/mm ²
Diameter Basis (for tr calc only)		Outside	
Layout Angle		270.00	deg
Diameter		50.0000	mm
Size and Thickness Basis		Nominal	
Nominal Thickness		160	
Flange Material		SA-105	
Flange Type		Weld Neck Flange	
Corrosion Allowance	can	3.0000	mm
Joint Efficiency of Shell Seam at Nozzle	E1	1.00	
Joint Efficiency of Nozzle Neck	En	1.00	
Outside Projection	ho	68.0000	mm
Weld leg size between Nozzle and Pad/Shell	Wo	6.0000	mm
Groove weld depth between Nozzle and Vessel	Wgnv	8.3400	mm
Flange Class		300	
Flange Grade		GR 1.1	

The Pressure Design option was Design Pressure + static head.

Nozzle Sketch (may not represent actual weld type/configuration)

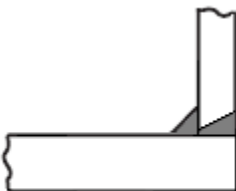

Abutting/Set-on Nozzle No Pad

Reinforcement CALCULATION, Description: N2

ASME Code, Section VIII, Div. 1, 2019, UG-37 to UG-45

Actual Outside Diameter Used in Calculation 60.325 mm.
 Actual Thickness Used in Calculation 8.738 mm

Nozzle input data check completed without errors.

Reqd thk per UG-37(a) of Cylindrical Shell, tr [Int. Press]

$$= P \cdot R / (S_v \cdot E - 0.6 \cdot P) \text{ per UG-27 (c) (1)}$$

$$= 2.6 \cdot 130.2 / (117.9 \cdot 1 - 0.6 \cdot 2.6)$$

$$= 2.9104 \text{ mm}$$

Reqd thk per UG-37(a) of Nozzle Wall, trn [Int. Press]

$$= P \cdot R_o / (S_n \cdot E + 0.4 \cdot P) \text{ per Appendix 1-1 (a) (1)}$$

$$= 2.6 \cdot 30.16 / (117.9 \cdot 1 + 0.4 \cdot 2.6)$$

$$= 0.6593 \text{ mm}$$

UG-40, Limits of Reinforcement : [Internal Pressure]

Parallel to Vessel Wall (Diameter Limit)	Dl	97.6996	mm
Parallel to Vessel Wall, opening length	d	48.8498	mm
Normal to Vessel Wall (Thickness Limit), no pad	Tlnp	12.7750	mm

Note:

*Taking a UG-36(c)(3)(a) exemption for nozzle: N2.
 This calculation is valid for nozzles that meet all the requirements of paragraph UG-36. Please check the Code carefully, especially for nozzles that are not isolated or do not meet Code spacing requirements. To force the computation of areas for small nozzles go to Tools->Configuration and check the box to force the UG-37 small nozzle area calculation or force the Appendix 1-10 computation in Nozzle Design Options.*

UG-45 Minimum Nozzle Neck Thickness Requirement: [Int. Press.]

Wall Thickness for Internal/External pressures	ta	= 3.6593	mm
Wall Thickness per UG16(b),	tr16b	= 4.5000	mm
Wall Thickness, shell/head, internal pressure	trb1	= 5.9104	mm
Wall Thickness	tb1 = max(trb1, tr16b)	= 5.9104	mm
Wall Thickness	tb2 = max(trb2, tr16b)	= 4.5000	mm
Wall Thickness per table UG-45	tb3	= 6.4200	mm

Determine Nozzle Thickness candidate [tb]:

$$= \min[tb3, \max(tb1, tb2)]$$

$$= \min[6.42, \max(5.91, 4.5)]$$

$$= 5.9104 \text{ mm}$$

Minimum Wall Thickness of Nozzle Necks [tUG-45]:

$$= \max(ta, tb)$$

$$= \max(3.659, 5.91)$$

$$= 5.9104 \text{ mm}$$

Available Nozzle Neck Thickness = 0.875 * 8.738 = 7.645 mm --> OK

Nozzle Junction Minimum Design Metal Temperature (MDMT) Calculations:

Nozzle Neck to Flange Weld, min(Curve:B, Curve:A)

Govrn. thk, tg = 7.645, tr = 0.659, c = 3 mm, E* = 1
 Thickness Ratio = tr * (E*) / (tg - c) = 0.142, Temp. Reduction = 78 °C

Min Metal Temp. w/o impact per UCS-66, Curve A -8 °C

PV Elite 23 SP2 Licensee: PPV-Engineering B.V.

FileName : 2nd-stage Suction_LI4735 -----

Nozzle Calcs.: N2

Nozl: 13 11:04am Apr 13,2022

Min Metal Temp. at Required thickness (UCS 66.1) -104 °C
 Min Metal Temp. w/o impact per UG-20(f) -29 °C

Nozzle-Shell/Head Weld (UCS-66(a)(b)), Curve: B

Govrn. thk, tg = 7.645, tr = 0.659, c = 3 mm, E* = 1
 Thickness Ratio = $tr * (E*) / (tg - c) = 0.142$, Temp. Reduction = 78 °C

Min Metal Temp. w/o impact per UCS-66, Curve B -29 °C
 Min Metal Temp. at Required thickness (UCS 66.1) -104 °C

Gov. MDMT of the nozzle to shell joint welded assembly : -104 °C

ANSI Flange MDMT including Temperature reduction per UCS-66.1:

Unadjusted MDMT of ASME B16.5/47 flanges per UCS-66(c) -18 °C
 Flange MDMT with Temp reduction per UCS-66(b)(1)(-b) -48 °C

Where the Stress Reduction Ratio per UCS-66(b)(1)(-b) is :

Design Pressure/Ambient Rating = $2.60 / 5.11 = 0.509$

Weld Size Calculations, Description: N2

Intermediate Calc. for nozzle/shell Welds Tmin 5.7376 mm

Results Per UW-16.1:

	Required Thickness	Actual Thickness
Nozzle Weld	$4.0163 = 0.7 * t_{min}$	$4.2420 = 0.7 * W_o$ mm

Skipping the nozzle attachment weld strength calculations.
 Per UW-15(b)(2) the nozzles exempted by UG-36(c)(3)(a)
 (small nozzles) do not require a weld strength check.

Maximum Allowable Pressure for this Nozzle at this Location:

Converged Max. Allow. Pressure in Operating case 3.809 N/mm²

Note: The MAWP of this junction was limited by the parent Shell/Head.

The Drop for this Nozzle is : 3.6270 mm

The Cut Length for this Nozzle is, Drop + Ho + H + T : 79.7370 mm

Note: This nozzle or its diameter limit intersects weld seam # [3] on this element. The distance between the nozzle and seam is, 36.37 mm , while the distance from the center of the nozzle to the edge of the diameter limit is: 48.85 mm

PV Elite is a trademark of Hexagon AB, 2021, All rights reserved.

Input, Nozzle Desc: N3

From: 20

Pressure for Reinforcement Calculations	P	2.6000	N/mm ²
Temperature for Internal Pressure	Temp	80	°C
Parent Material		SA-106 B	
Parent Allowable Stress at Temperature	Sv	117.90	N/mm ²
Parent Allowable Stress At Ambient	Sva	117.90	N/mm ²
Inside Diameter of Cylindrical Shell	D	254.46	mm
Shell Finished (Minimum) Thickness	t	8.1100	mm
Shell Internal Corrosion Allowance	c	3.0000	mm
Shell External Corrosion Allowance	co	0.0000	mm
Distance from Bottom/Left Tangent		339.36	mm
User Entered Minimum Design Metal Temperature		-28.89	°C

Type of Element Connected to the Parent : Nozzle

Material		SA-106 B	
Material UNS Number		K03006	
Material Specification/Type		Smls. pipe	
Allowable Stress at Temperature	Sn	117.90	N/mm ²
Allowable Stress At Ambient	Sna	117.90	N/mm ²
Diameter Basis (for tr calc only)		Outside	
Layout Angle		270.00	deg
Diameter		38.1000	mm
Size and Thickness Basis		Actual	
Actual Thickness	tn	8.3820	mm
Corrosion Allowance	can	3.0000	mm
Joint Efficiency of Shell Seam at Nozzle	E1	1.00	
Joint Efficiency of Nozzle Neck	En	1.00	
Outside Projection	ho	47.6250	mm
Weld leg size between Nozzle and Pad/Shell	Wo	6.0000	mm
Groove weld depth between Nozzle and Vessel	Wgnv	8.3400	mm

The Pressure Design option was Design Pressure + static head.

Nozzle Sketch (may not represent actual weld type/configuration)

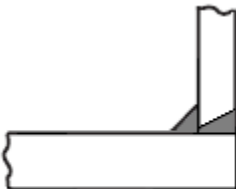

Abutting/Set-on Nozzle No Pad

Reinforcement CALCULATION, Description: N3

ASME Code, Section VIII, Div. 1, 2019, UG-37 to UG-45

Actual Outside Diameter Used in Calculation 38.100 mm.
 Actual Thickness Used in Calculation 8.382 mm

Nozzle input data check completed without errors.

Reqd thk per UG-37(a) of Cylindrical Shell, tr [Int. Press]

$$= P \cdot R / (S_v \cdot E - 0.6 \cdot P) \text{ per UG-27 (c) (1)}$$

$$= 2.6 \cdot 130.2 / (117.9 \cdot 1 - 0.6 \cdot 2.6)$$

$$= 2.9104 \text{ mm}$$

Reqd thk per UG-37(a) of Nozzle Wall, trn [Int. Press]

$$= P \cdot R_o / (S_n \cdot E + 0.4 \cdot P) \text{ per Appendix 1-1 (a) (1)}$$

$$= 2.6 \cdot 19.05 / (117.9 \cdot 1 + 0.4 \cdot 2.6)$$

$$= 0.4164 \text{ mm}$$

UG-40, Limits of Reinforcement : [Internal Pressure]

Parallel to Vessel Wall (Diameter Limit)	D1	54.6720	mm
Parallel to Vessel Wall, opening length	d	27.3360	mm
Normal to Vessel Wall (Thickness Limit), no pad	Tlnp	12.7750	mm

Note:

*Taking a UG-36(c)(3)(a) exemption for nozzle: N3.
 This calculation is valid for nozzles that meet all the requirements of paragraph UG-36. Please check the Code carefully, especially for nozzles that are not isolated or do not meet Code spacing requirements. To force the computation of areas for small nozzles go to Tools->Configuration and check the box to force the UG-37 small nozzle area calculation or force the Appendix 1-10 computation in Nozzle Design Options.*

UG-45 Minimum Nozzle Neck Thickness Requirement: [Int. Press.]

Wall Thickness for Internal/External pressures	ta	= 3.4164	mm
Wall Thickness per UG16(b),	tr16b	= 4.5000	mm
Wall Thickness, shell/head, internal pressure	trb1	= 5.9104	mm
Wall Thickness	tb1 = max(trb1, tr16b)	= 5.9104	mm
Wall Thickness	tb2 = max(trb2, tr16b)	= 4.5000	mm
Wall Thickness per table UG-45	tb3	= 6.1200	mm

Determine Nozzle Thickness candidate [tb]:

$$= \min[tb3, \max(tb1, tb2)]$$

$$= \min[6.12, \max(5.91, 4.5)]$$

$$= 5.9104 \text{ mm}$$

Minimum Wall Thickness of Nozzle Necks [tUG-45]:

$$= \max(ta, tb)$$

$$= \max(3.416, 5.91)$$

$$= 5.9104 \text{ mm}$$

Available Nozzle Neck Thickness = 8.3820 mm --> OK

Nozzle Junction Minimum Design Metal Temperature (MDMT) Calculations:

Nozzle-Shell/Head Weld (UCS-66(a)1(b)), Curve: B

Govrn. thk, tg = 8.11, tr = 2.91, c = 3 mm, E* = 1
 Thickness Ratio = tr * (E*) / (tg - c) = 0.57, Temp. Reduction = 25 °C

Min Metal Temp. w/o impact per UCS-66, Curve B	-29 °C
Min Metal Temp. at Required thickness (UCS 66.1)	-48 °C

Gov. MDMT of the nozzle to shell joint welded assembly : -48 °C

Weld Size Calculations, Description: N3

Intermediate Calc. for nozzle/shell Welds Tmin 5.3820 mm

Results Per UW-16.1:

	Required Thickness	Actual Thickness
Nozzle Weld	$3.7674 = 0.7 * t_{min}$	$4.2420 = 0.7 * W_o$ mm

Skipping the nozzle attachment weld strength calculations.
Per UW-15(b)(2) the nozzles exempted by UG-36(c)(3)(a)
(small nozzles) do not require a weld strength check.

Maximum Allowable Pressure for this Nozzle at this Location:

Converged Max. Allow. Pressure in Operating case 3.809 N/mm²

Note: The MAWP of this junction was limited by the parent Shell/Head.

The Drop for this Nozzle is : 1.4343 mm

The Cut Length for this Nozzle is, Drop + Ho + H + T : 57.1692 mm

PV Elite is a trademark of Hexagon AB, 2021, All rights reserved.

Input, Nozzle Desc: N1

From: 20

Pressure for Reinforcement Calculations	P	2.6000	N/mm ²
Temperature for Internal Pressure	Temp	80	°C
Parent Material		SA-106 B	
Parent Allowable Stress at Temperature	Sv	117.90	N/mm ²
Parent Allowable Stress At Ambient	Sva	117.90	N/mm ²
Inside Diameter of Cylindrical Shell	D	254.46	mm
Shell Finished (Minimum) Thickness	t	8.1100	mm
Shell Internal Corrosion Allowance	c	3.0000	mm
Shell External Corrosion Allowance	co	0.0000	mm
Distance from Bottom/Left Tangent		219.36	mm
User Entered Minimum Design Metal Temperature		-28.89	°C

Type of Element Connected to the Parent : Nozzle

Material		SA-106 B	
Material UNS Number		K03006	
Material Specification/Type		Smls. pipe	
Allowable Stress at Temperature	Sn	117.90	N/mm ²
Allowable Stress At Ambient	Sna	117.90	N/mm ²
Diameter Basis (for tr calc only)		Outside	
Layout Angle		0.00	deg
Diameter		50.0000	mm
Size and Thickness Basis		Nominal	
Nominal Thickness		160	
Flange Material		SA-105	
Flange Type		Weld Neck Flange	
Corrosion Allowance	can	3.0000	mm
Joint Efficiency of Shell Seam at Nozzle	E1	1.00	
Joint Efficiency of Nozzle Neck	En	1.00	
Outside Projection	ho	57.0000	mm
Weld leg size between Nozzle and Pad/Shell	Wo	6.0000	mm
Groove weld depth between Nozzle and Vessel	Wgnv	8.3400	mm

The Pressure Design option was Design Pressure + static head.

Nozzle Sketch (may not represent actual weld type/configuration)

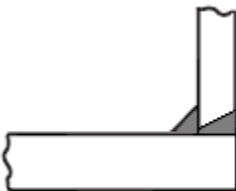

Abutting/Set-on Nozzle No Pad

Reinforcement CALCULATION, Description: N1

ASME Code, Section VIII, Div. 1, 2019, UG-37 to UG-45

Actual Outside Diameter Used in Calculation 60.325 mm.
 Actual Thickness Used in Calculation 8.738 mm

Nozzle input data check completed without errors.

Reqd thk per UG-37(a) of Cylindrical Shell, tr [Int. Press]

$$= P \cdot R / (S_v \cdot E - 0.6 \cdot P) \text{ per UG-27 (c) (1)}$$

$$= 2.6 \cdot 130.2 / (117.9 \cdot 1 - 0.6 \cdot 2.6)$$

$$= 2.9104 \text{ mm}$$

Reqd thk per UG-37(a) of Nozzle Wall, trn [Int. Press]

$$= P \cdot R_o / (S_n \cdot E + 0.4 \cdot P) \text{ per Appendix 1-1 (a) (1)}$$

$$= 2.6 \cdot 30.16 / (117.9 \cdot 1 + 0.4 \cdot 2.6)$$

$$= 0.6593 \text{ mm}$$

UG-40, Limits of Reinforcement : [Internal Pressure]

Parallel to Vessel Wall (Diameter Limit) D1 97.6996 mm
 Parallel to Vessel Wall, opening length d 48.8498 mm
 Normal to Vessel Wall (Thickness Limit), no pad Tlnp 12.7750 mm

Note:

*Taking a UG-36(c)(3)(a) exemption for nozzle: N1.
 This calculation is valid for nozzles that meet all the requirements of
 paragraph UG-36. Please check the Code carefully, especially for nozzles
 that are not isolated or do not meet Code spacing requirements. To force
 the computation of areas for small nozzles go to Tools->Configuration
 and check the box to force the UG-37 small nozzle area calculation or
 force the Appendix 1-10 computation in Nozzle Design Options.*

UG-45 Minimum Nozzle Neck Thickness Requirement: [Int. Press.]

Wall Thickness for Internal/External pressures ta = 3.6593 mm
 Wall Thickness per UG16(b), tr16b = 4.5000 mm
 Wall Thickness, shell/head, internal pressure trb1 = 5.9104 mm
 Wall Thickness tb1 = max(trb1, tr16b) = 5.9104 mm
 Wall Thickness tb2 = max(trb2, tr16b) = 4.5000 mm
 Wall Thickness per table UG-45 tb3 = 6.4200 mm

Determine Nozzle Thickness candidate [tb]:

$$= \min[tb3, \max(tb1, tb2)]$$

$$= \min[6.42, \max(5.91, 4.5)]$$

$$= 5.9104 \text{ mm}$$

Minimum Wall Thickness of Nozzle Necks [tUG-45]:

$$= \max(ta, tb)$$

$$= \max(3.659, 5.91)$$

$$= 5.9104 \text{ mm}$$

Available Nozzle Neck Thickness = 0.875 * 8.738 = 7.645 mm --> OK

Nozzle Junction Minimum Design Metal Temperature (MDMT) Calculations:

Nozzle Neck to Flange Weld, Curve: B

Govern. thk, tg = 7.645, tr = 0.659, c = 3 mm, E* = 1
 Thickness Ratio = tr * (E*) / (tg - c) = 0.142, Temp. Reduction = 78 °C

Min Metal Temp. w/o impact per UCS-66, Curve B -29 °C
 Min Metal Temp. at Required thickness (UCS 66.1) -104 °C

PV Elite 23 SP2 Licensee: PPV-Engineering B.V.
 FileName : 2nd-stage Suction_LI4735 -----
 Nozzle Calcs.: N1 Nozl: 15 11:04am Apr 13,2022

Nozzle-Shell/Head Weld (UCS-66(a)1(b)), Curve: B

Govrn. thk, tg = 7.645, tr = 0.659, c = 3 mm, E* = 1
 Thickness Ratio = $tr * (E*) / (tg - c) = 0.142$, Temp. Reduction = 78 °C

Min Metal Temp. w/o impact per UCS-66, Curve B -29 °C
 Min Metal Temp. at Required thickness (UCS 66.1) -104 °C

Gov. MDMT of the nozzle to shell joint welded assembly : -104 °C

Weld Size Calculations, Description: N1

Intermediate Calc. for nozzle/shell Welds Tmin 5.7376 mm

Results Per UW-16.1:

	Required Thickness	Actual Thickness
Nozzle Weld	4.0163 = 0.7 * tmin.	4.2420 = 0.7 * Wo mm

Skipping the nozzle attachment weld strength calculations.
 Per UW-15(b)(2) the nozzles exempted by UG-36(c)(3)(a)
 (small nozzles) do not require a weld strength check.

Maximum Allowable Pressure for this Nozzle at this Location:

Converged Max. Allow. Pressure in Operating case 3.809 N/mm²

Note: The MAWP of this junction was limited by the parent Shell/Head.

The Drop for this Nozzle is : 3.6270 mm
 The Cut Length for this Nozzle is, Drop + Ho + H + T : 68.7370 mm

Note: This nozzle or its diameter limit intersects weld seam # [1] on this element. The distance between the nozzle and seam is, 0.00 mm , while the distance from the center of the nozzle to the edge of the diameter limit is: 48.85 mm

PV Elite is a trademark of Hexagon AB, 2021, All rights reserved.

Report – N2-Inlet_LI4734

PV-Elite Calculation Summary

Client: Airpack Nederland BV.
Client location: Zierikzee
Ref number client: 17811-OO-0702(KP)

PPV Engineering

Author: H.Hoezen
- Telephone: +31 (0)594 581010
- E-mail: h.hoezen@ppv-engineering.nl

April 19, 2022
Order number: P22-115-01
Document number: 22-11501-C01
Revision: 0

DESIGN CALCULATION

In Accordance with ASME Section VIII Division 1

ASME Code Version : 2019

Analysis Performed by : PPV-Engineering B.V.

Job File : P:\2_ENGINEERING\PROJ-2022\P22-115-AIRZI\01_PV E

Date of Analysis : Apr 13,2022 11:19am

PV Elite 23 SP2, October 2021

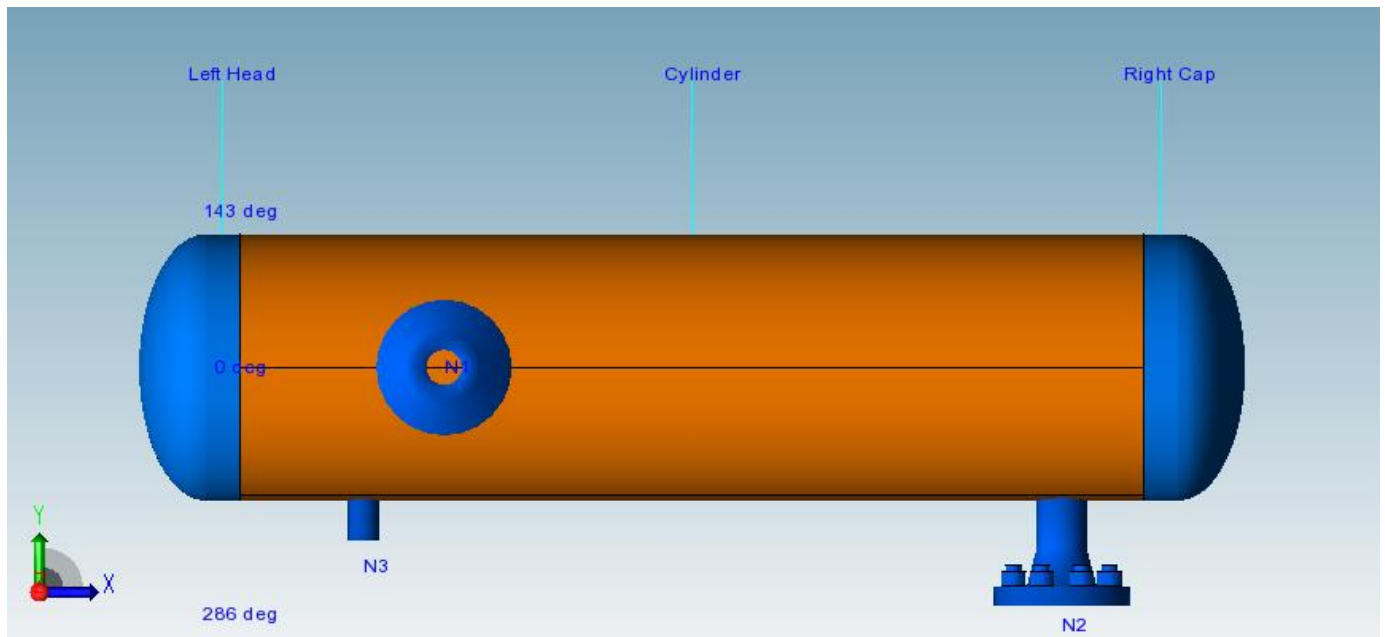

Table of Contents

Cover Sheet:	1
Vessel Design Summary:.....	3
Nozzle Summary:	5
Nozzle Schedule:.....	6
Bill of Material:	7
Input Echo:.....	8
Internal Pressure Calculations:.....	12
Element and Detail Weights:.....	16
Nozzle Flange MAWP:.....	18
Nozzle Calcs.: N2.....	19
Nozzle Calcs.: N3.....	22
Nozzle Calcs.: N1.....	25

Vessel Design Summary:

ASME Code, Section VIII Division 1, 2019

Diameter Spec : 323.800 mm OD	
Vessel Design Length, Tangent to Tangent	1184.63 mm
Specified Datum Line Distance	42.31 mm
Internal Design Temperature	210 °C
Internal Design Pressure	1.450 N/mm ²
External Design Temperature	210 °C
Maximum Allowable Working Pressure	3.204 N/mm ²
Shop Test Pressure	2.550 N/mm ²
Required Minimum Design Metal Temperature	-28.9 °C
Warmest Computed Minimum Design Metal Temperature	-46.0 °C
Wind Design Code	No Wind Loads
Earthquake Design Code	No Seismic

Materials of Construction:

Component Type	Material	Class	Thickness	UNS #	Normal ized	Impact Tested
Shell	SA-106 B	K03006	No	No
Head	SA-234 WPB	K03006	No	No
Nozzle	SA-106 B	K03006	No	No
Nozzle Flg	SA-105	K03504	No	No

Normalized is determined based on the UCS-66 material curve selection and Figure UCS-66.
 Impact Tested is based on material selection and material data properties.

Element Pressures and MAWP (N/mm² & mm):

Element Description or Type	Design Pressure + Stat. head	Ext. Press.	Element M.A.W.P	Total Corrosion Allowance	Str. Flg. Gov.	In Creep Range
Left Head	1.450	0.00	3.942	3.0000	Yes	No
Cylinder	1.450	0.00	3.204	3.0000	N/A	No
Right Cap	1.450	0.00	4.107	3.0000	Yes	No

Element Types and Properties:

Element Type	"To" Elev mm	Element Length mm	Nominal Thickness mm	Finished Thickness mm	Reqd Thk Internal mm	Reqd Thk External mm	Long Eff	Circ Eff
Ellipse	0.0	42.3	9.3	9.3	5.3	4.5	0.85	0.85
Cylinder	1100.0	1100.0	9.5	8.1	5.3	...	0.85	0.85
Ellipse	1142.3	42.3	9.5	9.5	5.3	4.5	0.85	0.85

FileName : N2-Inlet_LI4734 -----

Vessel Design Summary: Step: 15 11:19am Apr 13,2022

Weights:

Fabricated - Bare W/O Removable Internals	114.8	kgm
Shop Test - Fabricated + Water (Full)	210.1	kgm
Shipping - Fab. + Rem. Intls.+ Shipping App.	114.8	kgm
Erected - Fab. + Rem. Intls.+ Insul. (etc)	114.8	kgm
Empty - Fab. + Intls. + Details + Wghts.	114.8	kgm
Operating - Empty + Operating Liquid (No CA)	114.8	kgm
Field Test - Empty Weight + Water (Full)	210.1	kgm

PV Elite is a trademark of Hexagon AB, 2021, All rights reserved.

FileName : N2-Inlet_LI4734

Nozzle Summary:

Step: 13 11:19am Apr 13,2022

Nozzle Calculation Summary:

Description	MAWP N/mm ²	Ext	MAPNC N/mm ²	UG-45	[tr] mm	Weld Path	Areas or Stresses
N2	3.204	OK	4.93	OK	No Calc[*]
N3	3.204	OK	4.93	OK	No Calc[*]
N1	3.204	OK	4.93	OK	No Calc[*]

Nozzle MAWP Summary:

Minimum MAWP Nozzles : 3.204 Nozzle : N1
 Minimum MAWP Shells/Flanges : 3.204 Element : Cylinder
 Minimum MAPnc Shells/Flanges : 5.11 Element : Cylinder

 Computed Vessel M.A.W.P. : 3.204 N/mm²

[*] - This was a small opening and the areas were not computed.

Note: MAWPs (Internal Case) shown above are at the High Point.

Check the Spatial Relationship between the Nozzles:

From Node	Nozzle Description	X Coordinate mm	Layout Angle deg	Dia. Limit mm
20	N2	1042.315	270.000	97.700
20	N3	192.315	270.000	54.672
20	N1	290.315	0.000	97.700

The nozzle spacing is computed by the following:

= Sqrt(ll² + lc²) where

ll - Arc length along the inside vessel surface in the long. direction.

lc - Arc length along the inside vessel surface in the circ. direction

If any interferences/violations are found, they will be noted below.

No interference violations have been detected!

PV Elite is a trademark of Hexagon AB, 2021, All rights reserved.

Nozzle Schedule:

Description	Nominal or Actual Size	Schd or FVC Type	Flg Type	Nozzle O/Dia mm	Wall Thk mm	Reinforcing Diameter	Pad Thk mm	Cut Length mm	Flg Class
N3	38 mm Actual		Non	38.1	8.4	5	...
N2	50 mm	160	WN	60.3	8.7	6	300
N1	50 mm	160	WN	60.3	8.7	6	300

General Notes for the above table:

The Cut Length is the Outside Projection + Inside Projection + Drop + In Plane Shell Thickness. This value does not include weld gaps, nor does it account for shrinkage.

In the case of Oblique Nozzles, the Outside Diameter must be increased. The Re-Pad WIDTH around the nozzle is calculated as follows:
 Width of Pad = (Pad Outside Dia. (per above) - Nozzle Outside Dia.)/2

For hub nozzles, the thickness and diameter shown are those of the smaller and thinner section.

Nozzle Material and Weld Fillet Leg Size Details (mm):

Description	Material	Shl Grve Weld	Noz Shl/Pad Weld	Pad OD Weld	Pad Grve Weld	Inside Weld
N3	SA-106 B	8.340	6.000
N2	SA-106 B	8.340	6.000
N1	SA-106 B	8.340	6.000

Note: The Outside projections below do not include the flange thickness.

Nozzle Miscellaneous Data:

Description	Elev/Distance From Datum mm	Layout Angle deg	Proj Outside mm	Proj Inside mm	Installed in Component
N3	150.000	270.0	47.62	0.00	Cylinder
N2	1000.000	270.0	57.00	0.00	Cylinder
N1	248.000	0.0	57.00	0.00	Cylinder

Bill of Materials:

QTY	DESCRIPTION	MATERIAL
1	ELLIPTICAL HEAD: 2.0 X 1, 9.3mm THK X 305.3mm ID X 42.3mm	SA-234 WPB
1	ELLIPTICAL HEAD: 2.0 X 1, 9.5mm THK X 304.8mm ID X 42.3mm	SA-234 WPB
2	CYLINDRICAL SEGMENT 9.5mm THK X 383.8mm X 1100.0mm	SA-106 B
1	CYLINDRICAL SEGMENT 9.5mm THK X 198.6mm X 1100.0mm	SA-106 B
1	NAMEPLATE	...

PV Elite is a trademark of Hexagon AB, 2021, All rights reserved.

PV Elite Vessel Analysis Program: Input Data

Design Internal Pressure (for Hydrotest)	1.45	N/mm ²
Design Internal Temperature	210.0	°C
Projection of Nozzle from Vessel Top	0	mm
Projection of Nozzle from Vessel Bottom	0	mm
Minimum Design Metal Temperature	-28.9	°C
Type of Construction	Welded	
Special Service	None	
Degree of Radiography	RT-3	
Use Higher Longitudinal Stresses (Flag)	Y	
Select t for Internal Pressure (Flag)	N	
Select t for External Pressure (Flag)	N	
Select t for Axial Stress (Flag)	N	
Select Location for Stiff. Rings (Flag)	N	
Consider Vortex Shedding	N	
Perform a Corroded Hydrotest	N	

Shop Pressure Test:

Type of Pressure Test	User Entered Pressure
Pressure Test Position	Horizontal
Load Case 1	NP+EW+WI+FW+BW
Load Case 2	NP+EW+EE+FS+BS
Load Case 3	NP+OW+WI+FW+BW
Load Case 4	NP+OW+EQ+FS+BS
Load Case 5	NP+HW+HI
Load Case 6	NP+HW+HE
Load Case 7	IP+OW+WI+FW+BW
Load Case 8	IP+OW+EQ+FS+BS
Load Case 9	EP+OW+WI+FW+BW
Load Case 10	EP+OW+EQ+FS+BS
Load Case 11	HP+HW+HI
Load Case 12	HP+HW+HE
Load Case 13	IP+WE+EW
Load Case 14	IP+WF+CW
Load Case 15	IP+VO+OW
Load Case 16	IP+VE+EW
Load Case 17	NP+VO+OW
Load Case 18	FS+BS+IP+OW
Load Case 19	FS+BS+EP+OW
Wind Design Code	No Wind Loads
Seismic Design Code	No Seismic
Design Pressure + Static Head	Y
Consider MAP New and Cold in Noz. Design	N
Consider External Loads for Nozzle Des.	Y
Use ASME VIII-1 Appendix 1-9	N

Material Database Year Current w/Addenda or Code Year

Configuration Directives:

Do not use Nozzle MDMT Interpretation VIII-1 01-37	No
Use Table G instead of exact equation for "A"	Yes
Shell Head Joints are Tapered	Yes
Compute "K" in corroded condition	Yes
Use Code Case 2286	No
Use the MAWP to compute the MDMT	Yes
For thickness ratios <= 0.35, MDMT will be -155F (-104C)	Yes
For PWHT & P1 Materials the MDMT can be < -55F (-48C)	No

FileName : N2-Inlet_LI4734 -----

Input Echo: Step: 1 11:19am Apr 13,2022

Using Metric Material Databases, ASME II D No
 Calculate B31.3 type stress for Nozzles with Loads Yes
 Reduce the MDMT due to lower membrane stress Yes
 Consider Longitudinal Stress in MDMT calcs. (Div. 1) Yes

Complete Listing of Vessel Elements and Details:

Element From Node 10
 Element To Node 20
 Element Type Elliptical
 Description Left Head
 Distance "FROM" to "TO" 42.315 mm
 Element Outside Diameter 323.8 mm
 Element Thickness 9.27 mm
 Internal Corrosion Allowance 3 mm
 Nominal Thickness 9.27 mm
 External Corrosion Allowance 0 mm
 Design Internal Pressure 1.45 N/mm²
 Design Temperature Internal Pressure 210 °C
 Design External Pressure 0 N/mm²
 Design Temperature External Pressure 210 °C
 Effective Diameter Multiplier 1.2
 Material Name SA-234 WPB
 Allowable Stress, Ambient 117.9 N/mm²
 Allowable Stress, Operating 117.9 N/mm²
 Allowable Stress, Hydrotest 153.27 N/mm²
 Material Density 7750.4 kg/m³
 P Number Thickness 30.988 mm
 Yield Stress, Operating 205.19 N/mm²
 UCS-66 Chart Curve Designation B
 External Pressure Chart Name CS-2
 UNS Number K03006
 Product Form Smls. & wld. fittings
 Efficiency, Longitudinal Seam 0.85
 Efficiency, Circumferential Seam 0.85
 Elliptical Head Factor 2.0
 Weld is pre-Heated No

 Element From Node 20
 Element To Node 30
 Element Type Cylinder
 Description Cylinder
 Distance "FROM" to "TO" 1100 mm
 Element Outside Diameter 323.8 mm
 Element Thickness 8.11 mm
 Internal Corrosion Allowance 3 mm
 Nominal Thickness 9.53 mm
 External Corrosion Allowance 0 mm
 Design Internal Pressure 1.45 N/mm²
 Design Temperature Internal Pressure 210 °C
 Design External Pressure 0 N/mm²
 Design Temperature External Pressure 210 °C
 Effective Diameter Multiplier 1.2
 Material Name SA-106 B
 Allowable Stress, Ambient 117.9 N/mm²
 Allowable Stress, Operating 117.9 N/mm²
 Allowable Stress, Hydrotest 153.27 N/mm²
 Material Density 7750.4 kg/m³
 P Number Thickness 30.988 mm
 Yield Stress, Operating 205.19 N/mm²
 UCS-66 Chart Curve Designation B
 External Pressure Chart Name CS-2

FileName : N2-Inlet_LI4734

Input Echo: Step: 1 11:19am Apr 13,2022

UNS Number	K03006
Product Form	Smls. pipe
Efficiency, Longitudinal Seam	0.85
Efficiency, Circumferential Seam	0.85
Weld is pre-Heated	No

Element From Node	20
Detail Type	Nozzle
Detail ID	N2
Dist. from "FROM" Node / Offset dist	1000 mm
Nozzle Diameter	50 mm
Nozzle Schedule	160
Nozzle Class	300
Layout Angle	270.0
Blind Flange (Y/N)	N
Weight of Nozzle (Used if > 0)	0 N
Grade of Attached Flange	GR 1.1
Nozzle Matl	SA-106 B

Element From Node	20
Detail Type	Nozzle
Detail ID	N3
Dist. from "FROM" Node / Offset dist	150 mm
Nozzle Diameter	38.1 mm
Nozzle Schedule	None
Nozzle Class	None
Layout Angle	270.0
Blind Flange (Y/N)	N
Weight of Nozzle (Used if > 0)	0 N
Grade of Attached Flange	None
Nozzle Matl	SA-106 B

Element From Node	20
Detail Type	Nozzle
Detail ID	N1
Dist. from "FROM" Node / Offset dist	248 mm
Nozzle Diameter	50 mm
Nozzle Schedule	160
Nozzle Class	300
Layout Angle	0.0
Blind Flange (Y/N)	N
Weight of Nozzle (Used if > 0)	0 N
Grade of Attached Flange	GR 1.1
Nozzle Matl	SA-106 B

Element From Node	30
Element To Node	40
Element Type	Elliptical
Description	Right Cap
Distance "FROM" to "TO"	42.315 mm
Element Outside Diameter	323.9 mm
Element Thickness	9.53 mm
Internal Corrosion Allowance	3 mm
Nominal Thickness	9.53 mm
External Corrosion Allowance	0 mm
Design Internal Pressure	1.45 N/mm ²
Design Temperature Internal Pressure	210 °C
Design External Pressure	0 N/mm ²
Design Temperature External Pressure	210 °C
Effective Diameter Multiplier	1.2
Material Name	SA-234 WPB
Allowable Stress, Ambient	117.9 N/mm ²
Allowable Stress, Operating	117.9 N/mm ²

FileName : N2-Inlet_LI4734 -----

Input Echo: Step: 1 11:19am Apr 13,2022

Allowable Stress, Hydrotest	153.27	N/mm ²
Material Density	7750.4	kg/m ³
P Number Thickness	30.988	mm
Yield Stress, Operating	205.19	N/mm ²
UCS-66 Chart Curve Designation		B
External Pressure Chart Name		CS-2
UNS Number		K03006
Product Form	Smls. & wld. fittings	
Efficiency, Longitudinal Seam		0.85
Efficiency, Circumferential Seam		0.85
Elliptical Head Factor		2.0
Weld is pre-Heated		No

PV Elite is a trademark of Hexagon AB, 2021, All rights reserved.

PV Elite 23 SP2 Licensee: PPV-Engineering B.V.

FileName : N2-Inlet_LI4734 -----

Internal Pressure Calculations: Step: 3 11:19am Apr 13,2022

Internal Pressure Results Summary:

Element Thickness, Pressure, Diameter and Allowable Stress :

From	To	Int. Press + Liq. Hd N/mm ²	Nominal Thickness mm	Total Corr Allowance mm	Element Diameter mm	Allowable Stress (SE) N/mm ²
Left Head		1.45	9.27	3	323.8	100.22
Cylinder		1.45	9.53	3	323.8	100.22
Right Cap		1.45	9.53	3	323.9	100.22

Element Required Thickness and MAWP :

From	To	Design Pressure N/mm ²	M.A.W.P. Corroded N/mm ²	M.A.P. New & Cold N/mm ²	Minimum Thickness mm	Required Thickness mm
Left Head		1.45	3.942	6.05	9.27	5.25544
Cylinder		1.45	3.204	5.123	8.11	5.32903
Right Cap		1.45	4.107	6.227	9.53	5.25606
Minimum			3.204	5.11		

Note : The M.A.P.(NC) is Governed by a Flange !

MAWP: 3.204 N/mm², limited by: Cylinder.

Elements Suitable for Design Internal Pressure.

Internal Pressure Calculation Results:

ASME Code, Section VIII Division 1, 2019

Elliptical Head From 10 To 20 SA-234 WPB , UCS-66 Crv. B at 210 °C

Left Head

Material UNS Number: K03006

Required Thickness due to Internal Pressure [tr]:

$$= (P \cdot Do \cdot K_{cor}) / (2 \cdot S \cdot E + 2 \cdot P \cdot (K_{cor} - 0.1)) \text{ per Appendix 1-4 (c)}$$

$$= (1.45 \cdot 323.8 \cdot 0.975) / (2 \cdot 117.9 \cdot 0.85 + 2 \cdot 1.45 \cdot (0.975 - 0.1))$$

$$= 2.2554 + 3.0000 = 5.2554 \text{ mm}$$

Max. Allowable Working Pressure at given Thickness, corroded [MAWP]:

$$= (2 \cdot S \cdot E \cdot t) / (K_{cor} \cdot Do - 2 \cdot t \cdot (K_{cor} - 0.1)) \text{ per Appendix 1-4 (c)}$$

$$= (2 \cdot 117.9 \cdot 0.85 \cdot 6.27) / (0.975 \cdot 323.8 - 2 \cdot 6.27 \cdot (0.975 - 0.1))$$

$$= 4.124 \text{ N/mm}^2$$

Maximum Allowable Pressure, New and Cold [MAPNC]:

$$= (2 \cdot S \cdot E \cdot t) / (K \cdot Do - 2 \cdot t \cdot (K - 0.1)) \text{ per Appendix 1-4 (c)}$$

$$= (2 \cdot 117.9 \cdot 0.85 \cdot 9.27) / (1 \cdot 323.8 - 2 \cdot 9.27 \cdot (1 - 0.1))$$

$$= 6.05 \text{ N/mm}^2$$

Actual stress at given pressure and thickness, corroded [Sact]:

$$= (P \cdot (K_{cor} \cdot Do - 2 \cdot t \cdot (K_{cor} - 0.1))) / (2 \cdot E \cdot t)$$

$$= (1.45 \cdot (0.975 \cdot 323.8 - 2 \cdot 6.27 \cdot (0.975 - 0.1))) / (2 \cdot 0.85 \cdot 6.27)$$

$$= 41.455 \text{ N/mm}^2$$

Straight Flange Required Thickness:

$$= (P \cdot Ro) / (S \cdot E + 0.4 \cdot P) + ca \text{ per Appendix 1-1 (a) (1)}$$

$$= (1.45 \cdot 161.9) / (117.9 \cdot 0.85 + 0.4 \cdot 1.45) + 3$$

PV Elite 23 SP2 Licensee: PPV-Engineering B.V.

FileName : N2-Inlet_LI4734 -----

Internal Pressure Calculations: Step: 3 11:19am Apr 13,2022

$$= 5.329 \text{ mm}$$

Straight Flange Maximum Allowable Working Pressure:

$$= (S \cdot E \cdot t) / (R_o - 0.4 \cdot t) \text{ per Appendix 1-1 (a) (1)}$$

$$= (117.9 \cdot 0.85 \cdot 6.27) / (161.9 - 0.4 \cdot 6.27)$$

$$= 3.942 \text{ N/mm}^2$$

Factor K, corroded condition [Kcor]:

$$= (2 + (\text{Inside Diameter} / (2 \cdot \text{Inside Head Depth}))^2) / 6$$

$$= (2 + (311.3 / (2 \cdot 79.31))^2) / 6$$

$$= 0.975023$$

MDMT Calculations in the Knuckle Portion:

Govrn. thk, tg = 9.27, tr = 4.909, c = 3 mm, E* = 0.85

Thickness Ratio = tr * (E*) / (tg - c) = 0.665, Temp. Reduction = 19 °C

Min Metal Temp. w/o impact per UCS-66, Curve B -29 °C
 Min Metal Temp. at Required thickness (UCS 66.1) -47 °C

MDMT Calculations in the Head Straight Flange:

Govrn. thk, tg = 9.27, tr = 5.11, c = 3 mm, E* = 0.85

Thickness Ratio = tr * (E*) / (tg - c) = 0.693, Temp. Reduction = 17 °C

Min Metal Temp. w/o impact per UCS-66, Curve B -29 °C
 Min Metal Temp. at Required thickness (UCS 66.1) -46 °C

Cylindrical Shell From 20 To 30 SA-106 B, UCS-66 Crv. B at 210 °C

Cylinder

Longitudinal Joint: Seamless

Material UNS Number: K03006

Required Thickness due to Internal Pressure [tr]:

$$= (P \cdot R_o) / (S \cdot E + 0.4 \cdot P) \text{ per Appendix 1-1 (a) (1)}$$

$$= (1.45 \cdot 161.9) / (117.9 \cdot 0.85 + 0.4 \cdot 1.45)$$

$$= 2.3290 + 3.0000 = 5.3290 \text{ mm}$$

Max. Allowable Working Pressure at given Thickness, corroded [MAWP]:

$$= (S \cdot E \cdot t) / (R_o - 0.4 \cdot t) \text{ per Appendix 1-1 (a) (1)}$$

$$= (117.9 \cdot 0.85 \cdot 5.11) / (161.9 - 0.4 \cdot 5.11)$$

$$= 3.204 \text{ N/mm}^2$$

Maximum Allowable Pressure, New and Cold [MAPNC]:

$$= (S \cdot E \cdot t) / (R_o - 0.4 \cdot t) \text{ per Appendix 1-1 (a) (1)}$$

$$= (117.9 \cdot 0.85 \cdot 8.11) / (161.9 - 0.4 \cdot 8.11)$$

$$= 5.123 \text{ N/mm}^2$$

Actual stress at given pressure and thickness, corroded [Sact]:

$$= (P \cdot (R_o - 0.4 \cdot t)) / (E \cdot t)$$

$$= (1.45 \cdot ((161.9 - 0.4 \cdot 5.11))) / (0.85 \cdot 5.11)$$

$$= 53.365 \text{ N/mm}^2$$

Minimum Design Metal Temperature Results:

Govrn. thk, tg = 8.11, tr = 2.49, c = 3 mm, E* = 0.85

Thickness Ratio = tr * (E*) / (tg - c) = 0.414, Temp. Reduction = 47 °C

Min Metal Temp. w/o impact per UCS-66, Curve B -29 °C
 Min Metal Temp. at Required thickness (UCS 66.1) -48 °C

Elliptical Head From 30 To 40 SA-234 WPB, UCS-66 Crv. B at 210 °C

Right Cap

Material UNS Number: K03006

Required Thickness due to Internal Pressure [tr]:

$$= (P \cdot Do \cdot K_{cor}) / (2 \cdot S \cdot E + 2 \cdot P \cdot (K_{cor} - 0.1)) \text{ per Appendix 1-4 (c)}$$

$$= (1.45 \cdot 323.9 \cdot 0.975) / (2 \cdot 117.9 \cdot 0.85 + 2 \cdot 1.45 \cdot (0.975 - 0.1))$$

$$= 2.2561 + 3.0000 = 5.2561 \text{ mm}$$

Max. Allowable Working Pressure at given Thickness, corroded [MAWP]:

$$= (2 \cdot S \cdot E \cdot t) / (K_{cor} \cdot Do - 2 \cdot t \cdot (K_{cor} - 0.1)) \text{ per Appendix 1-4 (c)}$$

$$= (2 \cdot 117.9 \cdot 0.85 \cdot 6.53) / (0.975 \cdot 323.9 - 2 \cdot 6.53 \cdot (0.975 - 0.1))$$

$$= 4.3 \text{ N/mm}^2$$

Maximum Allowable Pressure, New and Cold [MAPNC]:

$$= (2 \cdot S \cdot E \cdot t) / (K \cdot Do - 2 \cdot t \cdot (K - 0.1)) \text{ per Appendix 1-4 (c)}$$

$$= (2 \cdot 117.9 \cdot 0.85 \cdot 9.53) / (1 \cdot 323.9 - 2 \cdot 9.53 \cdot (1 - 0.1))$$

$$= 6.227 \text{ N/mm}^2$$

Actual stress at given pressure and thickness, corroded [Sact]:

$$= (P \cdot (K_{cor} \cdot Do - 2 \cdot t \cdot (K_{cor} - 0.1))) / (2 \cdot E \cdot t)$$

$$= (1.45 \cdot (0.975 \cdot 323.9 - 2 \cdot 6.53 \cdot (0.975 - 0.1))) / (2 \cdot 0.85 \cdot 6.53)$$

$$= 39.757 \text{ N/mm}^2$$

Straight Flange Required Thickness:

$$= (P \cdot Ro) / (S \cdot E + 0.4 \cdot P) + ca \text{ per Appendix 1-1 (a) (1)}$$

$$= (1.45 \cdot 161.9) / (117.9 \cdot 0.85 + 0.4 \cdot 1.45) + 3$$

$$= 5.330 \text{ mm}$$

Straight Flange Maximum Allowable Working Pressure:

$$= (S \cdot E \cdot t) / (Ro - 0.4 \cdot t) \text{ per Appendix 1-1 (a) (1)}$$

$$= (117.9 \cdot 0.85 \cdot 6.53) / (161.9 - 0.4 \cdot 6.53)$$

$$= 4.107 \text{ N/mm}^2$$

Factor K, corroded condition [Kcor]:

$$= (2 + (\text{Inside Diameter} / (2 \cdot \text{Inside Head Depth}))^2) / 6$$

$$= (2 + (310.8 / (2 \cdot 79.21))^2) / 6$$

$$= 0.974990$$

MDMT Calculations in the Knuckle Portion:

Govrn. thk, tg = 9.53, tr = 4.91, c = 3 mm, E* = 0.85
 Thickness Ratio = tr * (E*) / (tg - c) = 0.639, Temp. Reduction = 20 °C

Min Metal Temp. w/o impact per UCS-66, Curve B -29 °C
 Min Metal Temp. at Required thickness (UCS 66.1) -48 °C

MDMT Calculations in the Head Straight Flange:

Govrn. thk, tg = 9.53, tr = 5.112, c = 3 mm, E* = 0.85
 Thickness Ratio = tr * (E*) / (tg - c) = 0.665, Temp. Reduction = 19 °C

Min Metal Temp. w/o impact per UCS-66, Curve B -29 °C
 Min Metal Temp. at Required thickness (UCS 66.1) -47 °C

Note: Heads and Shells Exempted to -20F (-29C) by paragraph UG-20F

Hydrostatic Test Pressure Results:

Pressure per UG99b	= 1.30 * M.A.W.P. * Sa/S	4.165	N/mm ²
Pressure per UG99b[35]	= 1.30 * Design Pres * Sa/S	1.885	N/mm ²
Pressure per UG99c	= 1.30 * M.A.P. - Head(Hyd)	6.643	N/mm ²
Pressure per UG100	= 1.10 * M.A.W.P. * Sa/S	3.524	N/mm ²

PV Elite 23 SP2 Licensee: PPV-Engineering B.V.

FileName : N2-Inlet_LI4734 -----

Internal Pressure Calculations: Step: 3 11:19am Apr 13,2022

Pressure per PED = max(1.43*DP, 1.25*DP*ratio) 2.073 N/mm²
 Pressure per App 27-4 = M.A.W.P. 3.204 N/mm²
 User Defined Hydrostatic Test Pressure at High Point 2.550 N/mm²

Horizontal Test performed per: User Hydro Pressure

Please note that Nozzle, Shell, Head, Flange, etc MAWPs are all considered when determining the hydrotest pressure for those test types that are based on the MAWP of the vessel.

Stresses on Elements due to Test Pressure (N/mm²):

From To	Stress	Allowable	Ratio	Pressure
Left Head	49.8	153.3	0.325	2.55
Cylinder	58.8	153.3	0.383	2.55
Right Cap	48.3	153.3	0.315	2.55

Stress ratios for Nozzle and Pad Materials (N/mm²):

Description	Pad/Nozzle	Ambient	Operating	Ratio
N2	Nozzle	117.90	117.90	1.000
N3	Nozzle	117.90	117.90	1.000
N1	Nozzle	117.90	117.90	1.000
Minimum				1.000

Stress ratios for Pressurized Vessel Elements (N/mm²):

Description	Ambient	Operating	Ratio
Left Head	117.90	117.90	1.000
Cylinder	117.90	117.90	1.000
Right Cap	117.90	117.90	1.000
Minimum			1.000

Hoop Stress in Nozzle Wall during Pressure Test (N/mm²):

Description	Ambient	Operating	Ratio
N2	7.79	153.27	0.051
N3	4.78	153.27	0.031
N1	7.79	153.27	0.051

Elements Suitable for Test Pressure.

PV Elite is a trademark of Hexagon AB, 2021, All rights reserved.

Element and Detail Weights:

From	To	Element Metal Wgt. kgm	Element ID Volume m³	Corroded Metal Wgt. kgm	Corroded ID Volume m³	Extra due Misc %
10	20	11.5111	0.0068216	7.78581	0.0071685	...
20	30	80.9422	0.081748	55.9867	0.084968	...
30	40	11.8235	0.0067977	8.10149	0.0071438	...
Total		104	0.10	71	0.10	0

Weight of Details:

From	Type	Weight of Detail kgm	X Offset, Dtl. Cent. mm	Y Offset, Dtl. Cent. mm	Z Offset, Dtl. Cent. mm	Description
20	Noz1	5.12457	1000	-183.952	...	N2
20	Noz1	0.28886	150	-172.84	...	N3
20	Noz1	5.12457	248	...	183.952	N1

Total Weight of Each Detail Type:

Nozzles	10.5
Sum of the Detail Weights	10.5 kgm

Weight Summation Results: (kgm)

	Fabricated	Shop Test	Shipping	Erected	Empty	Operating
Main Elements	104.3	104.3	104.3	104.3	104.3	104.3
Nozzles	10.5	10.5	10.5	10.5	10.5	10.5
Test Liquid	...	95.3
Totals	114.8	210.1	114.8	114.8	114.8	114.8

Weight Summary:

Fabricated Wt.	- Bare Weight without Removable Internals	114.8 kgm
Shop Test Wt.	- Fabricated Weight + Water (Full)	210.1 kgm
Shipping Wt.	- Fab. Weight + removable Intls.+ Shipping App.	114.8 kgm
Erected Wt.	- Fab. Wt + or - loose items (trays,platforms etc.)	114.8 kgm
Ope. Wt. no Liq	- Fab. Weight + Internals. + Details + Weights	114.8 kgm
Operating Wt.	- Empty Weight + Operating Liq. Uncorroded	114.8 kgm
Oper. Wt. + CA	- Corr Wt. + Operating Liquid	82.4 kgm
Field Test Wt.	- Empty Weight + Water (Full)	210.1 kgm

Note:

The Corroded Weight and thickness are used in the Horizontal Vessel Analysis (Ope Case) and Earthquake Load Calculations.

Outside Surface Areas of Elements:

From	To	Surface Area cm²
10	20	1566.97
20	30	11287.9
30	40	1567.8

PV Elite 23 SP2 Licensee: PPV-Engineering B.V.

FileName : N2-Inlet_LI4734 -----

Element and Detail Weights: Step: 5 11:19am Apr 13,2022

Total 14422.642 cm²

PV Elite is a trademark of Hexagon AB, 2021, All rights reserved.

FileName : N2-Inlet_LI4734 -----

Nozzle Flange MAWP: Step: 6 11:19am Apr 13,2022

Nozzle Flange MAWP Results: (N/mm² & °C)

Nozzle Description	Flange Rating		Design Temp	Class	Grade/ Group	Equiv. Press	Max Pressure		
	Ope.	Ambient					UG-44(b)	50%	DNV
N2	4.34	5.11	210	300	GR 1.1
N1	4.34	5.11	210	300	GR 1.1
Min Rating	4.342	5.110 N/mm ² [for Core Elements]					0.000	0.000	0.000

Pressure Ratings are per ASME B16.5 2013 Metric Edition

PV Elite is a trademark of Hexagon AB, 2021, All rights reserved.

Input, Nozzle Desc: N2

From: 20

Pressure for Reinforcement Calculations	P	1.4500	N/mm ²
Temperature for Internal Pressure	Temp	210	°C
Parent Material		SA-106 B	
Parent Allowable Stress at Temperature	Sv	117.90	N/mm ²
Parent Allowable Stress At Ambient	Sva	117.90	N/mm ²
Inside Diameter of Cylindrical Shell	D	304.74	mm
Shell Finished (Minimum) Thickness	t	8.1100	mm
Shell Internal Corrosion Allowance	c	3.0000	mm
Shell External Corrosion Allowance	co	0.0000	mm
Distance from Bottom/Left Tangent		1042.31	mm
User Entered Minimum Design Metal Temperature		-28.89	°C

Type of Element Connected to the Parent : Nozzle

Material		SA-106 B	
Material UNS Number		K03006	
Material Specification/Type		Smls. pipe	
Allowable Stress at Temperature	Sn	117.90	N/mm ²
Allowable Stress At Ambient	Sna	117.90	N/mm ²
Diameter Basis (for tr calc only)		Outside	
Layout Angle		270.00	deg
Diameter		50.0000	mm
Size and Thickness Basis		Nominal	
Nominal Thickness		160	
Flange Material		SA-105	
Flange Type		Weld Neck Flange	
Corrosion Allowance	can	3.0000	mm
Joint Efficiency of Shell Seam at Nozzle	E1	1.00	
Joint Efficiency of Nozzle Neck	En	1.00	
Outside Projection	ho	57.0000	mm
Weld leg size between Nozzle and Pad/Shell	Wo	6.0000	mm
Groove weld depth between Nozzle and Vessel	Wgnv	8.3400	mm
Flange Class		300	
Flange Grade		GR 1.1	

The Pressure Design option was Design Pressure + static head.

Nozzle Sketch (may not represent actual weld type/configuration)



Abutting/Set-on Nozzle No Pad

Reinforcement CALCULATION, Description: N2

ASME Code, Section VIII, Div. 1, 2019, UG-37 to UG-45

Actual Outside Diameter Used in Calculation 60.325 mm.
 Actual Thickness Used in Calculation 8.738 mm

Nozzle input data check completed without errors.

Reqd thk per UG-37(a) of Cylindrical Shell, tr [Int. Press]

$$= P \cdot R / (S_v \cdot E - 0.6 \cdot P) \text{ per UG-27 (c) (1)}$$

$$= 1.45 \cdot 155.4 / (117.9 \cdot 1 - 0.6 \cdot 1.45)$$

$$= 1.9250 \text{ mm}$$

Reqd thk per UG-37(a) of Nozzle Wall, trn [Int. Press]

$$= P \cdot R_o / (S_n \cdot E + 0.4 \cdot P) \text{ per Appendix 1-1 (a) (1)}$$

$$= 1.45 \cdot 30.16 / (117.9 \cdot 1 + 0.4 \cdot 1.45)$$

$$= 0.3691 \text{ mm}$$

UG-40, Limits of Reinforcement : [Internal Pressure]

Parallel to Vessel Wall (Diameter Limit) D1 97.6996 mm
 Parallel to Vessel Wall, opening length d 48.8498 mm
 Normal to Vessel Wall (Thickness Limit), no pad Tlnp 12.7750 mm

Note:

*Taking a UG-36(c)(3)(a) exemption for nozzle: N2.
 This calculation is valid for nozzles that meet all the requirements of paragraph UG-36. Please check the Code carefully, especially for nozzles that are not isolated or do not meet Code spacing requirements. To force the computation of areas for small nozzles go to Tools->Configuration and check the box to force the UG-37 small nozzle area calculation or force the Appendix 1-10 computation in Nozzle Design Options.*

UG-45 Minimum Nozzle Neck Thickness Requirement: [Int. Press.]

Wall Thickness for Internal/External pressures ta = 3.3691 mm
 Wall Thickness per UG16(b), tr16b = 4.5000 mm
 Wall Thickness, shell/head, internal pressure trb1 = 4.9250 mm
 Wall Thickness tb1 = max(trb1, tr16b) = 4.9250 mm
 Wall Thickness tb2 = max(trb2, tr16b) = 4.5000 mm
 Wall Thickness per table UG-45 tb3 = 6.4200 mm

Determine Nozzle Thickness candidate [tb]:

$$= \min[tb3, \max(tb1, tb2)]$$

$$= \min[6.42, \max(4.925, 4.5)]$$

$$= 4.9250 \text{ mm}$$

Minimum Wall Thickness of Nozzle Necks [tUG-45]:

$$= \max(ta, tb)$$

$$= \max(3.369, 4.925)$$

$$= 4.9250 \text{ mm}$$

Available Nozzle Neck Thickness = 0.875 * 8.738 = 7.645 mm --> OK

Nozzle Junction Minimum Design Metal Temperature (MDMT) Calculations:

Nozzle Neck to Flange Weld, min(Curve:B, Curve:A)

Govrn. thk, tg = 7.645, tr = 0.369, c = 3 mm, E* = 1
 Thickness Ratio = tr * (E*) / (tg - c) = 0.0795, Temp. Reduction = 78 °C

Min Metal Temp. w/o impact per UCS-66, Curve A -8 °C

PV Elite 23 SP2 Licensee: PPV-Engineering B.V.

FileName : N2-Inlet_LI4734 -----

Nozzle Calcs.: N2 Nozl: 13 11:19am Apr 13,2022

Min Metal Temp. at Required thickness (UCS 66.1) -104 °C
 Min Metal Temp. w/o impact per UG-20(f) -29 °C

Nozzle-Shell/Head Weld (UCS-66(a)(b)), Curve: B

Govrn. thk, tg = 7.645, tr = 0.369, c = 3 mm, E* = 1
 Thickness Ratio = $tr * (E*) / (tg - c) = 0.0795$, Temp. Reduction = 78 °C

Min Metal Temp. w/o impact per UCS-66, Curve B -29 °C
 Min Metal Temp. at Required thickness (UCS 66.1) -104 °C

Gov. MDMT of the nozzle to shell joint welded assembly : -104 °C

ANSI Flange MDMT including Temperature reduction per UCS-66.1:

Unadjusted MDMT of ASME B16.5/47 flanges per UCS-66(c) -18 °C
 Flange MDMT with Temp reduction per UCS-66(b)(1)(-b) -104 °C

Where the Stress Reduction Ratio per UCS-66(b)(1)(-b) is :

Design Pressure/Ambient Rating = $1.45/5.11 = 0.284$

Weld Size Calculations, Description: N2

Intermediate Calc. for nozzle/shell Welds Tmin 5.7376 mm

Results Per UW-16.1:

	Required Thickness	Actual Thickness
Nozzle Weld	$4.0163 = 0.7 * t_{min}$	$4.2420 = 0.7 * W_o$ mm

Skipping the nozzle attachment weld strength calculations.
 Per UW-15(b)(2) the nozzles exempted by UG-36(c)(3)(a)
 (small nozzles) do not require a weld strength check.

Maximum Allowable Pressure for this Nozzle at this Location:

Converged Max. Allow. Pressure in Operating case 3.204 N/mm²

Note: The MAWP of this junction was limited by the parent Shell/Head.

The Drop for this Nozzle is : 3.0153 mm

The Cut Length for this Nozzle is, Drop + Ho + H + T : 68.1253 mm

Note: This nozzle or its diameter limit intersects weld seam # [3] on this element. The distance between the nozzle and seam is, 43.39 mm , while the distance from the center of the nozzle to the edge of the diameter limit is: 48.85 mm

PV Elite is a trademark of Hexagon AB, 2021, All rights reserved.

Input, Nozzle Desc: N3

From: 20

Pressure for Reinforcement Calculations	P	1.4500	N/mm ²
Temperature for Internal Pressure	Temp	210	°C
Parent Material		SA-106 B	
Parent Allowable Stress at Temperature	Sv	117.90	N/mm ²
Parent Allowable Stress At Ambient	Sva	117.90	N/mm ²
Inside Diameter of Cylindrical Shell	D	304.74	mm
Shell Finished (Minimum) Thickness	t	8.1100	mm
Shell Internal Corrosion Allowance	c	3.0000	mm
Shell External Corrosion Allowance	co	0.0000	mm
Distance from Bottom/Left Tangent		192.32	mm
User Entered Minimum Design Metal Temperature		-28.89	°C

Type of Element Connected to the Parent : Nozzle

Material		SA-106 B	
Material UNS Number		K03006	
Material Specification/Type		Smls. pipe	
Allowable Stress at Temperature	Sn	117.90	N/mm ²
Allowable Stress At Ambient	Sna	117.90	N/mm ²
Diameter Basis (for tr calc only)		Outside	
Layout Angle		270.00	deg
Diameter		38.1000	mm
Size and Thickness Basis		Actual	
Actual Thickness	tn	8.3820	mm
Corrosion Allowance	can	3.0000	mm
Joint Efficiency of Shell Seam at Nozzle	E1	1.00	
Joint Efficiency of Nozzle Neck	En	1.00	
Outside Projection	ho	47.6250	mm
Weld leg size between Nozzle and Pad/Shell	Wo	6.0000	mm
Groove weld depth between Nozzle and Vessel	Wgnv	8.3400	mm

The Pressure Design option was Design Pressure + static head.

Nozzle Sketch (may not represent actual weld type/configuration)



Abutting/Set-on Nozzle No Pad

Reinforcement CALCULATION, Description: N3

ASME Code, Section VIII, Div. 1, 2019, UG-37 to UG-45

FileName : N2-Inlet_LI4734 -----

Nozzle Calcs.: N3 Nozl: 14 11:19am Apr 13,2022

Actual Outside Diameter Used in Calculation 38.100 mm.
 Actual Thickness Used in Calculation 8.382 mm

Nozzle input data check completed without errors.

Reqd thk per UG-37(a) of Cylindrical Shell, tr [Int. Press]

$$= P \cdot R / (S_v \cdot E - 0.6 \cdot P) \text{ per UG-27 (c) (1)}$$

$$= 1.45 \cdot 155.4 / (117.9 \cdot 1 - 0.6 \cdot 1.45)$$

$$= 1.9250 \text{ mm}$$

Reqd thk per UG-37(a) of Nozzle Wall, trn [Int. Press]

$$= P \cdot R_o / (S_n \cdot E + 0.4 \cdot P) \text{ per Appendix 1-1 (a) (1)}$$

$$= 1.45 \cdot 19.05 / (117.9 \cdot 1 + 0.4 \cdot 1.45)$$

$$= 0.2331 \text{ mm}$$

UG-40, Limits of Reinforcement : [Internal Pressure]

Parallel to Vessel Wall (Diameter Limit)	D1	54.6720	mm
Parallel to Vessel Wall, opening length	d	27.3360	mm
Normal to Vessel Wall (Thickness Limit), no pad	Tlnp	12.7750	mm

Note:

*Taking a UG-36(c)(3)(a) exemption for nozzle: N3.
 This calculation is valid for nozzles that meet all the requirements of paragraph UG-36. Please check the Code carefully, especially for nozzles that are not isolated or do not meet Code spacing requirements. To force the computation of areas for small nozzles go to Tools->Configuration and check the box to force the UG-37 small nozzle area calculation or force the Appendix 1-10 computation in Nozzle Design Options.*

UG-45 Minimum Nozzle Neck Thickness Requirement: [Int. Press.]

Wall Thickness for Internal/External pressures	ta	= 3.2331	mm
Wall Thickness per UG16(b),	tr16b	= 4.5000	mm
Wall Thickness, shell/head, internal pressure	trb1	= 4.9250	mm
Wall Thickness	tb1 = max(trb1, tr16b)	= 4.9250	mm
Wall Thickness	tb2 = max(trb2, tr16b)	= 4.5000	mm
Wall Thickness per table UG-45	tb3	= 6.1200	mm

Determine Nozzle Thickness candidate [tb]:

$$= \min[tb3, \max(tb1, tb2)]$$

$$= \min[6.12, \max(4.925, 4.5)]$$

$$= 4.9250 \text{ mm}$$

Minimum Wall Thickness of Nozzle Necks [tUG-45]:

$$= \max(ta, tb)$$

$$= \max(3.233, 4.925)$$

$$= 4.9250 \text{ mm}$$

Available Nozzle Neck Thickness = 8.3820 mm --> OK

Nozzle Junction Minimum Design Metal Temperature (MDMT) Calculations:

Nozzle-Shell/Head Weld (UCS-66(a)1(b)), Curve: B

Govrn. thk, tg = 8.11, tr = 1.925, c = 3 mm, E* = 1
 Thickness Ratio = tr * (E*) / (tg - c) = 0.377, Temp. Reduction = 58 °C

Min Metal Temp. w/o impact per UCS-66, Curve B	-29 °C
Min Metal Temp. at Required thickness (UCS 66.1)	-48 °C

Gov. MDMT of the nozzle to shell joint welded assembly : -48 °C

Weld Size Calculations, Description: N3

FileName : N2-Inlet_LI4734 -----

Nozzle Calcs.: N3

Noz1: 14 11:19am Apr 13,2022

Intermediate Calc. for nozzle/shell Welds Tmin 5.3820 mm

Results Per UW-16.1:

	Required Thickness	Actual Thickness
Nozzle Weld	$3.7674 = 0.7 * t_{min}$	$4.2420 = 0.7 * W_o$ mm

Skipping the nozzle attachment weld strength calculations.
Per UW-15(b)(2) the nozzles exempted by UG-36(c)(3)(a)
(small nozzles) do not require a weld strength check.

Maximum Allowable Pressure for this Nozzle at this Location:

Converged Max. Allow. Pressure in Operating case 3.204 N/mm²

Note: The MAWP of this junction was limited by the parent Shell/Head.

The Drop for this Nozzle is : 1.1956 mm

The Cut Length for this Nozzle is, Drop + Ho + H + T : 56.9305 mm

PV Elite is a trademark of Hexagon AB, 2021, All rights reserved.

Input, Nozzle Desc: N1

From: 20

Pressure for Reinforcement Calculations	P	1.4500	N/mm ²
Temperature for Internal Pressure	Temp	210	°C
Parent Material		SA-106 B	
Parent Allowable Stress at Temperature	Sv	117.90	N/mm ²
Parent Allowable Stress At Ambient	Sva	117.90	N/mm ²
Inside Diameter of Cylindrical Shell	D	304.74	mm
Shell Finished (Minimum) Thickness	t	8.1100	mm
Shell Internal Corrosion Allowance	c	3.0000	mm
Shell External Corrosion Allowance	co	0.0000	mm
Distance from Bottom/Left Tangent		290.32	mm
User Entered Minimum Design Metal Temperature		-28.89	°C

Type of Element Connected to the Parent : Nozzle

Material		SA-106 B	
Material UNS Number		K03006	
Material Specification/Type		Smls. pipe	
Allowable Stress at Temperature	Sn	117.90	N/mm ²
Allowable Stress At Ambient	Sna	117.90	N/mm ²
Diameter Basis (for tr calc only)		Outside	
Layout Angle		0.00	deg
Diameter		50.0000	mm
Size and Thickness Basis		Nominal	
Nominal Thickness		160	
Flange Material		SA-105	
Flange Type		Weld Neck Flange	
Corrosion Allowance	can	3.0000	mm
Joint Efficiency of Shell Seam at Nozzle	E1	1.00	
Joint Efficiency of Nozzle Neck	En	1.00	
Outside Projection	ho	57.0000	mm
Weld leg size between Nozzle and Pad/Shell	Wo	6.0000	mm
Groove weld depth between Nozzle and Vessel	Wgnv	8.3400	mm
Flange Class		300	
Flange Grade		GR 1.1	

The Pressure Design option was Design Pressure + static head.

Nozzle Sketch (may not represent actual weld type/configuration)

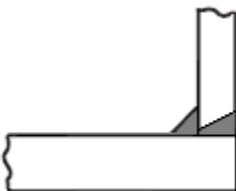

Abutting/Set-on Nozzle No Pad

Reinforcement CALCULATION, Description: N1

ASME Code, Section VIII, Div. 1, 2019, UG-37 to UG-45

Actual Outside Diameter Used in Calculation 60.325 mm.
 Actual Thickness Used in Calculation 8.738 mm

Nozzle input data check completed without errors.

Reqd thk per UG-37(a) of Cylindrical Shell, tr [Int. Press]

$$= P \cdot R / (S_v \cdot E - 0.6 \cdot P) \text{ per UG-27 (c) (1)}$$

$$= 1.45 \cdot 155.4 / (117.9 \cdot 1 - 0.6 \cdot 1.45)$$

$$= 1.9250 \text{ mm}$$

Reqd thk per UG-37(a) of Nozzle Wall, trn [Int. Press]

$$= P \cdot R_o / (S_n \cdot E + 0.4 \cdot P) \text{ per Appendix 1-1 (a) (1)}$$

$$= 1.45 \cdot 30.16 / (117.9 \cdot 1 + 0.4 \cdot 1.45)$$

$$= 0.3691 \text{ mm}$$

UG-40, Limits of Reinforcement : [Internal Pressure]

Parallel to Vessel Wall (Diameter Limit)	D1	97.6996	mm
Parallel to Vessel Wall, opening length	d	48.8498	mm
Normal to Vessel Wall (Thickness Limit), no pad	Tlnp	12.7750	mm

Note:

*Taking a UG-36(c)(3)(a) exemption for nozzle: N1.
 This calculation is valid for nozzles that meet all the requirements of paragraph UG-36. Please check the Code carefully, especially for nozzles that are not isolated or do not meet Code spacing requirements. To force the computation of areas for small nozzles go to Tools->Configuration and check the box to force the UG-37 small nozzle area calculation or force the Appendix 1-10 computation in Nozzle Design Options.*

UG-45 Minimum Nozzle Neck Thickness Requirement: [Int. Press.]

Wall Thickness for Internal/External pressures	ta	= 3.3691	mm
Wall Thickness per UG16(b),	tr16b	= 4.5000	mm
Wall Thickness, shell/head, internal pressure	trb1	= 4.9250	mm
Wall Thickness	tb1 = max(trb1, tr16b)	= 4.9250	mm
Wall Thickness	tb2 = max(trb2, tr16b)	= 4.5000	mm
Wall Thickness per table UG-45	tb3	= 6.4200	mm

Determine Nozzle Thickness candidate [tb]:

$$= \min[tb3, \max(tb1, tb2)]$$

$$= \min[6.42, \max(4.925, 4.5)]$$

$$= 4.9250 \text{ mm}$$

Minimum Wall Thickness of Nozzle Necks [tUG-45]:

$$= \max(ta, tb)$$

$$= \max(3.369, 4.925)$$

$$= 4.9250 \text{ mm}$$

Available Nozzle Neck Thickness = 0.875 * 8.738 = 7.645 mm --> OK

Nozzle Junction Minimum Design Metal Temperature (MDMT) Calculations:

Nozzle Neck to Flange Weld, Curve: B

Govrn. thk, tg = 7.645, tr = 0.369, c = 3 mm, E* = 1
 Thickness Ratio = tr * (E*) / (tg - c) = 0.0795, Temp. Reduction = 78 °C

Min Metal Temp. w/o impact per UCS-66, Curve B -29 °C

PV Elite 23 SP2 Licensee: PPV-Engineering B.V.

FileName : N2-Inlet_LI4734 -----

Nozzle Calcs.: N1 Nozl: 15 11:19am Apr 13,2022

Min Metal Temp. at Required thickness (UCS 66.1) -104 °C

Nozzle-Shell/Head Weld (UCS-66(a)1(b)), Curve: B

Govrn. thk, tg = 7.645, tr = 0.369, c = 3 mm, E* = 1
 Thickness Ratio = $tr * (E^*) / (tg - c) = 0.0795$, Temp. Reduction = 78 °C

Min Metal Temp. w/o impact per UCS-66, Curve B -29 °C
 Min Metal Temp. at Required thickness (UCS 66.1) -104 °C

Gov. MDMT of the nozzle to shell joint welded assembly : -104 °C

ANSI Flange MDMT including Temperature reduction per UCS-66.1:

Unadjusted MDMT of ASME B16.5/47 flanges per UCS-66(c) -18 °C
 Flange MDMT with Temp reduction per UCS-66(b) (1) (-b) -104 °C

Where the Stress Reduction Ratio per UCS-66(b)(1)(-b) is :
 Design Pressure/Ambient Rating = $1.45/5.11 = 0.284$

Weld Size Calculations, Description: N1

Intermediate Calc. for nozzle/shell Welds Tmin 5.7376 mm

Results Per UW-16.1:

	Required Thickness	Actual Thickness
Nozzle Weld	$4.0163 = 0.7 * t_{min}$	$4.2420 = 0.7 * W_o$ mm

Skipping the nozzle attachment weld strength calculations.
 Per UW-15(b)(2) the nozzles exempted by UG-36(c)(3)(a)
 (small nozzles) do not require a weld strength check.

Maximum Allowable Pressure for this Nozzle at this Location:

Converged Max. Allow. Pressure in Operating case 3.204 N/mm²

Note: The MAWP of this junction was limited by the parent Shell/Head.

The Drop for this Nozzle is : 3.0153 mm
 The Cut Length for this Nozzle is, Drop + Ho + H + T : 68.1253 mm

Note: This nozzle or its diameter limit intersects weld seam # [1] on this element. The distance between the nozzle and seam is, 0.00 mm , while the distance from the center of the nozzle to the edge of the diameter limit is: 48.85 mm

PV Elite is a trademark of Hexagon AB, 2021, All rights reserved.