







OWNER:  شرکت سست و سویی توهمه ایرانیان (سایه و شایان)	BUSHEHR PETROCHEMICAL COMPANY MEG PLANT							EPC CONTRACTOR:  Chagalesh-Enerechimi-Steam Joint Venture BUPC-MEG PLANT PROJECT	
	PULSATION DAMPER MECHANICAL STRENGHT CALCULATION FOR EMERGENCY INSTRUMENT AIR COMPRESSOR							 Netherlands	
MC :  شرکت سست و سویی توهمه ایرانیان (سایه و شایان)	Project	Area	Phase	Unit	Dis.	Doc.	Seq.	Contract No : 52-98/445	
Owner Document Number: 17811-24D	BU	20	VD	303	ME	CAL	0078	Rev.:	Page
								01	1 of 60

Repetitive comment:  
Wind and seismic (as per ASCE 7-16 (see report in page 13 of requisition)) effect for design all pressure vessels (even if located inside of package) shall be considered by vendor.

## PULSATION DAMPER MECHANICAL STRENGHT CALCULATION FOR EMERGENCY INSTRUMENT AIR COMPRESSOR

 شرکت سست و سویی توهمه ایرانیان شرکت سست و سویی توهمه ایرانیان (سایه و شایان)	 Chagalesh-Enerechimi-Steam Joint Venture BUPC-MEG PLANT PROJECT	BUSHEHR PETROCHEMICAL COMPANY MEG PLANT
<b>Document Review</b>		
Issue Purpose:	IFA	
Result Code: AP,AN,CM,RE,NC	CM	
Next Status : IFC,IFA,IFI,AFC,AB	IFA	
Responsible Department	MECHANICAL	
Commented Date	May/12/2022	
<b>Approval or review hereunder shall not be construed to relieve Vendor / Subcontractor of his responsibilities and liability under the contract.</b>		

		<b>Issue For Approval</b>				
01	09/05/2022	<del>For Information</del>	KP	CL	JR	
00	26/04/2022	<del>For Information</del>	KP	CL	JR	
<b>Rev.</b>	<b>Date</b>	<b>Purpose of Issue</b>	<b>Prepared</b>	<b>Checked</b>	<b>Approved</b>	<b>AC Code</b>
					<b>Class: 1</b>	<b>Phase: P</b>



# Report – Instrument air inlet\_LI4731

## **PV-Elite Calculation Summary**

Client: Airpack Nederland BV.  
Client location: Zierikzee  
Ref number client: 17811-OO-0702(KP)

### **PPV Engineering**

Author: H.Hoezen  
- Telephone: +31 (0)594 581010  
- E-mail: h.hoezen@ppv-engineering.nl

April 19, 2022  
Order number: P22-115-01  
Document number: 22-11501-C05  
Revision: 0

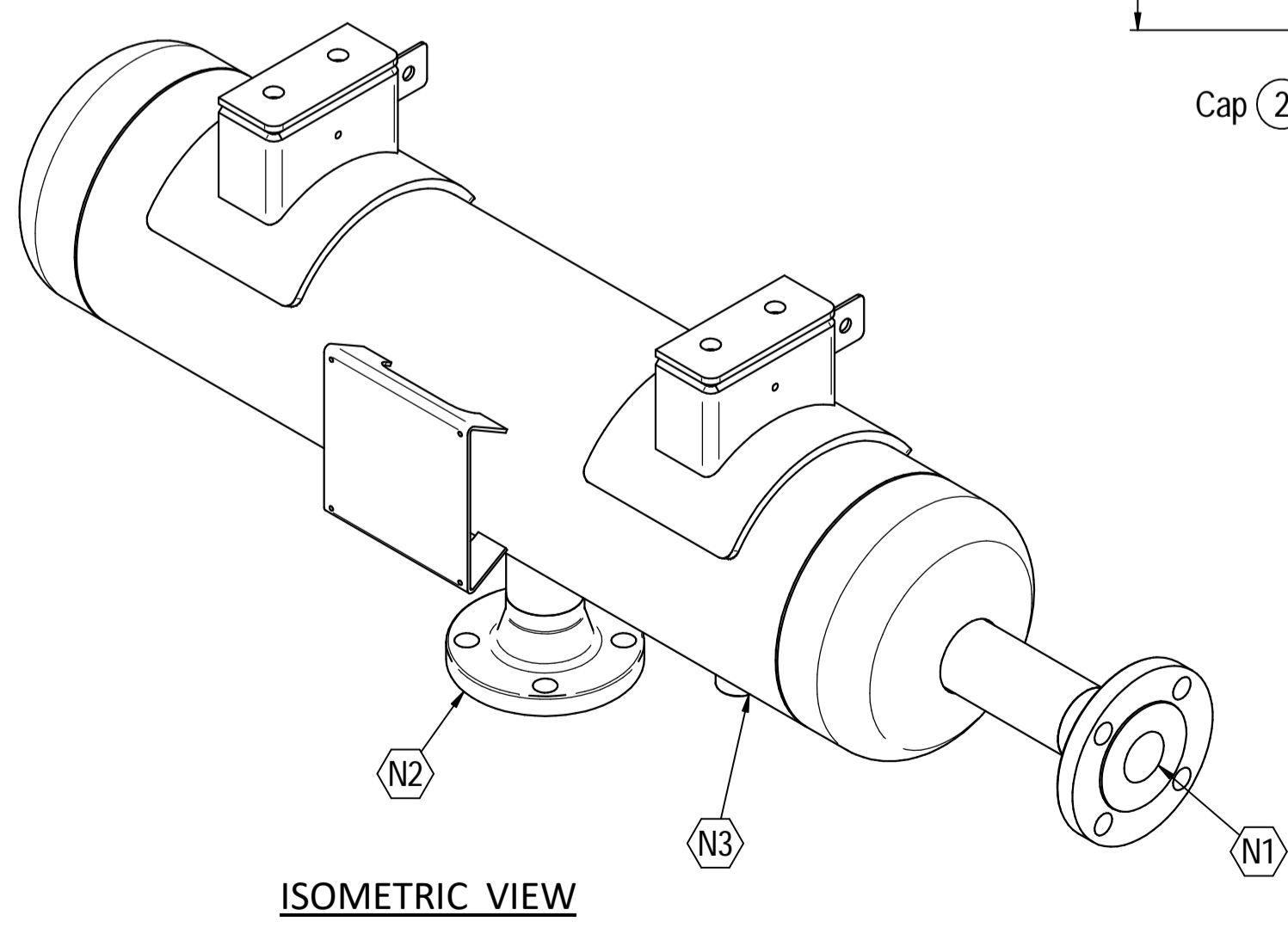
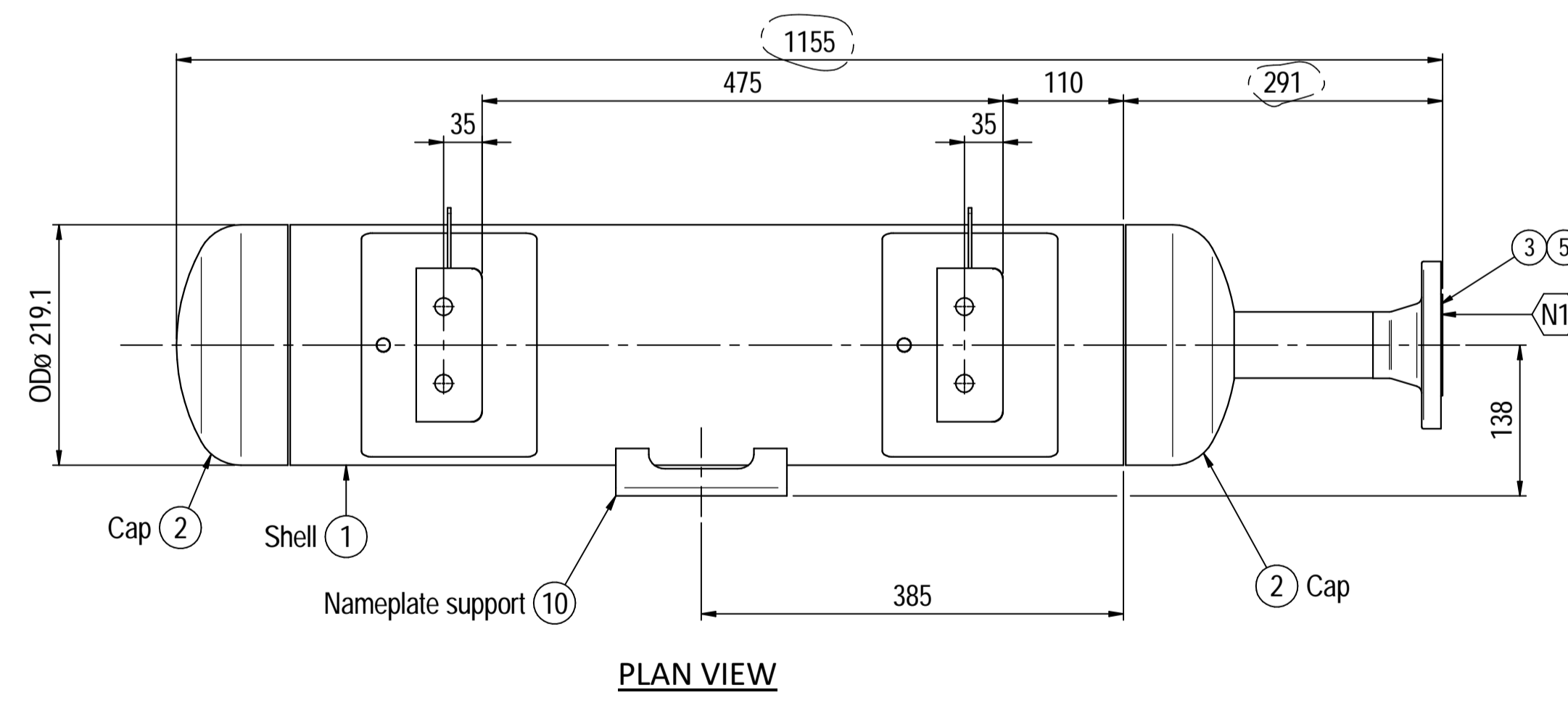
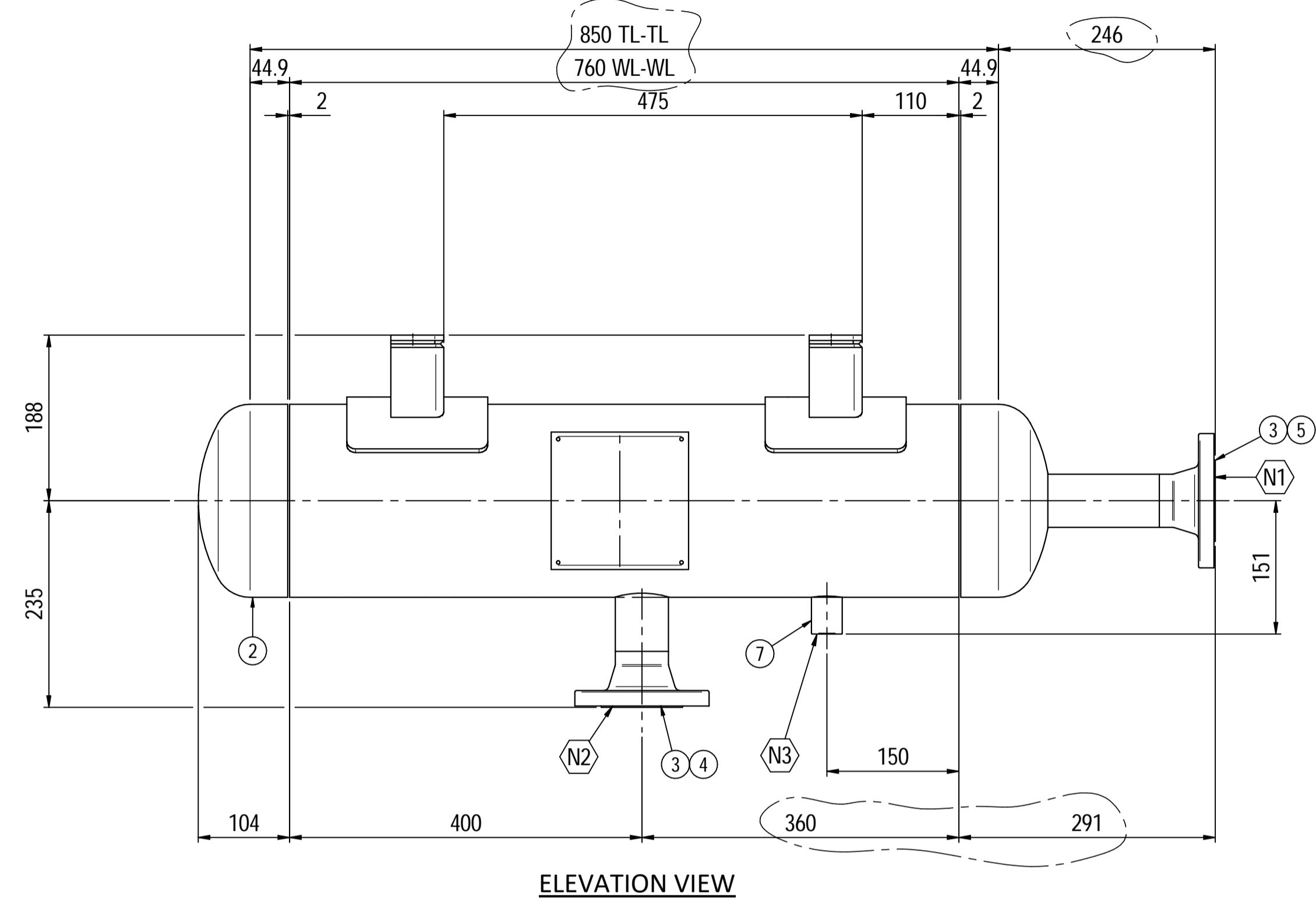
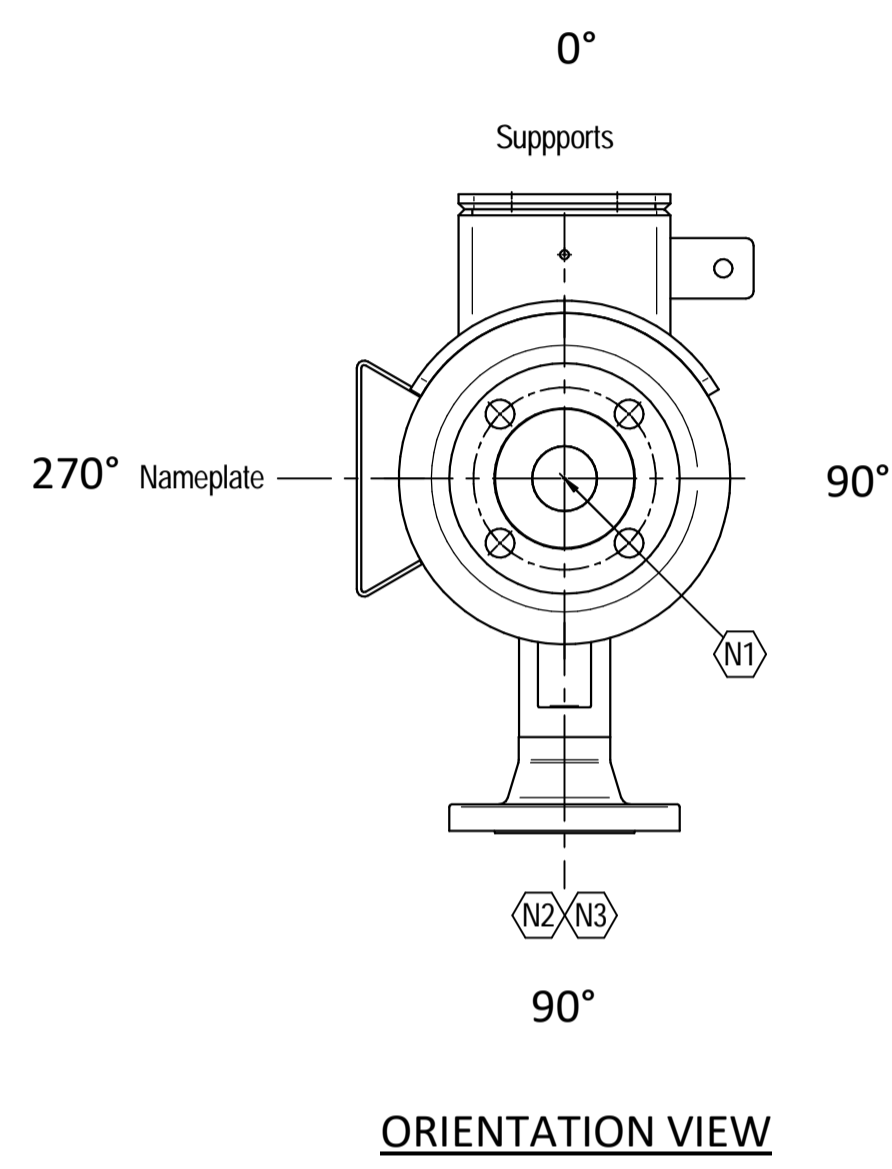
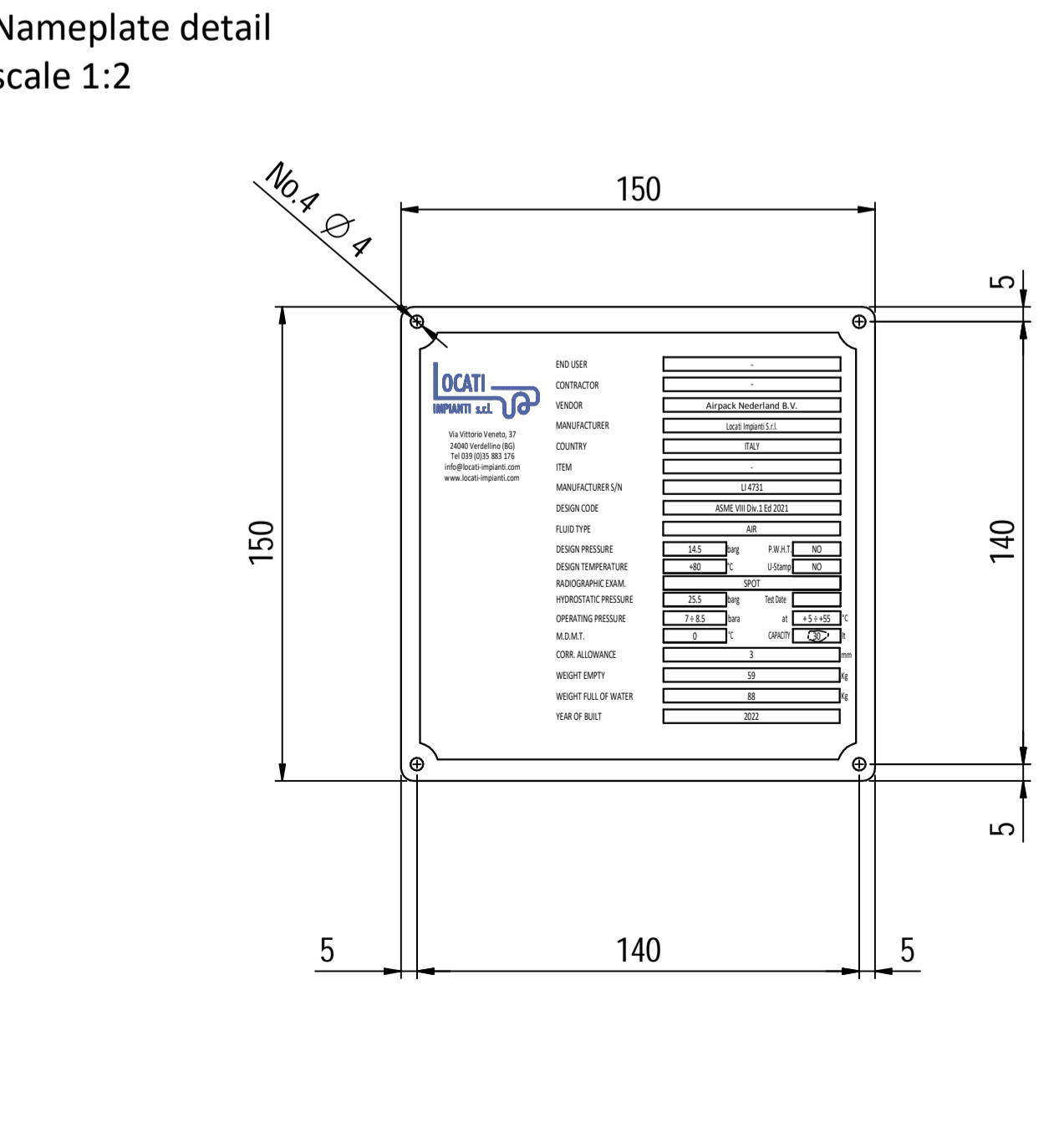
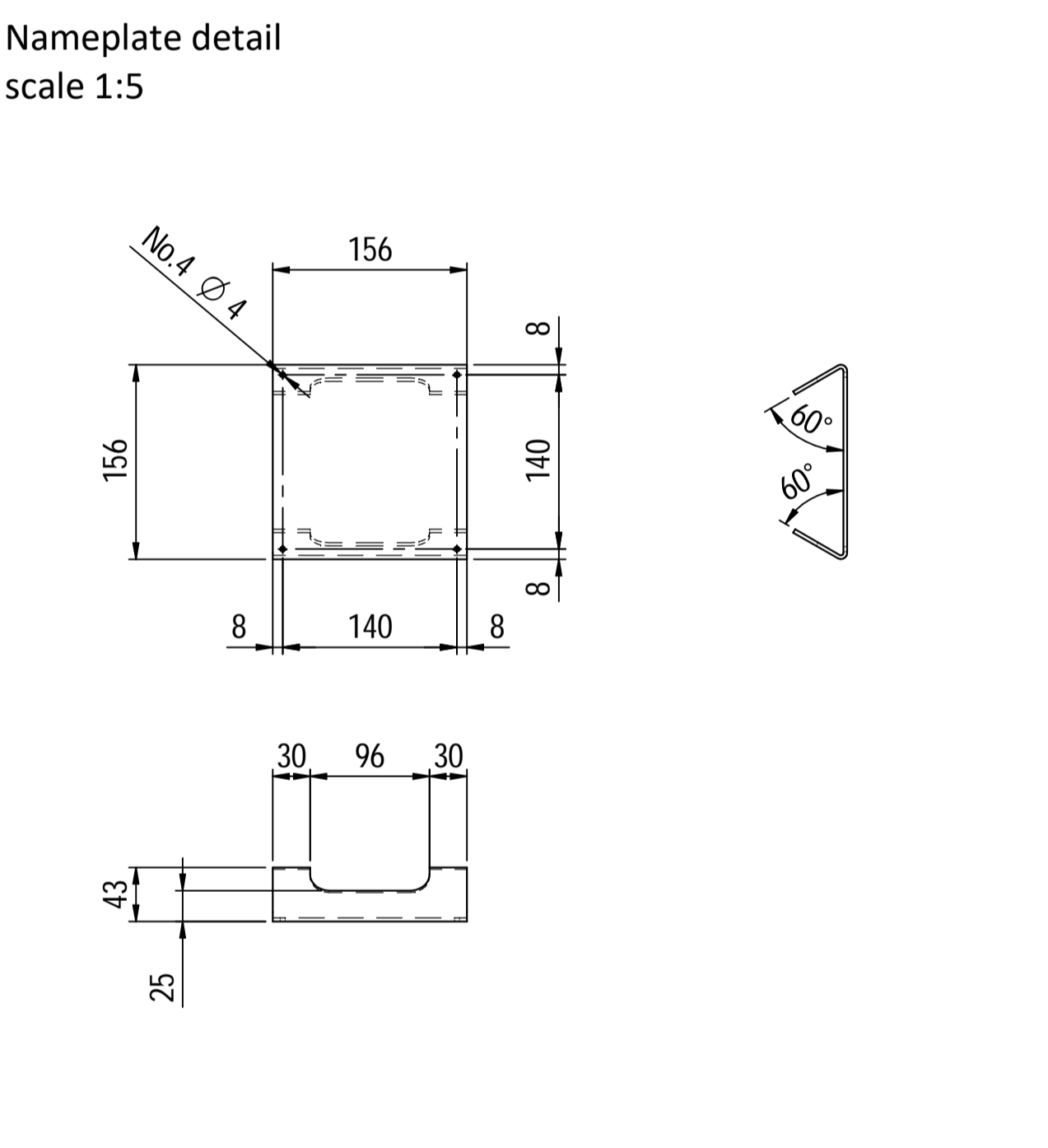
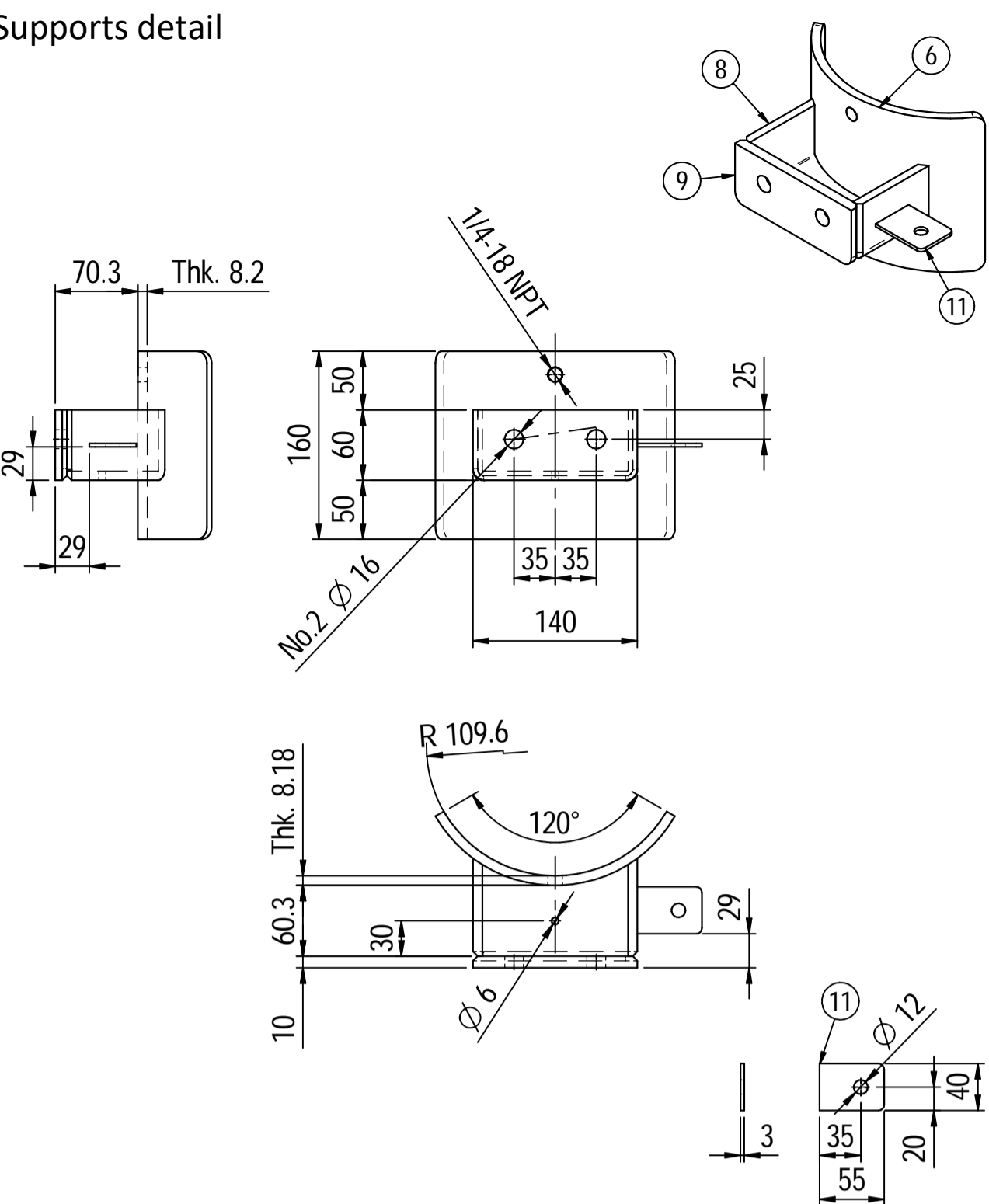

Material List					
Pos.	Q.ty	Description	Mat.	Cert.	
1	1	Shell by seamless pipe 8" Sch.40L=760	A106 Gr.B	3.1	
2	2	Cap 8" Sch40	A234 WPB	3.1	
3	2	Flange 2" WN 150# Sch160	SA105	3.1	
4	1	Seamless pipe 2" Sch160 L=74	A106 Gr.B	3.1	
5	1	Seamless pipe 2" Sch160 L=72	A106 Gr.B	3.1	
6	2	Pad by pipe 8" Sch.40	A106 Gr.B	3.1	
7	1	Coupling 1/2" NPT #6000	A105	3.1	
8	2	Plate 83x231 Thk.8	A516 70	3.1	
9	2	Plate 60x140 Thk.10	A516 70	3.1	
10	1	Nameplate support 156x241 Thk.3mm	A516 70	3.1	
11	2	Earthing Plate 55 x 40 Thk.3	A240 TP316L	3.1	

Note:  
 1) Governing measurement S.I. unless otherwise specified;  
 2) Flange bolt holes have to be straddled from main vessel center line in plan & vertical & horizontal centreline in elevation;  
 3) Material: certification 3.1 EN 10204;  
 4) All internal edge shall be rounded off;  
 5) Nozzle fittings in accordance with ASME B16.5: 2013;  
 6) Flange fittings in accordance with ASME B16.9: 2012;  
 7) The flange dimensions are in accordance to ASME B16.5: 2013;  
 8) All fillet welds not detailed on "WELDING MAP" or drawing shall have the weld; throated equal to 0,7 times the minimum thickness to be welded;  
 9) All welds are continuous except where indicate;  
 10) See document C220006CLC007 for vessel calculation.

ITEM	QTY	SERVICE	SIZE	O.D.	THK	RATING	TYPE	FACE	O.D.	THK.	Tc
N3	1	DRAIN	1/2"	38.1	8.38	#6000	-	NPT-F	-	-	8.5 ± 10
N2	1	AIR OUTLET	2"	60.3	8.74	#150	WN	RF	-	-	8.5 ± 10
N1	1	AIR INLET	2"	60.3	8.74	#150	WN	RF	-	-	8.5 ± 10

DATI DI PROGETTO / Design data			
FLUIDO	Air	COLLAUDO	Test
STATO FISICO DEL FLUIDO	Gas	NATIONAL BOARD REGISTRATION	NO
STATO FISICO DEL FLUIDO	Gas	NATIONAL BOARD REGISTRATION	NO
CODICE DI CALCOLO	ASME VIII Div. 1 Ed.2021	CANADIAN REGISTER NUMBER	NO
PRESSIONE DI ESERCIZIO	7 - 8.5 bara	SERVIZIO LETALE	NO
PRESSIONE DI PROGETTO	14.5 barg	X-RAY	RT examination
PRESSIONE ESTERNA	NO	LIQUIDI PENETRANTI	NO
PRESSIONE DI PROVA IDRAULICA	25.5 barg	Dye penetrant extension	NO
TEMPERATURA DI ESERCIZIO	5 + 55°C	ULTRASUONI	NO
TEMPERATURA DI PROGETTO	80 °C	Hydraulic test pressure	Ultrasonic extension
SOVRAMETALLO DI CORROSIONE	3 mm	CONTROLLO MAGNETOSCOPICO	NO
CAPACITA'	30 l	Magnetic particle examination	NO
EFFICIENZA GIUNTI	0.85	WELDING MAP	NO
MAWP @ Design Temperature	18.3 barg @ +80°C	PROCEDIMENTO DI SALDATURA	See doc: C220006WBK013
MAWP(EXT)	NO	TIPO DI FONDO	Cap
MDMT @ MAWP	0 °C @ 18.3 barg	FORMAZIONE FONDO	HOT
TRATTAMENTO TERMICO	NO	PESO A VUOTO	59 kg
P.W.H.T.	NO	PESO IN ESERCIZIO	59 kg
IMPACT TEST	NO	PESO PIENO D'ACQUA	88 kg
		Full water weight	
		DATI DEL VENTO	
		Wind data	
		DATI SISMICI	
		Seismological data	

Rev.	Descrizione / Description	Disegnato/Draw	Controllato/Checked	Approvato/Approved	Data/Date
02	Modified as per Customer comments	CM	MV	GL	02/04/2022
01	Modified earthing lug	CM	MV	GL	25/03/2022
00	FIRST ISSUE	CM	MV	GL	16/03/2022

Objetto/Object: PULSATION DAMPER INLET

Scala/Scale	1 : 5	Formato/Size	A1
Comm. N°/Job No.	C220006	Foglio/Sheet	1 - 1
Cliente/Customer	Airpack Nederland B.V.		
Ord. No.	18498-VV-0901		
Dis. N°/Dwg No.	C220006DWG001	Rev.	02

## DESIGN CALCULATION

*In Accordance with ASME Section VIII Division 1*

ASME Code Version : 2019

Analysis Performed by : PPV-Engineering B.V.

Job File : P:\2\_ENGINEERING\PROJ-2022\P22-115-AIRZI\01\_PV E

Date of Analysis : Apr 13,2022 10:25am

PV Elite 23 SP2, October 2021

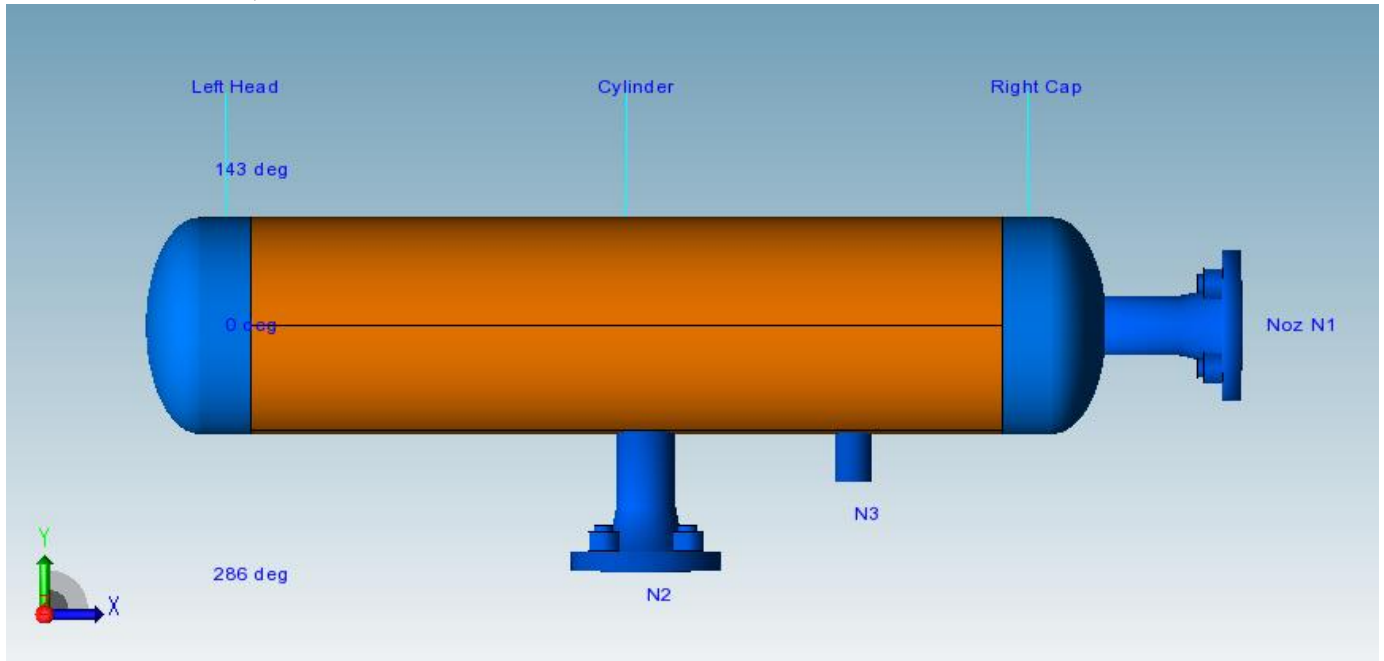

# Table of Contents

Cover Sheet.....	2
Vessel Design Summary:.....	3
Nozzle Summary: .....	5
Nozzle Schedule:.....	6
Bill of Material:.....	7
Input Echo:.....	8
Internal Pressure Calculations: .....	12
Element and Detail Weights:.....	16
Nozzle Flange MAWP:.....	18
Nozzle Calcs.: N2 .....	19
Nozzle Calcs.: N3 .....	22
Nozzle Calcs.: Noz N1.....	25

**Vessel Design Summary:**

**ASME Code, Section VIII Division 1, 2019**

Diameter Spec : 219.100 mm OD	
Vessel Design Length, Tangent to Tangent	862.63 mm
Specified Datum Line Distance	51.31 mm
Internal Design Temperature	80 °C
Internal Design Pressure	1.450 N/mm <sup>2</sup>
External Design Temperature	80 °C
Maximum Allowable Working Pressure	1.83 N/mm <sup>2</sup>
Shop Test Pressure	2.550 N/mm <sup>2</sup>
Required Minimum Design Metal Temperature	-28.9 °C
Warmest Computed Minimum Design Metal Temperature	-32.0 °C
Wind Design Code	No Wind Loads
Earthquake Design Code	No Seismic

**Materials of Construction:**

Component Type	Material	Class	Thickness	UNS #	Normal ized	Impact Tested
Shell	SA-106 B	...	...	K03006	No	No
Head	SA-234 WPB	...	...	K03006	No	No
Nozzle	SA-106 B	...	...	K03006	No	No
Nozzle Flg	SA-105	...	...	K03504	No	No

Normalized is determined based on the UCS-66 material curve selection and Figure UCS-66.  
 Impact Tested is based on material selection and material data properties.

**Element Pressures and MAWP (N/mm<sup>2</sup> & mm):**

Element Description or Type	Design Pressure + Stat. head	Ext. Press.	Element M.A.W.P	Total Corrosion Allowance	Str. Flg. Gov.	In Creep Range
Left Head	1.450	0.00	4.830	3.0000	Yes	No
Cylinder	1.450	0.00	3.864	3.0000	N/A	No
Right Cap	1.450	0.00	4.830	3.0000	Yes	No

**Element Types and Properties:**

Element Type	"To" Elev mm	Element Length mm	Nominal Thickness mm	Finished Thickness mm	Reqd Thk Internal mm	Reqd Thk External mm	Long Eff	Circ Eff
Ellipse	0.0	51.3	8.2	8.2	4.5	4.5	0.85	0.85
Cylinder	760.0	760.0	8.2	7.2	4.6	...	0.85	0.85
Ellipse	811.3	51.3	8.2	8.2	4.5	4.5	0.85	0.85

**Weights:**

Fabricated - Bare W/O Removable Internals	51.8 kgm
Shop Test - Fabricated + Water ( Full )	82.4 kgm
Shipping - Fab. + Rem. Intls.+ Shipping App.	51.8 kgm
Erected - Fab. + Rem. Intls.+ Insul. (etc)	51.8 kgm
Empty - Fab. + Intls. + Details + Wghts.	51.8 kgm

PV Elite 23 SP2 Licensee: PPV-Engineering B.V.

FileName : Instrument air inlet\_LI4731 -----

Vessel Design Summary: Step: 15 10:25am Apr 13,2022

Operating - Empty + Operating Liquid (No CA)	51.8	kgm
Field Test - Empty Weight + Water (Full)	82.4	kgm

**PV Elite is a trademark of Hexagon AB, 2021, All rights reserved.**

FileName : Instrument air inlet\_LI4731 -----

Nozzle Summary: Step: 13 10:25am Apr 13,2022

**Nozzle Calculation Summary:**

Description	MAWP N/mm <sup>2</sup>	Ext	MAPNC N/mm <sup>2</sup>	UG-45	[tr] mm	Weld Path	Areas or Stresses
N2	3.864	...	...	OK	4.50	OK	No Calc[*]
N3	3.864	...	...	OK	4.50	OK	No Calc[*]
Noz N1	4.83	...	...	OK	4.50	OK	No Calc[*]

**Nozzle MAWP Summary:**

Minimum MAWP Nozzles : 3.864 Nozzle : N3  
 Minimum MAWP Shells/Flanges : 1.83 N/mm<sup>2</sup>  
 -----  
 Computed Vessel M.A.W.P. : 1.83 N/mm<sup>2</sup>

[\*] - This was a small opening and the areas were not computed.

Note: MAWPs (Internal Case) shown above are at the High Point.

**Check the Spatial Relationship between the Nozzles:**

From Node	Nozzle Description	X Coordinate mm	Layout Angle deg	Dia. Limit mm
20	N2	451.315	270.000	97.700
20	N3	661.315	270.000	54.672
30	Noz N1	0.000	0.000	97.700

**The nozzle spacing is computed by the following:**

= Sqrt( ll<sup>2</sup> + lc<sup>2</sup> ) where

ll - Arc length along the inside vessel surface in the long. direction.

lc - Arc length along the inside vessel surface in the circ. direction

If any interferences/violations are found, they will be noted below.

No interference violations have been detected!

PV Elite is a trademark of Hexagon AB, 2021, All rights reserved.

FileName : Instrument air inlet\_LI4731 -----

Nozzle Schedule: Step: 12 10:25am Apr 13,2022

**Nozzle Schedule:**

Description	Nominal or Actual Size	Schd or FVC Type	Flg Type	Nozzle O/Dia mm	Wall Thk mm	Reinforcing Diameter	Pad Thk mm	Cut Length mm	Flg Class
N3	38 mm Actual		Non	38.1	8.4	...	...	5	...
N2	50 mm	160	WN	60.3	8.7	...	...	8	150
Noz N1	50 mm	160	WN	60.3	8.7	...	...	8	150

*General Notes for the above table:*

The Cut Length is the Outside Projection + Inside Projection + Drop + In Plane Shell Thickness. This value does not include weld gaps, nor does it account for shrinkage.

In the case of Oblique Nozzles, the Outside Diameter must be increased. The Re-Pad WIDTH around the nozzle is calculated as follows:  
 Width of Pad = (Pad Outside Dia. (per above) - Nozzle Outside Dia.)/2

For hub nozzles, the thickness and diameter shown are those of the smaller and thinner section.

**Nozzle Material and Weld Fillet Leg Size Details (mm):**

Description	Material	Shl Grve Weld	Noz Shl/Pad Weld	Pad OD Weld	Pad Grve Weld	Inside Weld
N3	SA-106 B	8.340	6.000	...	...	...
N2	SA-106 B	8.340	6.000	...	...	...
Noz N1	SA-106 B	7.160	6.000	...	...	...

Note: The Outside projections below do not include the flange thickness.

**Nozzle Miscellaneous Data:**

Description	Elev/Distance From Datum mm	Layout Angle deg	Proj Outside mm	Proj Inside mm	Installed in Component
N3	610.000	270.0	47.62	0.00	Cylinder
N2	400.000	270.0	74.00	0.00	Cylinder
Noz N1	...	0.0	72.00	0.00	Right Cap

PV Elite is a trademark of Hexagon AB, 2021, All rights reserved.

PV Elite 23 SP2 Licensee: PPV-Engineering B.V.

FileName : Instrument air inlet\_LI4731 -----

Bill of Material: Step: 11 10:25am Apr 13,2022

**Bill of Materials:**

QTY	DESCRIPTION	MATERIAL
2	ELLIPTICAL HEAD: 2.0 X 1, 8.2mm THK X 202.7mm ID X 51.3mm	SA-234 WPB
2	CYLINDRICAL SEGMENT 8.2mm THK X 255.5mm X 760.0mm	SA-106 B
1	CYLINDRICAL SEGMENT 8.2mm THK X 132.2mm X 760.0mm	SA-106 B
1	NAMEPLATE	...

PV Elite is a trademark of Hexagon AB, 2021, All rights reserved.

**PV Elite Vessel Analysis Program: Input Data**

Design Internal Pressure (for Hydrotest)	1.45	N/mm <sup>2</sup>
Design Internal Temperature	80.0	°C
Projection of Nozzle from Vessel Top	0	mm
Projection of Nozzle from Vessel Bottom	0	mm
Minimum Design Metal Temperature	-28.9	°C
Type of Construction	Welded	
Special Service	None	
Degree of Radiography	RT-3	
Use Higher Longitudinal Stresses (Flag)	Y	
Select t for Internal Pressure (Flag)	N	
Select t for External Pressure (Flag)	N	
Select t for Axial Stress (Flag)	N	
Select Location for Stiff. Rings (Flag)	N	
Consider Vortex Shedding	N	
Perform a Corroded Hydrotest	N	

**Shop Pressure Test:**

Type of Pressure Test	User Entered Pressure
Pressure Test Position	Horizontal

Load Case 1	NP+EW+WI+FW+BW
Load Case 2	NP+EW+EE+FS+BS
Load Case 3	NP+OW+WI+FW+BW
Load Case 4	NP+OW+EQ+FS+BS
Load Case 5	NP+HW+HI
Load Case 6	NP+HW+HE
Load Case 7	IP+OW+WI+FW+BW
Load Case 8	IP+OW+EQ+FS+BS
Load Case 9	EP+OW+WI+FW+BW
Load Case 10	EP+OW+EQ+FS+BS
Load Case 11	HP+HW+HI
Load Case 12	HP+HW+HE
Load Case 13	IP+WE+EW
Load Case 14	IP+WF+CW
Load Case 15	IP+VO+OW
Load Case 16	IP+VE+EW
Load Case 17	NP+VO+OW
Load Case 18	FS+BS+IP+OW
Load Case 19	FS+BS+EP+OW

Wind Design Code No Wind Loads

Seismic Design Code No Seismic

Design Pressure + Static Head	Y
Consider MAP New and Cold in Noz. Design	N
Consider External Loads for Nozzle Des.	Y
Use ASME VIII-1 Appendix 1-9	N

Material Database Year Current w/Addenda or Code Year

**Configuration Directives:**

Do not use Nozzle MDMT Interpretation VIII-1 01-37	No
Use Table G instead of exact equation for "A"	Yes
Shell Head Joints are Tapered	Yes
Compute "K" in corroded condition	Yes
Use Code Case 2286	No
Use the MAWP to compute the MDMT	Yes
For thickness ratios <= 0.35, MDMT will be -155F (-104C)	Yes
For PWHT & P1 Materials the MDMT can be < -55F (-48C)	No

FileName : Instrument air inlet\_LI4731 -----

Input Echo: Step: 1 10:25am Apr 13,2022

Using Metric Material Databases, ASME II D No  
 Calculate B31.3 type stress for Nozzles with Loads Yes  
 Reduce the MDMT due to lower membrane stress Yes  
 Consider Longitudinal Stress in MDMT calcs. (Div. 1) Yes

**Complete Listing of Vessel Elements and Details:**

Element From Node 10  
 Element To Node 20  
 Element Type Elliptical  
 Description Left Head  
 Distance "FROM" to "TO" 51.315 mm  
 Element Outside Diameter 219.1 mm  
 Element Thickness 8.18 mm  
 Internal Corrosion Allowance 3 mm  
 Nominal Thickness 8.18 mm  
 External Corrosion Allowance 0 mm  
 Design Internal Pressure 1.45 N/mm<sup>2</sup>  
 Design Temperature Internal Pressure 80 °C  
 Design External Pressure 0 N/mm<sup>2</sup>  
 Design Temperature External Pressure 80 °C  
 Effective Diameter Multiplier 1.2  
 Material Name SA-234 WPB  
     Allowable Stress, Ambient 117.9 N/mm<sup>2</sup>  
     Allowable Stress, Operating 117.9 N/mm<sup>2</sup>  
     Allowable Stress, Hydrotest 153.27 N/mm<sup>2</sup>  
     Material Density 7750.4 kg/m<sup>3</sup>  
     P Number Thickness 30.988 mm  
     Yield Stress, Operating 223.97 N/mm<sup>2</sup>  
     UCS-66 Chart Curve Designation B  
     External Pressure Chart Name CS-2  
     UNS Number K03006  
     Product Form Smls. & wld. fittings  
 Efficiency, Longitudinal Seam 0.85  
 Efficiency, Circumferential Seam 0.85  
 Elliptical Head Factor 2.0  
 Weld is pre-Heated No

-----  
 Element From Node 20  
 Element To Node 30  
 Element Type Cylinder  
 Description Cylinder  
 Distance "FROM" to "TO" 760 mm  
 Element Outside Diameter 219.1 mm  
 Element Thickness 7.16 mm  
 Internal Corrosion Allowance 3 mm  
 Nominal Thickness 8.18 mm  
 External Corrosion Allowance 0 mm  
 Design Internal Pressure 1.45 N/mm<sup>2</sup>  
 Design Temperature Internal Pressure 80 °C  
 Design External Pressure 0 N/mm<sup>2</sup>  
 Design Temperature External Pressure 80 °C  
 Effective Diameter Multiplier 1.2  
 Material Name SA-106 B  
     Allowable Stress, Ambient 117.9 N/mm<sup>2</sup>  
     Allowable Stress, Operating 117.9 N/mm<sup>2</sup>  
     Allowable Stress, Hydrotest 153.27 N/mm<sup>2</sup>  
     Material Density 7750.4 kg/m<sup>3</sup>  
     P Number Thickness 30.988 mm  
     Yield Stress, Operating 223.97 N/mm<sup>2</sup>  
     UCS-66 Chart Curve Designation B  
     External Pressure Chart Name CS-2

FileName : Instrument air inlet\_LI4731 -----

Input Echo: Step: 1 10:25am Apr 13,2022

UNS Number	K03006
Product Form	Smls. pipe
Efficiency, Longitudinal Seam	0.85
Efficiency, Circumferential Seam	0.85
Weld is pre-Heated	No

Element From Node	20
Detail Type	Nozzle
Detail ID	N2
Dist. from "FROM" Node / Offset dist	400 mm
Nozzle Diameter	50 mm
Nozzle Schedule	160
Nozzle Class	150
Layout Angle	270.0
Blind Flange (Y/N)	N
Weight of Nozzle ( Used if > 0 )	0 N
Grade of Attached Flange	GR 1.1
Nozzle Matl	SA-106 B

Element From Node	20
Detail Type	Nozzle
Detail ID	N3
Dist. from "FROM" Node / Offset dist	610 mm
Nozzle Diameter	38.1 mm
Nozzle Schedule	None
Nozzle Class	None
Layout Angle	270.0
Blind Flange (Y/N)	N
Weight of Nozzle ( Used if > 0 )	0 N
Grade of Attached Flange	None
Nozzle Matl	SA-106 B

-----

Element From Node	30
Element To Node	40
Element Type	Elliptical
Description	Right Cap
Distance "FROM" to "TO"	51.315 mm
Element Outside Diameter	219.1 mm
Element Thickness	8.18 mm
Internal Corrosion Allowance	3 mm
Nominal Thickness	8.18 mm
External Corrosion Allowance	0 mm
Design Internal Pressure	1.45 N/mm <sup>2</sup>
Design Temperature Internal Pressure	80 °C
Design External Pressure	0 N/mm <sup>2</sup>
Design Temperature External Pressure	80 °C
Effective Diameter Multiplier	1.2
Material Name	SA-234 WPB
Allowable Stress, Ambient	117.9 N/mm <sup>2</sup>
Allowable Stress, Operating	117.9 N/mm <sup>2</sup>
Allowable Stress, Hydrotest	153.27 N/mm <sup>2</sup>
Material Density	7750.4 kg/m <sup>3</sup>
P Number Thickness	30.988 mm
Yield Stress, Operating	223.97 N/mm <sup>2</sup>
UCS-66 Chart Curve Designation	B
External Pressure Chart Name	CS-2
UNS Number	K03006
Product Form	Smls. & wld. fittings
Efficiency, Longitudinal Seam	0.85
Efficiency, Circumferential Seam	0.85
Elliptical Head Factor	2.0
Weld is pre-Heated	No

FileName : Instrument air inlet\_LI4731 -----

Input Echo: Step: 1 10:25am Apr 13,2022

Element From Node	30
Detail Type	Nozzle
Detail ID	Noz N1
Dist. from "FROM" Node / Offset dist	0 mm
Nozzle Diameter	50 mm
Nozzle Schedule	160
Nozzle Class	150
Layout Angle	0.0
Blind Flange (Y/N)	N
Weight of Nozzle ( Used if > 0 )	0 N
Grade of Attached Flange	GR 1.1
Nozzle Matl	SA-106 B

**PV Elite is a trademark of Hexagon AB, 2021, All rights reserved.**

**Internal Pressure Results Summary:**

**Element Thickness, Pressure, Diameter and Allowable Stress :**

From	To	Int. Press + Liq. Hd N/mm <sup>2</sup>	Nominal Thickness mm	Total Corr Allowance mm	Element Diameter mm	Allowable Stress (SE) N/mm <sup>2</sup>
Left Head		1.45	8.18	3	219.1	100.22
Cylinder		1.45	8.18	3	219.1	100.22
Right Cap		1.45	8.18	3	219.1	100.22

**Element Required Thickness and MAWP :**

From	To	Design Pressure N/mm <sup>2</sup>	M.A.W.P. Corroded N/mm <sup>2</sup>	M.A.P. New & Cold N/mm <sup>2</sup>	Minimum Thickness mm	Required Thickness mm
Left Head		1.45	4.83	8.022	8.18	4.508
Cylinder		1.45	3.864	6.726	7.16	4.57594
Right Cap		1.45	4.83	8.022	8.18	4.508
Minimum			1.83	1.96		

Note : The M.A.W.P is Governed by a Standard Flange !

Note : The M.A.P.(NC) is Governed by a Flange !

Elements Suitable for Design Internal Pressure.

**Internal Pressure Calculation Results:**

**ASME Code, Section VIII Division 1, 2019**

**Elliptical Head From 10 To 20 SA-234 WPB , UCS-66 Crv. B at 80 °C**

Left Head

Material UNS Number: K03006

Required Thickness due to Internal Pressure [tr]:

$$= (P \cdot Do \cdot K_{cor}) / (2 \cdot S \cdot E + 2 \cdot P \cdot (K_{cor} - 0.1)) \text{ per Appendix 1-4 (c)}$$

$$= (1.45 \cdot 219.1 \cdot 0.963) / (2 \cdot 117.9 \cdot 0.85 + 2 \cdot 1.45 \cdot (0.963 - 0.1))$$

$$= 1.5080 + 3.0000 = 4.5080 \text{ mm}$$

Max. Allowable Working Pressure at given Thickness, corroded [MAWP]:

$$= (2 \cdot S \cdot E \cdot t) / (K_{cor} \cdot Do - 2 \cdot t \cdot (K_{cor} - 0.1)) \text{ per Appendix 1-4 (c)}$$

$$= (2 \cdot 117.9 \cdot 0.85 \cdot 5.18) / (0.963 \cdot 219.1 - 2 \cdot 5.18 \cdot (0.963 - 0.1))$$

$$= 5.137 \text{ N/mm}^2$$

Maximum Allowable Pressure, New and Cold [MAPNC]:

$$= (2 \cdot S \cdot E \cdot t) / (K \cdot Do - 2 \cdot t \cdot (K - 0.1)) \text{ per Appendix 1-4 (c)}$$

$$= (2 \cdot 117.9 \cdot 0.85 \cdot 8.18) / (1 \cdot 219.1 - 2 \cdot 8.18 \cdot (1 - 0.1))$$

$$= 8.022 \text{ N/mm}^2$$

Actual stress at given pressure and thickness, corroded [Sact]:

$$= (P \cdot (K_{cor} \cdot Do - 2 \cdot t \cdot (K_{cor} - 0.1))) / (2 \cdot E \cdot t)$$

$$= (1.45 \cdot (0.963 \cdot 219.1 - 2 \cdot 5.18 \cdot (0.963 - 0.1))) / (2 \cdot 0.85 \cdot 5.18)$$

$$= 33.279 \text{ N/mm}^2$$

Straight Flange Required Thickness:

$$= (P \cdot Ro) / (S \cdot E + 0.4 \cdot P) + ca \text{ per Appendix 1-1 (a) (1)}$$

$$= (1.45 \cdot 109.5) / (117.9 \cdot 0.85 + 0.4 \cdot 1.45) + 3$$

PV Elite 23 SP2 Licensee: PPV-Engineering B.V.

FileName : Instrument air inlet\_LI4731 -----

Internal Pressure Calculations: Step: 3 10:25am Apr 13,2022

$$= 4.576 \text{ mm}$$

Straight Flange Maximum Allowable Working Pressure:

$$\begin{aligned} &= (S \cdot E \cdot t) / (R_o - 0.4 \cdot t) \text{ per Appendix 1-1 (a) (1)} \\ &= (117.9 \cdot 0.85 \cdot 5.18) / (109.5 - 0.4 \cdot 5.18) \\ &= 4.83 \text{ N/mm}^2 \end{aligned}$$

Factor K, corroded condition [Kcor]:

$$\begin{aligned} &= (2 + (\text{Inside Diameter} / (2 \cdot \text{Inside Head Depth}))^2) / 6 \\ &= (2 + (208.7 / (2 \cdot 53.68))^2) / 6 \\ &= 0.963266 \end{aligned}$$

**MDMT Calculations in the Knuckle Portion:**

Govrn. thk,  $t_g = 8.18$ ,  $t_r = 1.897$ ,  $c = 3$  mm,  $E^* = 0.85$   
Thickness Ratio =  $t_r \cdot (E^*) / (t_g - c) = 0.311$ , Temp. Reduction = 78 °C

Min Metal Temp. w/o impact per UCS-66, Curve B -29 °C  
Min Metal Temp. at Required thickness (UCS 66.1) -104 °C

**MDMT Calculations in the Head Straight Flange:**

Govrn. thk,  $t_g = 8.18$ ,  $t_r = 1.986$ ,  $c = 3$  mm,  $E^* = 0.85$   
Thickness Ratio =  $t_r \cdot (E^*) / (t_g - c) = 0.326$ , Temp. Reduction = 78 °C

Min Metal Temp. w/o impact per UCS-66, Curve B -29 °C  
Min Metal Temp. at Required thickness (UCS 66.1) -104 °C

**Cylindrical Shell From 20 To 30 SA-106 B, UCS-66 Crv. B at 80 °C**

Cylinder

Longitudinal Joint: Seamless

Material UNS Number: K03006

Required Thickness due to Internal Pressure [tr]:

$$\begin{aligned} &= (P \cdot R_o) / (S \cdot E + 0.4 \cdot P) \text{ per Appendix 1-1 (a) (1)} \\ &= (1.45 \cdot 109.5) / (117.9 \cdot 0.85 + 0.4 \cdot 1.45) \\ &= 1.5759 + 3.0000 = 4.5759 \text{ mm} \end{aligned}$$

Max. Allowable Working Pressure at given Thickness, corroded [MAWP]:

$$\begin{aligned} &= (S \cdot E \cdot t) / (R_o - 0.4 \cdot t) \text{ per Appendix 1-1 (a) (1)} \\ &= (117.9 \cdot 0.85 \cdot 4.16) / (109.5 - 0.4 \cdot 4.16) \\ &= 3.864 \text{ N/mm}^2 \end{aligned}$$

Maximum Allowable Pressure, New and Cold [MAPNC]:

$$\begin{aligned} &= (S \cdot E \cdot t) / (R_o - 0.4 \cdot t) \text{ per Appendix 1-1 (a) (1)} \\ &= (117.9 \cdot 0.85 \cdot 7.16) / (109.5 - 0.4 \cdot 7.16) \\ &= 6.726 \text{ N/mm}^2 \end{aligned}$$

Actual stress at given pressure and thickness, corroded [Sact]:

$$\begin{aligned} &= (P \cdot (R_o - 0.4 \cdot t)) / (E \cdot t) \\ &= (1.45 \cdot ((109.5 - 0.4 \cdot 4.16))) / (0.85 \cdot 4.16) \\ &= 44.241 \text{ N/mm}^2 \end{aligned}$$

**Minimum Design Metal Temperature Results:**

Govrn. thk,  $t_g = 7.16$ ,  $t_r = 0.959$ ,  $c = 3$  mm,  $E^* = 0.85$   
Thickness Ratio =  $t_r \cdot (E^*) / (t_g - c) = 0.196$ , Temp. Reduction = 78 °C

Min Metal Temp. w/o impact per UCS-66, Curve B -29 °C  
Min Metal Temp. at Required thickness (UCS 66.1) -104 °C

**Elliptical Head From 30 To 40 SA-234 WPB, UCS-66 Crv. B at 80 °C**

Right Cap  
 Material UNS Number: K03006

Required Thickness due to Internal Pressure [tr]:  
 $= (P \cdot Do \cdot K_{cor}) / (2 \cdot S \cdot E + 2 \cdot P \cdot (K_{cor} - 0.1))$  per Appendix 1-4 (c)  
 $= (1.45 \cdot 219.1 \cdot 0.963) / (2 \cdot 117.9 \cdot 0.85 + 2 \cdot 1.45 \cdot (0.963 - 0.1))$   
 $= 1.5080 + 3.0000 = 4.5080 \text{ mm}$

Max. Allowable Working Pressure at given Thickness, corroded [MAWP]:  
 $= (2 \cdot S \cdot E \cdot t) / (K_{cor} \cdot Do - 2 \cdot t \cdot (K_{cor} - 0.1))$  per Appendix 1-4 (c)  
 $= (2 \cdot 117.9 \cdot 0.85 \cdot 5.18) / (0.963 \cdot 219.1 - 2 \cdot 5.18 \cdot (0.963 - 0.1))$   
 $= 5.137 \text{ N/mm}^2$

Maximum Allowable Pressure, New and Cold [MAPNC]:  
 $= (2 \cdot S \cdot E \cdot t) / (K \cdot Do - 2 \cdot t \cdot (K - 0.1))$  per Appendix 1-4 (c)  
 $= (2 \cdot 117.9 \cdot 0.85 \cdot 8.18) / (1 \cdot 219.1 - 2 \cdot 8.18 \cdot (1 - 0.1))$   
 $= 8.022 \text{ N/mm}^2$

Actual stress at given pressure and thickness, corroded [Sact]:  
 $= (P \cdot (K_{cor} \cdot Do - 2 \cdot t \cdot (K_{cor} - 0.1))) / (2 \cdot E \cdot t)$   
 $= (1.45 \cdot (0.963 \cdot 219.1 - 2 \cdot 5.18 \cdot (0.963 - 0.1))) / (2 \cdot 0.85 \cdot 5.18)$   
 $= 33.279 \text{ N/mm}^2$

Straight Flange Required Thickness:  
 $= (P \cdot Ro) / (S \cdot E + 0.4 \cdot P) + ca$  per Appendix 1-1 (a) (1)  
 $= (1.45 \cdot 109.5) / (117.9 \cdot 0.85 + 0.4 \cdot 1.45) + 3$   
 $= 4.576 \text{ mm}$

Straight Flange Maximum Allowable Working Pressure:  
 $= (S \cdot E \cdot t) / (Ro - 0.4 \cdot t)$  per Appendix 1-1 (a) (1)  
 $= (117.9 \cdot 0.85 \cdot 5.18) / (109.5 - 0.4 \cdot 5.18)$   
 $= 4.83 \text{ N/mm}^2$

Factor K, corroded condition [Kcor]:  
 $= (2 + (\text{Inside Diameter} / (2 \cdot \text{Inside Head Depth}))^2) / 6$   
 $= (2 + (208.7 / (2 \cdot 53.68))^2) / 6$   
 $= 0.963266$

**MDMT Calculations in the Knuckle Portion:**

Govrn. thk, tg = 8.18, tr = 1.897, c = 3 mm, E\* = 0.85  
 Thickness Ratio = tr \* (E\*) / (tg - c) = 0.311, Temp. Reduction = 78 °C

Min Metal Temp. w/o impact per UCS-66, Curve B -29 °C  
 Min Metal Temp. at Required thickness (UCS 66.1) -104 °C

**MDMT Calculations in the Head Straight Flange:**

Govrn. thk, tg = 8.18, tr = 1.986, c = 3 mm, E\* = 0.85  
 Thickness Ratio = tr \* (E\*) / (tg - c) = 0.326, Temp. Reduction = 78 °C

Min Metal Temp. w/o impact per UCS-66, Curve B -29 °C  
 Min Metal Temp. at Required thickness (UCS 66.1) -104 °C

Note: Heads and Shells Exempted to -20F (-29C) by paragraph UG-20F

**Hydrostatic Test Pressure Results:**

Pressure per UG99b	= 1.30 * M.A.W.P. * Sa/S	2.379	N/mm <sup>2</sup>
Pressure per UG99b[35]	= 1.30 * Design Pres * Sa/S	1.885	N/mm <sup>2</sup>
Pressure per UG99c	= 1.30 * M.A.P. - Head(Hyd)	2.548	N/mm <sup>2</sup>
Pressure per UG100	= 1.10 * M.A.W.P. * Sa/S	2.013	N/mm <sup>2</sup>

PV Elite 23 SP2 Licensee: PPV-Engineering B.V.

FileName : Instrument air inlet\_LI4731 -----

Internal Pressure Calculations: Step: 3 10:25am Apr 13,2022

Pressure per PED = max(1.43\*DP, 1.25\*DP\*ratio) 2.073 N/mm<sup>2</sup>  
 Pressure per App 27-4 = M.A.W.P. 1.830 N/mm<sup>2</sup>  
 User Defined Hydrostatic Test Pressure at High Point 2.550 N/mm<sup>2</sup>

#### Horizontal Test performed per: User Hydro Pressure

*Please note that Nozzle, Shell, Head, Flange, etc MAWPs are all considered when determining the hydrotest pressure for those test types that are based on the MAWP of the vessel.*

#### Stresses on Elements due to Test Pressure (N/mm<sup>2</sup>):

From To	Stress	Allowable	Ratio	Pressure
Left Head	37.5	153.3	0.245	2.55
Cylinder	44.7	153.3	0.292	2.55
Right Cap	37.5	153.3	0.245	2.55

#### Stress ratios for Nozzle and Pad Materials (N/mm<sup>2</sup>):

Description	Pad/Nozzle	Ambient	Operating	Ratio
N2	Nozzle	117.90	117.90	1.000
N3	Nozzle	117.90	117.90	1.000
Noz N1	Nozzle	117.90	117.90	1.000
Minimum				1.000

#### Stress ratios for Pressurized Vessel Elements (N/mm<sup>2</sup>):

Description	Ambient	Operating	Ratio
Left Head	117.90	117.90	1.000
Cylinder	117.90	117.90	1.000
Right Cap	117.90	117.90	1.000
Minimum			1.000

#### Hoop Stress in Nozzle Wall during Pressure Test (N/mm<sup>2</sup>):

Description	Ambient	Operating	Ratio
N2	7.79	153.27	0.051
N3	4.78	153.27	0.031
Noz N1	7.79	153.27	0.051

Elements Suitable for Test Pressure.

PV Elite is a trademark of Hexagon AB, 2021, All rights reserved.

**Element and Detail Weights:**

From	To	Element Metal Wgt. kgm	Element ID Volume m³	Corroded Metal Wgt. kgm	Corroded ID Volume m³	Extra due Misc %
10	20	5.5314	0.0027479	3.50277	0.0029472	...
20	30	32.2363	0.025036	20.7012	0.026524	...
30	40	5.5314	0.0027479	3.50277	0.0029472	...
Total		43	0.03	27	0.03	0

**Weight of Details:**

From	Type	Weight of Detail kgm	X Offset, Dtl. Cent. mm	Y Offset, Dtl. Cent. mm	Z Offset, Dtl. Cent. mm	Description
20	Noz1	4.14184	400	-132.552	...	N2
20	Noz1	0.28886	610	-121.44	...	N3
30	Noz1	4.1201	102	...	...	Noz N1

**Total Weight of Each Detail Type:**

Nozzles	8.6
Sum of the Detail Weights	8.6 kgm

**Weight Summation Results: (kgm)**

	Fabricated	Shop Test	Shipping	Erected	Empty	Operating
Main Elements	43.3	43.3	43.3	43.3	43.3	43.3
Nozzles	8.6	8.6	8.6	8.6	8.6	8.6
Test Liquid	...	30.5	...	...	...	...
Totals	51.8	82.4	51.8	51.8	51.8	51.8

**Weight Summary:**

Fabricated Wt.	- Bare Weight without Removable Internals	51.8 kgm
Shop Test Wt.	- Fabricated Weight + Water ( Full )	82.4 kgm
Shipping Wt.	- Fab. Weight + removable Intls.+ Shipping App.	51.8 kgm
Erected Wt.	- Fab. Wt + or - loose items (trays,platforms etc.)	51.8 kgm
Ope. Wt. no Liq	- Fab. Weight + Internals. + Details + Weights	51.8 kgm
Operating Wt.	- Empty Weight + Operating Liq. Uncorroded	51.8 kgm
Oper. Wt. + CA	- Corr Wt. + Operating Liquid	36.3 kgm
Field Test Wt.	- Empty Weight + Water (Full)	82.4 kgm

**Note:**

The Corroded Weight and thickness are used in the Horizontal Vessel Analysis (Ope Case) and Earthquake Load Calculations.

**Outside Surface Areas of Elements:**

From	To	Surface Area cm²
10	20	873.578
20	30	5279.96
30	40	873.578

PV Elite 23 SP2 Licensee: PPV-Engineering B.V.

FileName : Instrument air inlet\_LI4731 -----

Element and Detail Weights: Step: 5 10:25am Apr 13,2022

-----  
Total 7027.118 cm<sup>2</sup>

**PV Elite is a trademark of Hexagon AB, 2021, All rights reserved.**

FileName : Instrument air inlet\_LI4731 -----

Nozzle Flange MAWP: Step: 6 10:25am Apr 13,2022

**Nozzle Flange MAWP Results: (N/mm<sup>2</sup> & °C)**

Nozzle Description	Flange Rating		Design Temp	Class	Grade/Group	Equiv. Press	Max Pressure			
	Ope.	Ambient					UG-44 (b)	50%	DNV	
N2	1.83	1.96	80	150	GR 1.1	...	...	...	...	
Noz N1	1.83	1.96	80	150	GR 1.1	...	...	...	...	
Min Rating	1.830	1.960	N/mm <sup>2</sup> [for Core Elements]				0.000	0.000	0.000	

Pressure Ratings are per ASME B16.5 2013 Metric Edition

PV Elite is a trademark of Hexagon AB, 2021, All rights reserved.

**Input, Nozzle Desc: N2 From: 20**

Pressure for Reinforcement Calculations	P	1.4500	N/mm <sup>2</sup>
Temperature for Internal Pressure	Temp	80	°C
Parent Material		SA-106 B	
Parent Allowable Stress at Temperature	Sv	117.90	N/mm <sup>2</sup>
Parent Allowable Stress At Ambient	Sva	117.90	N/mm <sup>2</sup>
Inside Diameter of Cylindrical Shell	D	202.74	mm
Shell Finished (Minimum) Thickness	t	7.1600	mm
Shell Internal Corrosion Allowance	c	3.0000	mm
Shell External Corrosion Allowance	co	0.0000	mm
Distance from Bottom/Left Tangent		451.31	mm
User Entered Minimum Design Metal Temperature		-28.89	°C

**Type of Element Connected to the Parent : Nozzle**

Material		SA-106 B	
Material UNS Number		K03006	
Material Specification/Type		Smls. pipe	
Allowable Stress at Temperature	Sn	117.90	N/mm <sup>2</sup>
Allowable Stress At Ambient	Sna	117.90	N/mm <sup>2</sup>
Diameter Basis (for tr calc only)		Outside	
Layout Angle		270.00	deg
Diameter		50.0000	mm
Size and Thickness Basis		Nominal	
Nominal Thickness		160	
Flange Material		SA-105	
Flange Type		Weld Neck Flange	
Corrosion Allowance	can	3.0000	mm
Joint Efficiency of Shell Seam at Nozzle	E1	1.00	
Joint Efficiency of Nozzle Neck	En	1.00	
Outside Projection	ho	74.0000	mm
Weld leg size between Nozzle and Pad/Shell	Wo	6.0000	mm
Groove weld depth between Nozzle and Vessel	Wgnv	8.3400	mm
Flange Class		150	
Flange Grade		GR 1.1	

The Pressure Design option was Design Pressure + static head.

**Nozzle Sketch (may not represent actual weld type/configuration)**

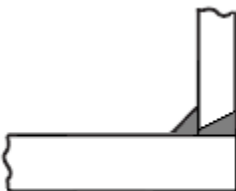

**Abutting/Set-on Nozzle No Pad**

PV Elite 23 SP2 Licensee: PPV-Engineering B.V.  
 FileName : Instrument air inlet\_LI4731 -----  
 Nozzle Calcs.: N2 Nozl: 13 10:25am Apr 13,2022

### Reinforcement CALCULATION, Description: N2

ASME Code, Section VIII, Div. 1, 2019, UG-37 to UG-45

Actual Outside Diameter Used in Calculation 60.325 mm.  
 Actual Thickness Used in Calculation 8.738 mm

Nozzle input data check completed without errors.

Reqd thk per UG-37(a) of Cylindrical Shell, tr [Int. Press]

$$= P \cdot R / (S_v \cdot E - 0.6 \cdot P) \text{ per UG-27 (c) (1)}$$

$$= 1.45 \cdot 104.4 / (117.9 \cdot 1 - 0.6 \cdot 1.45)$$

$$= 1.2931 \text{ mm}$$

Reqd thk per UG-37(a) of Nozzle Wall, trn [Int. Press]

$$= P \cdot R_o / (S_n \cdot E + 0.4 \cdot P) \text{ per Appendix 1-1 (a) (1)}$$

$$= 1.45 \cdot 30.16 / (117.9 \cdot 1 + 0.4 \cdot 1.45)$$

$$= 0.3691 \text{ mm}$$

### UG-40, Limits of Reinforcement : [Internal Pressure]

Parallel to Vessel Wall (Diameter Limit) D1 97.6996 mm  
 Parallel to Vessel Wall, opening length d 48.8498 mm  
 Normal to Vessel Wall (Thickness Limit), no pad Tlnp 10.4000 mm

Note:

*Taking a UG-36(c)(3)(a) exemption for nozzle: N2.  
 This calculation is valid for nozzles that meet all the requirements of  
 paragraph UG-36. Please check the Code carefully, especially for nozzles  
 that are not isolated or do not meet Code spacing requirements. To force  
 the computation of areas for small nozzles go to Tools->Configuration  
 and check the box to force the UG-37 small nozzle area calculation or  
 force the Appendix 1-10 computation in Nozzle Design Options.*

### UG-45 Minimum Nozzle Neck Thickness Requirement: [Int. Press.]

Wall Thickness for Internal/External pressures ta = 3.3691 mm  
 Wall Thickness per UG16(b), tr16b = 4.5000 mm  
 Wall Thickness, shell/head, internal pressure trb1 = 4.2931 mm  
 Wall Thickness tb1 = max(trb1, tr16b) = 4.5000 mm  
 Wall Thickness tb2 = max(trb2, tr16b) = 4.5000 mm  
 Wall Thickness per table UG-45 tb3 = 6.4200 mm

Determine Nozzle Thickness candidate [tb]:

$$= \min[ tb3, \max( tb1, tb2 ) ]$$

$$= \min[ 6.42, \max( 4.5, 4.5 ) ]$$

$$= 4.5000 \text{ mm}$$

Minimum Wall Thickness of Nozzle Necks [tUG-45]:

$$= \max( ta, tb )$$

$$= \max( 3.369, 4.5 )$$

$$= 4.5000 \text{ mm}$$

Available Nozzle Neck Thickness =  $0.875 \cdot 8.738 = 7.645 \text{ mm}$  --> OK

### Nozzle Junction Minimum Design Metal Temperature (MDMT) Calculations:

#### Nozzle Neck to Flange Weld, min( Curve:B, Curve:A)

Govrn. thk, tg = 7.645, tr = 0.369, c = 3 mm, E\* = 1  
 Thickness Ratio =  $tr \cdot (E^*) / (tg - c) = 0.0795$ , Temp. Reduction = 78 °C

Min Metal Temp. w/o impact per UCS-66, Curve A -8 °C

PV Elite 23 SP2 Licensee: PPV-Engineering B.V.

FileName : Instrument air inlet\_LI4731 -----

Nozzle Calcs.: N2 Nozl: 13 10:25am Apr 13,2022

Min Metal Temp. at Required thickness (UCS 66.1) -104 °C  
 Min Metal Temp. w/o impact per UG-20(f) -29 °C

**Nozzle-Shell/Head Weld (UCS-66(a)(b)), Curve: B**

Govrn. thk, tg = 7.16, tr = 1.293, c = 3 mm, E\* = 1  
 Thickness Ratio =  $tr * (E*) / (tg - c) = 0.311$ , Temp. Reduction = 78 °C

Min Metal Temp. w/o impact per UCS-66, Curve B -29 °C  
 Min Metal Temp. at Required thickness (UCS 66.1) -104 °C

Gov. MDMT of the nozzle to shell joint welded assembly : -104 °C

**ANSI Flange MDMT including Temperature reduction per UCS-66.1:**

Unadjusted MDMT of ASME B16.5/47 flanges per UCS-66(c) -18 °C  
 Flange MDMT with Temp reduction per UCS-66(b)(1)(-b) -32 °C

Where the Stress Reduction Ratio per UCS-66(b)(1)(-b) is :

Design Pressure/Ambient Rating =  $1.45 / 1.96 = 0.740$

Weld Size Calculations, Description: N2

Intermediate Calc. for nozzle/shell Welds Tmin 5.1800 mm

**Results Per UW-16.1:**

	Required Thickness	Actual Thickness
Nozzle Weld	$3.6260 = 0.7 * t_{min}$	$4.2420 = 0.7 * W_o$ mm

Skipping the nozzle attachment weld strength calculations.  
 Per UW-15(b)(2) the nozzles exempted by UG-36(c)(3)(a)  
 (small nozzles) do not require a weld strength check.

**Maximum Allowable Pressure for this Nozzle at this Location:**

Converged Max. Allow. Pressure in Operating case 3.864 N/mm<sup>2</sup>

Note: The MAWP of this junction was limited by the parent Shell/Head.

The Drop for this Nozzle is : 4.5914 mm

The Cut Length for this Nozzle is, Drop + Ho + H + T : 85.7514 mm

Note: This nozzle or its diameter limit intersects weld seam # [3] on this element. The distance between the nozzle and seam is, 29.15 mm , while the distance from the center of the nozzle to the edge of the diameter limit is: 48.85 mm

**PV Elite is a trademark of Hexagon AB, 2021, All rights reserved.**

**Input, Nozzle Desc: N3 From: 20**

Pressure for Reinforcement Calculations	P	1.4500	N/mm <sup>2</sup>
Temperature for Internal Pressure	Temp	80	°C
Parent Material		SA-106 B	
Parent Allowable Stress at Temperature	Sv	117.90	N/mm <sup>2</sup>
Parent Allowable Stress At Ambient	Sva	117.90	N/mm <sup>2</sup>
Inside Diameter of Cylindrical Shell	D	202.74	mm
Shell Finished (Minimum) Thickness	t	7.1600	mm
Shell Internal Corrosion Allowance	c	3.0000	mm
Shell External Corrosion Allowance	co	0.0000	mm
Distance from Bottom/Left Tangent		661.32	mm
User Entered Minimum Design Metal Temperature		-28.89	°C

**Type of Element Connected to the Parent : Nozzle**

Material		SA-106 B	
Material UNS Number		K03006	
Material Specification/Type		Smls. pipe	
Allowable Stress at Temperature	Sn	117.90	N/mm <sup>2</sup>
Allowable Stress At Ambient	Sna	117.90	N/mm <sup>2</sup>
Diameter Basis (for tr calc only)		Outside	
Layout Angle		270.00	deg
Diameter		38.1000	mm
Size and Thickness Basis		Actual	
Actual Thickness	tn	8.3820	mm
Corrosion Allowance	can	3.0000	mm
Joint Efficiency of Shell Seam at Nozzle	E1	1.00	
Joint Efficiency of Nozzle Neck	En	1.00	
Outside Projection	ho	47.6250	mm
Weld leg size between Nozzle and Pad/Shell	Wo	6.0000	mm
Groove weld depth between Nozzle and Vessel	Wgnv	8.3400	mm

The Pressure Design option was Design Pressure + static head.

**Nozzle Sketch (may not represent actual weld type/configuration)**



**Abutting/Set-on Nozzle No Pad**

**Reinforcement CALCULATION, Description: N3**

ASME Code, Section VIII, Div. 1, 2019, UG-37 to UG-45

PV Elite 23 SP2 Licensee: PPV-Engineering B.V.  
 FileName : Instrument air inlet\_LI4731 -----  
 Nozzle Calcs.: N3 Nozl: 14 10:25am Apr 13,2022

Actual Outside Diameter Used in Calculation 38.100 mm.  
 Actual Thickness Used in Calculation 8.382 mm

Nozzle input data check completed without errors.

Reqd thk per UG-37(a) of Cylindrical Shell, tr [Int. Press]

$$= P \cdot R / (S_v \cdot E - 0.6 \cdot P) \text{ per UG-27 (c) (1)}$$

$$= 1.45 \cdot 104.4 / (117.9 \cdot 1 - 0.6 \cdot 1.45)$$

$$= 1.2931 \text{ mm}$$

Reqd thk per UG-37(a) of Nozzle Wall, trn [Int. Press]

$$= P \cdot R_o / (S_n \cdot E + 0.4 \cdot P) \text{ per Appendix 1-1 (a) (1)}$$

$$= 1.45 \cdot 19.05 / (117.9 \cdot 1 + 0.4 \cdot 1.45)$$

$$= 0.2331 \text{ mm}$$

**UG-40, Limits of Reinforcement : [Internal Pressure]**

Parallel to Vessel Wall (Diameter Limit)	D1	54.6720	mm
Parallel to Vessel Wall, opening length	d	27.3360	mm
Normal to Vessel Wall (Thickness Limit), no pad	Tlnp	10.4000	mm

Note:

*Taking a UG-36(c)(3)(a) exemption for nozzle: N3.  
 This calculation is valid for nozzles that meet all the requirements of  
 paragraph UG-36. Please check the Code carefully, especially for nozzles  
 that are not isolated or do not meet Code spacing requirements. To force  
 the computation of areas for small nozzles go to Tools->Configuration  
 and check the box to force the UG-37 small nozzle area calculation or  
 force the Appendix 1-10 computation in Nozzle Design Options.*

**UG-45 Minimum Nozzle Neck Thickness Requirement: [Int. Press.]**

Wall Thickness for Internal/External pressures	ta	= 3.2331	mm
Wall Thickness per UG16(b),	tr16b	= 4.5000	mm
Wall Thickness, shell/head, internal pressure	trb1	= 4.2931	mm
Wall Thickness	tb1 = max(trb1, tr16b)	= 4.5000	mm
Wall Thickness	tb2 = max(trb2, tr16b)	= 4.5000	mm
Wall Thickness per table UG-45	tb3	= 6.1200	mm

Determine Nozzle Thickness candidate [tb]:

$$= \min[ tb3, \max( tb1, tb2 ) ]$$

$$= \min[ 6.12, \max( 4.5, 4.5 ) ]$$

$$= 4.5000 \text{ mm}$$

Minimum Wall Thickness of Nozzle Necks [tUG-45]:

$$= \max( ta, tb )$$

$$= \max( 3.233, 4.5 )$$

$$= 4.5000 \text{ mm}$$

Available Nozzle Neck Thickness = 8.3820 mm --> OK

**Nozzle Junction Minimum Design Metal Temperature (MDMT) Calculations:**

**Nozzle-Shell/Head Weld (UCS-66(a)(b)), Curve: B**

-----  
 Govern. thk, tg = 7.16, tr = 1.293, c = 3 mm, E\* = 1  
 Thickness Ratio = tr \* (E\*) / (tg - c) = 0.311, Temp. Reduction = 78 °C

Min Metal Temp. w/o impact per UCS-66, Curve B	-29 °C
Min Metal Temp. at Required thickness (UCS 66.1)	-104 °C

Gov. MDMT of the nozzle to shell joint welded assembly : -104 °C

Weld Size Calculations, Description: N3

Intermediate Calc. for nozzle/shell Welds Tmin 5.1800 mm

**Results Per UW-16.1:**

	Required Thickness	Actual Thickness
Nozzle Weld	$3.6260 = 0.7 * t_{min}$	$4.2420 = 0.7 * W_o$ mm

Skipping the nozzle attachment weld strength calculations.  
Per UW-15(b)(2) the nozzles exempted by UG-36(c)(3)(a)  
(small nozzles) do not require a weld strength check.

**Maximum Allowable Pressure for this Nozzle at this Location:**

Converged Max. Allow. Pressure in Operating case 3.864 N/mm<sup>2</sup>

Note: The MAWP of this junction was limited by the parent Shell/Head.

The Drop for this Nozzle is : 1.8061 mm

The Cut Length for this Nozzle is, Drop + Ho + H + T : 56.5911 mm

**PV Elite is a trademark of Hexagon AB, 2021, All rights reserved.**

FileName : Instrument air inlet\_LI4731 -----

Nozzle Calcs.: Noz N1 Nozl: 15 10:25am Apr 13,2022

**Input, Nozzle Desc: Noz N1 From: 30**

Pressure for Reinforcement Calculations	P	1.4500	N/mm <sup>2</sup>
Temperature for Internal Pressure	Temp	80	°C
Parent Material		SA-234 WPB	
Parent Allowable Stress at Temperature	Sv	117.90	N/mm <sup>2</sup>
Parent Allowable Stress At Ambient	Sva	117.90	N/mm <sup>2</sup>
Inside Diameter of Elliptical Head	D	202.74	mm
Aspect Ratio of Elliptical Head	Ar	2.00	
Head Finished (Minimum) Thickness	t	8.1800	mm
Head Internal Corrosion Allowance	c	3.0000	mm
Head External Corrosion Allowance	co	0.0000	mm
Distance from Head Centerline	L1	0.0000	mm
User Entered Minimum Design Metal Temperature		-28.89	°C

**Type of Element Connected to the Parent : Nozzle**

Material		SA-106 B	
Material UNS Number		K03006	
Material Specification/Type		Smls. pipe	
Allowable Stress at Temperature	Sn	117.90	N/mm <sup>2</sup>
Allowable Stress At Ambient	Sna	117.90	N/mm <sup>2</sup>
Diameter Basis (for tr calc only)		Outside	
Layout Angle		0.00	deg
Diameter		50.0000	mm
Size and Thickness Basis		Nominal	
Nominal Thickness		160	
Flange Material		SA-105	
Flange Type		Weld Neck Flange	
Corrosion Allowance	can	3.0000	mm
Joint Efficiency of Shell Seam at Nozzle	E1	1.00	
Joint Efficiency of Nozzle Neck	En	1.00	
Outside Projection	ho	72.0000	mm
Weld leg size between Nozzle and Pad/Shell	Wo	6.0000	mm
Groove weld depth between Nozzle and Vessel	Wgnv	7.1600	mm
Flange Class		150	
Flange Grade		GR 1.1	

The Pressure Design option was Design Pressure + static head.

**Nozzle Sketch (may not represent actual weld type/configuration)**



PV Elite 23 SP2 Licensee: PPV-Engineering B.V.  
 FileName : Instrument air inlet\_LI4731 -----  
 Nozzle Calcs.: Noz N1 Nozl: 15 10:25am Apr 13,2022

### Abutting/Set-on Nozzle No Pad

### Reinforcement CALCULATION, Description: Noz N1

ASME Code, Section VIII, Div. 1, 2019, UG-37 to UG-45

Actual Outside Diameter Used in Calculation 60.325 mm.  
 Actual Thickness Used in Calculation 8.738 mm

Nozzle input data check completed without errors.

Reqd thk per UG-37(a) of Elliptical Head, tr [Int. Press]  
 =  $P \cdot D \cdot K1 / (2 \cdot Sv \cdot E - 0.2 \cdot P)$  per Appendix 1-4(c)  
 =  $0.876 \cdot 1.45 \cdot 208.7 / (2 \cdot 117.9 \cdot 1 - 0.2 \cdot 1.45)$   
 = 1.1259 mm

Reqd thk per UG-37(a) of Nozzle Wall, trn [Int. Press]  
 =  $P \cdot Ro / (Sn \cdot E + 0.4 \cdot P)$  per Appendix 1-1 (a) (1)  
 =  $1.45 \cdot 30.16 / (117.9 \cdot 1 + 0.4 \cdot 1.45)$   
 = 0.3691 mm

### UG-40, Limits of Reinforcement : [Internal Pressure]

Parallel to Vessel Wall (Diameter Limit)	D1	97.6996	mm
Parallel to Vessel Wall, opening length	d	48.8498	mm
Normal to Vessel Wall (Thickness Limit), no pad	Tlnp	12.9500	mm

Note:

*Taking a UG-36(c)(3)(a) exemption for nozzle: Noz N1.  
 This calculation is valid for nozzles that meet all the requirements of  
 paragraph UG-36. Please check the Code carefully, especially for nozzles  
 that are not isolated or do not meet Code spacing requirements. To force  
 the computation of areas for small nozzles go to Tools->Configuration  
 and check the box to force the UG-37 small nozzle area calculation or  
 force the Appendix 1-10 computation in Nozzle Design Options.*

### UG-45 Minimum Nozzle Neck Thickness Requirement: [Int. Press.]

Wall Thickness for Internal/External pressures	ta	= 3.3691	mm
Wall Thickness per UG16(b),	tr16b	= 4.5000	mm
Wall Thickness, shell/head, internal pressure	trb1	= 4.2380	mm
Wall Thickness	tb1 = max(trb1, tr16b)	= 4.5000	mm
Wall Thickness	tb2 = max(trb2, tr16b)	= 4.5000	mm
Wall Thickness per table UG-45	tb3	= 6.4200	mm

Determine Nozzle Thickness candidate [tb]:

= min[ tb3, max( tb1, tb2 ) ]  
 = min[ 6.42, max( 4.5, 4.5 ) ]  
 = 4.5000 mm

Minimum Wall Thickness of Nozzle Necks [tUG-45]:

= max( ta, tb )  
 = max( 3.369, 4.5 )  
 = 4.5000 mm

Available Nozzle Neck Thickness =  $0.875 \cdot 8.738 = 7.645$  mm --> OK

### Nozzle Junction Minimum Design Metal Temperature (MDMT) Calculations:

#### Nozzle Neck to Flange Weld, Curve: B

Govrn. thk, tg = 7.645, tr = 0.369, c = 3 mm, E\* = 1  
 Thickness Ratio =  $tr \cdot (E^*) / (tg - c) = 0.0795$ , Temp. Reduction = 78 °C

PV Elite 23 SP2 Licensee: PPV-Engineering B.V.

FileName : Instrument air inlet\_LI4731 -----

Nozzle Calcs.: Noz N1 Nozl: 15 10:25am Apr 13,2022

Min Metal Temp. w/o impact per UCS-66, Curve B -29 °C  
 Min Metal Temp. at Required thickness (UCS 66.1) -104 °C

**Nozzle-Shell/Head Weld (UCS-66(a)1(b)), Curve: B**

Govrn. thk, tg = 7.645, tr = 0.369, c = 3 mm, E\* = 1  
 Thickness Ratio =  $tr * (E*) / (tg - c) = 0.0795$ , Temp. Reduction = 78 °C

Min Metal Temp. w/o impact per UCS-66, Curve B -29 °C  
 Min Metal Temp. at Required thickness (UCS 66.1) -104 °C

Gov. MDMT of the nozzle to shell joint welded assembly : -104 °C

**ANSI Flange MDMT including Temperature reduction per UCS-66.1:**

Unadjusted MDMT of ASME B16.5/47 flanges per UCS-66(c) -18 °C  
 Flange MDMT with Temp reduction per UCS-66(b)(1)(-b) -32 °C

Where the Stress Reduction Ratio per UCS-66(b)(1)(-b) is :

Design Pressure/Ambient Rating =  $1.45 / 1.96 = 0.740$

Weld Size Calculations, Description: Noz N1

Intermediate Calc. for nozzle/shell Welds Tmin 5.1800 mm

**Results Per UW-16.1:**

	Required Thickness	Actual Thickness
Nozzle Weld	$3.6260 = 0.7 * t_{min}$	$4.2420 = 0.7 * W_o$ mm

Skipping the nozzle attachment weld strength calculations.  
 Per UW-15(b)(2) the nozzles exempted by UG-36(c)(3)(a)  
 (small nozzles) do not require a weld strength check.

**Maximum Allowable Pressure for this Nozzle at this Location:**

Converged Max. Allow. Pressure in Operating case 4.83 N/mm<sup>2</sup>

Note: The MAWP of this junction was limited by the parent Shell/Head.

The Drop for this Nozzle is : 2.4222 mm

The Cut Length for this Nozzle is, Drop + Ho + H + T : 82.6022 mm

**PV Elite is a trademark of Hexagon AB, 2021, All rights reserved.**

# Report – Instrument air outlet\_LI4732

## **PV-Elite Calculation Summary**

Client: Airpack Nederland BV.  
Client location: Zierikzee  
Ref number client: 17811-OO-0702(KP)

### **PPV Engineering**

Author: H.Hoezen  
- Telephone: +31 (0)594 581010  
- E-mail: h.hoezen@ppv-engineering.nl

April 19, 2022  
Order number: P22-115-01  
Document number: 22-11501-C06  
Revision: 0

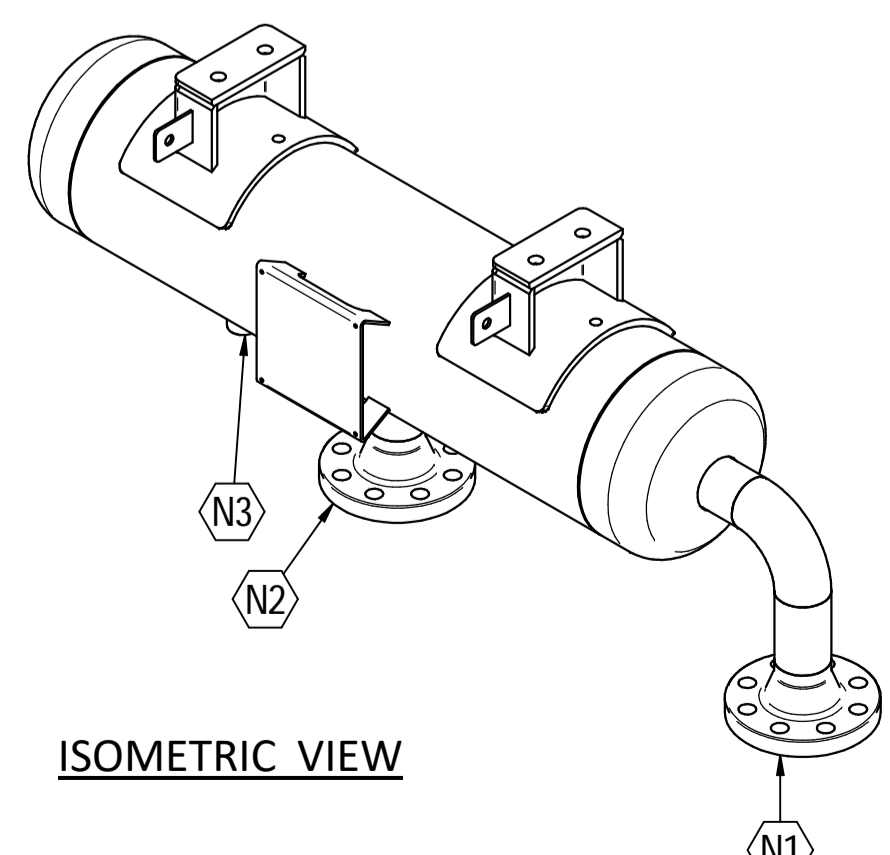
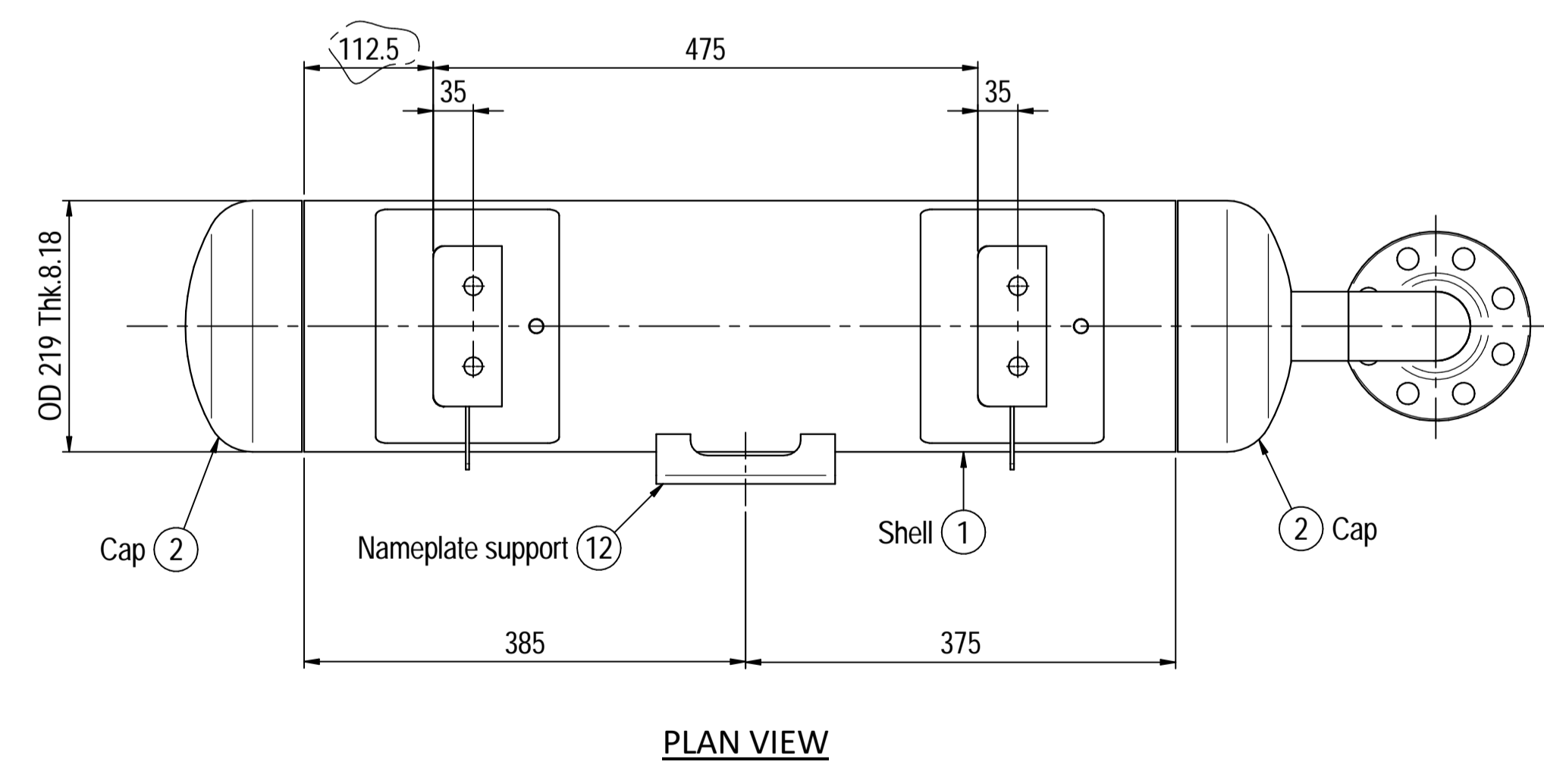
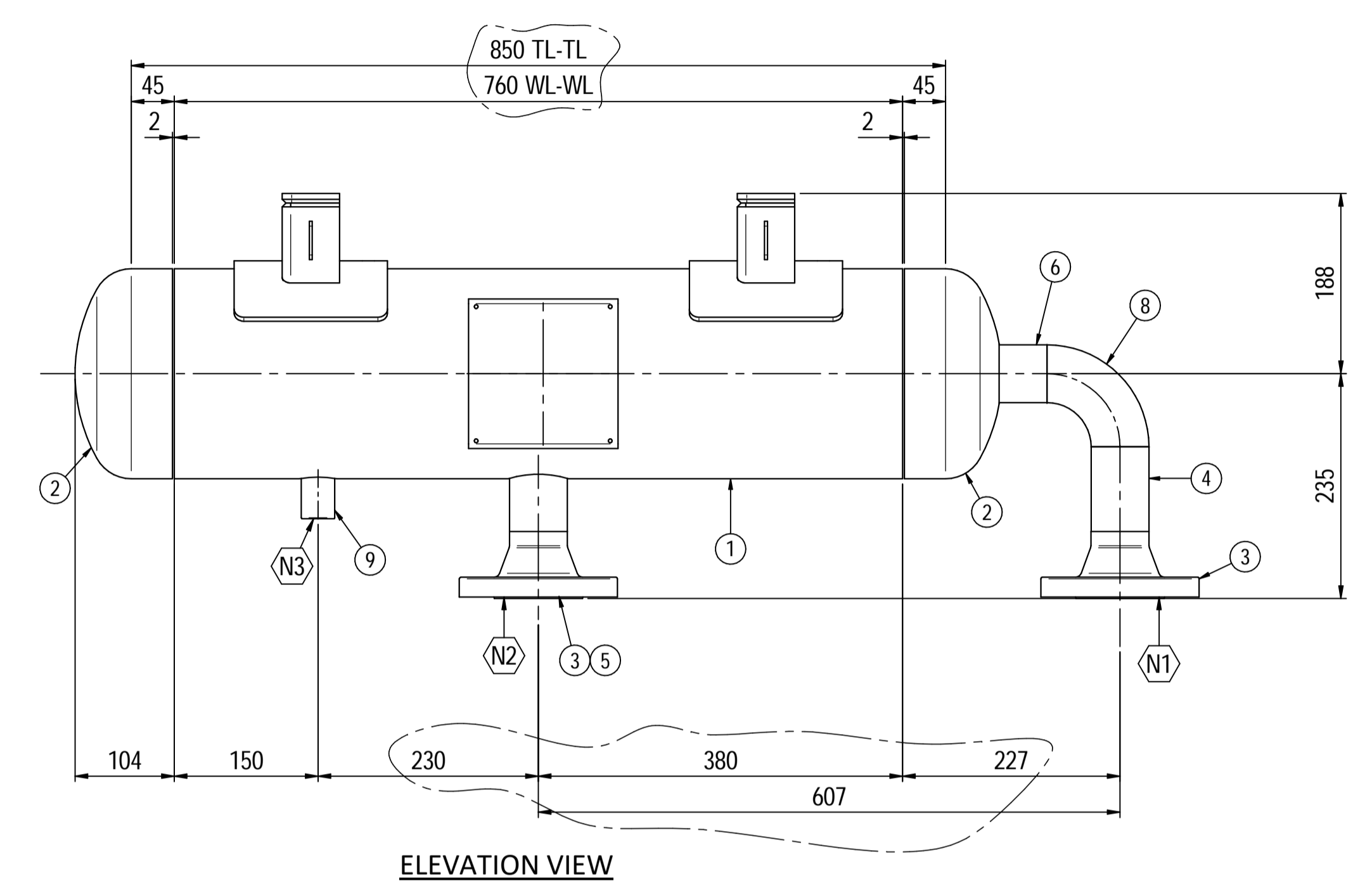
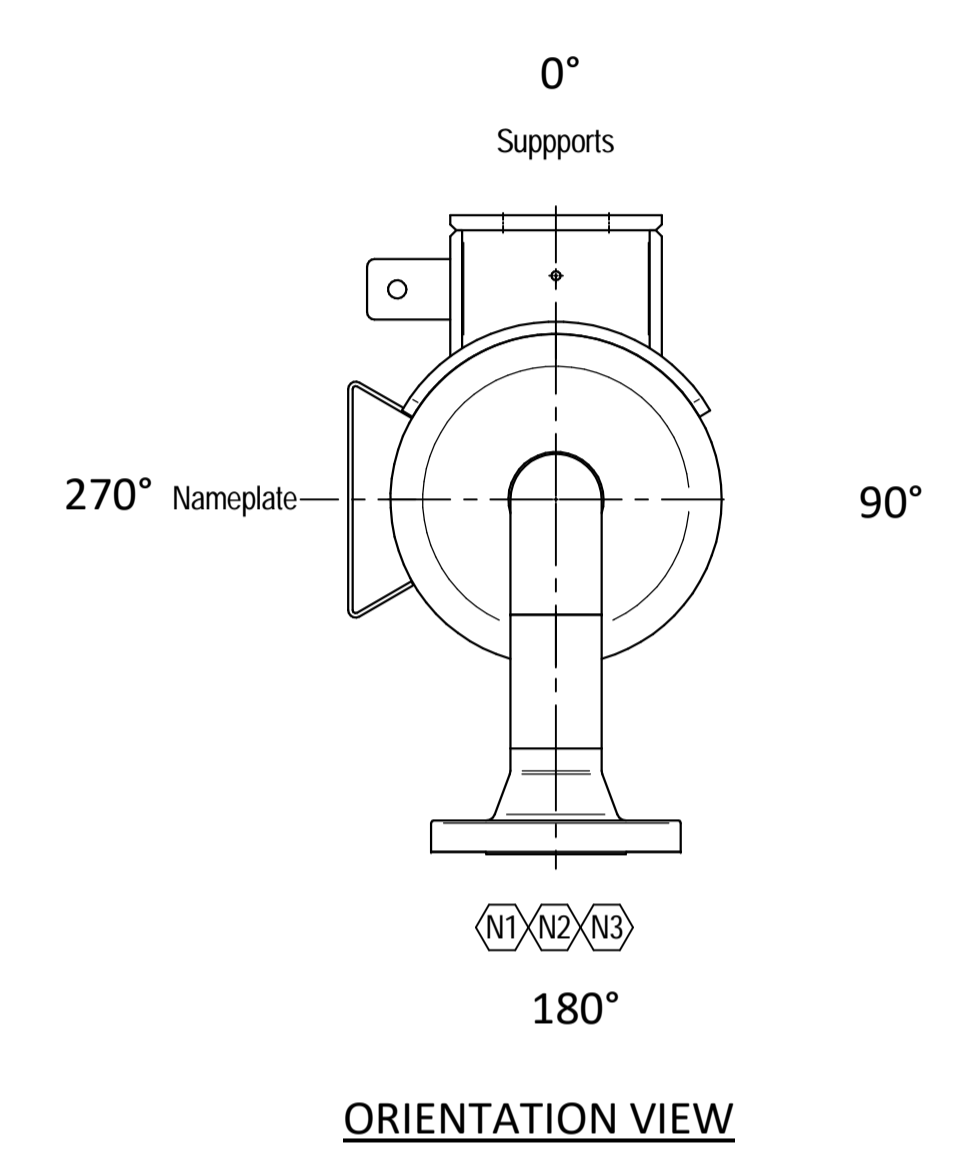
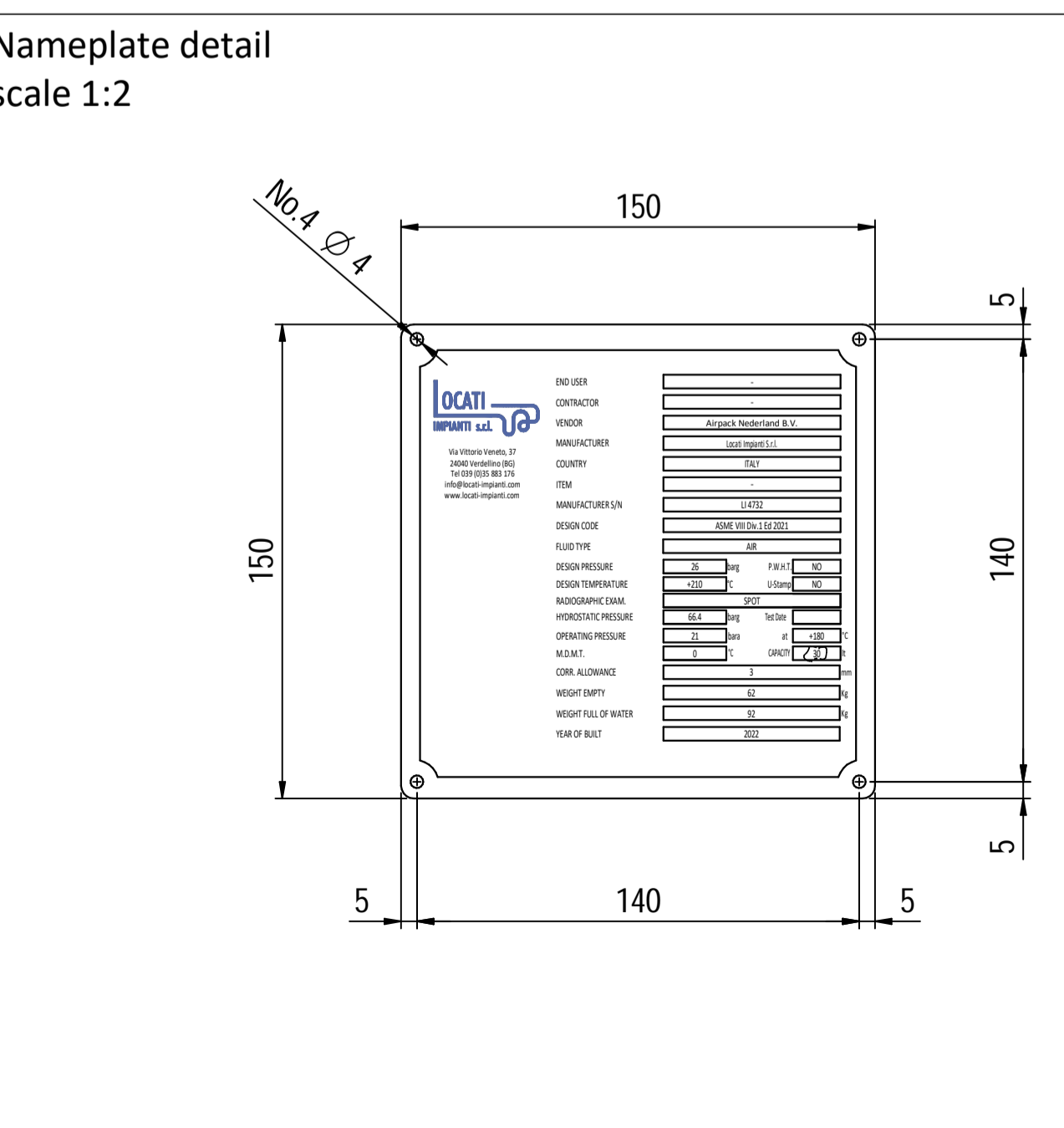
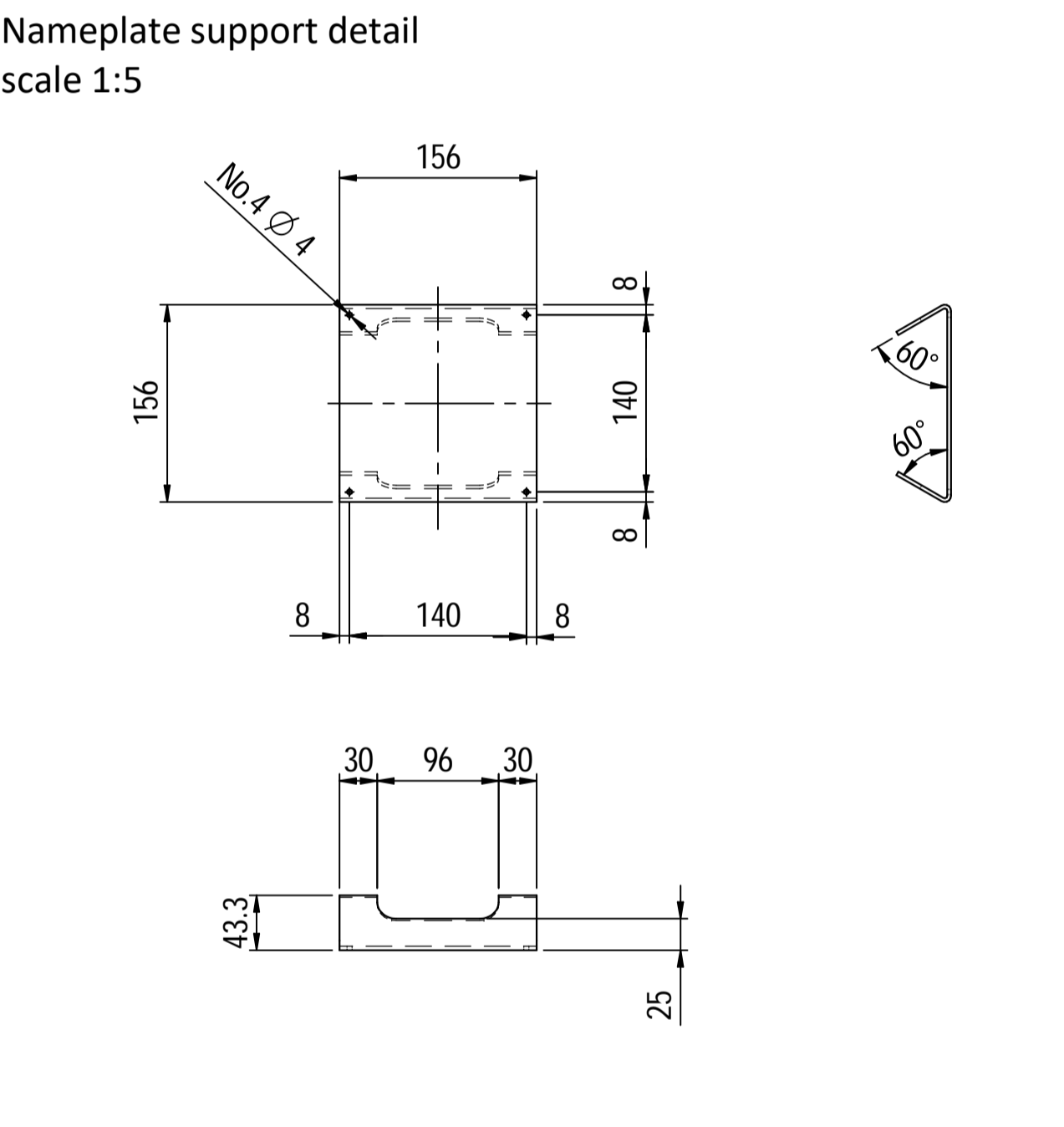
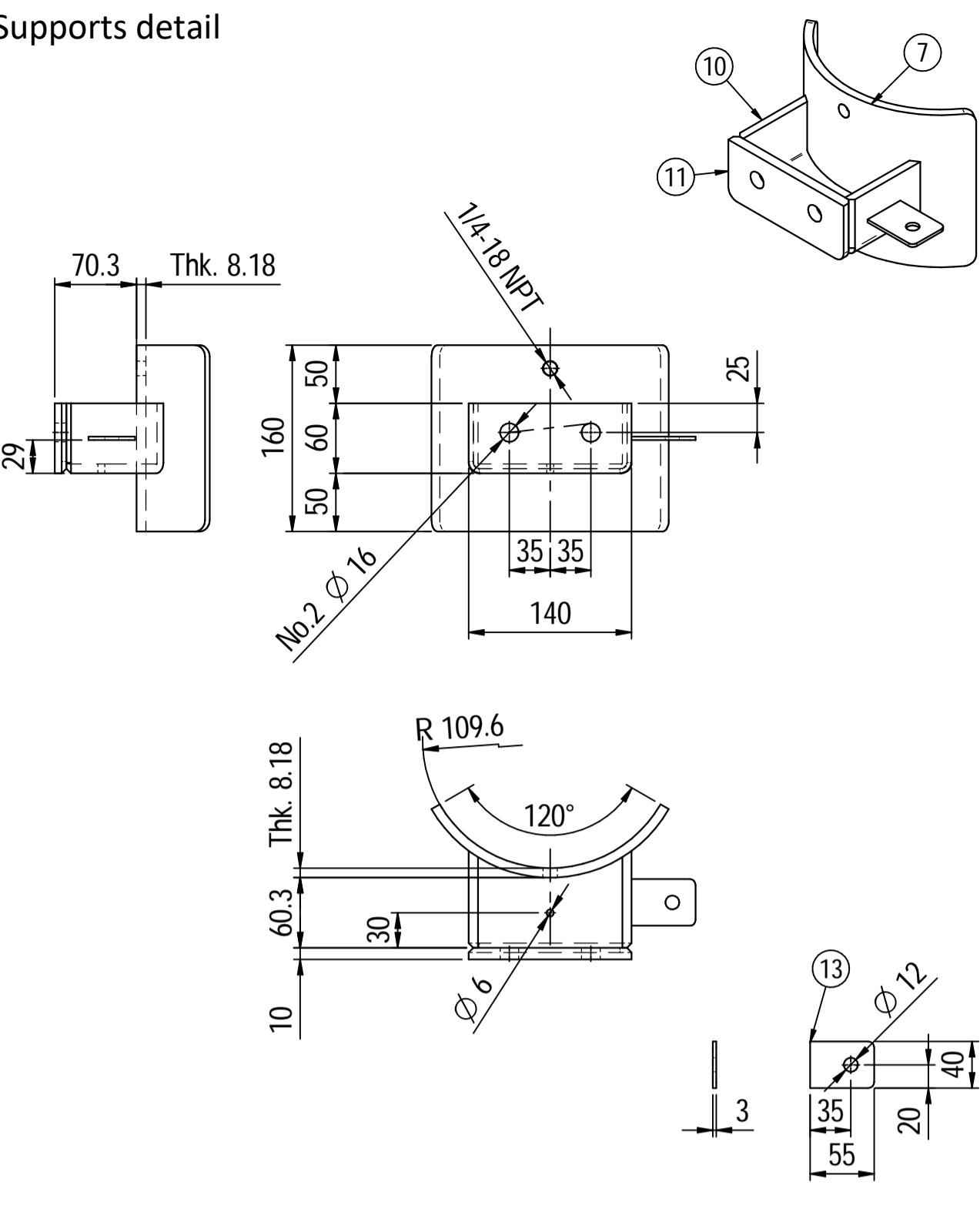

Material List					
Pos.	Q.ty	Description	Mat.	Cert.	
1	1	Shell by seamless pipe 8" Sch.40(L=760 )	SA106 Gr.B	3.1	
2	2	Cap 8" Sch40	A234 WPB	3.1	
3	2	Flange 2" WN #300 RF Sch.160	A105	3.1	
4	1	Seamless pipe 2" Sch160 L=88.5	A106 GrB	3.1	
5	1	Seamless pipe 2" Sch160 L=74	A106 GrB	3.1	
6	1	Seamless pipe 2" Sch160 L=63	A106 GrB	3.1	
7	2	Pad by pipe 8" Sch.40	A106 Gr.B	3.1	
8	1	Seamless elbow 2" 90° LR Sch.160	SA 234 WPB	3.1	
9	1	Coupling 1/2" NPT #6000	A105	3.1	
10	2	Plate 83x231 Thk.8	A516 70	3.1	
11	2	Plate 60x140 Thk.10	A516 70	3.1	
12	1	Nameplate support 156x241 Thk.3mm	A516 70	3.1	
13	2	Earthing Plate 55 x 40 Thk.3	A240 TP316L	3.1	

Note:  
 1) Governing measurement S.I. unless otherwise specified;  
 2) Flange bolt holes have to be straddled from main vessel center line in plan & vertical & horizontal centreline in elevation;  
 3) Material: certification 3.1 EN 10204;  
 4) All internal edge shall be rounded off;  
 5) Nozzle fittings in accordance with ASME B16.5: 2013;  
 6) Flange fittings in accordance with ASME B16.9: 2012;  
 7) The flange dimensions are in accordance with ASME B16.5: 2013;  
 8) All fillet welds not detailed on "WELDING MAP" or drawing shall have the weld; throated equal to 0,7 times the minimum thickness to be welded;  
 9) All welds are continuous except where indicate;  
 10) See document C220006CLC008 for vessel calculation.

ITEM	QTY	SERVICE	SIZE	O.D.	THK	RATING	TYPE	FACE	O.D.	THK.	Tc
N3	1	DRAIN	1/2"	38.1	8.38	#6000	-	NPT-F	-	-	8.5 ± 10
N2	1	AIR OUTLET	2"	60.3	8.74	#300	WN	RF	-	-	8.5 ± 10
N1	1	AIR INLET	2"	60.3	8.74	#300	WN	RF	-	-	8.5 ± 10

DATI DI PROGETTO / Design data			
FLUIDO	Air	COLLAUDO	Lloyd register
STATO FISICO DEL FLUIDO	Gas	TEST	NATIONAL BOARD REGISTRATION
CODICE DI CALCOLO	ASME VIII Div. 1 Ed.2021	CANADIAN REGISTER NUMBER	NO
PRESSIONE DI ESERCIZIO	21 bara	SERVIZIO LETALE	NO
PRESSIONE DI PROGETTO	26 barg	X-RAY	RT examination
PRESSIONE ESTERNA	NO	LICUIDI PENETRANTI	NO
PRESSIONE DI PROVA IDRAULICA	66.4 barg	ULTRASUONI	NO
TEMPERATURA DI ESERCIZIO	+180°C	CONTROLLO MAGNETOSCOPICO	NO
TEMPERATURA DI PROGETTO	+210 °C	WELD TESTS	NO
SOVRAME TALLO DI CORROSIONE	3 mm	PROCEDIMENTO DI SALDATURA	See doc: C220006WBK013
CAPACITA'	30 l	TIPO DI FONDO	CAP
EFFICIENZA GIUNTI	0.85	FORMAZIONE FONDO	HOT
MAWP @ Design Temperature	38.66 barg @ +210°C	PESO A VUOTO	63 kg
MAWP(EXT)	NO	PESO IN ESERCIZIO	63 kg
MDMT @ MAWP	0 °C @ 38.66 barg	PESO PIENO D'ACQUA	92 kg
TRATTAMENTO TERMICO	NO	DATI DEL VENTO	-
IMPACT TEST	NO	DATI SISMICI	-

Rev.	Descrizione / Description	Disegnato/Draw	Controllato/Checked	Approvato/Approved	Data/Date
02	Modified as per Customer comments	CM	MV	GL	02/04/2022
01	Modified earthing lug	CM	MV	GL	25/03/2022
00	FIRST ISSUE	CM	MV	GL	16/03/2022

## DESIGN CALCULATION

*In Accordance with ASME Section VIII Division 1*

ASME Code Version : 2019

Analysis Performed by : PPV-Engineering B.V.

Job File : P:\2\_ENGINEERING\PROJ-2022\P22-115-AIRZI\01\_PV E

Date of Analysis : Apr 13,2022 10:37am

PV Elite 23 SP2, October 2021

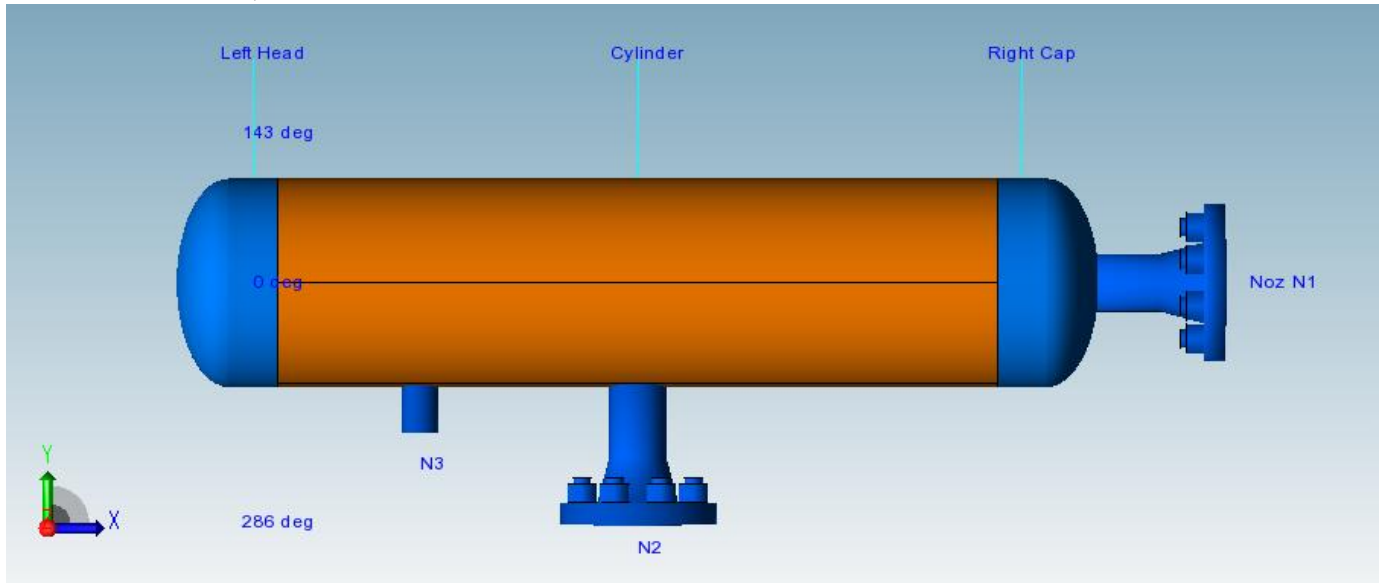

# Table of Contents

Cover Sheet.....	2
Vessel Design Summary:.....	3
Nozzle Summary: .....	5
Nozzle Schedule:.....	6
Bill of Material:.....	7
Input Echo:.....	8
Internal Pressure Calculations: .....	12
Element and Detail Weights:.....	16
Nozzle Flange MAWP:.....	18
Nozzle Calcs.: N2 .....	19
Nozzle Calcs.: N3 .....	22
Nozzle Calcs.: Noz N1.....	25

**Vessel Design Summary:**

**ASME Code, Section VIII Division 1, 2019**

Diameter Spec : 219.100 mm OD	
Vessel Design Length, Tangent to Tangent	862.63 mm
Specified Datum Line Distance	51.31 mm
Internal Design Temperature	210 °C
Internal Design Pressure	2.600 N/mm <sup>2</sup>
External Design Temperature	210 °C
Maximum Allowable Working Pressure	3.864 N/mm <sup>2</sup>
Shop Test Pressure	6.640 N/mm <sup>2</sup>
Required Minimum Design Metal Temperature	-28.9 °C
Warmest Computed Minimum Design Metal Temperature	-47.0 °C
Wind Design Code	No Wind Loads
Earthquake Design Code	No Seismic

**Materials of Construction:**

Component Type	Material	Class	Thickness	UNS #	Normal ized	Impact Tested
Shell	SA-106 B	...	...	K03006	No	No
Head	SA-234 WPB	...	...	K03006	No	No
Nozzle	SA-106 B	...	...	K03006	No	No
Nozzle Flg	SA-105	...	...	K03504	No	No

Normalized is determined based on the UCS-66 material curve selection and Figure UCS-66.  
 Impact Tested is based on material selection and material data properties.

**Element Pressures and MAWP (N/mm<sup>2</sup> & mm):**

Element Description or Type	Design Pressure + Stat. head	Ext. Press.	Element M.A.W.P	Total Corrosion Allowance	Str. Flg. Gov.	In Creep Range
Left Head	2.600	0.00	4.830	3.0000	Yes	No
Cylinder	2.600	0.00	3.864	3.0000	N/A	No
Right Cap	2.600	0.00	4.830	3.0000	Yes	No

**Element Types and Properties:**

Element Type	"To" Elev mm	Element Length mm	Nominal Thickness mm	Finished Thickness mm	Reqd Thk Internal mm	Reqd Thk External mm	Long Eff	Circ Eff
Ellipse	0.0	51.3	8.2	8.2	5.7	4.5	0.85	0.85
Cylinder	760.0	760.0	8.2	7.2	5.8	...	0.85	0.85
Ellipse	811.3	51.3	8.2	8.2	5.7	4.5	0.85	0.85

PV Elite 23 SP2 Licensee: PPV-Engineering B.V.

FileName : Instrument air outlet\_LI4732 -----

Vessel Design Summary: Step: 15 10:37am Apr 13,2022

**Weights:**

Fabricated - Bare W/O Removable Internals	54.1	kgm
Shop Test - Fabricated + Water ( Full )	84.6	kgm
Shipping - Fab. + Rem. Intls.+ Shipping App.	54.1	kgm
Erected - Fab. + Rem. Intls.+ Insul. (etc)	54.1	kgm
Empty - Fab. + Intls. + Details + Wghts.	54.1	kgm
Operating - Empty + Operating Liquid (No CA)	54.1	kgm
Field Test - Empty Weight + Water (Full)	84.6	kgm

**PV Elite is a trademark of Hexagon AB, 2021, All rights reserved.**

FileName : Instrument air outlet\_LI4732 -----

Nozzle Summary: Step: 13 10:37am Apr 13,2022

**Nozzle Calculation Summary:**

Description	MAWP N/mm <sup>2</sup>	Ext	MAPNC N/mm <sup>2</sup>	UG-45	[tr] mm	Weld Path	Areas or Stresses
N2	3.864	...	...	OK	5.33	OK	No Calc[*]
N3	3.864	...	...	OK	5.33	OK	No Calc[*]
Noz N1	4.83	...	...	OK	5.22	OK	No Calc[*]

**Nozzle MAWP Summary:**

Minimum MAWP Nozzles : 3.864 Nozzle : N3  
 Minimum MAWP Shells/Flanges : 3.864 Element : Cylinder  
 Minimum MAPnc Shells/Flanges : 5.11 Element : Cylinder  
 -----  
 Computed Vessel M.A.W.P. : 3.864 N/mm<sup>2</sup>

[\*] - This was a small opening and the areas were not computed.

Note: MAWPs (Internal Case) shown above are at the High Point.

**Check the Spatial Relationship between the Nozzles:**

From Node	Nozzle Description	X Coordinate mm	Layout Angle deg	Dia. Limit mm
20	N2	431.315	270.000	97.700
20	N3	201.315	270.000	54.672
30	Noz N1	0.000	0.000	97.700

**The nozzle spacing is computed by the following:**

= Sqrt( ll<sup>2</sup> + lc<sup>2</sup> ) where

ll - Arc length along the inside vessel surface in the long. direction.

lc - Arc length along the inside vessel surface in the circ. direction

If any interferences/violations are found, they will be noted below.

No interference violations have been detected!

PV Elite is a trademark of Hexagon AB, 2021, All rights reserved.

FileName : Instrument air outlet\_LI4732 -----

Nozzle Schedule: Step: 12 10:37am Apr 13,2022

**Nozzle Schedule:**

Description	Nominal or Actual Size	Schd or Type	Flg Type	Nozzle O/Dia mm	Wall Thk mm	Reinforcing Diameter	Pad Thk mm	Cut Length mm	Flg Class
N3	38 mm	Actual	Non	38.1	8.4	...	...	5	...
N2	50 mm	160	WN	60.3	8.7	...	...	8	300
Noz N1	50 mm	160	WN	60.3	8.7	...	...	7	300

*General Notes for the above table:*

The Cut Length is the Outside Projection + Inside Projection + Drop + In Plane Shell Thickness. This value does not include weld gaps, nor does it account for shrinkage.

In the case of Oblique Nozzles, the Outside Diameter must be increased. The Re-Pad WIDTH around the nozzle is calculated as follows:  
 Width of Pad = (Pad Outside Dia. (per above) - Nozzle Outside Dia.)/2

For hub nozzles, the thickness and diameter shown are those of the smaller and thinner section.

**Nozzle Material and Weld Fillet Leg Size Details (mm):**

Description	Material	Shl Grve Weld	Noz Shl/Pad Weld	Pad OD Weld	Pad Grve Weld	Inside Weld
N3	SA-106 B	8.340	6.000	...	...	...
N2	SA-106 B	8.340	6.000	...	...	...
Noz N1	SA-106 B	7.160	6.000	...	...	...

Note: The Outside projections below do not include the flange thickness.

**Nozzle Miscellaneous Data:**

Description	Elev/Distance From Datum mm	Layout Angle deg	Proj Outside mm	Proj Inside mm	Installed in Component
N3	150.000	270.0	47.62	0.00	Cylinder
N2	380.000	270.0	74.00	0.00	Cylinder
Noz N1	...	0.0	63.00	0.00	Right Cap

PV Elite is a trademark of Hexagon AB, 2021, All rights reserved.

**Bill of Materials:**

QTY	DESCRIPTION	MATERIAL
2	ELLIPTICAL HEAD: 2.0 X 1, 8.2mm THK X 202.7mm ID X 51.3mm	SA-234 WPB
2	CYLINDRICAL SEGMENT 8.2mm THK X 255.5mm X 760.0mm	SA-106 B
1	CYLINDRICAL SEGMENT 8.2mm THK X 132.2mm X 760.0mm	SA-106 B
1	NAMEPLATE	...

PV Elite is a trademark of Hexagon AB, 2021, All rights reserved.

FileName : Instrument air outlet\_LI4732 -----

Input Echo: Step: 1 10:37am Apr 13,2022

**PV Elite Vessel Analysis Program: Input Data**

Design Internal Pressure (for Hydrotest)	2.6	N/mm <sup>2</sup>
Design Internal Temperature	210.0	°C
Projection of Nozzle from Vessel Top	0	mm
Projection of Nozzle from Vessel Bottom	0	mm
Minimum Design Metal Temperature	-28.9	°C
Type of Construction	Welded	
Special Service	None	
Degree of Radiography	RT-3	
Use Higher Longitudinal Stresses (Flag)	Y	
Select t for Internal Pressure (Flag)	N	
Select t for External Pressure (Flag)	N	
Select t for Axial Stress (Flag)	N	
Select Location for Stiff. Rings (Flag)	N	
Consider Vortex Shedding	N	
Perform a Corroded Hydrotest	N	

**Shop Pressure Test:**

Type of Pressure Test	User Entered Pressure
Pressure Test Position	Horizontal

Load Case 1	NP+EW+WI+FW+BW
Load Case 2	NP+EW+EE+FS+BS
Load Case 3	NP+OW+WI+FW+BW
Load Case 4	NP+OW+EQ+FS+BS
Load Case 5	NP+HW+HI
Load Case 6	NP+HW+HE
Load Case 7	IP+OW+WI+FW+BW
Load Case 8	IP+OW+EQ+FS+BS
Load Case 9	EP+OW+WI+FW+BW
Load Case 10	EP+OW+EQ+FS+BS
Load Case 11	HP+HW+HI
Load Case 12	HP+HW+HE
Load Case 13	IP+WE+EW
Load Case 14	IP+WF+CW
Load Case 15	IP+VO+OW
Load Case 16	IP+VE+EW
Load Case 17	NP+VO+OW
Load Case 18	FS+BS+IP+OW
Load Case 19	FS+BS+EP+OW

Wind Design Code No Wind Loads

Seismic Design Code No Seismic

Design Pressure + Static Head	Y
Consider MAP New and Cold in Noz. Design	N
Consider External Loads for Nozzle Des.	Y
Use ASME VIII-1 Appendix 1-9	N

Material Database Year Current w/Addenda or Code Year

**Configuration Directives:**

Do not use Nozzle MDMT Interpretation VIII-1 01-37	No
Use Table G instead of exact equation for "A"	Yes
Shell Head Joints are Tapered	Yes
Compute "K" in corroded condition	Yes
Use Code Case 2286	No
Use the MAWP to compute the MDMT	Yes
For thickness ratios <= 0.35, MDMT will be -155F (-104C)	Yes
For PWHT & P1 Materials the MDMT can be < -55F (-48C)	No

FileName : Instrument air outlet\_LI4732 -----

Input Echo: Step: 1 10:37am Apr 13,2022

Using Metric Material Databases, ASME II D No  
 Calculate B31.3 type stress for Nozzles with Loads Yes  
 Reduce the MDMT due to lower membrane stress Yes  
 Consider Longitudinal Stress in MDMT calcs. (Div. 1) Yes

**Complete Listing of Vessel Elements and Details:**

Element From Node 10  
 Element To Node 20  
 Element Type Elliptical  
 Description Left Head  
 Distance "FROM" to "TO" 51.315 mm  
 Element Outside Diameter 219.1 mm  
 Element Thickness 8.18 mm  
 Internal Corrosion Allowance 3 mm  
 Nominal Thickness 8.18 mm  
 External Corrosion Allowance 0 mm  
 Design Internal Pressure 2.6 N/mm<sup>2</sup>  
 Design Temperature Internal Pressure 210 °C  
 Design External Pressure 0 N/mm<sup>2</sup>  
 Design Temperature External Pressure 210 °C  
 Effective Diameter Multiplier 1.2  
 Material Name SA-234 WPB  
     Allowable Stress, Ambient 117.9 N/mm<sup>2</sup>  
     Allowable Stress, Operating 117.9 N/mm<sup>2</sup>  
     Allowable Stress, Hydrotest 153.27 N/mm<sup>2</sup>  
     Material Density 7750.4 kg/m<sup>3</sup>  
     P Number Thickness 30.988 mm  
     Yield Stress, Operating 205.19 N/mm<sup>2</sup>  
     UCS-66 Chart Curve Designation B  
     External Pressure Chart Name CS-2  
     UNS Number K03006  
     Product Form Smls. & wld. fittings  
 Efficiency, Longitudinal Seam 0.85  
 Efficiency, Circumferential Seam 0.85  
 Elliptical Head Factor 2.0  
 Weld is pre-Heated No

-----  
 Element From Node 20  
 Element To Node 30  
 Element Type Cylinder  
 Description Cylinder  
 Distance "FROM" to "TO" 760 mm  
 Element Outside Diameter 219.1 mm  
 Element Thickness 7.16 mm  
 Internal Corrosion Allowance 3 mm  
 Nominal Thickness 8.18 mm  
 External Corrosion Allowance 0 mm  
 Design Internal Pressure 2.6 N/mm<sup>2</sup>  
 Design Temperature Internal Pressure 210 °C  
 Design External Pressure 0 N/mm<sup>2</sup>  
 Design Temperature External Pressure 210 °C  
 Effective Diameter Multiplier 1.2  
 Material Name SA-106 B  
     Allowable Stress, Ambient 117.9 N/mm<sup>2</sup>  
     Allowable Stress, Operating 117.9 N/mm<sup>2</sup>  
     Allowable Stress, Hydrotest 153.27 N/mm<sup>2</sup>  
     Material Density 7750.4 kg/m<sup>3</sup>  
     P Number Thickness 30.988 mm  
     Yield Stress, Operating 205.19 N/mm<sup>2</sup>  
     UCS-66 Chart Curve Designation B  
     External Pressure Chart Name CS-2

FileName : Instrument air outlet\_LI4732 -----

Input Echo: Step: 1 10:37am Apr 13,2022

UNS Number	K03006
Product Form	Smls. pipe
Efficiency, Longitudinal Seam	0.85
Efficiency, Circumferential Seam	0.85
Weld is pre-Heated	No

Element From Node	20
Detail Type	Nozzle
Detail ID	N2
Dist. from "FROM" Node / Offset dist	380 mm
Nozzle Diameter	50 mm
Nozzle Schedule	160
Nozzle Class	300
Layout Angle	270.0
Blind Flange (Y/N)	N
Weight of Nozzle ( Used if > 0 )	0 N
Grade of Attached Flange	GR 1.1
Nozzle Matl	SA-106 B

Element From Node	20
Detail Type	Nozzle
Detail ID	N3
Dist. from "FROM" Node / Offset dist	150 mm
Nozzle Diameter	38.1 mm
Nozzle Schedule	None
Nozzle Class	None
Layout Angle	270.0
Blind Flange (Y/N)	N
Weight of Nozzle ( Used if > 0 )	0 N
Grade of Attached Flange	None
Nozzle Matl	SA-106 B

-----

Element From Node	30
Element To Node	40
Element Type	Elliptical
Description	Right Cap
Distance "FROM" to "TO"	51.315 mm
Element Outside Diameter	219.1 mm
Element Thickness	8.18 mm
Internal Corrosion Allowance	3 mm
Nominal Thickness	8.18 mm
External Corrosion Allowance	0 mm
Design Internal Pressure	2.6 N/mm <sup>2</sup>
Design Temperature Internal Pressure	210 °C
Design External Pressure	0 N/mm <sup>2</sup>
Design Temperature External Pressure	210 °C
Effective Diameter Multiplier	1.2
Material Name	SA-234 WPB
Allowable Stress, Ambient	117.9 N/mm <sup>2</sup>
Allowable Stress, Operating	117.9 N/mm <sup>2</sup>
Allowable Stress, Hydrotest	153.27 N/mm <sup>2</sup>
Material Density	7750.4 kg/m <sup>3</sup>
P Number Thickness	30.988 mm
Yield Stress, Operating	205.19 N/mm <sup>2</sup>
UCS-66 Chart Curve Designation	B
External Pressure Chart Name	CS-2
UNS Number	K03006
Product Form	Smls. & wld. fittings
Efficiency, Longitudinal Seam	0.85
Efficiency, Circumferential Seam	0.85
Elliptical Head Factor	2.0
Weld is pre-Heated	No

FileName : Instrument air outlet\_LI4732 -----

Input Echo: Step: 1 10:37am Apr 13,2022

Element From Node	30
Detail Type	Nozzle
Detail ID	Noz N1
Dist. from "FROM" Node / Offset dist	0 mm
Nozzle Diameter	50 mm
Nozzle Schedule	160
Nozzle Class	300
Layout Angle	0.0
Blind Flange (Y/N)	N
Weight of Nozzle ( Used if > 0 )	0 N
Grade of Attached Flange	GR 1.1
Nozzle Matl	SA-106 B

**PV Elite is a trademark of Hexagon AB, 2021, All rights reserved.**

**Internal Pressure Results Summary:**

**Element Thickness, Pressure, Diameter and Allowable Stress :**

From	To	Int. Press + Liq. Hd N/mm <sup>2</sup>	Nominal Thickness mm	Total Corr Allowance mm	Element Diameter mm	Allowable Stress (SE) N/mm <sup>2</sup>
Left Head		2.6	8.18	3	219.1	100.22
Cylinder		2.6	8.18	3	219.1	100.22
Right Cap		2.6	8.18	3	219.1	100.22

**Element Required Thickness and MAWP :**

From	To	Design Pressure N/mm <sup>2</sup>	M.A.W.P. Corroded N/mm <sup>2</sup>	M.A.P. New & Cold N/mm <sup>2</sup>	Minimum Thickness mm	Required Thickness mm
Left Head		2.6	4.83	8.022	8.18	5.6778
Cylinder		2.6	3.864	6.726	7.16	5.81299
Right Cap		2.6	4.83	8.022	8.18	5.6778
Minimum			3.864	5.11		

Note : The M.A.P.(NC) is Governed by a Flange !

MAWP: 3.864 N/mm<sup>2</sup>, limited by: Cylinder.

Elements Suitable for Design Internal Pressure.

**Internal Pressure Calculation Results:**

**ASME Code, Section VIII Division 1, 2019**

**Elliptical Head From 10 To 20 SA-234 WPB , UCS-66 Crv. B at 210 °C**

Left Head

Material UNS Number: K03006

Required Thickness due to Internal Pressure [tr]:

$$= (P \cdot Do \cdot K_{cor}) / (2 \cdot S \cdot E + 2 \cdot P \cdot (K_{cor} - 0.1)) \text{ per Appendix 1-4 (c)}$$

$$= (2.6 \cdot 219.1 \cdot 0.963) / (2 \cdot 117.9 \cdot 0.85 + 2 \cdot 2.6 \cdot (0.963 - 0.1))$$

$$= 2.6778 + 3.0000 = 5.6778 \text{ mm}$$

Max. Allowable Working Pressure at given Thickness, corroded [MAWP]:

$$= (2 \cdot S \cdot E \cdot t) / (K_{cor} \cdot Do - 2 \cdot t \cdot (K_{cor} - 0.1)) \text{ per Appendix 1-4 (c)}$$

$$= (2 \cdot 117.9 \cdot 0.85 \cdot 5.18) / (0.963 \cdot 219.1 - 2 \cdot 5.18 \cdot (0.963 - 0.1))$$

$$= 5.137 \text{ N/mm}^2$$

Maximum Allowable Pressure, New and Cold [MAPNC]:

$$= (2 \cdot S \cdot E \cdot t) / (K \cdot Do - 2 \cdot t \cdot (K - 0.1)) \text{ per Appendix 1-4 (c)}$$

$$= (2 \cdot 117.9 \cdot 0.85 \cdot 8.18) / (1 \cdot 219.1 - 2 \cdot 8.18 \cdot (1 - 0.1))$$

$$= 8.022 \text{ N/mm}^2$$

Actual stress at given pressure and thickness, corroded [Sact]:

$$= (P \cdot (K_{cor} \cdot Do - 2 \cdot t \cdot (K_{cor} - 0.1))) / (2 \cdot E \cdot t)$$

$$= (2.6 \cdot (0.963 \cdot 219.1 - 2 \cdot 5.18 \cdot (0.963 - 0.1))) / (2 \cdot 0.85 \cdot 5.18)$$

$$= 59.673 \text{ N/mm}^2$$

Straight Flange Required Thickness:

$$= (P \cdot Ro) / (S \cdot E + 0.4 \cdot P) + ca \text{ per Appendix 1-1 (a) (1)}$$

$$= (2.6 \cdot 109.5) / (117.9 \cdot 0.85 + 0.4 \cdot 2.6) + 3$$

PV Elite 23 SP2 Licensee: PPV-Engineering B.V.

FileName : Instrument air outlet\_LI4732 -----

Internal Pressure Calculations: Step: 3 10:37am Apr 13,2022

$$= 5.813 \text{ mm}$$

Straight Flange Maximum Allowable Working Pressure:

$$= (S \cdot E \cdot t) / (R_o - 0.4 \cdot t) \text{ per Appendix 1-1 (a) (1)}$$

$$= (117.9 \cdot 0.85 \cdot 5.18) / (109.5 - 0.4 \cdot 5.18)$$

$$= 4.83 \text{ N/mm}^2$$

Factor K, corroded condition [Kcor]:

$$= (2 + (\text{Inside Diameter} / (2 \cdot \text{Inside Head Depth}))^2) / 6$$

$$= (2 + (208.7 / (2 \cdot 53.68))^2) / 6$$

$$= 0.963266$$

**MDMT Calculations in the Knuckle Portion:**

Govrn. thk, tg = 8.18, tr = 3.938, c = 3 mm, E\* = 0.85

Thickness Ratio = tr \* (E\*) / (tg - c) = 0.646, Temp. Reduction = 20 °C

Min Metal Temp. w/o impact per UCS-66, Curve B -29 °C  
 Min Metal Temp. at Required thickness (UCS 66.1) -48 °C

**MDMT Calculations in the Head Straight Flange:**

Govrn. thk, tg = 8.18, tr = 4.16, c = 3 mm, E\* = 0.85

Thickness Ratio = tr \* (E\*) / (tg - c) = 0.683, Temp. Reduction = 18 °C

Min Metal Temp. w/o impact per UCS-66, Curve B -29 °C  
 Min Metal Temp. at Required thickness (UCS 66.1) -47 °C

**Cylindrical Shell From 20 To 30 SA-106 B, UCS-66 Crv. B at 210 °C**

Cylinder

Longitudinal Joint: Seamless

Material UNS Number: K03006

Required Thickness due to Internal Pressure [tr]:

$$= (P \cdot R_o) / (S \cdot E + 0.4 \cdot P) \text{ per Appendix 1-1 (a) (1)}$$

$$= (2.6 \cdot 109.5) / (117.9 \cdot 0.85 + 0.4 \cdot 2.6)$$

$$= 2.8130 + 3.0000 = 5.8130 \text{ mm}$$

Max. Allowable Working Pressure at given Thickness, corroded [MAWP]:

$$= (S \cdot E \cdot t) / (R_o - 0.4 \cdot t) \text{ per Appendix 1-1 (a) (1)}$$

$$= (117.9 \cdot 0.85 \cdot 4.16) / (109.5 - 0.4 \cdot 4.16)$$

$$= 3.864 \text{ N/mm}^2$$

Maximum Allowable Pressure, New and Cold [MAPNC]:

$$= (S \cdot E \cdot t) / (R_o - 0.4 \cdot t) \text{ per Appendix 1-1 (a) (1)}$$

$$= (117.9 \cdot 0.85 \cdot 7.16) / (109.5 - 0.4 \cdot 7.16)$$

$$= 6.726 \text{ N/mm}^2$$

Actual stress at given pressure and thickness, corroded [Sact]:

$$= (P \cdot (R_o - 0.4 \cdot t)) / (E \cdot t)$$

$$= (2.6 \cdot ((109.5 - 0.4 \cdot 4.16)) / (0.85 \cdot 4.16))$$

$$= 79.328 \text{ N/mm}^2$$

**Minimum Design Metal Temperature Results:**

Govrn. thk, tg = 7.16, tr = 2.016, c = 3 mm, E\* = 0.85

Thickness Ratio = tr \* (E\*) / (tg - c) = 0.412, Temp. Reduction = 48 °C

Min Metal Temp. w/o impact per UCS-66, Curve B -29 °C  
 Min Metal Temp. at Required thickness (UCS 66.1) -48 °C

**Elliptical Head From 30 To 40 SA-234 WPB, UCS-66 Crv. B at 210 °C**

Right Cap  
 Material UNS Number: K03006

Required Thickness due to Internal Pressure [tr]:  
 $= (P \cdot Do \cdot K_{cor}) / (2 \cdot S \cdot E + 2 \cdot P \cdot (K_{cor} - 0.1))$  per Appendix 1-4 (c)  
 $= (2.6 \cdot 219.1 \cdot 0.963) / (2 \cdot 117.9 \cdot 0.85 + 2 \cdot 2.6 \cdot (0.963 - 0.1))$   
 $= 2.6778 + 3.0000 = 5.6778 \text{ mm}$

Max. Allowable Working Pressure at given Thickness, corroded [MAWP]:  
 $= (2 \cdot S \cdot E \cdot t) / (K_{cor} \cdot Do - 2 \cdot t \cdot (K_{cor} - 0.1))$  per Appendix 1-4 (c)  
 $= (2 \cdot 117.9 \cdot 0.85 \cdot 5.18) / (0.963 \cdot 219.1 - 2 \cdot 5.18 \cdot (0.963 - 0.1))$   
 $= 5.137 \text{ N/mm}^2$

Maximum Allowable Pressure, New and Cold [MAPNC]:  
 $= (2 \cdot S \cdot E \cdot t) / (K \cdot Do - 2 \cdot t \cdot (K - 0.1))$  per Appendix 1-4 (c)  
 $= (2 \cdot 117.9 \cdot 0.85 \cdot 8.18) / (1 \cdot 219.1 - 2 \cdot 8.18 \cdot (1 - 0.1))$   
 $= 8.022 \text{ N/mm}^2$

Actual stress at given pressure and thickness, corroded [Sact]:  
 $= (P \cdot (K_{cor} \cdot Do - 2 \cdot t \cdot (K_{cor} - 0.1))) / (2 \cdot E \cdot t)$   
 $= (2.6 \cdot (0.963 \cdot 219.1 - 2 \cdot 5.18 \cdot (0.963 - 0.1))) / (2 \cdot 0.85 \cdot 5.18)$   
 $= 59.673 \text{ N/mm}^2$

Straight Flange Required Thickness:  
 $= (P \cdot Ro) / (S \cdot E + 0.4 \cdot P) + ca$  per Appendix 1-1 (a) (1)  
 $= (2.6 \cdot 109.5) / (117.9 \cdot 0.85 + 0.4 \cdot 2.6) + 3$   
 $= 5.813 \text{ mm}$

Straight Flange Maximum Allowable Working Pressure:  
 $= (S \cdot E \cdot t) / (Ro - 0.4 \cdot t)$  per Appendix 1-1 (a) (1)  
 $= (117.9 \cdot 0.85 \cdot 5.18) / (109.5 - 0.4 \cdot 5.18)$   
 $= 4.83 \text{ N/mm}^2$

Factor K, corroded condition [Kcor]:  
 $= (2 + (\text{Inside Diameter} / (2 \cdot \text{Inside Head Depth}))^2) / 6$   
 $= (2 + (208.7 / (2 \cdot 53.68))^2) / 6$   
 $= 0.963266$

**MDMT Calculations in the Knuckle Portion:**

Govrn. thk, tg = 8.18, tr = 3.938, c = 3 mm, E\* = 0.85  
 Thickness Ratio = tr \* (E\*) / (tg - c) = 0.646, Temp. Reduction = 20 °C

Min Metal Temp. w/o impact per UCS-66, Curve B -29 °C  
 Min Metal Temp. at Required thickness (UCS 66.1) -48 °C

**MDMT Calculations in the Head Straight Flange:**

Govrn. thk, tg = 8.18, tr = 4.16, c = 3 mm, E\* = 0.85  
 Thickness Ratio = tr \* (E\*) / (tg - c) = 0.683, Temp. Reduction = 18 °C

Min Metal Temp. w/o impact per UCS-66, Curve B -29 °C  
 Min Metal Temp. at Required thickness (UCS 66.1) -47 °C

Note: Heads and Shells Exempted to -20F (-29C) by paragraph UG-20F

**Hydrostatic Test Pressure Results:**

Pressure per UG99b	= 1.30 * M.A.W.P. * Sa/S	5.023	N/mm <sup>2</sup>
Pressure per UG99b[35]	= 1.30 * Design Pres * Sa/S	3.380	N/mm <sup>2</sup>
Pressure per UG99c	= 1.30 * M.A.P. - Head(Hyd)	6.643	N/mm <sup>2</sup>
Pressure per UG100	= 1.10 * M.A.W.P. * Sa/S	4.251	N/mm <sup>2</sup>

PV Elite 23 SP2 Licensee: PPV-Engineering B.V.

FileName : Instrument air outlet\_LI4732 -----

Internal Pressure Calculations: Step: 3 10:37am Apr 13,2022

Pressure per PED = max(1.43\*DP, 1.25\*DP\*ratio) 3.718 N/mm<sup>2</sup>  
 Pressure per App 27-4 = M.A.W.P. 3.864 N/mm<sup>2</sup>  
 User Defined Hydrostatic Test Pressure at High Point 6.640 N/mm<sup>2</sup>

#### Horizontal Test performed per: User Hydro Pressure

*Please note that Nozzle, Shell, Head, Flange, etc MAWPs are all considered when determining the hydrotest pressure for those test types that are based on the MAWP of the vessel.*

#### Stresses on Elements due to Test Pressure (N/mm<sup>2</sup>):

From To	Stress	Allowable	Ratio	Pressure
Left Head	97.6	153.3	0.637	6.64
Cylinder	116.4	153.3	0.760	6.64
Right Cap	97.6	153.3	0.637	6.64

#### Stress ratios for Nozzle and Pad Materials (N/mm<sup>2</sup>):

Description	Pad/Nozzle	Ambient	Operating	Ratio
N2	Nozzle	117.90	117.90	1.000
N3	Nozzle	117.90	117.90	1.000
Noz N1	Nozzle	117.90	117.90	1.000
Minimum				1.000

#### Stress ratios for Pressurized Vessel Elements (N/mm<sup>2</sup>):

Description	Ambient	Operating	Ratio
Left Head	117.90	117.90	1.000
Cylinder	117.90	117.90	1.000
Right Cap	117.90	117.90	1.000
Minimum			1.000

#### Hoop Stress in Nozzle Wall during Pressure Test (N/mm<sup>2</sup>):

Description	Ambient	Operating	Ratio
N2	20.27	153.27	0.132
N3	12.44	153.27	0.081
Noz N1	20.27	153.27	0.132

Elements Suitable for Test Pressure.

PV Elite is a trademark of Hexagon AB, 2021, All rights reserved.

**Element and Detail Weights:**

From	To	Element Metal Wgt. kgm	Element ID Volume m <sup>3</sup>	Corroded Metal Wgt. kgm	Corroded ID Volume m <sup>3</sup>	Extra due Misc %
10	20	5.5314	0.0027479	3.50277	0.0029472	...
20	30	32.2363	0.025036	20.7012	0.026524	...
30	40	5.5314	0.0027479	3.50277	0.0029472	...
Total		43	0.03	27	0.03	0

**Weight of Details:**

From	Type	Weight of Detail kgm	X Offset, Dtl. Cent. mm	Y Offset, Dtl. Cent. mm	Z Offset, Dtl. Cent. mm	Description
20	Noz1	5.31107	380	-132.552	...	N2
20	Noz1	0.28886	150	-121.44	...	N3
30	Noz1	5.19036	102	...	...	Noz N1

**Total Weight of Each Detail Type:**

Nozzles	10.8
Sum of the Detail Weights	10.8 kgm

**Weight Summation Results: (kgm)**

	Fabricated	Shop Test	Shipping	Erected	Empty	Operating
Main Elements	43.3	43.3	43.3	43.3	43.3	43.3
Nozzles	10.8	10.8	10.8	10.8	10.8	10.8
Test Liquid	...	30.5	...	...	...	...
Totals	54.1	84.6	54.1	54.1	54.1	54.1

**Weight Summary:**

Fabricated Wt.	- Bare Weight without Removable Internals	54.1 kgm
Shop Test Wt.	- Fabricated Weight + Water ( Full )	84.6 kgm
Shipping Wt.	- Fab. Weight + removable Intls.+ Shipping App.	54.1 kgm
Erected Wt.	- Fab. Wt + or - loose items (trays,platforms etc.)	54.1 kgm
Ope. Wt. no Liq	- Fab. Weight + Internals. + Details + Weights	54.1 kgm
Operating Wt.	- Empty Weight + Operating Liq. Uncorroded	54.1 kgm
Oper. Wt. + CA	- Corr Wt. + Operating Liquid	38.5 kgm
Field Test Wt.	- Empty Weight + Water (Full)	84.6 kgm

**Note:**

The Corroded Weight and thickness are used in the Horizontal Vessel Analysis (Ope Case) and Earthquake Load Calculations.

**Outside Surface Areas of Elements:**

From	To	Surface Area cm <sup>2</sup>
10	20	873.578
20	30	5279.96
30	40	873.578

PV Elite 23 SP2 Licensee: PPV-Engineering B.V.  
FileName : Instrument air outlet\_LI4732 -----  
Element and Detail Weights: Step: 5 10:37am Apr 13,2022

-----  
Total 7027.118 cm<sup>2</sup>

**PV Elite is a trademark of Hexagon AB, 2021, All rights reserved.**

FileName : Instrument air outlet\_LI4732 -----

Nozzle Flange MAWP: Step: 6 10:37am Apr 13,2022

**Nozzle Flange MAWP Results: (N/mm<sup>2</sup> & °C)**

Nozzle Description	Flange Rating		Design Temp	Design Class	Grade/ Group	Equiv. Press	Max Pressure		
	Ope.	Ambient					UG-44(b)	50%	DNV
N2	4.34	5.11	210	300	GR 1.1	...	...	...	...
Noz N1	4.34	5.11	210	300	GR 1.1	...	...	...	...
Min Rating	4.342	5.110 N/mm <sup>2</sup> [for Core Elements]					0.000	0.000	0.000

Pressure Ratings are per ASME B16.5 2013 Metric Edition

PV Elite is a trademark of Hexagon AB, 2021, All rights reserved.

FileName : Instrument air outlet\_LI4732 -----

Nozzle Calcs.: N2

Noz1: 13 10:37am Apr 13,2022

**Input, Nozzle Desc: N2**

**From: 20**

Pressure for Reinforcement Calculations	P	2.6000	N/mm <sup>2</sup>
Temperature for Internal Pressure	Temp	210	°C
Parent Material		SA-106 B	
Parent Allowable Stress at Temperature	Sv	117.90	N/mm <sup>2</sup>
Parent Allowable Stress At Ambient	Sva	117.90	N/mm <sup>2</sup>
Inside Diameter of Cylindrical Shell	D	202.74	mm
Shell Finished (Minimum) Thickness	t	7.1600	mm
Shell Internal Corrosion Allowance	c	3.0000	mm
Shell External Corrosion Allowance	co	0.0000	mm
Distance from Bottom/Left Tangent		431.31	mm
User Entered Minimum Design Metal Temperature		-28.89	°C

**Type of Element Connected to the Parent : Nozzle**

Material		SA-106 B	
Material UNS Number		K03006	
Material Specification/Type		Smls. pipe	
Allowable Stress at Temperature	Sn	117.90	N/mm <sup>2</sup>
Allowable Stress At Ambient	Sna	117.90	N/mm <sup>2</sup>
Diameter Basis (for tr calc only)		Outside	
Layout Angle		270.00	deg
Diameter		50.0000	mm
Size and Thickness Basis		Nominal	
Nominal Thickness		160	
Flange Material		SA-105	
Flange Type		Weld Neck Flange	
Corrosion Allowance	can	3.0000	mm
Joint Efficiency of Shell Seam at Nozzle	E1	1.00	
Joint Efficiency of Nozzle Neck	En	1.00	
Outside Projection	ho	74.0000	mm
Weld leg size between Nozzle and Pad/Shell	Wo	6.0000	mm
Groove weld depth between Nozzle and Vessel	Wgnv	8.3400	mm
Flange Class		300	
Flange Grade		GR 1.1	

The Pressure Design option was Design Pressure + static head.

**Nozzle Sketch (may not represent actual weld type/configuration)**



**Abutting/Set-on Nozzle No Pad**

**Reinforcement CALCULATION, Description: N2**

ASME Code, Section VIII, Div. 1, 2019, UG-37 to UG-45

Actual Outside Diameter Used in Calculation 60.325 mm.  
 Actual Thickness Used in Calculation 8.738 mm

Nozzle input data check completed without errors.

Reqd thk per UG-37(a) of Cylindrical Shell, tr [Int. Press]

$$= P \cdot R / (S_v \cdot E - 0.6 \cdot P) \text{ per UG-27 (c) (1)}$$

$$= 2.6 \cdot 104.4 / (117.9 \cdot 1 - 0.6 \cdot 2.6)$$

$$= 2.3325 \text{ mm}$$

Reqd thk per UG-37(a) of Nozzle Wall, trn [Int. Press]

$$= P \cdot R_o / (S_n \cdot E + 0.4 \cdot P) \text{ per Appendix 1-1 (a) (1)}$$

$$= 2.6 \cdot 30.16 / (117.9 \cdot 1 + 0.4 \cdot 2.6)$$

$$= 0.6593 \text{ mm}$$

**UG-40, Limits of Reinforcement : [Internal Pressure]**

Parallel to Vessel Wall (Diameter Limit)	Dl	97.6996	mm
Parallel to Vessel Wall, opening length	d	48.8498	mm
Normal to Vessel Wall (Thickness Limit), no pad	Tlnp	10.4000	mm

Note:

*Taking a UG-36(c)(3)(a) exemption for nozzle: N2.  
 This calculation is valid for nozzles that meet all the requirements of paragraph UG-36. Please check the Code carefully, especially for nozzles that are not isolated or do not meet Code spacing requirements. To force the computation of areas for small nozzles go to Tools->Configuration and check the box to force the UG-37 small nozzle area calculation or force the Appendix 1-10 computation in Nozzle Design Options.*

**UG-45 Minimum Nozzle Neck Thickness Requirement: [Int. Press.]**

Wall Thickness for Internal/External pressures	ta	= 3.6593	mm
Wall Thickness per UG16(b),	tr16b	= 4.5000	mm
Wall Thickness, shell/head, internal pressure	trb1	= 5.3325	mm
Wall Thickness	tb1 = max(trb1, tr16b)	= 5.3325	mm
Wall Thickness	tb2 = max(trb2, tr16b)	= 4.5000	mm
Wall Thickness per table UG-45	tb3	= 6.4200	mm

Determine Nozzle Thickness candidate [tb]:

$$= \min[ tb3, \max( tb1, tb2 ) ]$$

$$= \min[ 6.42, \max( 5.332, 4.5 ) ]$$

$$= 5.3325 \text{ mm}$$

Minimum Wall Thickness of Nozzle Necks [tUG-45]:

$$= \max( ta, tb )$$

$$= \max( 3.659, 5.332 )$$

$$= 5.3325 \text{ mm}$$

Available Nozzle Neck Thickness =  $0.875 \cdot 8.738 = 7.645 \text{ mm} \rightarrow \text{OK}$

**Nozzle Junction Minimum Design Metal Temperature (MDMT) Calculations:**

**Nozzle Neck to Flange Weld, min( Curve:B, Curve:A)**

Govrn. thk, tg = 7.645, tr = 0.659, c = 3 mm, E\* = 1  
 Thickness Ratio =  $tr \cdot (E^*) / (tg - c) = 0.142$ , Temp. Reduction = 78 °C

Min Metal Temp. w/o impact per UCS-66, Curve A -8 °C

PV Elite 23 SP2 Licensee: PPV-Engineering B.V.

FileName : Instrument air outlet\_LI4732 -----

Nozzle Calcs.: N2 Nozl: 13 10:37am Apr 13,2022

Min Metal Temp. at Required thickness (UCS 66.1) -104 °C  
 Min Metal Temp. w/o impact per UG-20(f) -29 °C

**Nozzle-Shell/Head Weld (UCS-66(a)(b)), Curve: B**  
 -----

Govrn. thk, tg = 7.16, tr = 2.332, c = 3 mm, E\* = 1  
 Thickness Ratio =  $tr * (E*) / (tg - c) = 0.561$ , Temp. Reduction = 26 °C

Min Metal Temp. w/o impact per UCS-66, Curve B -29 °C  
 Min Metal Temp. at Required thickness (UCS 66.1) -48 °C

Gov. MDMT of the nozzle to shell joint welded assembly : -48 °C

**ANSI Flange MDMT including Temperature reduction per UCS-66.1:**

Unadjusted MDMT of ASME B16.5/47 flanges per UCS-66(c) -18 °C  
 Flange MDMT with Temp reduction per UCS-66(b)(1)(-b) -48 °C

Where the Stress Reduction Ratio per UCS-66(b)(1)(-b) is :

Design Pressure/Ambient Rating =  $2.60 / 5.11 = 0.509$

Weld Size Calculations, Description: N2

Intermediate Calc. for nozzle/shell Welds Tmin 5.1800 mm

**Results Per UW-16.1:**

	Required Thickness	Actual Thickness
Nozzle Weld	$3.6260 = 0.7 * t_{min}$	$4.2420 = 0.7 * W_o$ mm

Skipping the nozzle attachment weld strength calculations.  
 Per UW-15(b)(2) the nozzles exempted by UG-36(c)(3)(a)  
 (small nozzles) do not require a weld strength check.

**Maximum Allowable Pressure for this Nozzle at this Location:**

Converged Max. Allow. Pressure in Operating case 3.864 N/mm<sup>2</sup>

Note: The MAWP of this junction was limited by the parent Shell/Head.

The Drop for this Nozzle is : 4.5914 mm

The Cut Length for this Nozzle is, Drop + Ho + H + T : 85.7514 mm

Note: This nozzle or its diameter limit intersects weld seam # [3] on this element. The distance between the nozzle and seam is, 29.15 mm , while the distance from the center of the nozzle to the edge of the diameter limit is: 48.85 mm

**PV Elite is a trademark of Hexagon AB, 2021, All rights reserved.**

FileName : Instrument air outlet\_LI4732 -----

Nozzle Calcs.: N3

Nozl: 14 10:37am Apr 13,2022

**Input, Nozzle Desc: N3**

**From: 20**

Pressure for Reinforcement Calculations	P	2.6000	N/mm <sup>2</sup>
Temperature for Internal Pressure	Temp	210	°C
Parent Material		SA-106 B	
Parent Allowable Stress at Temperature	Sv	117.90	N/mm <sup>2</sup>
Parent Allowable Stress At Ambient	Sva	117.90	N/mm <sup>2</sup>
Inside Diameter of Cylindrical Shell	D	202.74	mm
Shell Finished (Minimum) Thickness	t	7.1600	mm
Shell Internal Corrosion Allowance	c	3.0000	mm
Shell External Corrosion Allowance	co	0.0000	mm
Distance from Bottom/Left Tangent		201.31	mm
User Entered Minimum Design Metal Temperature		-28.89	°C

**Type of Element Connected to the Parent : Nozzle**

Material		SA-106 B	
Material UNS Number		K03006	
Material Specification/Type		Smls. pipe	
Allowable Stress at Temperature	Sn	117.90	N/mm <sup>2</sup>
Allowable Stress At Ambient	Sna	117.90	N/mm <sup>2</sup>
Diameter Basis (for tr calc only)		Outside	
Layout Angle		270.00	deg
Diameter		38.1000	mm
Size and Thickness Basis		Actual	
Actual Thickness	tn	8.3820	mm
Corrosion Allowance	can	3.0000	mm
Joint Efficiency of Shell Seam at Nozzle	E1	1.00	
Joint Efficiency of Nozzle Neck	En	1.00	
Outside Projection	ho	47.6250	mm
Weld leg size between Nozzle and Pad/Shell	Wo	6.0000	mm
Groove weld depth between Nozzle and Vessel	Wgnv	8.3400	mm

The Pressure Design option was Design Pressure + static head.

**Nozzle Sketch (may not represent actual weld type/configuration)**

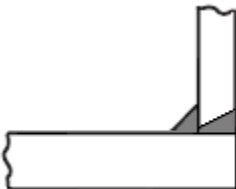

**Abutting/Set-on Nozzle No Pad**

**Reinforcement CALCULATION, Description: N3**

ASME Code, Section VIII, Div. 1, 2019, UG-37 to UG-45

FileName : Instrument air outlet\_LI4732 -----

Nozzle Calcs.: N3 Nozl: 14 10:37am Apr 13,2022

Actual Outside Diameter Used in Calculation 38.100 mm.  
 Actual Thickness Used in Calculation 8.382 mm

Nozzle input data check completed without errors.

Reqd thk per UG-37(a) of Cylindrical Shell, tr [Int. Press]

$$= P \cdot R / (S_v \cdot E - 0.6 \cdot P) \text{ per UG-27 (c) (1)}$$

$$= 2.6 \cdot 104.4 / (117.9 \cdot 1 - 0.6 \cdot 2.6)$$

$$= 2.3325 \text{ mm}$$

Reqd thk per UG-37(a) of Nozzle Wall, trn [Int. Press]

$$= P \cdot R_o / (S_n \cdot E + 0.4 \cdot P) \text{ per Appendix 1-1 (a) (1)}$$

$$= 2.6 \cdot 19.05 / (117.9 \cdot 1 + 0.4 \cdot 2.6)$$

$$= 0.4164 \text{ mm}$$

**UG-40, Limits of Reinforcement : [Internal Pressure]**

Parallel to Vessel Wall (Diameter Limit)	D1	54.6720	mm
Parallel to Vessel Wall, opening length	d	27.3360	mm
Normal to Vessel Wall (Thickness Limit), no pad	Tlnp	10.4000	mm

Note:

*Taking a UG-36(c)(3)(a) exemption for nozzle: N3.  
 This calculation is valid for nozzles that meet all the requirements of paragraph UG-36. Please check the Code carefully, especially for nozzles that are not isolated or do not meet Code spacing requirements. To force the computation of areas for small nozzles go to Tools->Configuration and check the box to force the UG-37 small nozzle area calculation or force the Appendix 1-10 computation in Nozzle Design Options.*

**UG-45 Minimum Nozzle Neck Thickness Requirement: [Int. Press.]**

Wall Thickness for Internal/External pressures	ta = 3.4164	mm
Wall Thickness per UG16(b),	tr16b = 4.5000	mm
Wall Thickness, shell/head, internal pressure	trb1 = 5.3325	mm
Wall Thickness	tb1 = max(trb1, tr16b) = 5.3325	mm
Wall Thickness	tb2 = max(trb2, tr16b) = 4.5000	mm
Wall Thickness per table UG-45	tb3 = 6.1200	mm

Determine Nozzle Thickness candidate [tb]:

$$= \min[ tb3, \max( tb1, tb2 ) ]$$

$$= \min[ 6.12, \max( 5.332, 4.5 ) ]$$

$$= 5.3325 \text{ mm}$$

Minimum Wall Thickness of Nozzle Necks [tUG-45]:

$$= \max( ta, tb )$$

$$= \max( 3.416, 5.332 )$$

$$= 5.3325 \text{ mm}$$

Available Nozzle Neck Thickness = 8.3820 mm --> OK

**Nozzle Junction Minimum Design Metal Temperature (MDMT) Calculations:**

**Nozzle-Shell/Head Weld (UCS-66(a)1(b)), Curve: B**

Govrn. thk, tg = 7.16, tr = 2.332, c = 3 mm, E\* = 1  
 Thickness Ratio = tr \* (E\*) / (tg - c) = 0.561, Temp. Reduction = 26 °C

Min Metal Temp. w/o impact per UCS-66, Curve B	-29 °C
Min Metal Temp. at Required thickness (UCS 66.1)	-48 °C

Gov. MDMT of the nozzle to shell joint welded assembly : -48 °C

Weld Size Calculations, Description: N3

Intermediate Calc. for nozzle/shell Welds Tmin 5.1800 mm

**Results Per UW-16.1:**

	Required Thickness	Actual Thickness
Nozzle Weld	$3.6260 = 0.7 * t_{min}$	$4.2420 = 0.7 * W_o$ mm

Skipping the nozzle attachment weld strength calculations.  
Per UW-15(b)(2) the nozzles exempted by UG-36(c)(3)(a)  
(small nozzles) do not require a weld strength check.

**Maximum Allowable Pressure for this Nozzle at this Location:**

Converged Max. Allow. Pressure in Operating case 3.864 N/mm<sup>2</sup>

Note: The MAWP of this junction was limited by the parent Shell/Head.

The Drop for this Nozzle is : 1.8061 mm

The Cut Length for this Nozzle is, Drop + Ho + H + T : 56.5911 mm

**PV Elite is a trademark of Hexagon AB, 2021, All rights reserved.**

FileName : Instrument air outlet\_LI4732 -----

Nozzle Calcs.: Noz N1 Nozl: 15 10:37am Apr 13,2022

**Input, Nozzle Desc: Noz N1 From: 30**

Pressure for Reinforcement Calculations	P	2.6000	N/mm <sup>2</sup>
Temperature for Internal Pressure	Temp	210	°C
Parent Material		SA-234 WPB	
Parent Allowable Stress at Temperature	Sv	117.90	N/mm <sup>2</sup>
Parent Allowable Stress At Ambient	Sva	117.90	N/mm <sup>2</sup>
Inside Diameter of Elliptical Head	D	202.74	mm
Aspect Ratio of Elliptical Head	Ar	2.00	
Head Finished (Minimum) Thickness	t	8.1800	mm
Head Internal Corrosion Allowance	c	3.0000	mm
Head External Corrosion Allowance	co	0.0000	mm
Distance from Head Centerline	L1	0.0000	mm
User Entered Minimum Design Metal Temperature		-28.89	°C

**Type of Element Connected to the Parent : Nozzle**

Material		SA-106 B	
Material UNS Number		K03006	
Material Specification/Type		Smls. pipe	
Allowable Stress at Temperature	Sn	117.90	N/mm <sup>2</sup>
Allowable Stress At Ambient	Sna	117.90	N/mm <sup>2</sup>
Diameter Basis (for tr calc only)		Outside	
Layout Angle		0.00	deg
Diameter		50.0000	mm
Size and Thickness Basis		Nominal	
Nominal Thickness		160	
Flange Material		SA-105	
Flange Type		Weld Neck Flange	
Corrosion Allowance	can	3.0000	mm
Joint Efficiency of Shell Seam at Nozzle	E1	1.00	
Joint Efficiency of Nozzle Neck	En	1.00	
Outside Projection	ho	63.0000	mm
Weld leg size between Nozzle and Pad/Shell	Wo	6.0000	mm
Groove weld depth between Nozzle and Vessel	Wgnv	7.1600	mm
Flange Class		300	
Flange Grade		GR 1.1	

The Pressure Design option was Design Pressure + static head.

**Nozzle Sketch (may not represent actual weld type/configuration)**

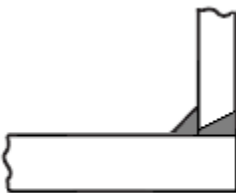

**Abutting/Set-on Nozzle No Pad**

**Reinforcement CALCULATION, Description: Noz N1**

ASME Code, Section VIII, Div. 1, 2019, UG-37 to UG-45

Actual Outside Diameter Used in Calculation 60.325 mm.  
 Actual Thickness Used in Calculation 8.738 mm

Nozzle input data check completed without errors.

Reqd thk per UG-37(a) of Elliptical Head, tr [Int. Press]  
 =  $P \cdot D \cdot K1 / (2 \cdot Sv \cdot E - 0.2 \cdot P)$  per Appendix 1-4(c)  
 =  $0.876 \cdot 2.6 \cdot 208.7 / (2 \cdot 117.9 \cdot 1 - 0.2 \cdot 2.6)$   
 = 2.0208 mm

Reqd thk per UG-37(a) of Nozzle Wall, trn [Int. Press]  
 =  $P \cdot Ro / (Sn \cdot E + 0.4 \cdot P)$  per Appendix 1-1 (a) (1)  
 =  $2.6 \cdot 30.16 / (117.9 \cdot 1 + 0.4 \cdot 2.6)$   
 = 0.6593 mm

**UG-40, Limits of Reinforcement : [Internal Pressure]**

Parallel to Vessel Wall (Diameter Limit) D1 97.6996 mm  
 Parallel to Vessel Wall, opening length d 48.8498 mm  
 Normal to Vessel Wall (Thickness Limit), no pad Tlnp 12.9500 mm

Note:

*Taking a UG-36(c)(3)(a) exemption for nozzle: Noz N1.  
 This calculation is valid for nozzles that meet all the requirements of  
 paragraph UG-36. Please check the Code carefully, especially for nozzles  
 that are not isolated or do not meet Code spacing requirements. To force  
 the computation of areas for small nozzles go to Tools->Configuration  
 and check the box to force the UG-37 small nozzle area calculation or  
 force the Appendix 1-10 computation in Nozzle Design Options.*

**UG-45 Minimum Nozzle Neck Thickness Requirement: [Int. Press.]**

Wall Thickness for Internal/External pressures ta = 3.6593 mm  
 Wall Thickness per UG16(b), tr16b = 4.5000 mm  
 Wall Thickness, shell/head, internal pressure trb1 = 5.2220 mm  
 Wall Thickness tb1 = max(trb1, tr16b) = 5.2220 mm  
 Wall Thickness tb2 = max(trb2, tr16b) = 4.5000 mm  
 Wall Thickness per table UG-45 tb3 = 6.4200 mm

Determine Nozzle Thickness candidate [tb]:

= min[ tb3, max( tb1, tb2 ) ]  
 = min[ 6.42, max( 5.222, 4.5 ) ]  
 = 5.2220 mm

Minimum Wall Thickness of Nozzle Necks [tUG-45]:

= max( ta, tb )  
 = max( 3.659, 5.222 )  
 = 5.2220 mm

Available Nozzle Neck Thickness =  $0.875 \cdot 8.738 = 7.645$  mm --> OK

**Nozzle Junction Minimum Design Metal Temperature (MDMT) Calculations:**

**Nozzle Neck to Flange Weld, Curve: B**

-----  
 Govern. thk, tg = 7.645, tr = 0.659, c = 3 mm, E\* = 1  
 Thickness Ratio =  $tr \cdot (E^*) / (tg - c) = 0.142$ , Temp. Reduction = 78 °C

PV Elite 23 SP2 Licensee: PPV-Engineering B.V.

FileName : Instrument air outlet\_LI4732 -----

Nozzle Calcs.: Noz N1 Nozl: 15 10:37am Apr 13,2022

Min Metal Temp. w/o impact per UCS-66, Curve B -29 °C  
 Min Metal Temp. at Required thickness (UCS 66.1) -104 °C

**Nozzle-Shell/Head Weld (UCS-66(a)1(b)), Curve: B**  
 -----

Govrn. thk, tg = 7.645, tr = 0.659, c = 3 mm, E\* = 1  
 Thickness Ratio =  $tr * (E*) / (tg - c) = 0.142$ , Temp. Reduction = 78 °C

Min Metal Temp. w/o impact per UCS-66, Curve B -29 °C  
 Min Metal Temp. at Required thickness (UCS 66.1) -104 °C

Gov. MDMT of the nozzle to shell joint welded assembly : -104 °C

**ANSI Flange MDMT including Temperature reduction per UCS-66.1:**

Unadjusted MDMT of ASME B16.5/47 flanges per UCS-66(c) -18 °C  
 Flange MDMT with Temp reduction per UCS-66(b)(1)(-b) -48 °C

Where the Stress Reduction Ratio per UCS-66(b)(1)(-b) is :

Design Pressure/Ambient Rating =  $2.60 / 5.11 = 0.509$

Weld Size Calculations, Description: Noz N1

Intermediate Calc. for nozzle/shell Welds Tmin 5.1800 mm

**Results Per UW-16.1:**

	Required Thickness	Actual Thickness
Nozzle Weld	$3.6260 = 0.7 * t_{min}$	$4.2420 = 0.7 * W_o$ mm

Skipping the nozzle attachment weld strength calculations.  
 Per UW-15(b)(2) the nozzles exempted by UG-36(c)(3)(a)  
 (small nozzles) do not require a weld strength check.

**Maximum Allowable Pressure for this Nozzle at this Location:**

Converged Max. Allow. Pressure in Operating case 4.83 N/mm<sup>2</sup>

Note: The MAWP of this junction was limited by the parent Shell/Head.

The Drop for this Nozzle is : 2.4222 mm

The Cut Length for this Nozzle is, Drop + Ho + H + T : 73.6022 mm

**PV Elite is a trademark of Hexagon AB, 2021, All rights reserved.**