







OWNER:  شرکت سست و سویی توهمه ایران (سهامی خاص)	BUSHEHR PETROCHEMICAL COMPANY MEG PLANT						EPC CONTRACTOR:  Chagalesh-Enerchimi-Steam Joint Venture BUPC-MEG PLANT PROJECT		
	PULSATION DAMPER DETAIL DRAWING FOR EMERGENCY INSTRUMENT AIR COMPRESSOR								
MC :  شرکت سست و سویی توهمه ایران (سهامی خاص)	Project	Area	Phase	Unit	Dis.	Doc.	Seq.	Contract No : 52-98/445	
Owner Document Number: 17811-23D	BU	20	VD	303	ME	DWG	0080	Rev.:	Page
								03	1 of 4

Repetitive comment:
wind and seismic effect for design of equipment shall
be considered by vendor.

PULSATION DAMPER DETAIL DRAWING FOR EMERGENCY INSTRUMENT AIR COMPRESSOR

 شرکت سست و سویی توهمه ایران (سهامی خاص)	 Chagalesh-Enerchimi-Steam Joint Venture BUPC-MEG PLANT PROJECT	BUSHEHR PETROCHEMICAL COMPANY MEG PLANT
Document Review		
Issue Purpose:	AFC	
Result Code: AP,AN,CM,RE,NC	AN	
Next Status : IFC,IFA,IFI,AFC,AB	AFC	
Responsible Department	MECHANICAL	
Commented Date	May/15/2022	
Approval or review hereunder shall not be construed to relieve Vendor / Subcontractor of his responsibilities and liability under the contract.		

03	13/05/2022	Approved for Construction	KP	CL	JR	
02	06/05/2022	Approved for Construction	KP	CL	JR	
01	26/04/2022	For approval	KP	CL	JR	
00	06/04/2022	For approval	KP	CL	JR	
Rev.	Date	Purpose of Issue	Prepared	Checked	Approved	AC Code
					Class: 1	Phase: P

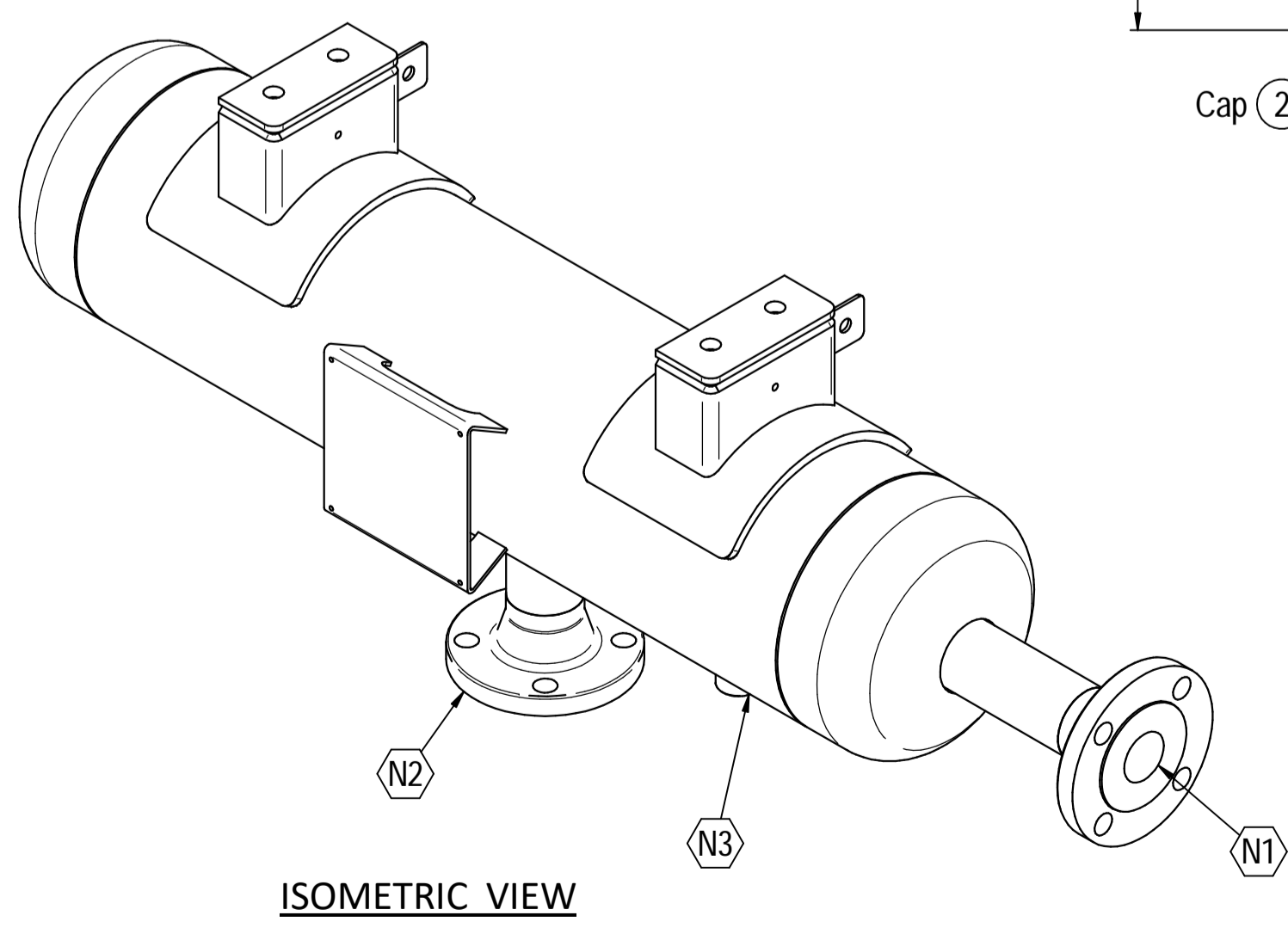
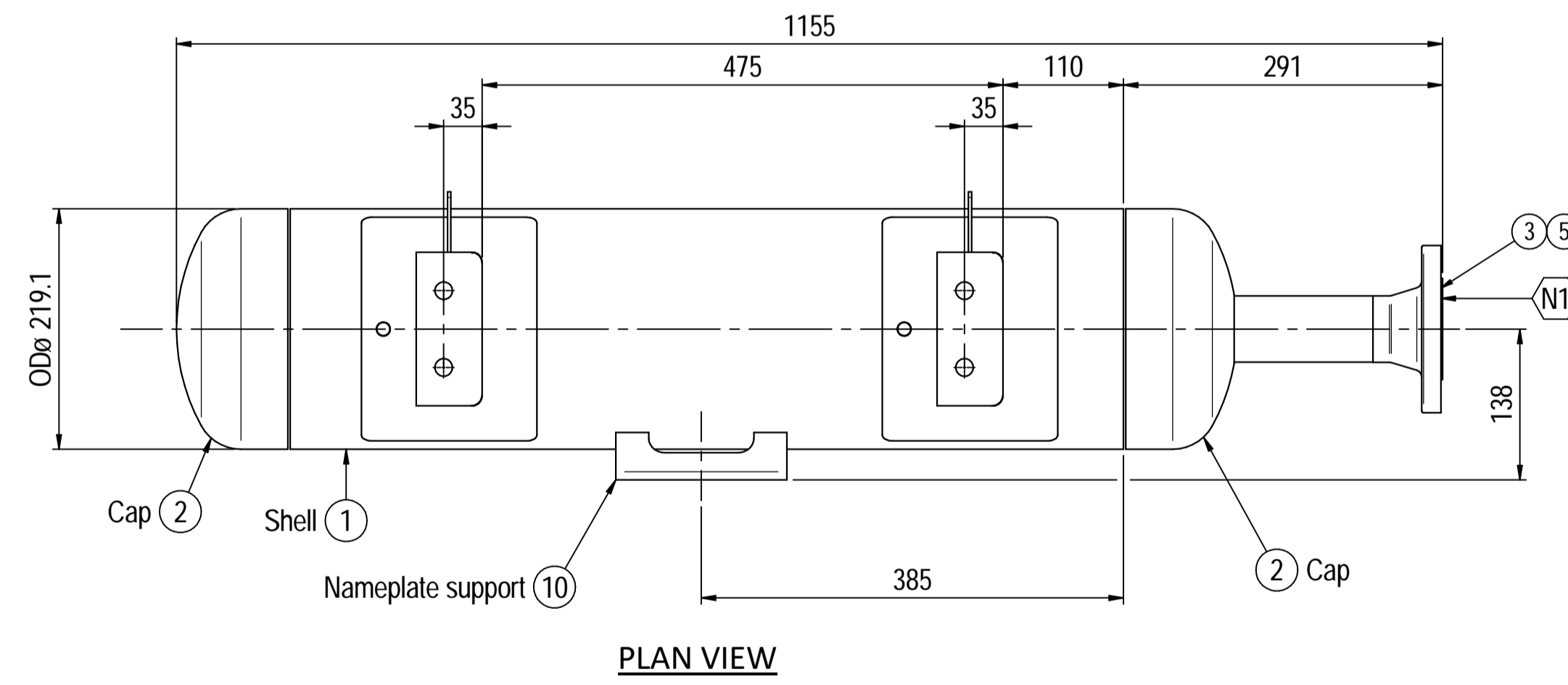
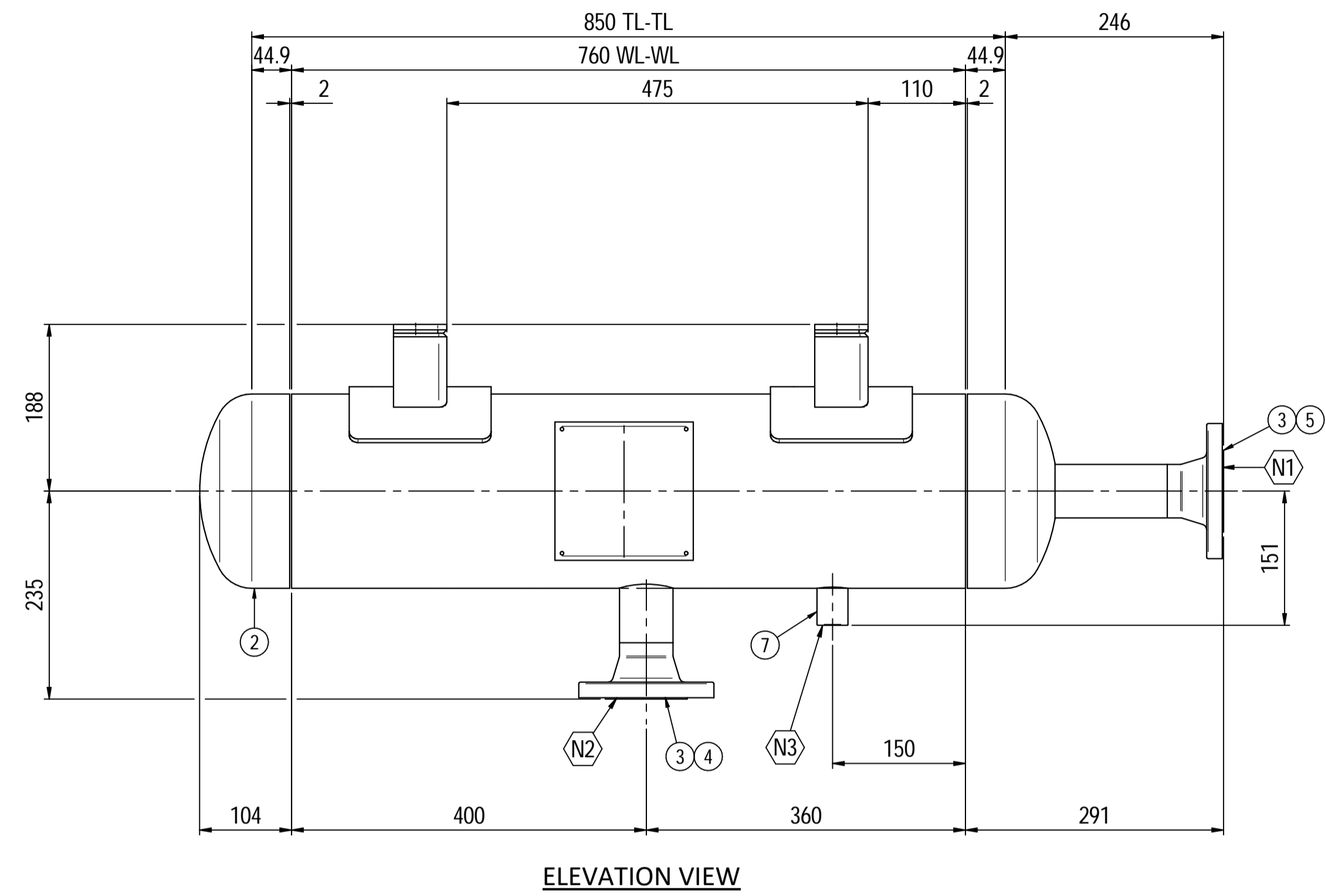
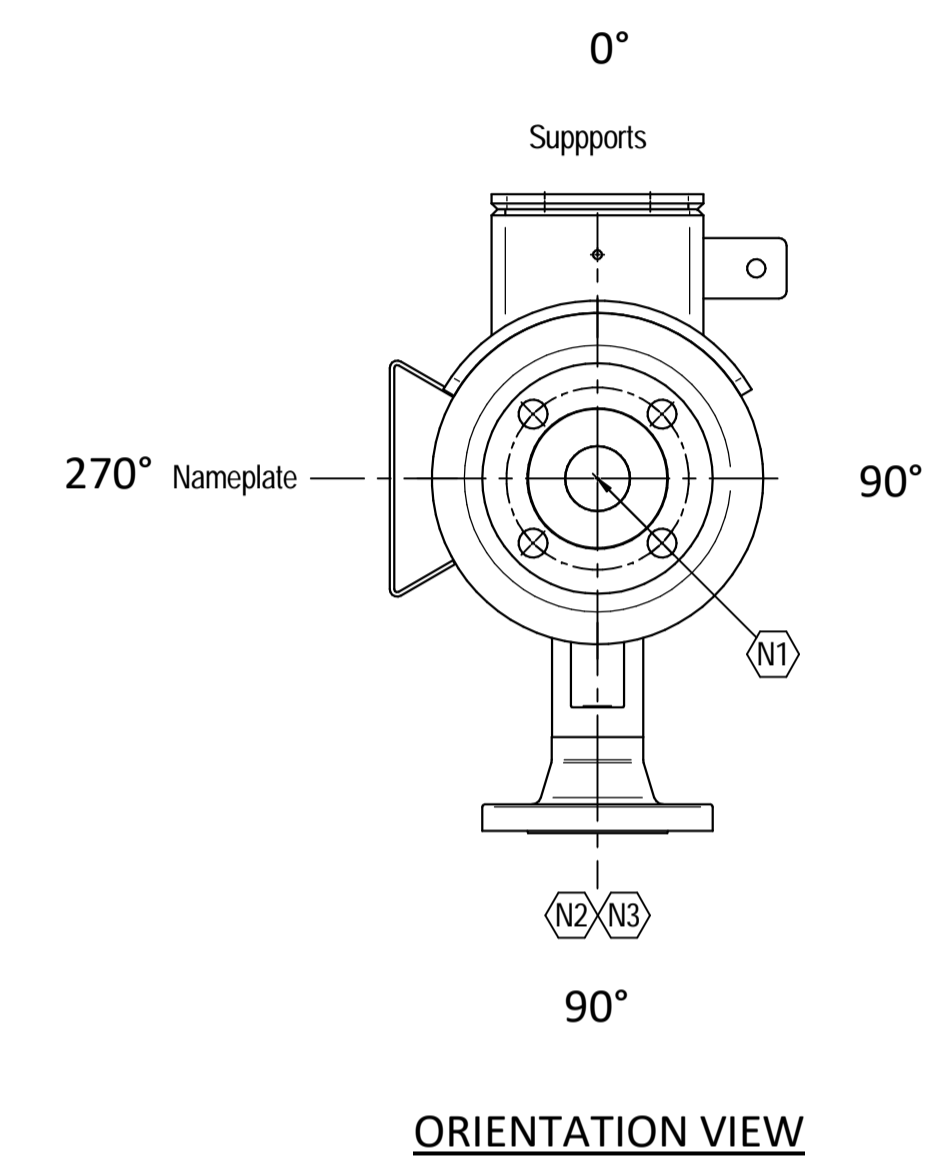
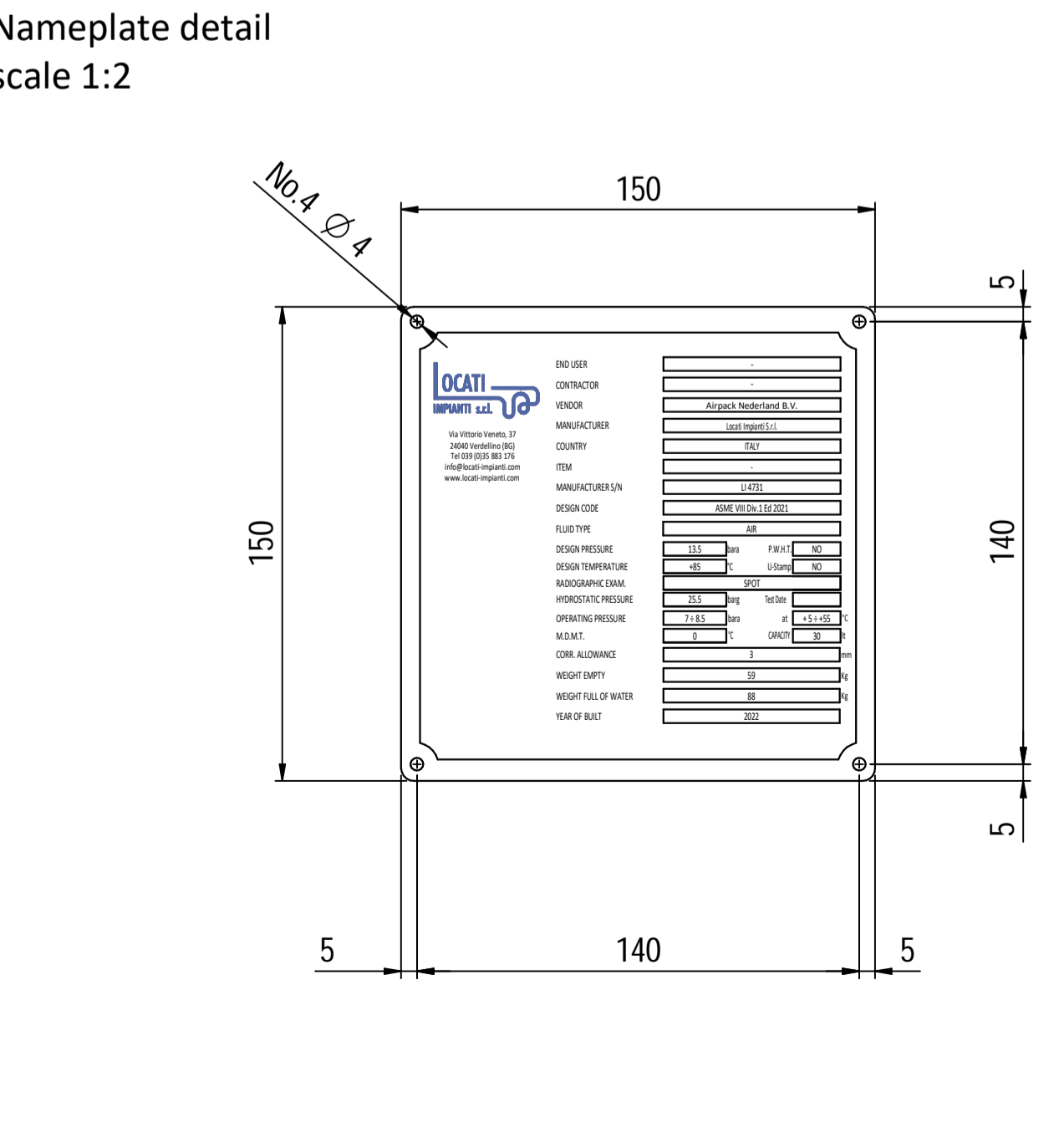
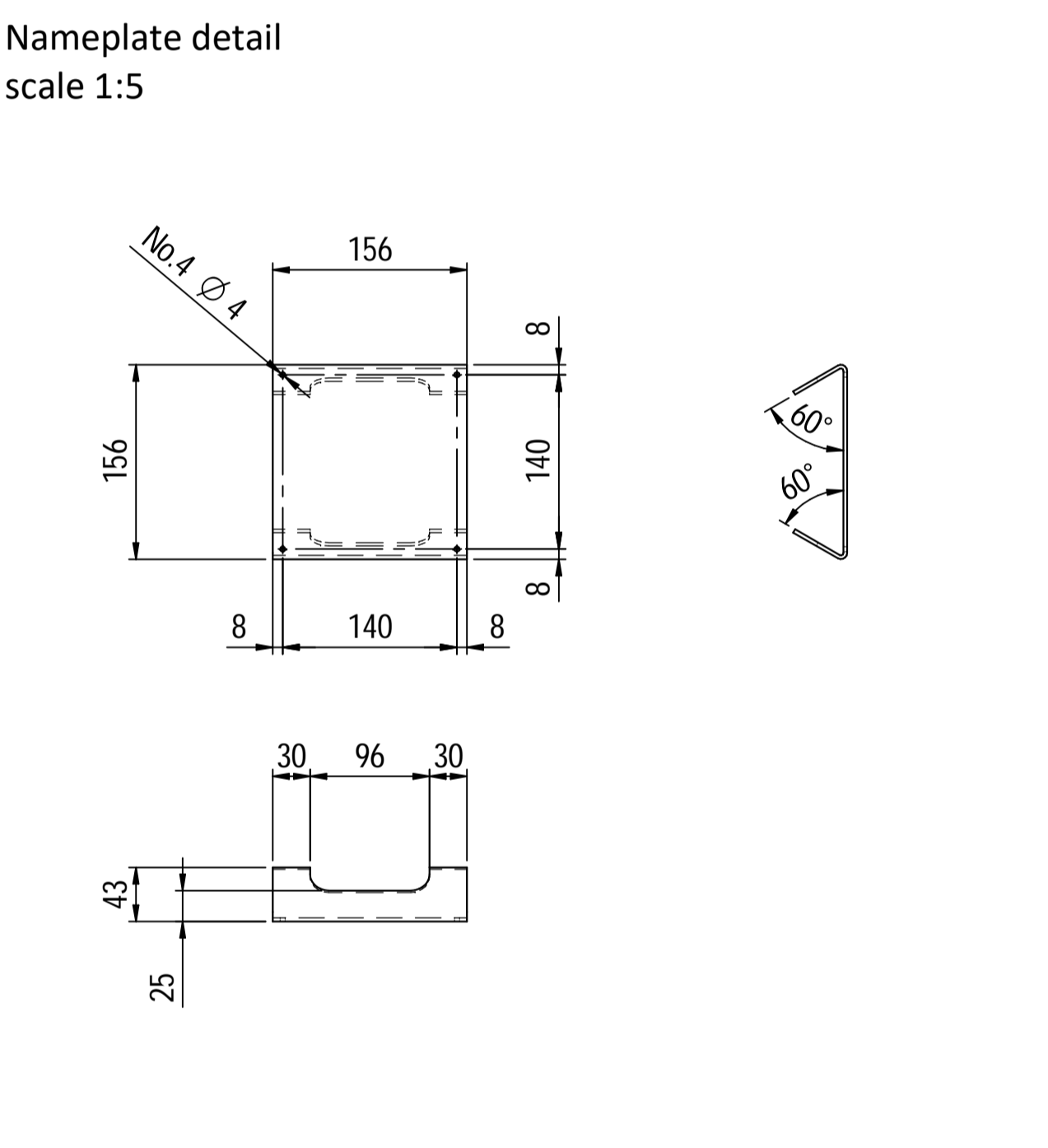
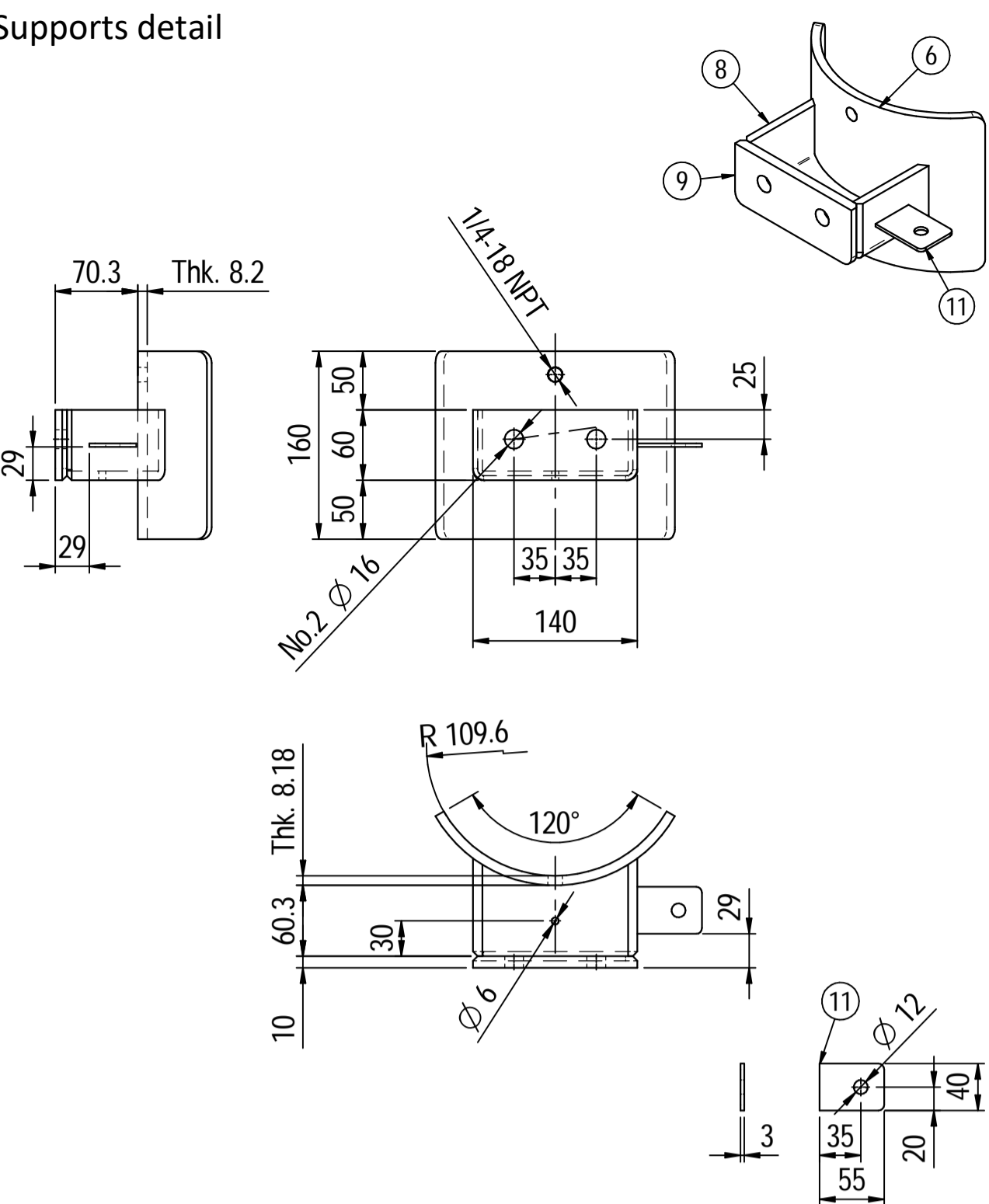

Material List					
Pos.	Q.ty	Description	Mat.	Cert.	
1	1	Shell by seamless pipe 8" Sch.40 L=760	A106 Gr.B	3.1	
2	2	Cap 8" Sch40	A234 WPB	3.1	
3	2	Flange 2" WN 150# Sch160	SA105	3.1	
4	1	Seamless pipe 2" Sch160 L=74	A106 Gr.B	3.1	
5	1	Seamless pipe 2" Sch160 L=72	A106 Gr.B	3.1	
6	2	Pad by pipe 8" Sch.40	A106 Gr.B	3.1	
7	1	Coupling 1/2" NPT #6000	A105	3.1	
8	2	Plate 83x231 Thk.8	A516 70	3.1	
9	2	Plate 60x140 Thk.10	A516 70	3.1	
10	1	Nameplate support 156x241 Thk.3mm	A516 70	3.1	
11	2	Earthing Plate 55 x 40 Thk.3	A240 TP316L	3.1	

Note:
 1) Governing measurement S.I. unless otherwise specified;
 2) Flange bolt holes have to be straddled from main vessel center line in plan & vertical & horizontal centreline in elevation;
 3) Material: certification 3.1 EN 10204;
 4) All internal edge shall be rounded off;
 5) Nozzle fittings in accordance with ASME B16.5: 2013;
 6) Flange fittings in accordance with ASME B16.9: 2012;
 7) The flange dimensions are in accordance to ASME B16.5: 2013;
 8) All fillet welds not detailed on "WELDING MAP" or drawing shall have the weld; throated equal to 0,7 times the minimum thickness to be welded;
 9) All welds are continuous except where indicate;
 10) See document C220006CLC007 for vessel calculation.

ITEM	QTY	SERVICE	SIZE	O.D.	THK	RATING	TYPE	FACE	O.D.	THK.	Tc
N3	1	DRAIN	1/2"	38.1	8.38	#6000	-	NPT-F	-	-	8.5 + 10
N2	1	AIR OUTLET	2"	60.3	8.74	#150	WN	RF	-	-	8.5 + 10
N1	1	AIR INLET	2"	60.3	8.74	#150	WN	RF	-	-	8.5 + 10

DATI DI PROGETTO / Design data			
FLUIDO	Air	COLLAUDO	Test
STATO FISICO DEL FLUIDO	Gas	NATIONAL BOARD REGISTRATION	NO
STATO FISICO DEL FLUIDO	Gas	NATIONAL BOARD REGISTRATION	NO
CODICE DI CALCOLO	ASME VIII Div. 1 Ed.2021	CANADIAN REGISTER NUMBER	NO
PRESSIONE DI ESERCIZIO	7 + 8.5 bara	SERVIZIO LETALE	NO
PRESSIONE DI PROGETTO	13.5 bara (12.5 barg)	R-T EXAMINATION	Spot (RT3)
PRESSIONE ESTERNA	NO	LICUIDI PENETRANTI	NO
PRESSIONE DI PROVA IDRAULICA	25.5 barg	ULTRASUONI	NO
TEMPERATURA DI ESERCIZIO	5 + 55°C	CONTROLLO MAGNETOSCOPICO	NO
TEMPERATURA DI PROGETTO	85 °C	WELD TEST COUPON	NO
SOVRAME TALLO DI CORROSIONE	3 mm	PROCEDIMENTO DI SALDATURA	See doc: C220006WBK013
CAPACITA'	30 l	TIPO DI FONDO	CAP
EFFICIENZA GIUNTI	0.85	FORMATURA FONDO	HOT
MAWP @ Design Temperature	18.15 barg @ +85°C	PESO A VUOTO	59 kg
MAWP(EXT)	NO	PESO IN ESERCIZIO	59 kg
MDMT @ MAWP	0 °C @ 18.15 barg	PESO PIENO D'ACQUA	88 kg
TRATTAMENTO TERMICO	NO	DATI DEL VENTO	-
IMPACT TEST	NO	DATI SISMICI	-

Rev.	Descrizione / Description	Disegnato/Draw	Controllato/Checked	Approvato/Approved	Data/Date
04	Modified as per Client comments	CM	MV	GL	11/05/2022
03	Modified as per Client comments	CM	MV	GL	15/04/2022
02	Modified as per Customer comments	CM	MV	GL	02/04/2022
01	Modified earthing lug	CM	MV	GL	25/03/2022
00	FIRST ISSUE	CM	MV	GL	16/03/2022

Objetto/Object: PULSATION DAMPER INLET

Scale/Scale: 1 : 5
 Comm. N°/Job No.: C220006
 Cliente/Customer: Airpack Nederland B.V.
 Ord. No.: 18498-VV-0901
 Dis. N°/Dwg No.: C220006DWG001
 Rev.: 04

LOCATI IMPIANTI s.r.l.

Supports detail

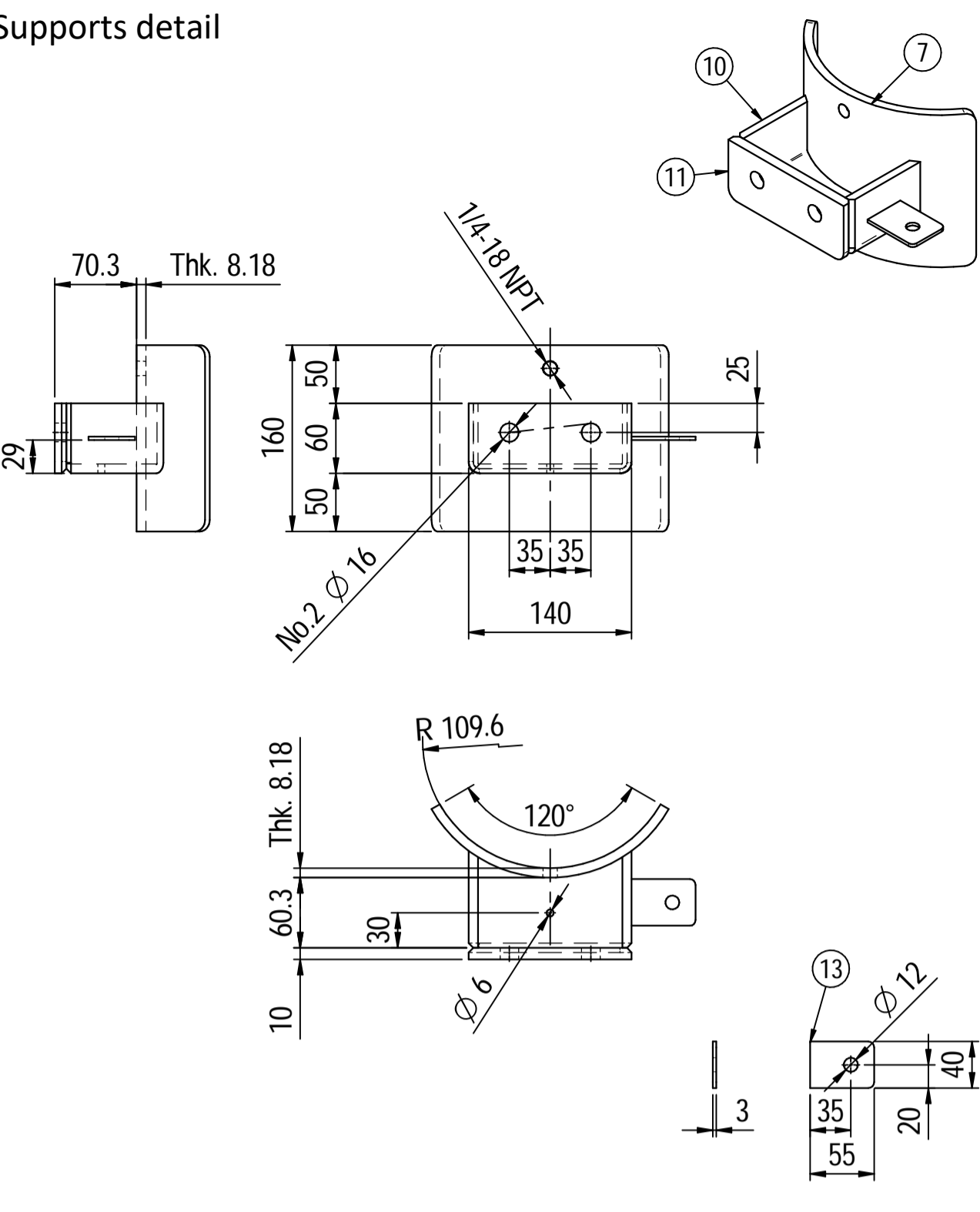

Nameplate support detail scale 1:5

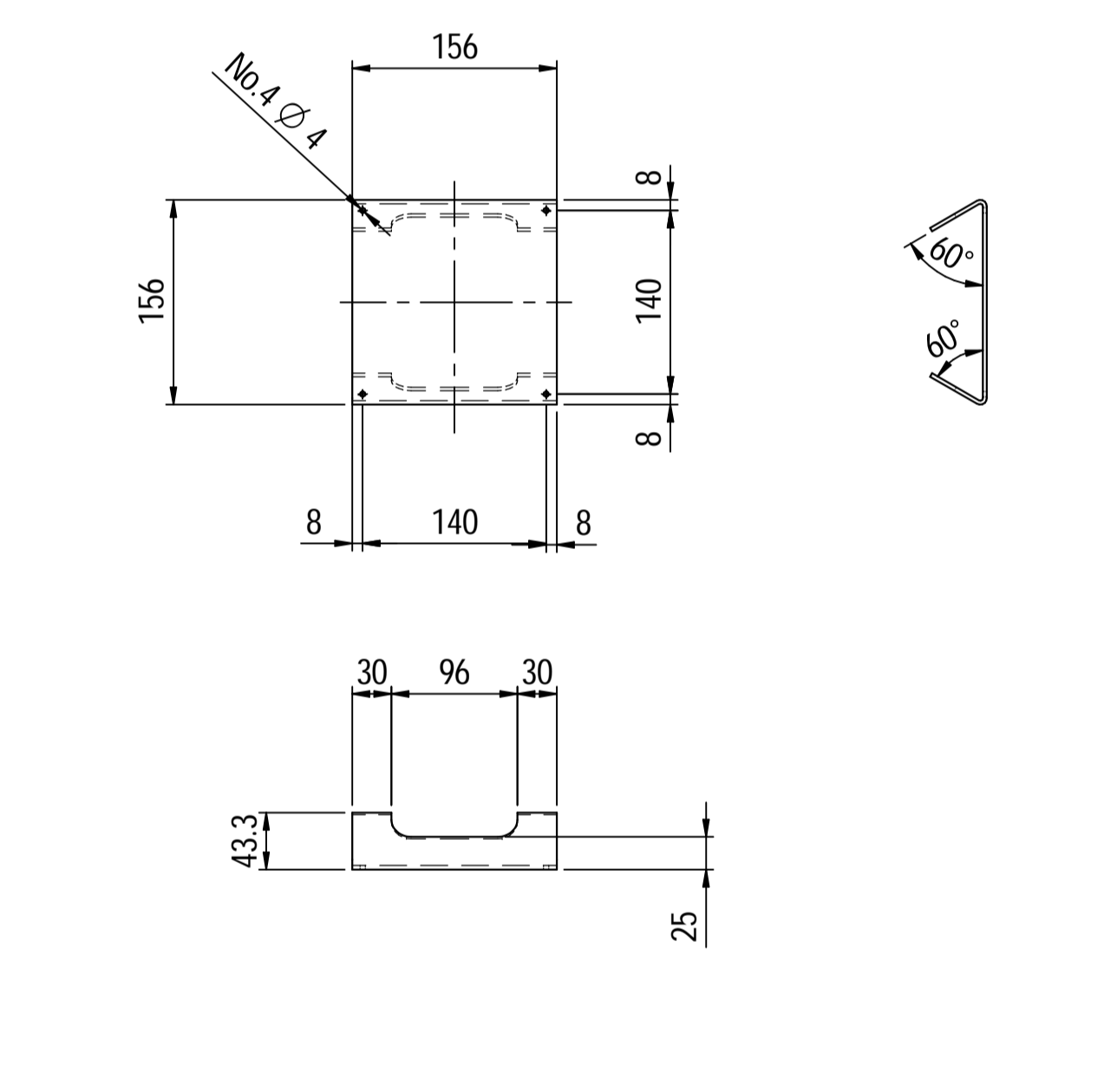

Nameplate detail scale 1:2

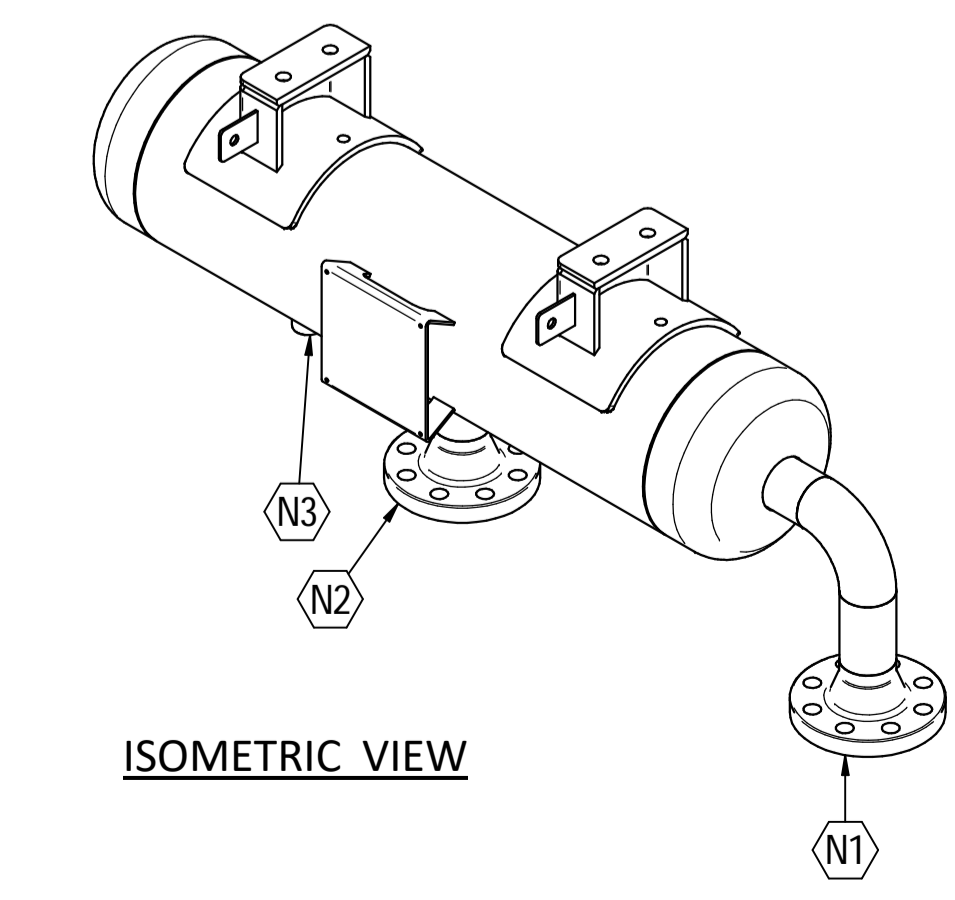
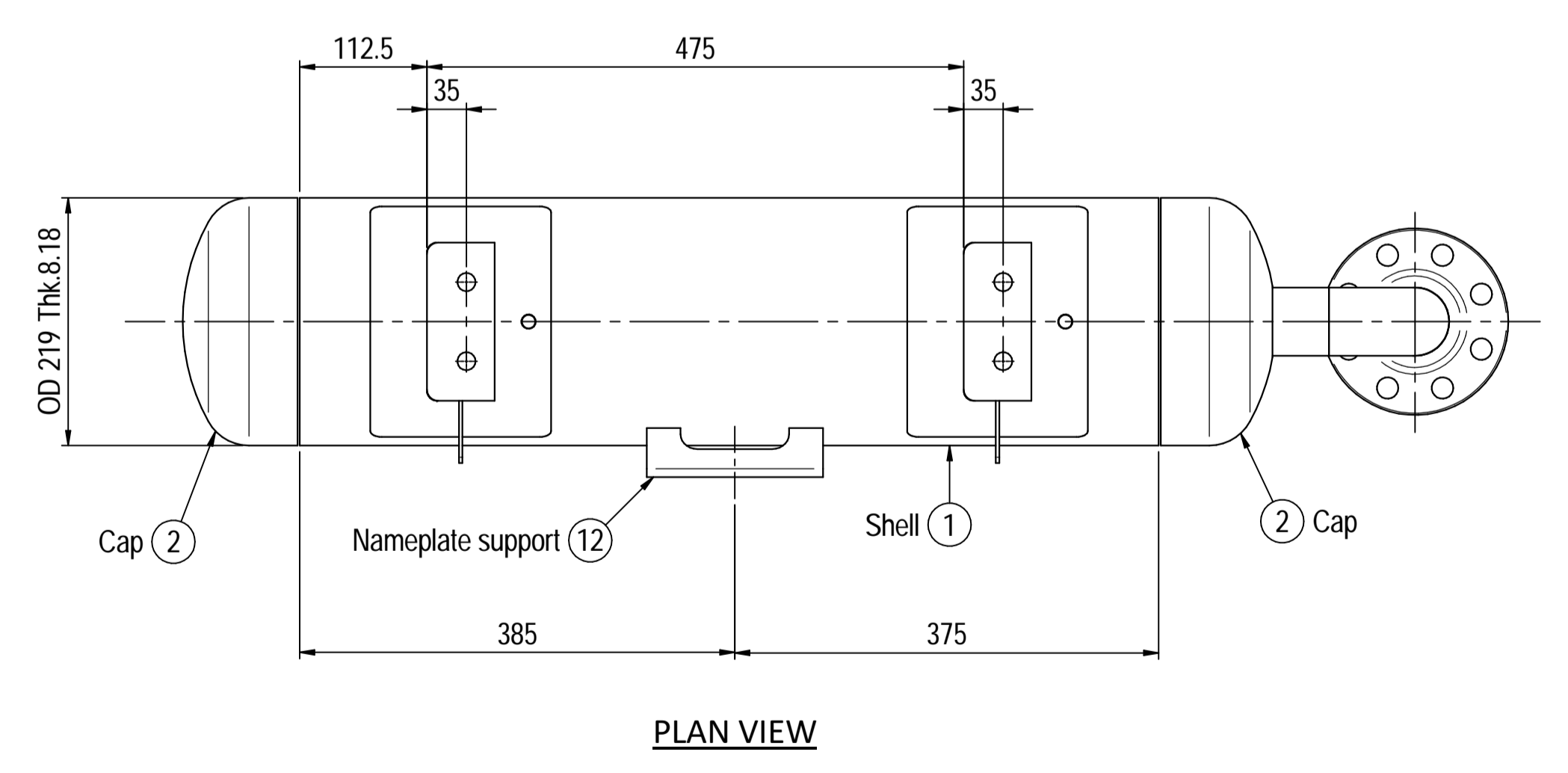
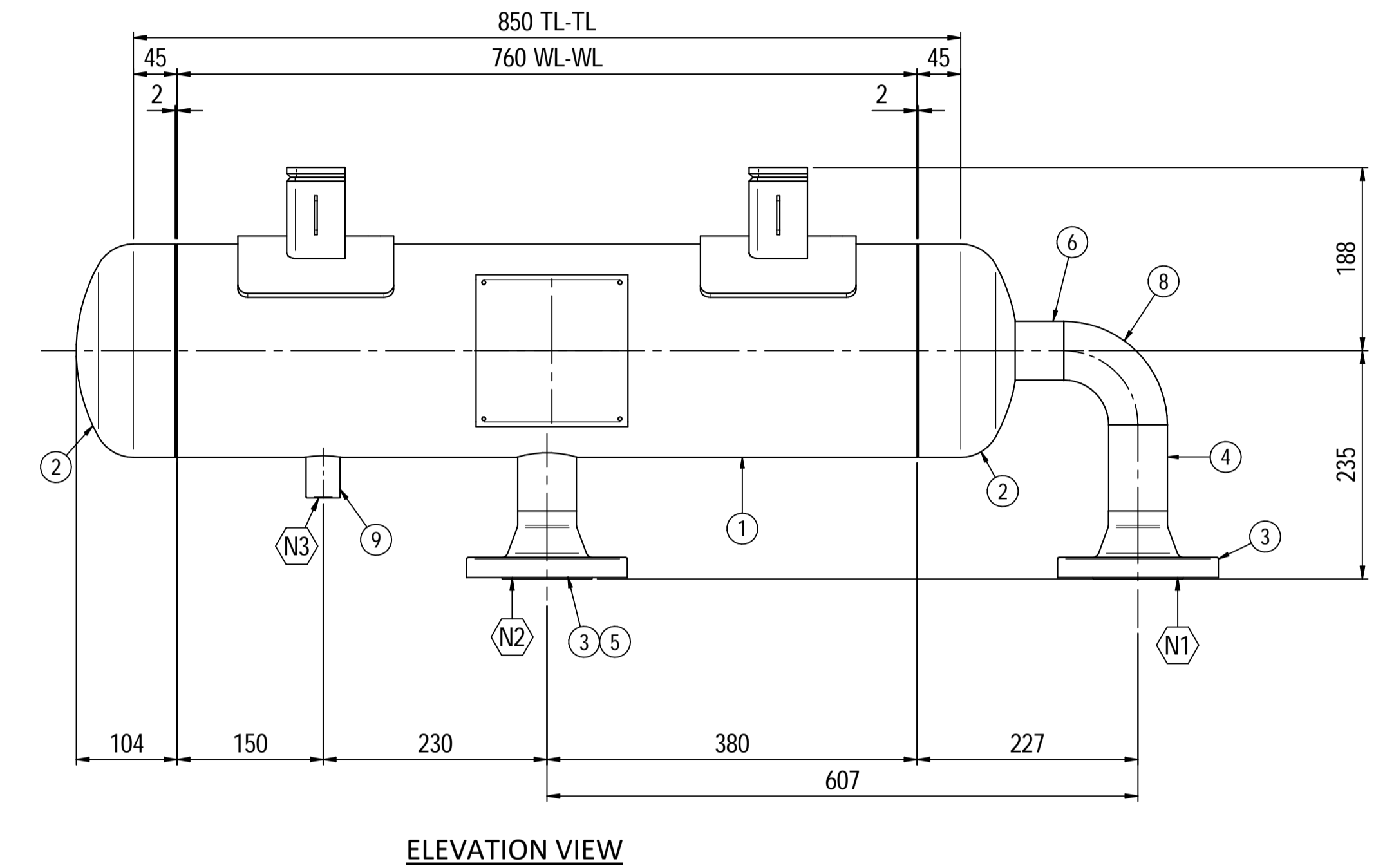
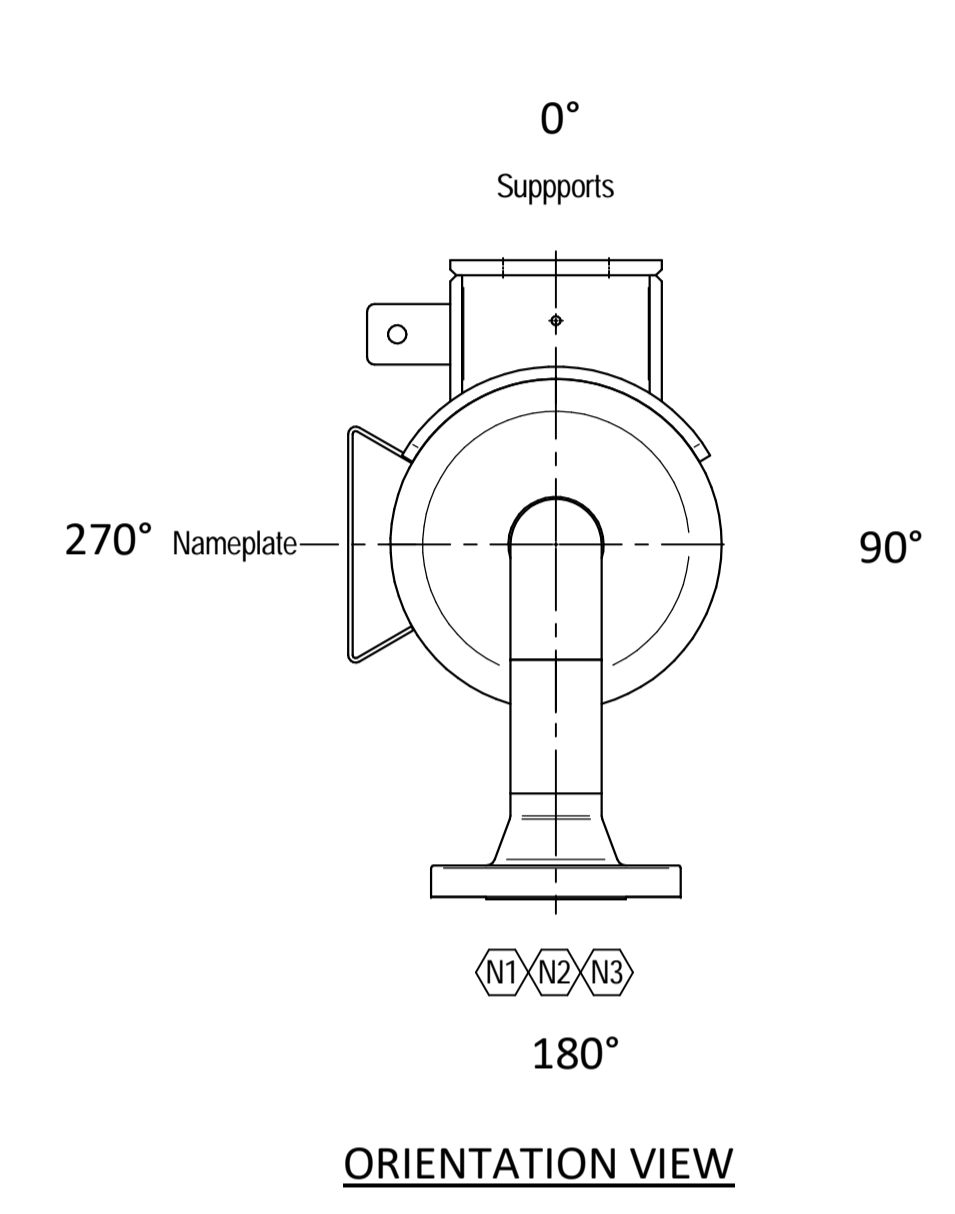
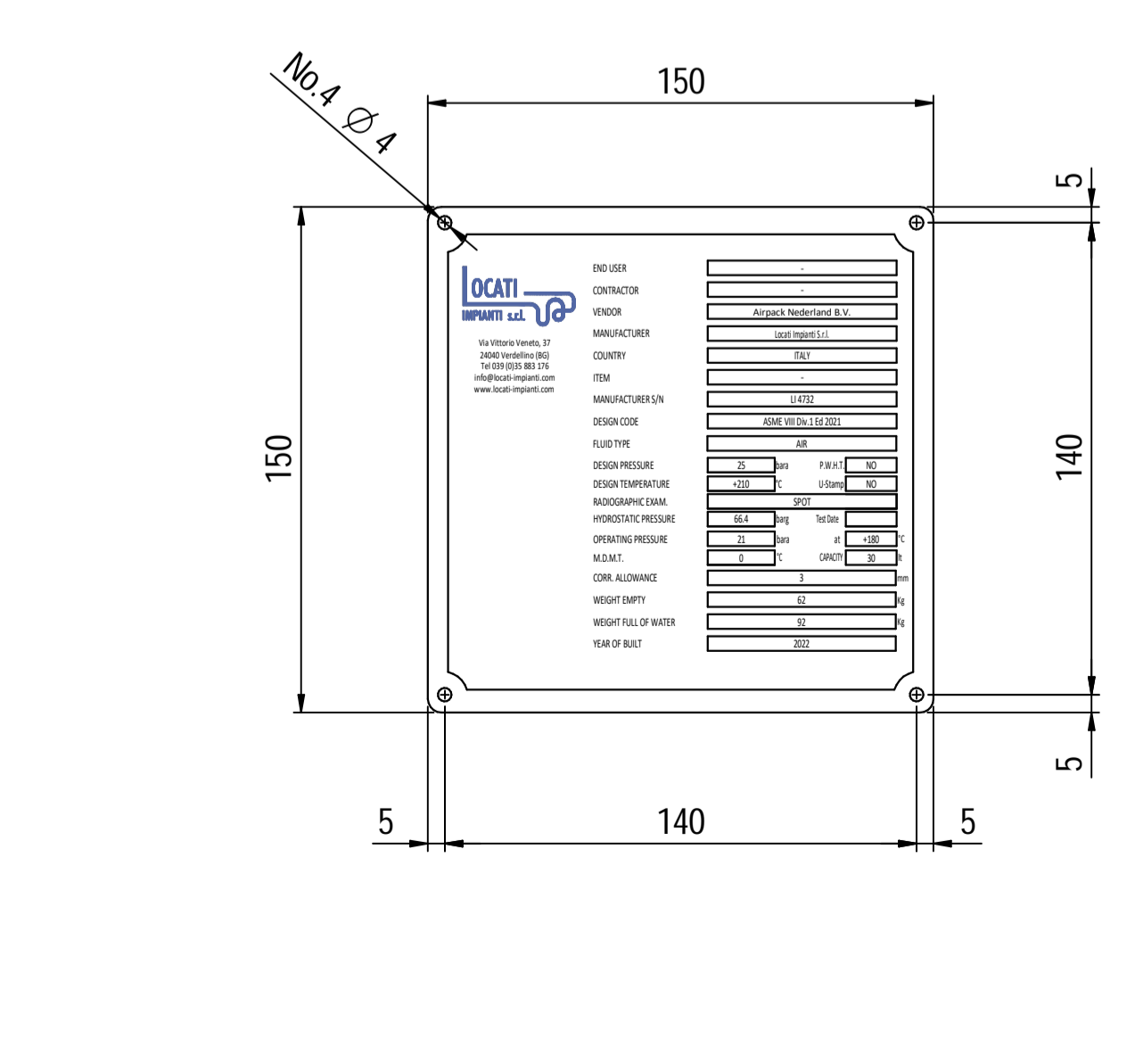

Material List				
Pos.	Q.ty	Description	Mat.	Cert.
1	1	Shell by seamless pipe 8" Sch.40 L=760	SA106 Gr.B	3.1
2	2	Cap 8" Sch40	A234 WPB	3.1
3	2	Flange 2" WN #300 RF Sch.160	A105	3.1
4	1	Seamless pipe 2" Sch160 L=88.5	A106 GrB	3.1
5	1	Seamless pipe 2" Sch160 L=74	A106 GrB	3.1
6	1	Seamless pipe 2" Sch160 L=63	A106 GrB	3.1
7	2	Pad by pipe 8" Sch.40	A106 Gr.B	3.1
8	1	Seamless elbow 2" 90° LR Sch.160	SA 234 WPB	3.1
9	1	Coupling 1/2" NPT #6000	A105	3.1
10	2	Plate 83x231 Thk.8	A516 70	3.1
11	2	Plate 60x140 Thk.10	A516 70	3.1
12	1	Nameplate support 156x241 Thk.3mm	A516 70	3.1
13	2	Earthing Plate 55 x 40 Thk.3	A240 TP316L	

Note:
 1) Governing measurement S.I. unless otherwise specified;
 2) Flange bolt holes have to be straddled from main vessel center line in plan & vertical & horizontal centreline in elevation;
 3) Material: certification 3.1 EN 10204;
 4) All internal edge shall be rounded off;
 5) Nozzle fittings in accordance with ASME B16.5: 2013;
 6) Flange fittings in accordance with ASME B16.9: 2012;
 7) The flange dimensions are in accordance with ASME B16.5: 2013;
 8) All fillet welds not detailed on "WELDING MAP" or drawing shall have the weld; throated equal to 0,7 times the minimum thickness to be welded;
 9) All welds are continuous except where indicate;
 10) See document C220006CLC008 for vessel calculation.

ITEM	QTY	SERVICE	SIZE	O.D.	THK	RATING	TYPE	FACE	O.D.	THK.	Tc
N3	1	DRAIN	1/2"	38.1	8.38	#6000	-	NPT-F	-	-	8.5 ± 10
N2	1	AIR OUTLET	2"	60.3	8.74	#300	WN	RF	-	-	8.5 ± 10
N1	1	AIR INLET	2"	60.3	8.74	#300	WN	RF	-	-	8.5 ± 10

DATI DI PROGETTO / Design data			
FLUIDO	Air	COLLAUDO	Test
STATO FISICO DEL FLUIDO	Gas	NATIONAL BOARD REGISTRATION	Lloyd register
STATO FISICO DEL FLUIDO	Gas	NATIONAL BOARD REGISTRATION	NO
CODICE DI CALCOLO	ASME VIII Div. 1 Ed.2021	CANADIAN REGISTER NUMBER	NO
PRESSIONE DI ESERCIZIO	21 bara	SERVIZIO LETALE	NO
PRESSIONE DI PROGETTO	(25 bara (24 barg))	X-RAY	RT examination
PRESSIONE ESTERNA	NO	LICUIDI PENETRANTI	NO
PRESSIONE DI PROVA IDRAULICA	66.4 barg	Dye penetrant extension	NO
TEMPERATURA DI ESERCIZIO	+180°C	ULTRASUONI	NO
TEMPERATURA DI PROGETTO	+210°C	Ultrasonic extension	NO
SOVRAME TALLO DI CORROSIONE	3 mm	CONTROLLO MAGNETOSCOPICO	NO
CAPACITA'	30 l	Magnetic particle examination	NO
EFFICIENZA GIUNTI	0.85	TALLORE DI SALDATURA	NO
MAWP @ Design Temperature	38.66 barg @ +210°C	PROCEDIMENTO DI SALDATURA	See doc: C220006WBK013
MAWP(EXT)	NO	Welding procedure	
MDMT @ MAWP	0 °C @ 38.66 barg	TIPO DI FONDO	CAP
TRATTAMENTO TERMICO	NO	Head type	
IMPACT TEST	NO	FORMAZIONE FONDO	HOT
		Head formid	
		Joint efficiency	
		PESO A VUOTO	63 kg
		PESO IN ESERCIZIO	63 kg
		PESO PIENO D'ACQUA	92 kg
		Full water weight	
		DATI DEL VENTO	
		Wind datas	
		DATI SISMICI	
		Seismological datas	

Rev.	Descrizione / Description	Disegnato/Draw	Controllato/Checked	Approvato/Approved	Data/Date
04	Modified as per Client comments	CM	MV	GL	11/05/2022
03	Modified as per Client comments	CM	MV	GL	15/04/2022
02	Modified as per Customer comments	CM	MV	GL	02/04/2022
01	Modified earthing lug	CM	MV	GL	25/03/2022
00	FIRST ISSUE	CM	MV	GL	16/03/2022

Oggetto/Object: PULSATION DAMPER OUTLET

Scala/Scale: 1:5
 Comm. N°/Job No.: C220006
 Cliente/Customer: Airpack Nederland B.V.
 Ord. No.: 18498-VV-0901
 Dis. N°/Dwg No.: C220006DWG002
 Rev. 04

LOCATI IMPIANTI s.r.l.