







OWNER:  شرکت سست و سویی توهمه ایران (سهامی خاص)	BUSHEHR PETROCHEMICAL COMPANY MEG PLANT							EPC CONTRACTOR:  Chagalesh-Enerchimi-Steam Joint Venture BUPC-MEG PLANT PROJECT	
	INSTRUMENT HOOK UP DRAWING FOR EMERGENCY INSTRUMENT AIR COMPRESSOR								
MC :  شرکت سست و سویی توهمه ایران (سهامی خاص)	Project	Area	Phase	Unit	Dis.	Doc.	Seq.	Contract No : 52-98/445	
Owner Document Number: 17811-38B	BU	20	VD	303	IN	DWG	0103	Rev.:	Page
								03	1 of 14

## INSTRUMENT HOOK UP DRAWING FOR EMERGENCY INSTRUMENT AIR COMPRESSOR

 شرکت سست و سویی توهمه ایران (سهامی خاص)	 Chagalesh-Enerchimi-Steam Joint Venture BUPC-MEG PLANT PROJECT	BUSHEHR PETROCHEMICAL COMPANY MEG PLANT
<b>Document Review</b>		
Issue Purpose:	AFC	
Result Code: AP,AN,CM,RE,NC	AP	
Next Status : IFC,IFA,IFI,AFC,AB	-	
Responsible Department	MECHANICAL	
Commented Date	6/8/2022	
<b>Approval or review hereunder shall not be construed to relieve Vendor / Subcontractor of his responsibilities and liability under the contract.</b>		

03	17/05/2022	Approved for Construction	AZ	KP	LdM	
02	06/04/2022	For approval	WZ	KP	LdM	
01	14/02/2022	For approval	WZ	KP	LdM	
00	16/11/2021	For approval	WZ	KP	LdM	
Rev.	Date	Purpose of Issue	Prepared	Checked	Approved	AC Code
					Class: 1	Phase: P



BILL OF MATERIALS			
ITEM NO:	DESCRIPTION	MATERIAL	Q'TY
1	PRESSURE DIFFERENTIAL GAUGE	SS316	1
2	PROCESS CONNECTION 1/2" NPT-F	SS316	2
3	CONNECTOR DOUBLE COMPRESSION TYPE 1/4" NPT-M - 1/4" OD	SS316	4
4	TUBING 1/4" OD	SS316	-
5	2-WAY BALL VALVE 1/2" NPT-F	SS316	2
6	5-WAY BLOCK & BLEED MANIFOLD	SS316	1
7	CONNECTOR DOUBLE COMPRESSION TYPE 1/2" NPT-M - 1/2" OD	SS316	8
8	TUBING 1/2" OD	SS316	-
9	TUBING 1/4" OD WITH CAP	SS316	-
10	CONNECTOR DOUBLE COMPRESSION TYPE 1/2" NPT-M - 1/4" OD	SS316	2

TAG NO: PDG-71101

NO. OF INSTALLATIONS: 1

## PRESSURE DIFFERENTIAL GAUGE

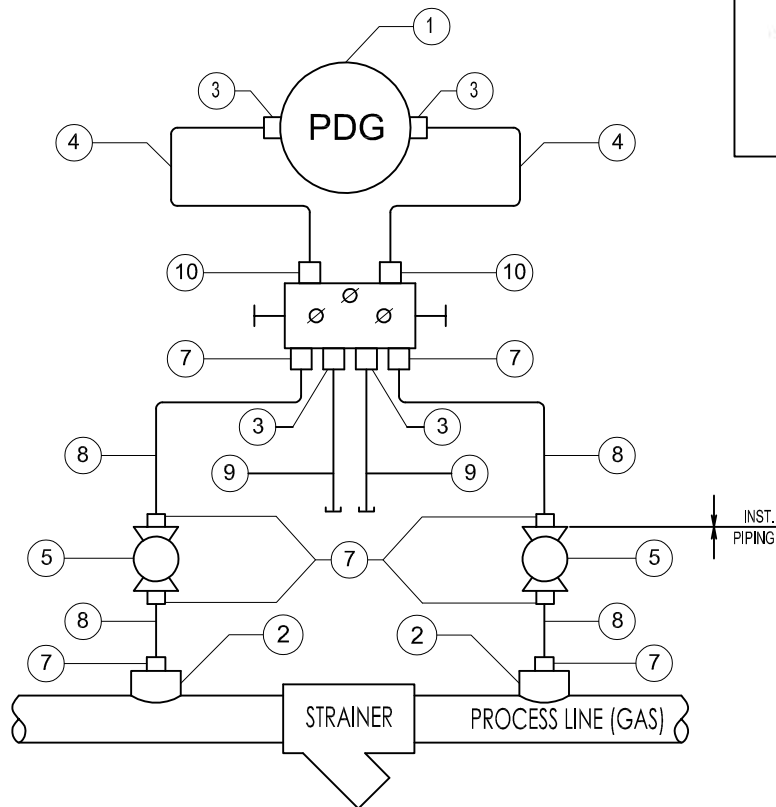

Nozzle Tap (GAS)

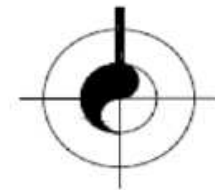

	SUBJECT		INSTRUMENT HOOK UP DRAWING FOR EMERGENCY INSTRUMENT AIR COMPRESSOR	DATE	15-11-2021	THIS DRAWING IS OWNED BY AIRPACK AND SHALL NOT BE PRINTED OR COPIED IN ANY OTHER WAY THAN WITH AIRPACKS PERMISSION			
	CLIENT		Bushehr Petrochemical Company (BUPC)	DRAWN BY	VZ		02	15-04-2022	VZ
	CLIENT REF		17811	CHECKED BY	KP		01	11-02-2022	VZ
	AIRPACK REF		17811-COM	PLANT LOCATION	IRAN, ONSHORE		00	15-11-2021	VZ
			SCALE	-					
			DRAWING NO.	17811-38	MODIFICATIONS		SHEET	01/12	

BILL OF MATERIALS				
ITEM NO:	DESCRIPTION	MATERIAL	Q'TY	
1	PRESSURE GAUGE	SS316	1	
2	PROCESS CONNECTION 1/2" NPT-F	SS316	1	
3	CONNECTOR DOUBLE COMPRESSION TYPE 1/2" NPT-M - 1/2" OD	SS316	6	
4	TUBING 1/2" OD	SS316	-	
5	2-WAY BALL VALVE 1/2" NPT-F	SS316	1	
6	2-WAY BLOCK & BLEED MANIFOLD	SS316	1	
7	CONNECTOR DOUBLE COMPRESSION TYPE 1/4" NPT-F - 1/4" OD	SS316	1	
8	TUBING 1/4" OD WITH CAP	SS316	-	

TAG NO: PG-71102 / PG-71105

NO. OF INSTALLATIONS: 2

### PRESSURE GAUGE

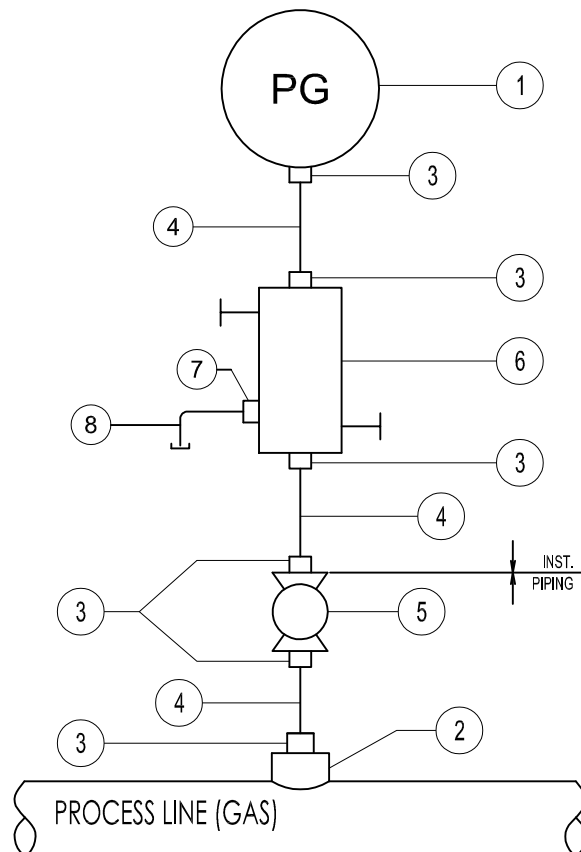

Nozzle Tap (GAS)

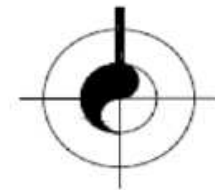

	SUBJECT		INSTRUMENT HOOK UP DRAWING FOR EMERGENCY INSTRUMENT AIR COMPRESSOR	DATE	15-11-2021	THIS DRAWING IS OWNED BY AIRPACK AND SHALL NOT BE PRINTED OR COPIED IN ANY OTHER WAY THAN WITH AIRPACKS PERMISSION			
	CLIENT		Bushehr Petrochemical Company (BUPC)	DRAWN BY	WZ		02	15-04-2022	VZ
	CLIENT REF		17811	CHECKED BY	KP		01	11-02-2022	VZ
	AIRPACK REF		17811-COM	PLANT LOCATION	IRAN, ONSHORE		00	15-11-2021	VZ
			SCALE	-					
			DRAWING NO.	17811-38	MODIFICATIONS		SHEET	02/12	





BILL OF MATERIALS				
ITEM NO:	DESCRIPTION	MATERIAL	Q'TY	
1	TEMPERATURE GAUGE	SS316	1	
2	PROCESS CONNECTION 1 1/2" ANSI 300# RF	SS316	1	
3	THERMOWELL 1 1/2" ANSI 300# RF	SS316	1	
4	CONNECTOR DOUBLE COMPRESSION FITTING 1/2" NPT-M - 6 MM OD	SS316	1	
5	CAPILARY, L=5M MOULDED TO TEMPERATURE ELEMENT	SS316	1	

TAG NO: TG-71103 / TG-71104

NO. OF INSTALLATIONS: 2

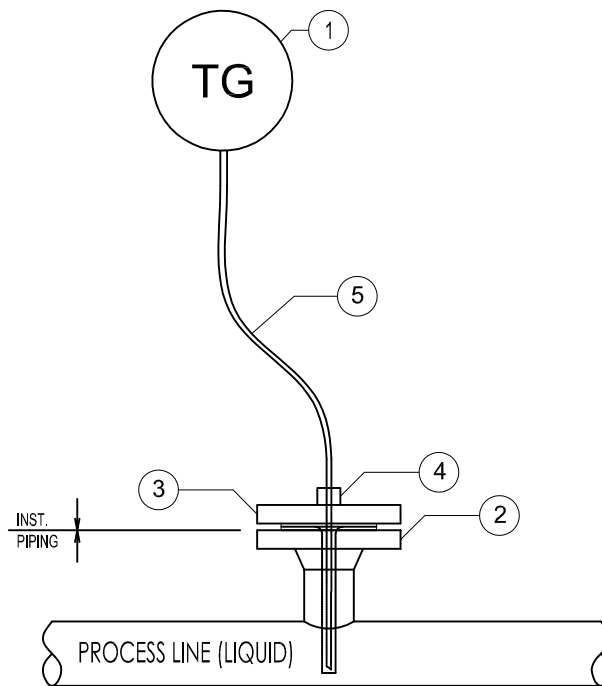
### TEMPERATURE GAUGE



	SUBJECT		INSTRUMENT HOOK UP DRAWING FOR EMERGENCY INSTRUMENT AIR COMPRESSOR	DATE	15-11-2021	THIS DRAWING IS OWNED BY AIRPACK AND SHALL NOT BE PRINTED OR COPIED IN ANY OTHER WAY THAN WITH AIRPACKS PERMISSION			
	CLIENT		Bushehr Petrochemical Company (BUPC)	DRAWN BY	WZ		02	15-04-2022	VZ
	CLIENT REF		17811	CHECKED BY	KP		01	11-02-2022	VZ
	AIRPACK REF		17811-COM	PLANT LOCATION	IRAN, ONSHORE		00	15-11-2021	VZ
				SCALE	-		MODIFICATIONS		SHEET

BILL OF MATERIALS				
ITEM NO:	DESCRIPTION	MATERIAL	Q'TY	
1	PRESSURE TRANSMITTER	ALUMINIUM	1	
2	PROCESS CONNECTION 1/2" NPT-F	SS316	1	
3	CONNECTOR DOUBLE COMPRESSION TYPE 1/2" NPT-M - 1/2" OD	SS316	6	
4	TUBING 1/2" OD	SS316	-	
5	2-WAY BALL VALVE 1/2" NPT-F	SS316	1	
6	2-WAY BLOCK & BLEED MANIFOLD	SS316	1	
7	CONNECTOR DOUBLE COMPRESSION TYPE 1/4" NPT-F - 1/4" OD	SS316	1	
8	TUBING 1/4" OD WITH CAP	SS316	-	

TAG NO: PIT-71103 / PIT-71107

NO. OF INSTALLATIONS: 2

### PRESSURE TRANSMITTER

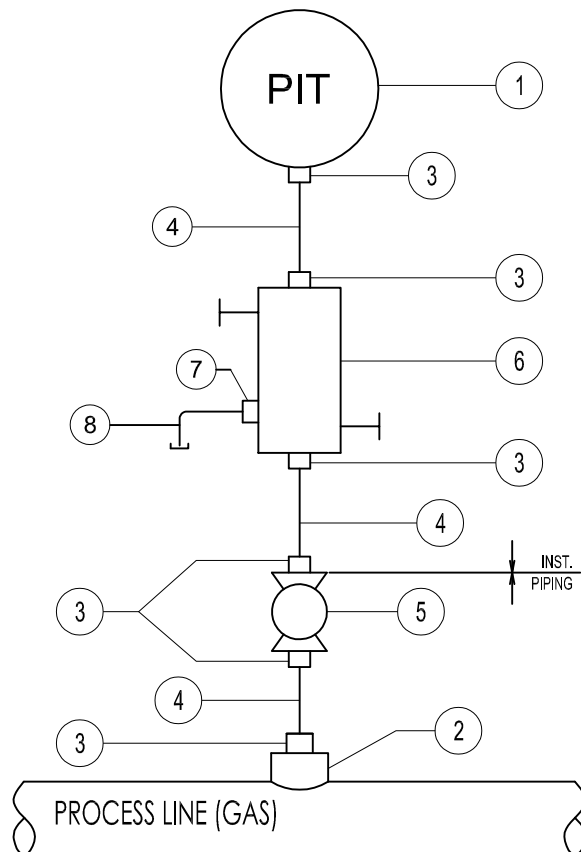

Nozzle Tap (GAS)

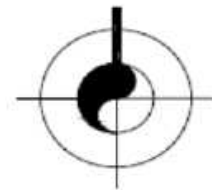

	SUBJECT		INSTRUMENT HOOK UP DRAWING FOR EMERGENCY INSTRUMENT AIR COMPRESSOR	DATE	15-11-2021	THIS DRAWING IS OWNED BY AIRPACK AND SHALL NOT BE PRINTED OR COPIED IN ANY OTHER WAY THAN WITH AIRPACKS PERMISSION			
	CLIENT		Bushehr Petrochemical Company (BUPC)	DRAWN BY	WZ		02	15-04-2022	VZ
	CLIENT REF		17811	CHECKED BY	KP		01	11-02-2022	VZ
	AIRPACK REF		17811-COM	PLANT LOCATION	IRAN, ONSHORE		00	15-11-2021	VZ
			SCALE	-					
			DRAWING NO.	17811-38	MODIFICATIONS		SHEET	05/12	





BILL OF MATERIALS				
ITEM NO:	DESCRIPTION	MATERIAL	Q'TY	
1	TEMPERATURE TRANSMITTER	ALUMINIUM	1	
2	PROCESS CONNECTION 1 1/2" ANSI 300# RF	SS316	1	
3	THERMOWELL 1 1/2" ANSI 300# RF	SS316	1	
4	CONNECTOR DOUBLE COMPRESSION FITTING 1/2" NPT-M - 6 MM OD	SS316	1	
5	CAPILARY, L=5M MOULDED TO TEMPERATURE ELEMENT	SS316	1	

TAG NO: TIT-71101 / TIT-71102

NO. OF INSTALLATIONS: 2

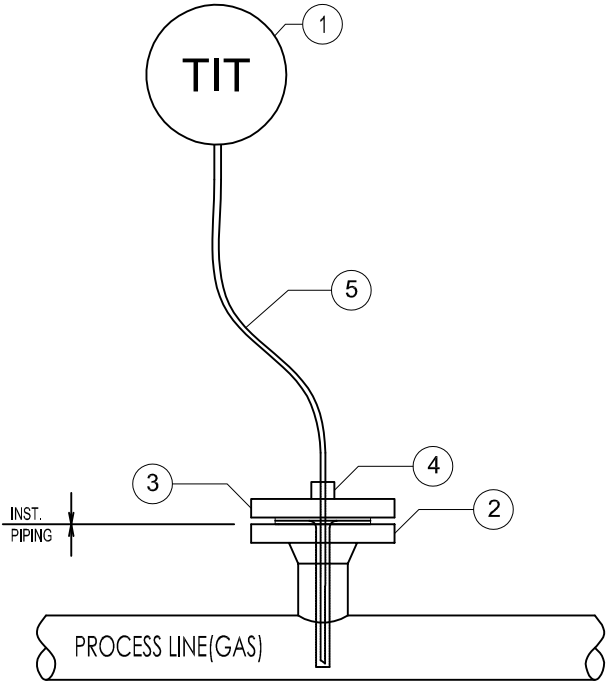
### TEMPERATURE TRANSMITTER



	SUBJECT		INSTRUMENT HOOK UP DRAWING FOR EMERGENCY INSTRUMENT AIR COMPRESSOR	DATE	15-11-2021	THIS DRAWING IS OWNED BY AIRPACK AND SHALL NOT BE PRINTED OR COPIED IN ANY OTHER WAY THAN WITH AIRPACKS PERMISSION			
	CLIENT		Bushehr Petrochemical Company (BUPC)	DRAWN BY	WZ		02	15-04-2022	VZ
	CLIENT REF		17811	CHECKED BY	KP		01	11-02-2022	VZ
	AIRPACK REF		17811-COM	PLANT LOCATION	IRAN, ONSHORE		00	15-11-2021	VZ
				SCALE	-				
			DRAWING NO.	17811-38	MODIFICATIONS	SHEET		07/12	



BILL OF MATERIALS				
ITEM NO:	DESCRIPTION	MATERIAL	Q'TY	
1	3-WAY SOLENOID VALVE	SS 316	1	
2	CONNECTOR DOUBLE COMPRESSION TYPE 1/4" NPT-M - 1/4" OD	SS 316	3	
3	TUBING 1/4" OD	SS 316	-	
4	AIR INLET FILTER/REGULATOR	SS 316	1	

TAG NO: XY-71101

NO. OF INSTALLATIONS: 1

### SOLENOID VALVE

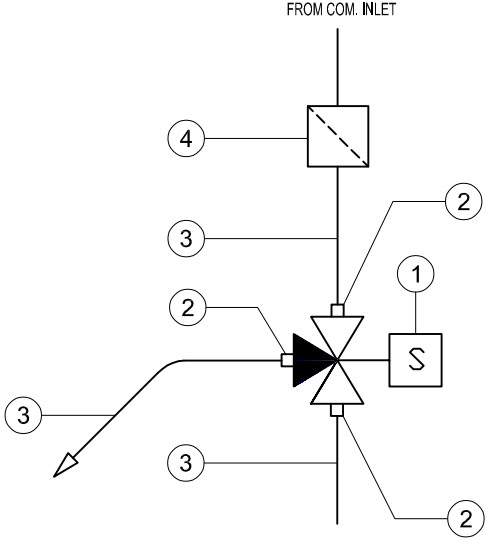

	SUBJECT		INSTRUMENT HOOK UP DRAWING FOR EMERGENCY INSTRUMENT AIR COMPRESSOR	DATE	15-11-2021	THIS DRAWING IS OWNED BY AIRPACK AND SHALL NOT BE PRINTED OR COPIED IN ANY OTHER WAY THAN WITH AIRPACKS PERMISSION			
	CLIENT		Bushehr Petrochemical Company (BUPC)	DRAWN BY	VZ		02	15-04-2022	VZ
	CLIENT REF		17811	CHECKED BY	KP		01	11-02-2022	VZ
	AIRPACK REF		17811-COM	PLANT LOCATION	IRAN, ONSHORE		00	15-11-2021	VZ
				SCALE	-				
			DRAWING NO.	17811-38	MODIFICATIONS	SHEET	09/12		

BILL OF MATERIALS				
ITEM NO:	DESCRIPTION	MATERIAL	Q'TY	
1	2-WAY BALL VALVE 1 1/2" ANSI 150# RF	SS 316	1	
2	CONNECTOR DOUBLE COMPRESSION TYPE 1/4" NPT-M - 1/4" OD	SS 316	6	
3	3-WAY SOLENOID VALVE	SS 316	1	
4	TUBING 1/4" OD	SS 316	-	
5	FILTER REGULATOR	SS316	1	

TAG NO: XV-71102  
XY-71102

NO. OF INSTALLATIONS: 1

### PNEUMATIC OPERATED BALL VALVE

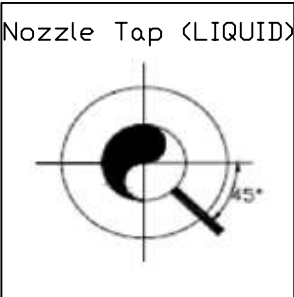
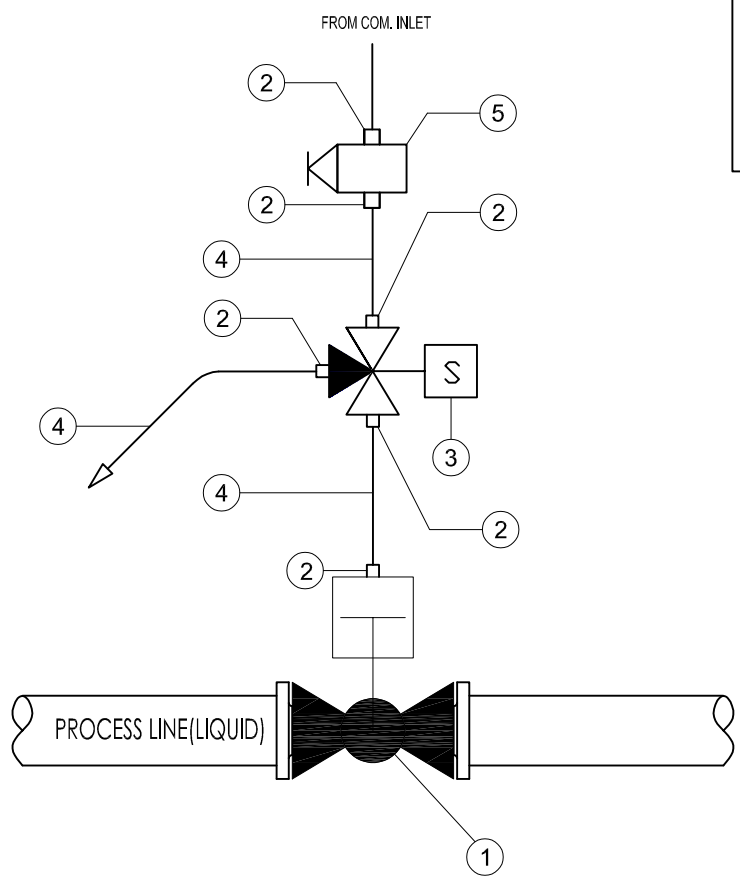

	SUBJECT		INSTRUMENT HOOK UP DRAWING FOR EMERGENCY INSTRUMENT AIR COMPRESSOR	DATE	15-11-2021	THIS DRAWING IS OWNED BY AIRPACK AND SHALL NOT BE PRINTED OR COPIED IN ANY OTHER WAY THAN WITH AIRPACKS PERMISSION			
	CLIENT		Bushehr Petrochemical Company (BUPC)	DRAWN BY	WZ		02	15-04-2022	VZ
	CLIENT REF		17811	CHECKED BY	KP		01	11-02-2022	VZ
	AIRPACK REF		17811-COM	PLANT LOCATION	IRAN, ONSHORE		00	15-11-2021	VZ
	SCALE		-	DRAWING NO.	17811-38		MODIFICATIONS		SHEET

BILL OF MATERIALS				
ITEM NO:	DESCRIPTION	MATERIAL	Q'TY	
1	PRESSURE RECYCLE VALVE 1" ANSI 300# RF	SS316	1	
2	TUBING 1/4" OD	SS316	-	
3	CONNECTOR DOUBLE COMPRESSION TYPE 1/4" NPT-M x 1/4" OD	SS316	3	
4	FILTER REGULATOR	SS316	1	
5	VALVE POSITIONER WITH INLET AND OUTLET GAUGE	SS316	1	

TAG NO: PV-71101

NO. OF INSTALLATIONS: 1

### PRESSURE RECYCLE VALVE

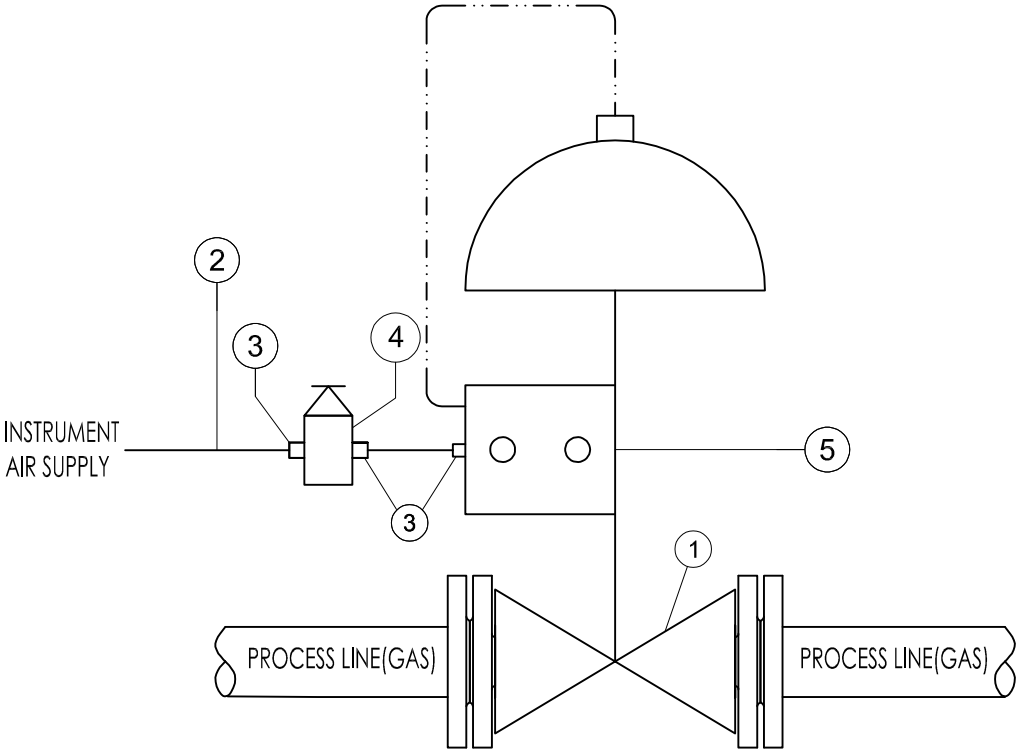

	SUBJECT		INSTRUMENT HOOK UP DRAWING FOR EMERGENCY INSTRUMENT AIR COMPRESSOR		DATE	15-11-2021	THIS DRAWING IS OWNED BY AIRPACK AND SHALL NOT BE PRINTED OR COPIED IN ANY OTHER WAY THAN WITH AIRPACKS PERMISSION			
	CLIENT		Bushehr Petrochemical Company (BUPC)		DRAWN BY	VZ		02	15-04-2022	VZ
	CLIENT REF		17811		CHECKED BY	KP		01	11-02-2022	VZ
	AIRPACK REF		17811-COM		PLANT LOCATION	IRAN, ONSHORE		00	15-11-2021	VZ
				SCALE	-					
				DRAWING NO.	17811-38	MODIFICATIONS		SHEET	11/12	

