







OWNER:  شرکت ست و پتو آوند ايرانيان (سهائي ناهس)	BUSHEHR PETROCHEMICAL COMPANY MEG PLANT						EPC CONTRACTOR:  Chagalesh-Enerchimi-Steam Joint Venture BUPC-MEG PLANT PROJECT		
	COMPRESSOR MOTOR OUTLINE DRAWING & TERMINAL BOX WIRING DIAGRAM FOR EMERGENCY INSTRUMENT AIR COMPRESSOR						 Netherlands		
MC :  شرکت ست و پتو آوند ايرانيان (سهائي ناهس)	Project	Area	Phase	Unit	Dis.	Doc.	Seq.	Contract No: 52-98/445	
Owner Document Number: 17811-39B	BU	20	VD	303	EL	DWG	0101	Rev.:	Page
								04	1 of 5

COMPRESSOR MOTOR OUTLINE DRAWING & TERMINAL BOX WIRING DIAGRAM FOR EMERGENCY INSTRUMENT AIR COMPRESSOR

 شرکت ست و پتو آوند ايرانيان (سهائي ناهس)		 Chagalesh-Enerchimi-Steam Joint Venture BUPC-MEG PLANT PROJECT		BUSHEHR PETROCHEMICAL COMPANY MEG PLANT	
Document Review					
Issue Purpose:			AB		
Result Code: AP,AN,CM,RE,NC			AP		
Next Status : IFC,IFA,IFI,AFC,AB			-		
Responsible Department			MECHANICAL		
Commented Date			Sep/18/2022		
Approval or review hereunder shall not be construed to relieve Vendor / Subcontractor of his responsibilities and liability under the contract.					

04	05/09/2022	As Built	KP	CL	JR	
03	24/01/2022	Approved for Construction	KP	LdM	JR	
02	06/01/2022	For approval	KP	LdM	JR	
01	10/12/2021	For approval	KP	LdM	JR	
00	08/12/2020	For approval	KP	LdM	JR	
Rev.	Date	Purpose of Issue	Prepared	Checked	Approved	AC Code
					Class: 1	Phase: P

Emergency Instrument Air Compressor 20-C-7080-M

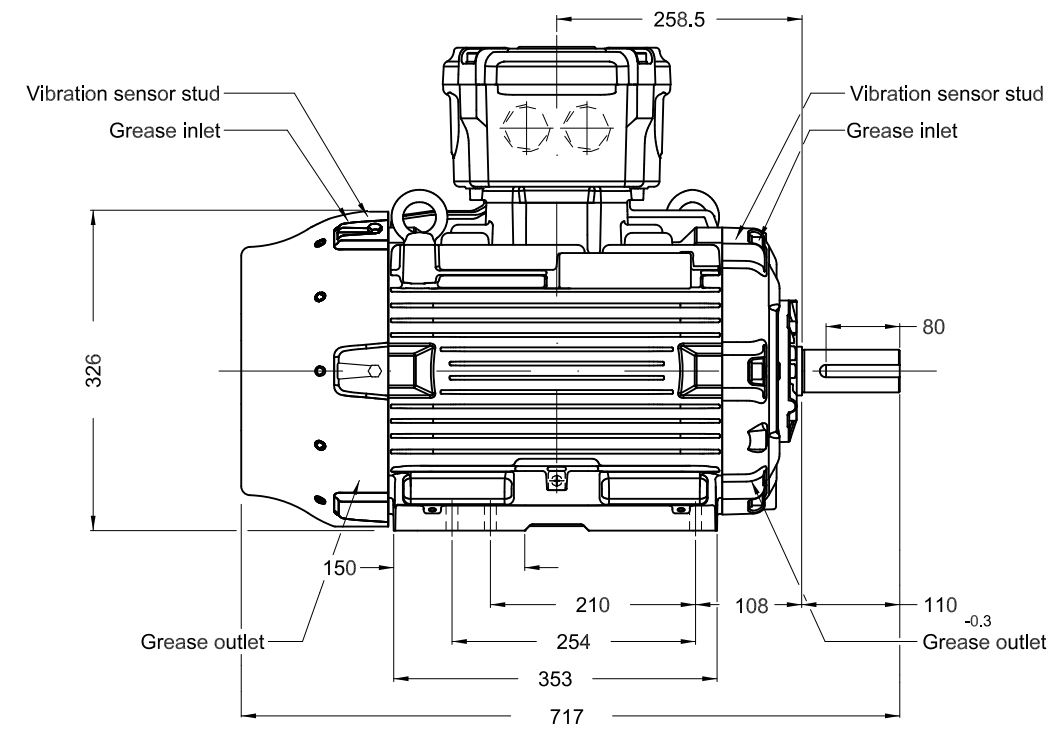
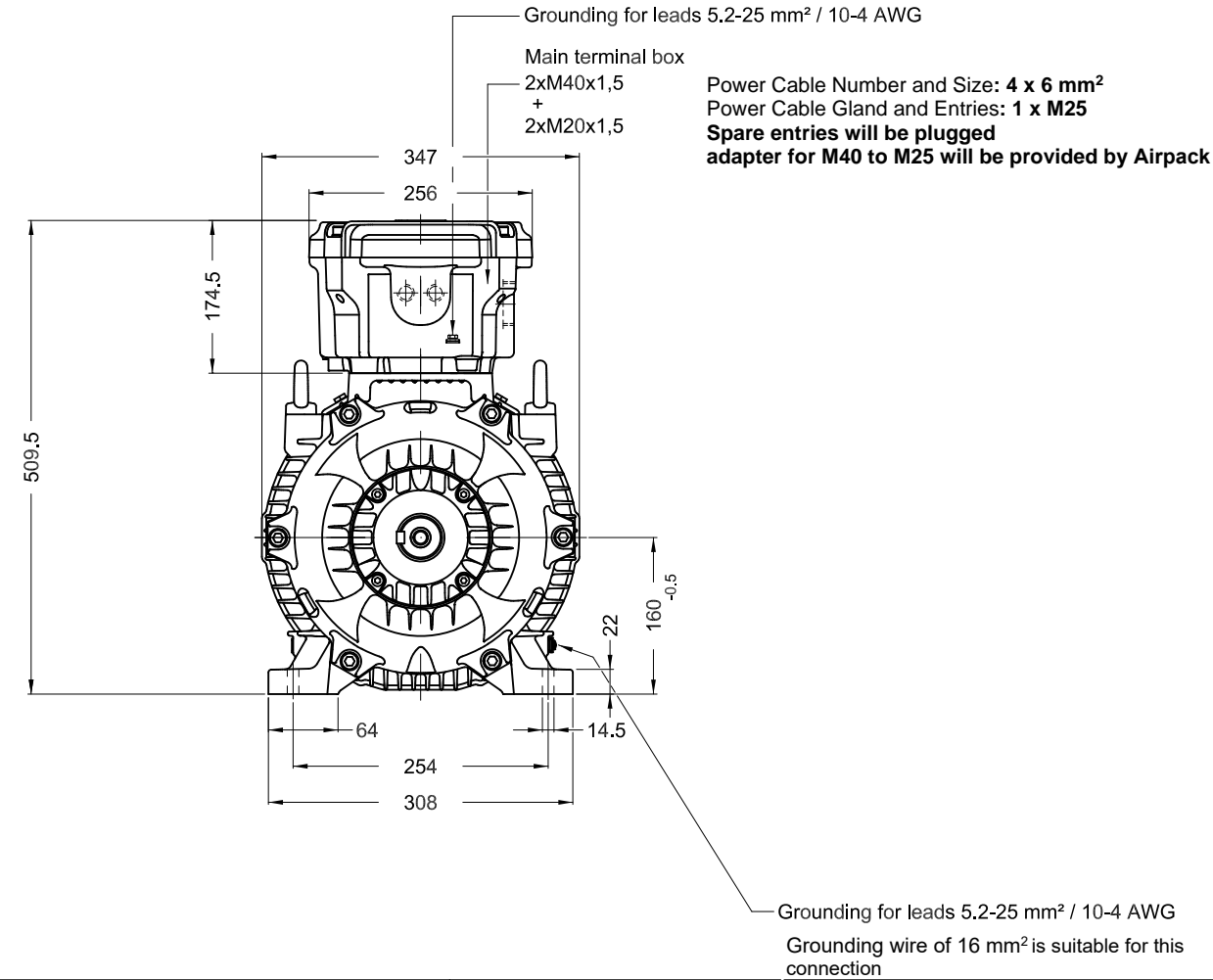

- Tropicalized internal painting
- DE roller bearing
- Shaft locking device
- Shaft material - AISI/SAE 4140
- SPM studs
- Color RAL 5010
- Painting plan 205P
- Mounting B3T

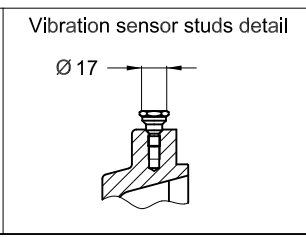
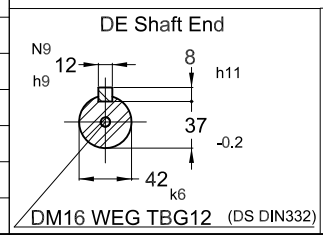

15 kW 04 Poles 50 Hz		AIRPACK B.V.				A			
DOCUMENTO NOVO 419034292		MIRIANEV	WILLIANR	SIMONETTI	06.12.2021	01			
ECM	LOC	SUMMARY OF MODIFICATIONS			EXECUTED	CHECKED	RELEASED	DATE	VER
EXECUTED	PIRWBUSER	THREE PH. MOTOR W22Xdb IE4 Ex d IIB T4	1233471934		WDD	01	03/05	SHEET	03/05
CHECKED	NMAGNO		FRAME 160M/L IP56 TEFC						
RELEASED	NMAGNO	Main Compressor Motor 20-C-7080-M 15kW		WEG					
REL DT.	23.11.2021	WMO	Jaragua do Sul	Product Engineering					

CERTIFIED WEG MOTORES - Certified document. Not subject to changes. Dimensions in mm XME A3

1 2 3 4 5 6

Dimensional drawing subject to change. We reserve the right to change constructional details.
 * Detail out of scale.

A
B
C
D
E

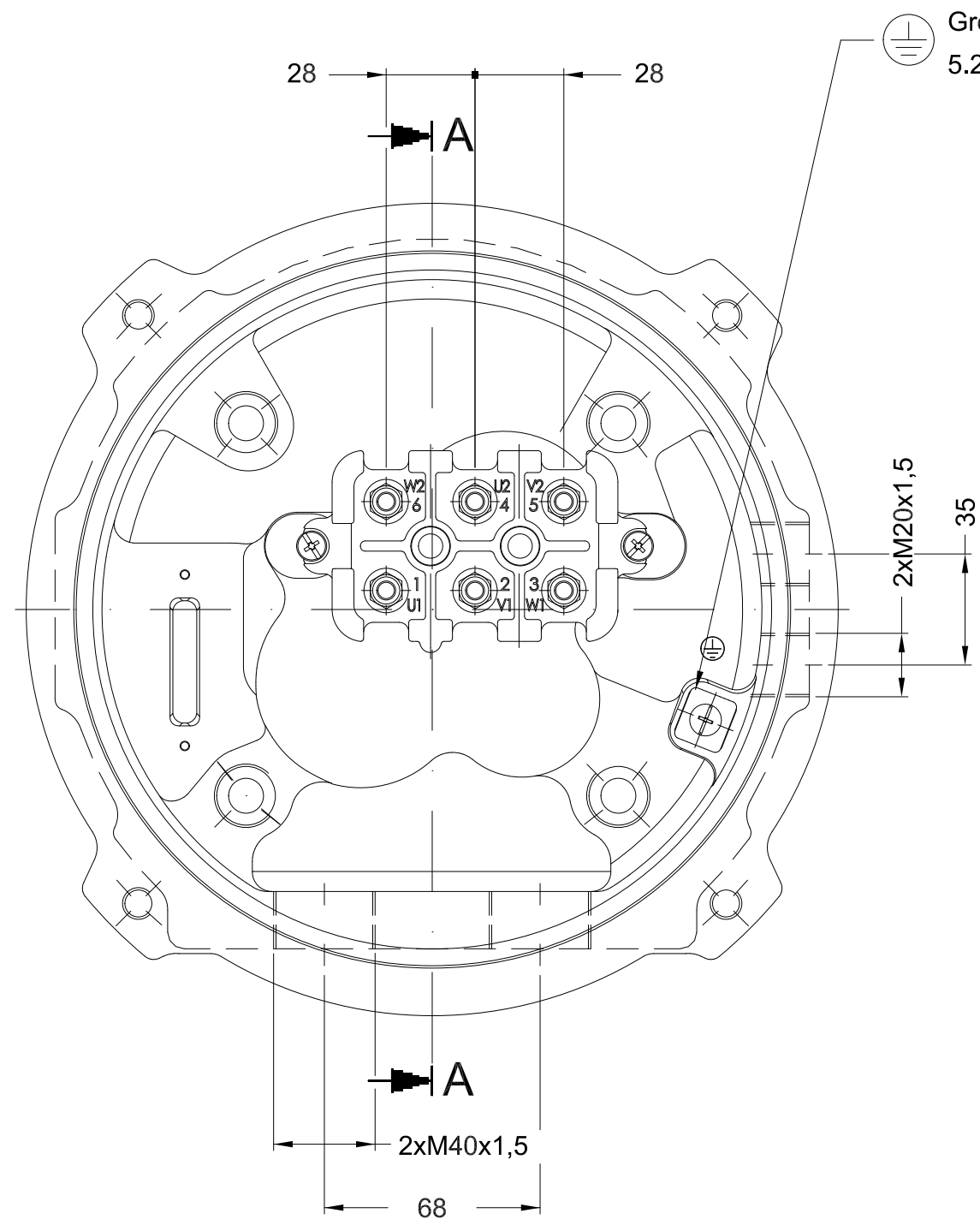

Grounding
 5.2-25mm² / 10-4AWG

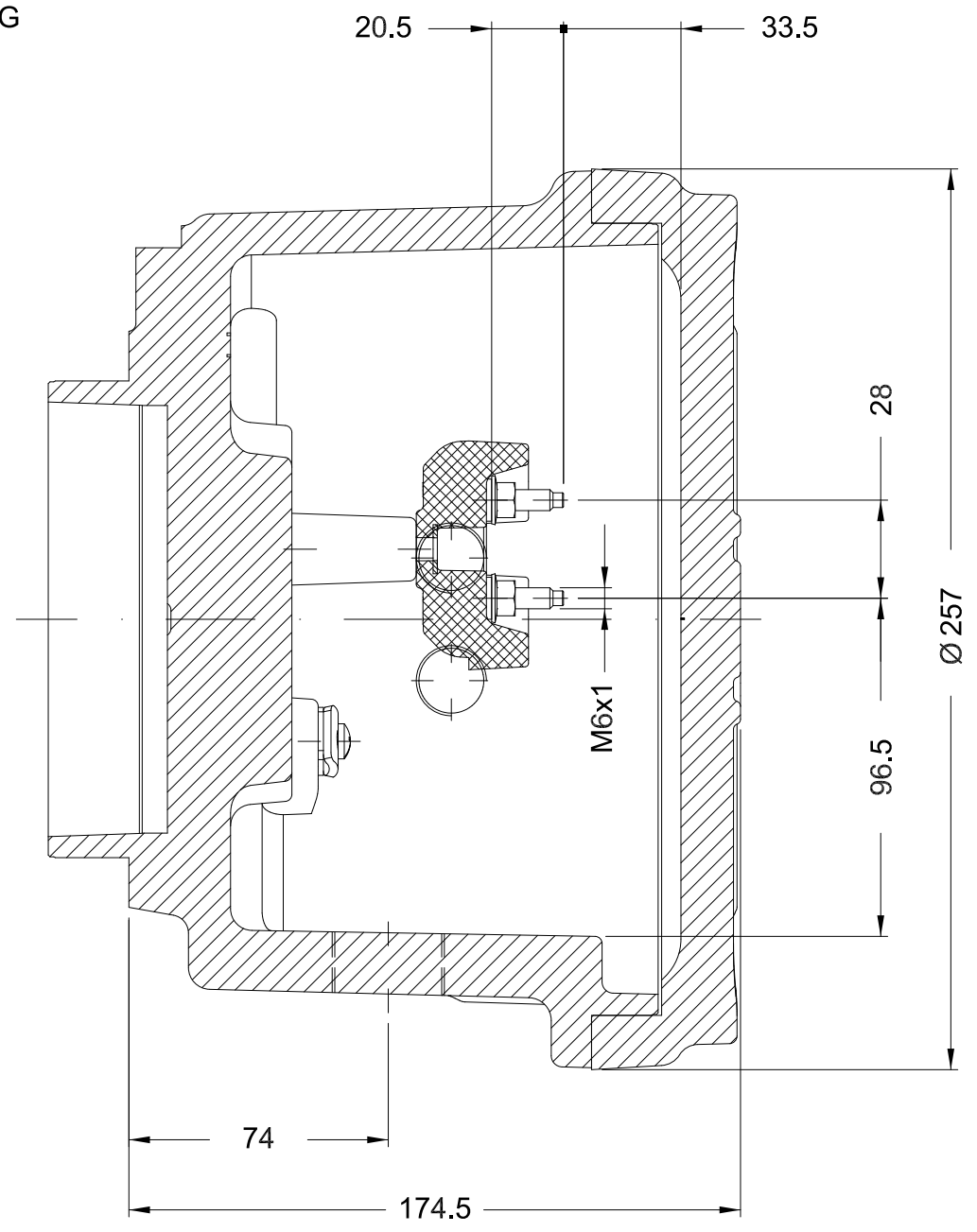

Section A-A

						ESC	1:2		
ECM	LOC	SUMMARY OF MODIFICATIONS			EXECUTED	CHECKED	RELEASED	DATE	VER
EXECUTED	YDAMHUIS	MAIN TERMINAL BOX							
CHECKED		FRAME 160M/L							
RELEASED									
REL DT.									
						PREVIEW			
						WCD SHEET			
						04/05			

THIS IS AN UPDATED REVISION, THE PREVIOUS ONE MUST BE DISREGARDED.

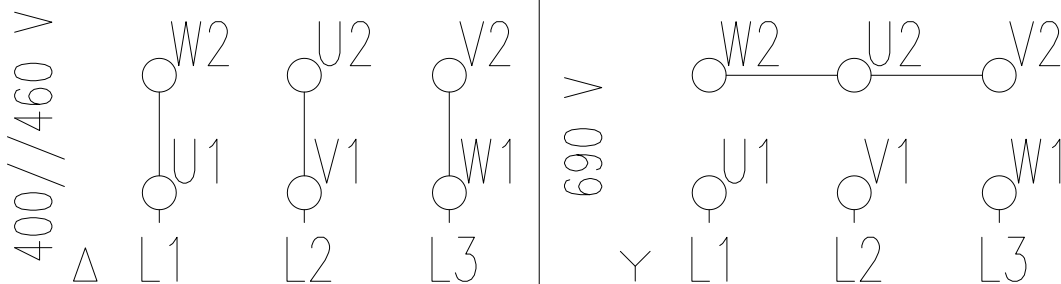

A

B

C

D

E

		ORIGINAL ISSUE		JESSICA	PATRICIA	CASTELLA	30.10.2018	00
ECM	LOC	RESUMO MODIFICAÇÃO SUMMARY OF MODIFICATIONS		EXECUTADO EXECUTED	VERIFICADO CHECKED	LIBERADO RELEASED	DATA DATE	VER VER
EXEC. /EXECUTED	JESSICA		LOW VOLTAGE - CONNECTION DIAGRAM 400/690//460V MOTOR WITH 06 CABLES	400/690//460-6				
VERIF. /CHECKED	PATRICIA			IEC	00			
LIBER. /RELEASED	CASTELLA							
DATA LB /REL DT	30.10.2018	WMO	JARAGUÁ DO SUL	ADMINISTRAÇÃO DE VENDAS	FOLHA /SHEET	05/05		