







<b>OWNER:</b>  شرکت سست و سویی ژوسه ایرانین (سهامی خاص)	<b>BUSHEHR PETROCHEMICAL COMPANY MEG PLANT</b>						<b>EPC CONTRACTOR:</b>  Chagalesh-Enerchimi-Steam Joint Venture BUPC-MEG PLANT PROJECT		
	<b>INSTALLATION, OPERATION AND MAINTENANCE MANUAL</b>							 Netherlands	
<b>MC :</b>  شرکت سست و سویی ژوسه ایرانین (سهامی خاص)	Project	Area	Phase	Unit	Dis.	Doc.	Seq.	Contract No : 52-98/445	
<b>Owner Document Number: 17811-20</b>	BU	20	VD	303	ME	MNL	0012	Rev.:	Page
								01	1 of 342

  Chagalesh-Enerchimi-Steam Joint Venture BUPC-MEG PLANT PROJECT		<b>BUSHEHR PETROCHEMICAL COMPANY MEG PLANT</b>
<b>Document Review</b>		
Issue Purpose:	AFC	
Result Code: AP,AN,CM,RE,NC	AP	
Next Status : IFC,IFA,IFI,AFC,AB	—	
Responsible Department	MECHANICAL	
Commented Date	Nov.25,2024	
<b>Approval or review hereunder shall not be construed to relieve Vendor / Subcontractor of his responsibilities and liability under the contract.</b>		

# INSTALLATION, OPERATION AND MAINTENANCE MANUAL

01	18/11/2024	Approved for Construction	MC	KP	JR	
00	08/11/2024	For approval	MC	KP	JR	
<b>Rev.</b>	<b>Date</b>	<b>Purpose of Issue</b>	<b>Prepared</b>	<b>Checked</b>	<b>Approved</b>	<b>AC Code</b>
					<b>Class: 1</b>	<b>Phase: P</b>





المملكة العربية السعودية  
الجمهورية العربية السورية



# BUSHEHR PETROCHEMICAL COMPANY



## VENDOR DATA BOOK INDEX

### Part 2 - Operating and Maintenance Data

#	Document No.	Document Title	Rev. No.	Hyper Link
1	BU-20-VD-303-ME-MNL-0012	Installation, operation & maintenance manual	00	
1.1	1	Safety precautions	00	
1.2	2	Nitrogen gas booster compressor	00	
1.3	3	Emergency instrument air compressor	00	
1.4	4	Main motor	00	
1.5	5	Inter / After cooler	00	
1.6	6	Differential pressure gauge	00	
1.7	7	Pressure gauge	00	
1.8	8	Temperature gauge	00	
1.9	9	Thermowell	00	
1.10	10	Pressure transmitter	00	
1.11	11	Temperature transmitter	00	
1.12	12	Flow transmitter	00	
1.13	13	Vibration transmitter	00	
1.14	14	Solenoid valve	00	
1.15	15	Y-strainer	00	
1.16	16	Hand ball valve	00	
1.17	17	Pneumatic actuated valve	00	
1.18	18	Hand globe valve	00	
1.19	19	Pressure reducing valve	00	
1.20	20	Pressure control valve	00	
1.21	21	Check valve	00	
1.22	22	Overall spare parts list with cross sectional drawings	00	
1.23	23	Troubleshooting	00	
1.24	24	Preventive maintenance chart	00	
1.25	25	Logbook	00	
1.26	26	Plant manager liability list	00	
1.27				
1.28				

# Bushehr MEG Plant Project

<b>VENDOR NAME</b>	: Airpack Nederland B.V
<b>EQUIPMENT DESCRIPTION</b>	: Nitrogen & Instrument Booster Package
<b>EQUIPMENT TAGNUMBER</b>	: 20-C-1002, 20-C-7080

## SECTION 1

### SAFETY PRECAUTIONS



**Vendor doc. Number**

17811-20

**Vendor:**

Airpack Nederland B.V.

**P.O. NO.:**

MEG20-PO-BP303-021

**SHEET QTY: 08**



**BUSHEHR MEG PLANT PROJECT**

Safety precautions and reminders at site

Rev.: 00  
Date: 08-11-2024

The warranties agreed for this equipment are exclusive and all other warranties, whether express, oral, implied or otherwise, including but not limited to the implied warranties of merchantability and fitness for a particular purpose, are hereby expressly disclaimed. Correction of nonconformities within the applicable warranty period set forth above provides the exclusive remedies with respect to the quality of or any defect in products or services delivered or performed hereunder. Notwithstanding anything else, the total liability, in the aggregate, of seller, its affiliates, and subcontractors, and their respective employees and agents shall be limited to the price paid by the purchaser to seller for the specific product/service giving rise to the claim. Under no circumstances shall seller, its affiliates, or subcontractors, or their respective employees or agents be liable for any consequential, incidental, indirect, special or punitive damages (whether for lost profits or revenue, work stoppage, downtime costs, lost business, or otherwise), even if advised of the possibility of such damages or if such damages are foreseeable.

This equipment is designed as per agreed specifications and recommendations of Airpack Nederland B.V and is delivered 'as is'. Technical recommendations waived by the buyer and their consequences are excluded from warranty. A warranty period has been agreed in the contract and is only valid as long as:

- The product is operated at agreed design considerations;
- The product is operated and maintained as described in the operating manual supplied by Airpack Nederland BV;
- The owner uses genuine Airpack Nederland BV parts and consumables.

The warranty is limited to defects resulting from faulty design, materials, and workmanship only. Normal wear and tear, misuse and improper fitting are excluded from this warranty.

If, during any warranty period the user:

- (a) makes any design change to the equipment without prior consent of Airpack Nederland BV or;
- (b) uses replacement parts other than those supplied or approved in writing by Airpack Nederland BV; or
- (c) carries out any repairs or replacements using unqualified staff;

This warranty shall, on the happening of any such event, immediately be rendered null and void.

All decisions relating to warranty work made by Airpack Nederland BV will be binding and final.

Please be aware that disregarding instructions in the operating manual, using non-genuine spare parts and making unauthorized modifications, may result in serious damage to the machine, your environment, and yourself!

All parts purchased that are claimed to be defective must be returned at the customer's risk and freight paid to Airpack headquarters.

This warranty does not cover consequential damages resulting from failure of parts or equipment or subsequent expenses or losses. This warranty is extended only to the first user of

	<b>BUSHEHR MEG PLANT PROJECT</b>	Rev.: 00
	Safety precautions and reminders at site	Date: 08-11-2024

the equipment purchased from Airpack Nederland BV and may not be transferred to any other person.

## **1 Basic operation and designation use of the machine/plant**

- 1.1 The machine/plant has been built in accordance with state-of-the-art standard and the recognized safety rules. Nevertheless, its use may constitute a risk to life and limb of the user or third parties, or cause damage to the machine and to other material property.
- 1.2 The machine / plant must only be used in technically perfect condition in accordance with its designated use and the instructions set out in the operating manual, and only by safety-conscious persons who are fully aware of the risks involved in operating the machine/plant. Any functional disorders, especially those affecting the safety of the machine/plant, should therefore be rectified immediately.
- 1.3 The machine/plant is designed exclusively for the compression of the medium (air/gas) specified under "Technical data" of the operating instructions manual considered contrary to its designation use. The manufacturer/supplier cannot be held liable for any damage resulting from such use. The risk of such misuse lies entirely with the user. Operating the machine within the limits of its designation use also involves observing the instructions set out in the operating manual and complying with the inspection and maintenance directives.

## **2 Organizational measures**

- 2.1 The operating instructions must always be at hand at the place of use of the machine/plant, e.g. by stowing them in the tool compartment or tool-box provided for such purpose.
- 2.2 In addition to the operating instructions, observe and instruct the user in all other generally applicable legal and other mandatory regulations relevant to accident prevention and environmental protection.  
  
These compulsory regulations may also deal with the handling of hazardous substances, issuing and/or wearing of personal protective equipment.
- 2.3 The operating instructions must be supplemented by instructions covering the duties involved in supervising and notifying special organizational features, such as job organisation, working sequences or the personnel protective equipment.
- 2.4 Personnel entrusted with work on the machine must have read the operating instructions and in particular the chapter on safety before beginning work. Reading the instructions after work has begun is too late. This applies especially to persons working only occasionally on the machine, e.g. during maintenance.
- 2.5 Check at least from time to time whether the personnel is carrying out the work in compliance with the operating instructions and paying attention to risks and safety factors.

- 2.6 For reasons of security, long hair must be tied back or otherwise secured, garments must be close-fitting and no jewellery –such as rings- may be worn. Injury may result from being caught up in the machinery or from rings catching on moving parts.
- 2.7 Use protective equipment wherever required by the circumstances or by law.
- 2.8 Observe all safety instructions and warnings.
- 2.9 See to it that safety instructions and warnings attached to the machine are always complete and perfectly legible.
- 2.10 In event of safety-relevant modifications or changes in the behaviour of the machine/plant during operation, stop the machine / plant immediately and report the malfunction to the competent authority/person.
- 2.11 Never make any modifications, additions or conversions which might affect safety without the supplier approval. This also applies to the installation and adjustment of safety devices and valves as well as to welding work on pipe lines and receivers.
- 2.12 Spare parts must comply with the technical requirements specified by the manufacturer. Spare parts from original equipment manufacturers can be relied to do so.
- 2.13 Never modify the software of programmable control systems.
- 2.14 Hose pipes are subject to a quality check (pressure and visual examination) by the operator in appropriate intervals even if no safety-relevant defects have been detected.
- 2.15 Adhere to prescribed intervals or those specified in the operating instructions for routine checks and inspections.
- 2.16 For execution of maintenance work, tools and workshop equipment adapted to the task on hand are absolutely indispensable.
- 2.17 The personnel must be familiar with the location and operation of the fire exiting users.
- 2.18 Observe all fire-warning and fire-fighting procedures.

### **3 Selection and qualification of personnel – basic responsibilities**

- 3.1 Any work on and with the machine/plant must be executed by reliable personnel only. Statutory minimum age limits must be observed.
- 3.2 Employ only trained or instructed staff and set out clearly the individual responsibilities of the personnel for operation, maintenance and repair.
- 3.3 Make sure that only authorised personnel works on or with the machine.
- 3.4 Define the machine operator's responsibilities given the operator the authority to refuse instructions by third parties that are contrary to safety.

- 3.5 Do not allow persons to be trained or instructed or persons taking part in a general training course to work on or with the machine / plant without being permanently supervised by an experienced person.
- 3.6 Work on the electrical system and equipment of the machine / plant must be carried out only by a skilled electrician or by instructed persons under the supervision and guidance of a skilled electrician and in accordance with the electrical engineering rules and regulations.
- 3.7 Work on gas-fuelled equipment (gas consumers) may be carried out by specially trained personnel only.

#### **4 Safety instructions governing specific operational phases**

##### **4.1 Standard operation**

- 4.1.1 Avoid any operational mode that might be prejudicial to safety.
- 4.1.2 Take the necessary precautions to ensure the machine is used only when in a safe and reliable state. Operate the machine only if all protective and safety-oriented devices, such as removable safety devices, emergency shut-off equipment and sound-proofing elements are in place and fully functional.
- 4.1.3 Check the machine at least once per working shift for obvious damage and defects. Report any changes (incl. changes in the machine's working behavior) to the competent organization / person immediately. If necessary, stop the machine immediately and lock it.
- 4.1.4 In the event of malfunctions, stop the machine immediately and lock it. Have any defects rectified immediately.
- 4.1.5 During start up or setting the machine in motion, make sure that nobody is at risk.

##### **4.2 Special work in conjunction with utilization of the machine and maintenance and repairs during operation; disposal of parts and consumables.**

- 4.2.1 Observe the adjusting, maintenance and inspection activities and intervals set out in the operating instructions, including information on the replacement of parts and equipment. These activities may be executed by skilled personnel only.
- 4.2.2 Brief operating personnel before beginning special operations and maintenance work, and appoint a person to supervise the activities.
- 4.2.3 In any work concerning the operation, conversion or adjustment of the machine and its safety – oriented devices or any work relate to maintenance, inspection and repair, always observe that start-up and shut-down procedure set out in the operating instructions and the information on maintenance work.
- 4.2.4 Ensure that the machine area is adequately secured.

- 4.2.5 If the machine/plant is completely shut down for maintenance and repair work, it must be secured against inadvertent starting by
- locking the principal control elements and
  - attaching a warning sign to the main switch
- 4.2.6 To avoid the risk of accidents, individual parts and large assemblies being moved for replacement purposes should be carefully attached to lifting tackle and secured. Use only suitable and technically perfect lifting gear and suspension systems with adequate lifting capacity. Never work or stand under suspended loads.
- 4.2.7 The fastening of loads and the instruction of crane operators should be entrusted to experienced persons only. The marshaller giving the instructions must be within sight or sound of the operator.
- 4.2.8 For carrying out overhead assembly work always use specially designed or otherwise safety-oriented ladders and working platforms. Never use machine parts as a climbing aid. Wear a safety harness when carrying out maintenance work at greater heights. Keep all handles, steps, handrails, platforms, landing and ladders free from dirt.
- 4.2.9 Clean the machine, especially connections and threaded unions, of any traces of oil, fuel or preservatives before carrying out maintenance / repair. Never use aggressive detergents. Use lint-free cleaning rags.
- 4.2.10 Before cleaning the machine with water, steam jet (high pressure cleaning) or detergents, cover or tape up all openings which – for safety and functional reasons – must be protected against water, steam or detergents penetration. Special care must be taken with electric motors and switch gear cabinets.
- 4.2.11 Ensure during cleaning of the machine that the temperature sensors of the fire warning and fire-fighting systems do not come into contact with hot cleaning against as this might activate the fire-fighting system of the plant.
- 4.2.12 After cleaning, remove all covers and tapes applied for that purpose.
- 4.2.13 After cleaning, examine all pipe lines for leaks, loose connections, chafe marks and damage. Any defects found must be rectified without delay.
- 4.2.14 Always tighten any screwed connections that have been loosened during maintenance and repair.
- 4.2.15 Any safety devices removed for maintenance or repair purposes must be refitted and checked immediately upon completion of the maintenance and repair work.
- 4.2.16 Ensure that all consumables and replaced parts are disposed safely and with minimum environmental impact.

## **5 Warning of special dangers**

### **5.1 Electric energy**

- 5.1.1 Use only original fuses with the specified current rating. Switch off the machine immediately if trouble occurs in the electrical system.

- 5.1.2 Work on the electrical system or equipment may only be carried out by a skilled electrician himself or by specially instructed personnel under the control and supervision of such electrician and in accordance with the applicable electrical engineering rules.
- 5.1.3 If provided for in the regulations, the power supply to parts of machines and plants, on which inspection, maintenance and repair work is to be carried out must be cut off. Before starting any work, check the de-energized parts for presence of power and ground or short circuit them in addition to insulating adjacent live parts and elements.
- 5.1.4 The electrical equipment of machines is to be inspected and checked at regular intervals. Defects such as loose connections or scorched cables must be rectified immediately.
- 5.1.5 Necessary work on live parts and elements must be carried out only in the presence of a second person who can cut off the power supply in case of danger by actuating the emergency shut-off or main power switch. Secure working area with a red – and – white safety chain and a warning sign. Use insulated tools only.

## **5.2 Gas, dust, steam and smoke**

- 5.2.1 Carry out welding, flame-cutting and grinding work on the machine/plant only if this has been expressly authorized, as there may be a risk of explosion and fire.
- 5.2.2 Before carrying out welding, flame-cutting and grinding operations, clean the machine/plants and its surroundings from dust and other inflammable substances and make sure that the premises are adequately ventilated (risk of explosion).

## **5.3 Pneumatic equipment**

- 5.3.1 Work on pneumatic equipment may be carried out only by persons having special knowledge and experience in pneumatic systems.
- 5.3.2 Check all lines and screwed connections regularly for leaks and obvious damage. Repair damage immediately. Penetrating compressed air respectively gases and cause injury and fire.
- 5.3.3 Depressurize all systems sections and pressure pipes to be removed before carrying out any repair work.
- 5.3.4 Compressed air lines must be laid and fitted properly. Ensure that no connections are interchanged. The fittings, length and quality of the hoses must comply with the technical requirements.

## **5.4 Noise**

- 5.4.1 During operation, all sound baffles must be closed.
- 5.4.2 Always wear the prescribed ear protector.

## **5.5 Oil, grease and other chemical substances**

Observe the product-related safety regulations when handling oil, grease and other chemical substances.

## **6 Transport of machinery and equipment (changing place of operation)**

- 6.1 For loading only use lifting gear and tackle of sufficient capacity.
- 6.2 Appoint a competent marshaller to assist in the lifting operations.
- 6.3 Lift machinery and equipment properly with suitable lifting gear and only in accordance with the operating instructions (fixing points for lifting tackle, etc.).
- 6.4 Only use suitable means of transport of adequate carrying capacity.
- 6.5 Fasten the loads safely using the suitable fixing points.
- 6.6 For transport provide the machine with transport protection if necessary. Before putting the machine into operation please remove the transport protection properly.
- 6.7 Carefully refit and fasten all parts to be removed for transport purposes before re-commissioning the machine.
- 6.8 Cut off the external power supply of the machine even if only minor changes of place are envisaged. Properly re-connect the machine even if only minor changes of place commissioning.
- 6.9 For re-commissioning only proceed in accordance with the operating instructions.

# Bushehr MEG Plant Project

VENDOR NAME	: Airpack Nederland B.V
EQUIPMENT DESCRIPTION	: Nitrogen & Instrument Booster Package
EQUIPMENT TAGNUMBER	: 20-C-1002, 20-C-7080

## SECTION 2

### NITROGEN GAS BOOSTER



Vendor doc. Number

17811-20

Vendor:

Airpack Nederland B.V.

P.O. NO.:

MEG20-PO-BP303-021

SHEET QTY: 34

2	Nitrogen gas booster.....	3
2.1	Installation and Commissioning.....	3
2.1.1	Safety.....	3
2.2	Requirements for the installation location.....	6
2.2.1	Ambient conditions.....	6
2.2.2	Installation in areas at risk of frost.....	6
2.2.3	Attachment.....	7
2.2.4	Pipeline connection.....	8
2.2.5	Electrical connections.....	9
2.2.6	Drive.....	10
2.2.7	Requirement: safe dissipation of gases.....	10
2.3	Commissioning.....	11
2.3.1	Checks prior to commissioning (compressor block and unit).....	11
2.3.2	Check oil fill / oil level.....	13
2.3.3	Checking coolant filling.....	13
2.3.4	Starting and checking when starting (compressor block and units).....	14
2.3.5	Check oil pressure and oil temperature.....	15
2.3.6	Cooling function check.....	15
2.4	Operation.....	16
2.4.1	Safety.....	16
2.4.2	Activities prior to use.....	17
2.4.3	During operation.....	17
2.5	Shutting down in an emergency.....	20
2.6	Operational disruptions.....	20
2.6.1	Safety.....	21
2.6.2	What to do in the event of operational disruptions.....	22
2.6.3	Faults / troubleshooting.....	22
2.6.4	Commissioning following operational disruption resolution.....	26
2.7	Maintenance.....	26
2.7.1	Safety.....	27
2.7.2	Maintenance preparations.....	30
2.7.3	Maintenance plan.....	32

## 2 Nitrogen gas booster

### 2.1 Installation and Commissioning

In this section the proper set-up, installation and commissioning of the machine are described.

#### Personnel

- Installation and commissioning may not be performed by the operator. A service engineer from Airpack Netherlands B.V is required to attend.
- Work on the non-electrical equipment of the compressor block must only be performed by specialist personnel qualified for that purpose.
- Work on electrical components must only be performed by electrical specialists.

#### 2.1.1 Safety

##### **! DANGER**



#### Danger posed by falling loads

Serious injuries or death from falling loads.

- Do not step under suspended loads.
- Maintain a sufficient safety distance to suspended loads.
- Prior to transportation, compare weight per piece and bearing capacity of the lifting equipment and mechanisms.
- Use only specified sling points.

#### Personal protective equipment

##### **! WARNING**

#### Injury during transport!

Hazardous situations may arise during transport tasks which may lead to injuries.

- Wear personal protective equipment during transport work.



Industrial helmet – Safety shoes – Cut-resistant gloves



Pay attention to accident prevention guidelines and / or other national guidelines.

**Welding, cutting and grinding work****! WARNING****Risk of fire / explosion**

Welding, cutting and grinding work may cause fires or explosions.

- Only perform welding, cutting and grinding work following the express consent of the operator.
- Prior to commencing welding, cutting or grinding work, clean the surroundings of dust and flammable substances.
- Ensure adequate aeration in the work area.

**Frost damage****ATTENTION****Property damage due to frozen cooling fluid**

Temperatures below the freezing point may cause frost damage to the compressor block.

- Comply with the permissible temperature range for installation (see "Technical data" in the appendix section)
- If the temperature range cannot be kept to during installation and commissioning, add adequate antifreeze to the cooling media.

	<b>BUSHEHR MEG PLANT PROJECT</b>	Rev.: 00 Date: 08-11-2024
	Nitrogen Gas Booster	

## Overhead installation work

# CAUTION



### **Machine parts used as climbing aids for overhead installation work.**

Injuries due to falling from height in the event of overhead installation work where machine parts are used as climbing aids.

- Do not use machine parts as climbing aids.
- Use safety-compliant climbing aids and work platforms.
- For maintenance work at great heights, wear fall protection devices.
- Keep handles, steps, rails, platforms and ladders free of dirt, snow and ice.

## Notice

The notes provided below relate to the seamless functioning of the compressor block and the conditions necessary for this.

The safety-related requirements for the set-up and operation of the compressor block determined by the type of gas to be compressed are to be observed by the operator.

## **2.1.1.1 Supplementary measures for operation in areas at risk of explosion**

### **Risk of explosion**

# ! WARNING



### **Risk of explosion due to inadequate implementation of protective measures**

In order to prevent the risk of explosion and potentially serious injuries, certain protective measures must be taken when operating the machine in areas at risk of explosion.

- Only allow specially trained specialist personnel to perform work in areas at risk of explosion.
- Ensure the requirements described below are met.

	<b>BUSHEHR MEG PLANT PROJECT</b>	Rev.: 00 Date: 08-11-2024
	Nitrogen Gas Booster	

### **Minimizing the risk of explosion**

- Ensure that there is adequate ventilation.
- Ensure that all electrical components are designed for areas at risk of explosion.
- Only allow specially trained specialist personnel to perform work in areas at risk of explosion.
- Only use instruments and tools which do not generate any sparks.

## **2.2 Requirements for the installation location**

### **2.2.1 Ambient conditions**

The following should be ensured for the installation of the machine throughout its time of use:

- Ensure machine stability.
- The installation area must have adequate load-bearing capacity for the weight of the machine. This is listed in the "Technical data" in the appendix section.
- Comply with the temperature range stipulated in the specifications in the technical data.
- Ensure adequate ventilation.
- For outdoor installation: Provide a weather-protection roof.
- Spatial requirements: ensure sufficient space for maintenance work in all directions.

### **2.2.2 Installation in areas at risk of frost**

When compressor blocks/units are installed in areas at risk of frost, the following general notes are to be observed for air- and water-cooled compressors which compress gases with a relative humidity greater than 10%.

#### **Lubrication**

When lubricating the compressor block, you must ensure that the oil viscosity – and potentially the ambient temperature is adjusted, or oil heating must be provided.

#### **Condensate**

Condensate is produced during the compression and cooling of atmospheric air or humid gases.

	<b>BUSHEHR MEG PLANT PROJECT</b>	Rev.: 00 Date: 08-11-2024
	Nitrogen Gas Booster	

## ATTENTION



### **Damage caused by freezing condensate / residues of cooling water.**

Significant damage may be caused to the compressor block due to the freezing of condensate / residues of cooling water. Condensate/residues may lead to cracks on / in the following assemblies:

- Yoke
- Cylinder block
- Cylinder head
- Prevent the ambient temperature from falling below +5°C during operation or when at a standstill, because otherwise the condensate / residues of cooling water will freeze.
- In the event of ambient temperature below +5°C, measures must be taken to prevent freezing condensate / cooling water on the assemblies mentioned.

### **Coolant**

The antifreeze of the compressor cooling circuit (primary cooling circuit) can be ensured using a water-glycol mixture. An ex-works recommendation is presented in the "Technical data" section.

### **Decommissioning**

When taking compressor blocks out of service in areas at risk of frost, the condensate / cooling water must be drained at all drain points. The cooling water circuit of water-cooled compressor blocks must be purged with glycol before shutdown or storage in areas at risk of frost.

## 2.2.3 Attachment

There are 4 holes on the drive unit of the compressor block for fixing the compressor block to the skid. The compressor block is to be installed in an upright position using 4 fixing screws. The diameter of the holes is specified on the dimensional drawing; the thread size and the tightening torque under "Compressor block tightening torques". Both are in the "Appendix" section of these operating instructions.

### **Specifications**

Component	Feature	Value
Foundation	Evenness	0.5 above the support surface width of the compressor block
Fixing screws	Strength class	8.8

	<b>BUSHEHR MEG PLANT PROJECT</b>	Rev.: 00 Date: 08-11-2024
	Nitrogen Gas Booster	

## 2.2.4 Pipeline connection

Notes for the connection of pipelines and hose lines are described in this section.

### DANGER



#### **Risk of suffocation posed by leaks!**

Faulty connection of the connection pipes may lead to leaks.

- Use fitting screw connections for the pipe connection.
- Check the leak-tightness of the connection once the pipe connection is complete

#### **Connection pipes**

The connection positions of the supply and discharge pipes are indicated in section 3 "Product description" and in the dimensional drawing in the appendix of these operating instructions.

The requisite nominal values of the connections can be found on the dimensional drawing and the P&ID

#### **Control air pipes**

### WARNING



#### **Control air pipes incorrectly laid and installed**

Pneumatically actuated control and shut-off valves are not working and cannot perform their safety tasks.

- Route and install the compressed air pipes for the control air pipes.
- Ensure correct connections.
- Ensure that fittings, length, and quality of hose lines meet the requirements.

#### **Flange connection tightening torques**

Tightening torques as outlined in standard DIN EN 1591-1 are to be used for the fitting of flange connections. Customer services at Airpack Netherlands B.V. can be contacted in the event of any questions.

	<b>BUSHEHR MEG PLANT PROJECT</b>	Rev.: 00 Date: 08-11-2024
	Nitrogen Gas Booster	

## Pipelines

- Supply pipes originating from the container are to be dimensioned based on the maximum volume flow rate.
- Connecting pipes between the compressor block/unit and containers connected on the suction and pressure sides are usually designed as rigid pipelines.
- Galvanised steel piping and rust-free steel can be used for pipeline material.
- The nominal width of the connecting pipe between compressor block/unit and pressure vessel is based on the nominal connection width on the compressor block/unit.
- Establishing the connection using (sufficiently heat-resistant) expansion joints, so as to prevent strain caused by vibrations, is recommended.
- The pipelines must be supported to absorb reactive forces.
- The enclosed instructions "Notes on pipeline construction in the context of piston compressors" must be observed.
- Pipelines must be free of welding work and dirt residues prior to commissioning.

## 2.2.5 Electrical connections

The electrical installation of the machine must be performed on site and must satisfy the requirements of standard EN 60204-1.

For operation in areas at risk of explosion, the requirements of standard EN 1127-1 must also be met.

### Electrical current

## DANGER



### Risk of fatality due to electric shock!

Serious injuries through to fatality.

- Have work on electrical equipment and devices performed exclusively by electrical specialists, as described in the section "Safety", under "Personnel qualification".

### Additional notes

Furthermore, the following **notes** must be observed:

- The electrical fusing of the machine must meet the specifications under "technical data" and the specifications in the circuit diagram.

	<b>BUSHEHR MEG PLANT PROJECT</b>	Rev.: 00 Date: 08-11-2024
	Nitrogen Gas Booster	

- If the machine is not equipped with an electrical main switch, this must be installed by the operator so that all electrically conductive parts of the machine are carrying no current following shutdown.

## 2.2.6 Drive

### V-belt drive

For compressor blocks, the drive disc of the compressor block is contained within the scope of delivery. The necessary specifications of the compressor block (power requirement, compressor speed, diameter of drive disc of the compressor block, etc.) are contained in the "Technical data" and on the dimensional drawing.

Design and installation must be performed at the customer's taking applicable standards and regulations into account.

The following must be considered for the set-up calculation:

- The drive disc of the compressor block is to be designed as per DIN 2211.
- A V-belt profile as per DIN 7753 is to be provided for the V-belt drive.
- The calculation and design of the V-belt drive is to be performed in accordance with the specifications of the V-belt manufacturer.

## 2.2.7 Requirement: safe dissipation of gases

### Hazardous discharging gases **DANGER**



#### **Contact with discharging gases with hazardous properties!**

Injuries or risk of fatality in the case of physical contact or inhalation.

- Conduct away discharging gases or vapours with hazardous properties safely.

#### **Discharge possibilities of hazardous gases**

Discharge options exist for compressor blocks e.g. on safety equipment, shaft and rod seals, drain and relief equipment. The requirement for safe dissipation is fulfilled if gases or vapours are collected right at the point of discharge and channelled away or, if this is not possible, there is sufficient ventilation of the installation room.

**Additional requirements of related local ordinances and legislation at the location of installation must be complied with.**

#### **Drain, vent and relief pipes**

For drain, vent and relief pipes, the following applies:

- Gases discharged from drain, vent and relief pipes are to be channelled away safely.

- Drain, vent and relief pipes for readily flammable, poisonous or oxidising gases must not flow into rooms.
- Drain, vent and relief pipes for readily flammable gases must be designed for the forces of explosion if explosive gas/air mixtures can develop in them.
- The vent line must discharge in a depressurised manner. Discharge against a counter-pressure is not permitted.
- The vent line must be routed so that drainage is possible at the deepest point. For this purpose, the pipe should slope downwards slightly after the safety valve. An immediate rising of the pipe after a safety valve is not permitted.
- A guard against rain, dirt and animal habitation should be introduced at the end of a vent line if required.

## 2.3 Commissioning

### 2.3.1 Checks prior to commissioning (compressor block and unit)

#### ATTENTION



**Damage to the compressor block due to excessive pressure ratio or excessively high temperature!**

In the event of a **test operation** with air or nitrogen, one must therefore observe:

- The **pressure ratio** may be **max. 4**.
- The **discharge temperature** at the compressor block must not exceed **max. 180°C**.

		Reference	Commissioning
	<b>Testing</b>		
1	Determine the guidelines and standards conformity of the overall system in which the compressor block / compressor unit is integrated.		<input type="checkbox"/>
2	Ensure that prescribed leak-tightness tests of the overall system have been successfully performed (pressure test as per operator regulations).		<input type="checkbox"/>
3	On-site electrical connections for correct configuration and, in the case of operation in areas at risk of explosion, for suitability for operation in areas at risk of explosion.	5.3.3	<input type="checkbox"/>
4	Check the earthing / potential equalisation of all parts.		<input type="checkbox"/>
5	Ensure that pipelines / hose lines are properly connected.	5.3.2	<input type="checkbox"/>
6	Check oil filling / oil level of the compressor block.	5.6.2	<input type="checkbox"/>
7	Check coolant filling / coolant level. (In the case of water-cooled compressor blocks)	5.6.3	<input type="checkbox"/>
8	Check turning direction of the compressor block. Turning direction must match the turning direction arrow on the compressor block.		<input type="checkbox"/>
9	Check the turning direction of the fan. (In the case of air-cooled compressor blocks / air coolers)		<input type="checkbox"/>
10	Discharge cock on the pressure vessel must be opened.		<input type="checkbox"/>
11	Check prescribed settings of measurement, control and switching devices.		<input type="checkbox"/>
12	Ensure that filling and drain screws, as well as vent/drain valves that are present, are tightly shut.		<input type="checkbox"/>
13	Shut-off valve in the suction and pressure pipe (if present) must be opened.		<input type="checkbox"/>
14	Pressure gauge and pressure shut-off valves (if present) must be opened.		<input type="checkbox"/>
15	Purging gas pipe (if present) must be shut.		<input type="checkbox"/>

## 2.3.2 Check oil fill / oil level

The oil level is checked at the oil inspection glass in the event of a standstill of the compressor block.

Maximum: Oil inspection glass center level

Minimum: Oil inspection glass quarter level

## 2.3.3 Checking coolant filling

Prior to each commissioning of compressor blocks, one must ensure that all liquid-cooled components are properly supplied with liquid.

### Coolant

Clean water that is not too hard must be used as a coolant and for treating with antifreeze. The following is not appropriate: Mine water, sea water, brackish water, salt water and industrial wastewater. Also note the specifications of the "Technical data" in the appendix to these instructions in this regard.

## ATTENTION



### • Damage due to insufficient cooling!

Insufficient cooling of the compressor block's compression chambers, or none at all, may lead to serious damage and even to the destruction of the compressor block after just brief operation.

- This is why an automatic temperature monitoring facility is essential for the cooling water. Water-cooled compressor blocks are usually equipped with a temperature monitoring device which ensures that the compressor block is automatically shut down in the event of excessive cooling water temperatures.
- If the automatic temperature monitoring is not part of the order, appropriate temperature monitoring devices must be installed at the location.
- Do not exceed the maximum permissible pressure of 2 bar for the cooling water.
- The maximum permitted cooling water discharge temperature of 55°C in the compressor block must not be exceeded.
- In the event of the risk of frost, adequate antifreeze must be ensured for the entire cooling system.

**Filling / draining**

Prior to commissioning, the coolant chambers of the compressor block must be filled with coolant through the supply pipe provided for this purpose.

1. Shut the venting taps / drain taps.
2. Open temperature control fully.

**NOTICE**

Air pocket formation

- Allow coolant to flow in quickly.
3. The coolant chambers of the compressor block are properly filled and vented once coolant flows toward the cooling water outlet through the vent pipe (if present).
  4. Shut the temperature control and then open again with approx. 2 turns.

**Precise temperature adjustment can only be made when the machine is running.**

**Draining / venting**

The coolant of the compressor block may have to be partially or fully drained for maintenance or repair work.

**WARNING**

**Hot coolant!**

Risk of burns.

- Only drain coolant when it is in a cool state.
1. Open the coolant drain cock and discharge the requisite amount of coolant into a suitable container through a hose to be attached to the drain cock.
  2. If no coolant flows out after opening the coolant drain cock, a vent cock must be opened at the cooling water outlet.

Before refilling, shut the coolant drain taps and venting taps once more.

**2.3.4 Starting and checking when starting  
(compressor block and units)**

1. Switch on the main switch
2. Make sure all valves are in the correct position
3. Make sure cooling is flowing through the compressor and coolers

4. Start the package
5. Check oil pressure
6. Check cooling functioning
7. Do a functional check of the whole system

## 2.3.5 Check oil pressure and oil temperature

The oil pressure is pre-set to the set pressure at the factory.

1. Check oil pressure

The specifications regarding oil pressure are listed in the technical data in the P&ID

### ATTENTION



#### Oil pressure too low!

Even short-term operation with too little oil pressure may cause severe subsequent damage to the compressor block.

- Ensure the oil pressure stays above the minimum admissible oil pressure.
- oil pressure transmitter is installed for monitoring.

## 2.3.6 Cooling function check

1. Ensure that coolant flow is present.
2. If there is no coolant flow then the compressor block may need to be vented, because air pockets may have formed.

	<b>BUSHEHR MEG PLANT PROJECT</b>	Rev.: 00 Date: 08-11-2024
	Nitrogen Gas Booster	

## 2.4 Operation

This section describes the safe and efficient operation of the machine.

### 2.4.1 Safety

#### Protective equipment

## DANGER



#### **Risk of fatality due to tampered or defective protective equipment!**

Danger zones may become accessible or dangers may not be able to be averted by protective equipment which has been tampered with or is defective. This leads to serious injuries or fatality.

- Only operate the compressor block/unit with fully attached and functional protective equipment.
- Emergency-Off buttons must be accessible at all times.

#### Fault conditions

## WARNING



#### **Risk of injury posed by operation in a faulty state!**

Damage, defects or deficiencies to the compressor block/unit may pose a threat to personnel.

- Check the compressor block/unit for outwardly noticeable damage, defects or deficiencies once per shift.
- Shut the compressor block/unit down immediately and secure it against reactivation.
- Report any damage, defects or deficiencies that arise immediately to superiors.

#### Malfunctions

## WARNING



#### **Risk of injury posed by malfunctions of the compressor block/unit!**

Malfunctions may lead to personnel being endangered.

	<b>BUSHEHR MEG PLANT PROJECT</b>	Rev.: 00 Date: 08-11-2024
	Nitrogen Gas Booster	

- Shut the compressor block/unit down immediately in the event of malfunctions and secure it against reactivation.
- Notify superiors.
- Eliminate the cause of faults prior to reactivation.

### Unexpected start-up

## CAUTION



### **Risk of injury posed by unexpected compressor block/unit start-up!**

Unexpected start-up of the compressor block/unit may lead to injuries.

- Prior to activating the compressor block/unit, ensure that no persons are endangered (especially from a remote start-up release from a control room).

## 2.4.2 Activities prior to use

Prior to using the machine, carry out the following activities:

1. Ensure correct installation of all protective covers.
2. Ensure that there is no external damage to the machine.
3. Ensure that there is no damage to the electrical connections.
4. Ensure that there are no longer people in the danger zone / performing work in the danger zone.
5. Ensure that a successful test run has been performed prior to operation, "Commissioning".

## 2.4.3 During operation

During operation of the machine, no personnel are required around the machine or in its immediate vicinity. The machine is operated via the control system for the overall system (operating instructions for the overall system).

Nevertheless, the following notes and checks are important for safe and efficient operation and are to be performed.

### 2.4.3.1 Notes on load-free operation

#### Intermittent control

For intermittent control, the machine is switched off upon reaching the final pressure and the solenoid relief valve opens. For idling control, the compressor block continues running in a depressurized state.

## ATTENTION



**Damage to the pressure valves due to long-lasting load-free operation!**

If the machine has a gripper control for idling operation (suction valve lifting), the duration of load-free operation (gripper control active) may be **max. 5 minutes**.

In the case of 50%-setting and double-acting machines, the suction valves on the cover side and the crank side must thus be actuated for idle mode **every 5 minutes in alternation!**

If this value is exceeded, one must assume damage to the pressure valves.

**If the machine has a bypass valve for idling operation (pressure / suction side short-circuit), the duration of idling operation is not limited.**

### 2.4.3.2 Checks during operation

## WARNING



**Check when the machine is running!**

Document the checks.

## WARNING



**Injury hazard from touching hot surfaces or contact with hot operating resources!**

During operation, machine parts and operating resources reach high temperatures. Contact with machine parts or operating resources may cause burns.

- Avoid touching the hot surfaces of axes and motors to prevent burning your skin.
- Wear protective gloves if working on hot surfaces is necessary.

During machine operation, the following operating parameters are to be checked and logged on a daily basis:

**Compressor lubrication:**

- Oil level
- Oil pressure

**Compressor cooling (in the case of water-cooled compressor blocks)**

- Cooling water discharge temperature max. 55°C

## ATTENTION

**Condensation from process medium**

Serious damage to the compressor block, especially to the gas-carrying components.

- The temperature of the coolant in the compressor block must be higher than the dew point of the gas to be compressed.
- To prevent condensation in the compressor block, the cooling water inlet temperature must be at least 5°C above the gas inlet temperature.

**Condensate discharge:**

- ball valve

**Suction and pressure pipe:**

- Gas inlet temperature per compression stage
- Gas discharge temperature per compression stage
- Gas inlet pressure per compression stage
- Gas discharge pressure per compression stage

	<b>BUSHEHR MEG PLANT PROJECT</b>	Rev.: 00 Date: 08-11-2024
	Nitrogen Gas Booster	

See the rating plate of the compressor skid and the "Technical data"

The operating parameters are to be checked both on the measuring instruments on the compressor block (pressure gauge and thermometer) and on the measuring instruments installed on site.

Faults can only be detected promptly, and dangers thereby prevented, with regular checks.

## 2.5 Shutting down in an emergency

In dangerous situations, machine movements must be stopped as quickly as possible and the power supply must be switched off.

In the event of danger, do the following:

1. Trigger the machine's emergency-off function.
2. Remove people from the danger zone and initiate first-aid measures.
3. Make emergency calls; notify the ambulance and fire brigade.
4. Notify the superior at the location of use about the fault.
5. Switch off the machine at the main switch and secure it against reactivation.
6. Ensure unobstructed access routes for rescue vehicles.
7. Should the severity of the emergency require it, notify the competent authorities.
8. Entrust specialist personnel with troubleshooting.

### **WARNING!**

Risk of fatality posed by premature reactivation.

- Prior to reactivation, make sure that personnel are no longer in the danger zone.

9. Check the system prior to recommissioning and make sure that all the safety equipment is installed and functional.

## 2.6 Operational disruptions

In this section, the possible causes of faults and troubleshooting are described. If faults occur with increasing frequency, adjust the maintenance intervals according to actual loads. In the event of faults which cannot be resolved using the following notes, contact the manufacturer (see the contact data at the start of the operating instructions).

### **What to do in the event of faults**

	<b>BUSHEHR MEG PLANT PROJECT</b>	Rev.: 00 Date: 08-11-2024
	Nitrogen Gas Booster	

Local safety regulations apply in all cases to the operation of the machine, irrespective of the instructions below.

### Safety shutdown

Prior to commencing work on troubleshooting, installation, servicing or repair

- Render the **machine powerless** (shut down at the main switch)
- **and**, in the case of work on pressurised parts, also render the system **depressurised**.

We strongly recommend **a lockable in situ interrupter**, which prevents unintentional machine reactivation in the event of repairs or troubleshooting.

## 2.6.1 Safety

### Personnel

- Some work must only be performed by specially qualified specialist personnel or exclusively by the manufacturer, which is specifically emphasised in the description of the individual faults.
- Work on the electrical system must strictly only be performed by electrical specialists.

### Personal protective equipment

Wear protective equipment for all fault work:

- Safety shoes
- Eye protection

### Unexpected start-up

## WARNING



**Risk of injury posed by unexpected compressor block/unit start-up!**

Unexpected start-up of the compressor block/unit may lead to injuries.

- Prior to activating the compressor block/unit, ensure that no persons are endangered (especially from a remote start-up release from a control room).

### Uncontrolled start-up

## WARNING

**Uncontrolled start-up of the machine!**

Injuries to personnel.

- Install a lockable in situ interrupter, which prevents unintentional machine reactivation in the event of repairs or troubleshooting.

## 2.6.2 What to do in the event of operational disruptions

**As a rule:**

1. In the event of faults posing an immediate danger to personnel or property, trigger the emergency-off function of the machine immediately.
2. Determine the cause of the fault.
3. Immediately notify the superior at the location of use about the fault.
4. If troubleshooting necessitates working in the danger zone, switch the machine off and secure it against reactivation.
5. Have the fault resolved by authorized specialist personnel or, if authorization for resolution is provided in the fault table, resolve it yourself.

## 2.6.3 Faults / troubleshooting

Q: Qualified technical staff

T: Trained personnel

	<b>BUSHEHR MEG PLANT PROJECT</b>	Rev.: 00 Date: 08-11-2024
	Nitrogen Gas Booster	

E: Electrical specialist

The qualification of personnel to which the above abbreviations refer is described in section "Safety".

<b>Occurrence / fault</b>	<b>Possible cause</b>	<b>Troubleshooting</b>	<b>Resolved by</b>
Falling pressure or low volume flow	Suction filter soiled	Clean filter insert, replace after lengthy operation	I
	Pipelines or valves leaking	Search and seal leak points with leak-detecting spray	I
	Suction/pressure valves are leaking	Remove valves and check; replace if necessary	Q
	Valve lifting mechanism not working	Remove valve lifting mechanism; check for smooth running; lubricate with PFPE lubricant, or replace diaphragm	Q
	Piston rings worn	Replace piston rings	Q

Occurrence / fault		Possible cause	Troubleshooting	Resolved by
Oil pressure too low		Insufficient oil in the crankcase	Top up oil	I
		Excessively thin oil in the crankcase	Oil does not conform to manufacturer recommendations (technical data); replace oil and replace with an appropriate one	I
		Oil screen / oil filter blocked	Clean or replace oil screen / oil filter	I
		Enlarged bearing play (connecting rod, crankshaft)	Set oil pressure higher with regulating screw	I
Compressor block becomes hot (Higher gas discharge temperature is normal)	General	Pressure valves are leaking	Remove valves and check; replace if necessary	Q
		Piston rings are worn	Replace piston rings	Q
	Air-cooled compressor blocks	Blower V-belt tension too low or V-belts are defective	Re-tighten V-belt; replace if necessary	I
		Protective grating in front of blower dirty	Clean protective grating	I
		Inadequate ventilation	Ensure decent cooling air supply	I
		incorrect rotation direction	Ensure that the cooling air from the fan is blowing in the direction of the compressor block	I
	Water-cooled compressor blocks	Strainer in cooling water supply pipe blocked	Clean strainers	I
		Thermostatic valve misaligned or defective	Check thermostatic valve; replace if necessary	Q
		Insufficient pressure in the cooling water supply pipe	Ensure higher pressure: At least 1.5 to 2 bar	I

Occurrence / fault	Possible cause	Troubleshooting	Resolved by
	Excessive cooling water temperature	Ensure lower temperature or higher	Q

		flow rate; if necessary, connect compressor block and cooler separately.	
	Deposits in the cooling water spaces of the compressor block	Detach and clean compressor block	Q
Compressor block starts up with difficulty	Start-up relief not working	Check relief device	Q
	Non-return valve leaking	Detach and clean non-return valve	Q
Motor protection switches off due to overloading	Compressor block running against excessively high pressure: <ul style="list-style-type: none"> <li>• pressure pipe throttled</li> <li>• Pressure switch set too high</li> <li>• Excessive pressure in suction pipe</li> </ul>	Check pressure ratios	Q
	Line voltage too low	Check voltage directly on the motor or switching device	E
	Drive unit bearing or crosshead seized up (Compressor disc only rotates with difficulty)	Check components; replace if necessary	Q
	Jamming of piston rings due to excess temperatures (Compressor disc only rotates with difficulty)	Check components; replace if necessary	Q
Compressor block runs unevenly	V-belt loosened	Re-tensioning V-belt	I

*Fault table*

## NOTICE

If a fault occurs with the compressor block which is not described here, please refer to customer services at Airpack Netherlands BV.

	<b>BUSHEHR MEG PLANT PROJECT</b>	Rev.: 00 Date: 08-11-2024
	Nitrogen Gas Booster	

The contact data is presented in section 7 "Maintenance".

## 2.6.4 Commissioning following operational disruption resolution

Once the operational disruption has been resolved, take the following steps:

1. Check firm fitting of previously released screw connections and secure if necessary.
2. Ensure the proper functioning of all previously removed covers and protective equipment.
3. Remove tools and work materials from out of the work area.
4. Clean the machine/work area and, if necessary, remove discharged substances (liquids, processing material, etc.) and dispose of them in an environmentally friendly manner.
5. Ensure the correct installation of all the machine's safety equipment and that it is working properly.
6. Machines for the compression of **dangerous gases** must be purged prior to reactivation **in accordance with section 5 "Purging"**.

### Note on compressing dangerous gases

## DANGER!

Explosion with risk of fatality to personnel!

- **Purge** compressor blocks for flammable gases or vapours **prior to opening and prior to start-up after opening** to prevent explosive gas/air or vapour/air mixtures from forming.
7. Put the machine back into operation in accordance with the notes in the section "Commissioning".

### Premature reactivation

## WARNING!

Risk of fatality posed by premature reactivation of the machine!

- Prior to the reactivation of the machine, ensure that people are no longer in the danger zone / are no longer performing work in the danger zone.

## 2.7 Maintenance

Please contact our customer service department if you would like to order spare parts or have questions about maintenance and servicing of the compressor block:

	<b>BUSHEHR MEG PLANT PROJECT</b>	Rev.: 00 Date: 08-11-2024
	Nitrogen Gas Booster	

Airpack Netherlands BV

## NOTICE

### Ordering spare parts

Correct spare part deliveries are only ensured if ordered correctly with the appropriate serial number of the compressor block and ordering number of the spare part.

## 2.7.1 Safety

### Important

The safety information and notes in section 2 "Safety", the safety notes in this section and the warning notes immediately after the action steps must be read and understood.

### Personnel

- Provided nothing else is indicated, the maintenance work described here can be performed by the service personnel of the operator.
- Inspections, wear checks and work on the pressurised and/or gas-carrying components with which the compressor block must be opened must only be performed by qualified specialist personnel as described in section 2. The maintenance and installation instructions, as well as all safety and accident prevention regulations should be observed in this regard.

### Personal protective equipment

- Safety shoes
- Protective gloves

### Pressurised components

## WARNING



### Unexpected pressure equalisation when opening pressurised components!

Injuries due to flinging around or the unexpected discharge of pressurised gases.

- Prior to maintenance or repair work, take the machine out of service completely, depressurise it and secure it against reactivation.
- Only allow wear checks and work on pressurised components of the machine to be performed by qualified specialist personnel.

### Faulty maintenance

## WARNING

**Incorrectly performed maintenance work!**

Improper maintenance work may cause injuries.

- Comply with stipulated maintenance intervals.
- Ensure to correctly re-install removed components.
- Pay attention to stipulated tightening torques when installing components.

**Securing against reactivation****WARNING****Unauthorised reactivation of the machine**

Unauthorised machine reactivation during maintenance and repair work could lead to injuries to maintenance personnel.

- Prior to maintenance or repair work, switch off the machine on the main switch and secure it against reactivation.

**Hot surfaces and operating resources****WARNING****Hot surfaces and operating resources due to operation!**

During operation, machine parts and operating resources reach high temperatures. Contact with machine parts or operating resources may cause burns.

- Prior to starting work, check temperature of surfaces or operating resources; if necessary, wait for them to cool down.
- Wear protective gloves if working on hot surfaces is necessary.

**Incorrect spare parts and accessories****WARNING****Incorrect spare parts and accessories!**

	<b>BUSHEHR MEG PLANT PROJECT</b>	Rev.: 00 Date: 08-11-2024
	Nitrogen Gas Booster	

Compressor block components are subject to considerable stress. Spare parts not approved by Airpack Netherlands BV may be unable to withstand this type of stress. Failing non-approved components may cause serious injuries.

- Use only spare parts approved by Airpack Netherlands BV.

### Overhead installation work

## CAUTION



### **Machine parts used as climbing aids for overhead installation work.**

Injuries due to falling from height in the event of overhead installation work where machine parts are used as climbing aids.

- Do not use machine parts as climbing aids.
- Use safety-compliant climbing aids and work platforms.
- For maintenance work at great heights, wear fall protection devices.
- Keep handles, steps, rails, platforms and ladders free of dirt, snow and ice.

### Environmental protection

Dispose of materials, machine parts and accumulated work materials properly in accordance with local rules and regulations. (See also section 2 "Safety" – "Environmental protection")

## 2.7.1.1 Special notes regarding dangerous gases and operation in areas at risk of explosion

Explosive atmosphere

## DANGER

**Potentially explosive atmospheres!**

Death or serious injury due to explosion.

- No open flames; no fire, open ignition source, or smoking!
- Unauthorised access denied!
- Stay in areas at risk of explosion only as long as is necessary for performing your work.
- Keep mobile phones switched off!
- Immediately leave the danger zone in the event of a gas alarm.
- Comply with the emergency plan drawn up by the owner.

**Explosion due to discharging gases****DANGER****Risk of explosion when opening process gas-conveying components of the compressor block.**

When opening process gas-carrying components of the compressor block, residual quantities of the process gas are discharged. They may create an explosive atmosphere.

- Prior to commencing with maintenance and repair work, process-gas-carrying components must be purged to displace the process gas.
- Check adequate purging.
- Only have work on the compressor block performed by qualified specialists.

## 2.7.2 Maintenance preparations

Prior to commencing maintenance work, depressurisation must be performed. Compressor blocks for the compression of dangerous gases must also be purged.

### 2.7.2.1 Depressurising compressor block

Prior to commencing with maintenance work on the compressor block, pressure must be released. Appropriate valves for blocking and relieving the compressor block in the overall system in which the compressor block is installed must be arranged on site.

#### System state

Component	State
Main switch	OFF and secured against reactivation
Compressor block	Pressurised

#### Personal protective equipment

- Safety shoes
- Eye protection

#### Repressurisation

## WARNING



**Repressurisation inside the compressor block after depressurisation has been performed!**

Risk of injury posed by pressurised components.

- Keep shut-off valves of the gas supply pipes shut during maintenance work.
- Keep ball valves in open position for pressure relief during maintenance work.

### 2.7.2.2 Purging the compressor block

Prior to commencing maintenance work the crank drive and the gas-carrying area of the compressor block must be purged (inerted) with purging gas.

The purging process must be performed for every compressor block individually.

#### System state

Component	State
Main switch	OFF and secured against reactivation

	<b>BUSHEHR MEG PLANT PROJECT</b>	Rev.: 00 Date: 08-11-2024
	Nitrogen Gas Booster	

Compressor block	Depressurised
------------------	---------------

## 2.7.3 Maintenance plan

The sections that follow describe the maintenance work that will ensure that the system operates in an optimum way and free of faults.

### Maintenance intervals

The intervals specified in the maintenance plan are recommendations which are influenced by the operating conditions (suction and final pressure), as well as the gas to be compressed (purity, humidity [humid, dry with dew point up to "bone dry"]).

The maintenance plan specifies the maintenance intervals for the first 8,000 operating hours.

After this point, the inspections are to be conducted in line with experience gained thus far regarding spare part wear.

### Recommended first inspection

After **2,000 operating hours**, the first inspection of the compressor block should take place. The level of wear of the individual assemblies (valves, pistons, oil and gas gland) and the general condition of the compressor block is assessed.

### Adapting maintenance intervals

If increased wear is identified during the regular inspections, then the maintenance intervals should be adapted appropriately to the actual incidence of wear in consultation with the manufacturer.

### Personnel

The definitions of personnel qualifications are described in section 2 of these operating instructions.

Symbol	Meaning
TP	Trained person
QP	Qualified specialist personnel with special training
E	Electrical specialist
I	Approved inspection body / for the inspection of competent personnel as per national regulations

	Actions required after operating hours:		Daily	50 to 500	2000	every 4,000	every 8,000	every 32,000	every 40,000
	Latest due after months:						every 12		every 60
Qualification	Component	Task							



**BUSHEHR MEG PLANT PROJECT**

Rev.: 00  
Date: 08-11-2024

Nitrogen Gas Booster

TP	Operating parameters	Checking	▪		▪		▪		
TP	Compressor block	Check for noises and running behaviour	▪		▪		▪		
TP	Compressor block	Drain condensate	▪		▪		▪		
TP	Oil	Check fill level and condition	▪		▪		▪		
QP	Oil	Change			▪		▪		
QP	Oil filter	Change			▪		▪		
QP	Control unit, valve control unit	Checking			▪	▪	▪		
QP	Suction valve lifting	Lubrication			▪		▪		
QP	Suction and pressure valves *) / (**)	Inspection			▪		▪		
QP	Valve chambers	Inspection for deposits			▪		▪		
QP	Piston	Check ring grooves						▪	
QP	Piston and guide rings *) / (**)	Inspection			▪		▪		
QP	Piston rod	Inspection						▪	

In the event of questions regarding maintenance work and intervals, contact the manufacturer; see the contact data for customer services at the start of this section.

	Actions required after operating hours:	Daily	50 tot 500	2000	Every 4,000	Every 8.000	Every 32.000	Every 40.000
	Latest due after months:					Every 12		Every 60
Qualification	Component	Task						
QP	Gas gland *) / (**)	Inspection			▪		▪	
QP	Non-return valve purging gas outlet / leakage gas, yoke	Checking					▪	
QP	Non-return valve for leakage gas return to suction side	Checking					▪	
QP	Cylinder liner	Inspection						▪
QP	Cylinder and Cylinder head	Check cooling						▪

		water chambers and clean if necessary							
QP	Oil gland *) / **)	Inspection					▪		
QP	Crankcase	Remove covers and check bearings visually					▪		
QP	Screw connections of piston	Change screws							▪
QP	All bearings	Check visually							▪
QP	Crosshead	Inspection and change bolts							▪
QP	Oil pump	Check							▪
QP	Oil pressure regulator	Functional test							▪
QP	Screw connections	Re-tightening			▪		▪		▪

	Actions required after operating hours:		Daily	50 tot 500	2.000	Every 4.000	Every 8.000	Every 32.000	Every 40.000
	Latest due after months:						Every 12		Every 60
Qualification	Component	Task							
QP	V-belt (if installed)	Re-tightening		▪	▪	▪			
QP	V-belt (if installed)	Check; re-tighten or replace if necessary			▪	▪			
QP	Coupling (if installed)	Check wear			▪		▪		

\*) If increased wear is detectable during the inspection, the maintenance intervals are to be shortened. \*\*) If the components are heavily worn, they must be replaced.

# Bushehr MEG Plant Project

<b>VENDOR NAME</b>	: Airpack Nederland B.V
<b>EQUIPMENT DESCRIPTION</b>	: Nitrogen & Instrument Booster Package
<b>EQUIPMENT TAGNUMBER</b>	: 20-C-1002, 20-C-7080

## SECTION 3

### EMERGENCY INSTRUMENT AIR COMPRESSOR



Vendor doc. Number

17811-20

Vendor:

Airpack Nederland B.V.

P.O. NO.:

MEG20-PO-BP303-021

SHEET QTY: 34

3.	Nitrogen gas booster.....	3
3.1	Installation and Commissioning.....	3
3.1.1	Safety.....	3
3.2	Requirements for the installation location.....	6
3.2.1	Ambient conditions.....	6
3.2.2	Installation in areas at risk of frost.....	6
3.2.3	Attachment.....	7
3.2.4	Pipeline connection.....	8
3.2.5	Electrical connections.....	9
3.2.6	Drive.....	10
3.2.7	Requirement: safe dissipation of gases.....	10
3.3	Commissioning.....	11
3.3.1	Checks prior to commissioning (compressor block and unit).....	11
3.3.2	Check oil fill / oil level.....	13
3.3.3	Checking coolant filling.....	13
3.3.4	Starting and checking when starting (compressor block and units).....	14
3.3.5	Check oil pressure and oil temperature.....	15
3.3.6	Cooling function check.....	15
3.4	Operation.....	16
3.4.1	Safety.....	16
3.4.2	Activities prior to use.....	17
3.4.3	During operation.....	17
3.5	Shutting down in an emergency.....	20
3.6	Operational disruptions.....	20
3.6.1	Safety.....	21
3.6.2	What to do in the event of operational disruptions.....	22
3.6.3	Faults / troubleshooting.....	22
3.6.4	Commissioning following operational disruption resolution.....	25
3.7	Maintenance.....	26
3.7.1	Safety.....	26
3.7.2	Maintenance preparations.....	30
3.7.3	Maintenance plan.....	31

## 3. Nitrogen gas booster

### 3.1 Installation and Commissioning

In this section the proper set-up, installation and commissioning of the machine are described.

#### Personnel

- Installation and commissioning may not be performed by the operator. A service engineer from Airpack Netherlands B.V is required to attend.
- Work on the non-electrical equipment of the compressor block must only be performed by specialist personnel qualified for that purpose.
- Work on electrical components must only be performed by electrical specialists.

#### 3.1.1 Safety

##### **! DANGER**



#### Danger posed by falling loads

Serious injuries or death from falling loads.

- Do not step under suspended loads.
- Maintain a sufficient safety distance to suspended loads.
- Prior to transportation, compare weight per piece and bearing capacity of the lifting equipment and mechanisms.
- Use only specified sling points.

#### Personal protective equipment

##### **! WARNING**

#### Injury during transport!

Hazardous situations may arise during transport tasks which may lead to injuries.

- Wear personal protective equipment during transport work.



Industrial helmet – Safety shoes – Cut-resistant gloves



Pay attention to accident prevention guidelines and / or other national guidelines.

### **Welding, cutting and grinding work**

## **! WARNING**



### **Risk of fire / explosion**

Welding, cutting and grinding work may cause fires or explosions.

- Only perform welding, cutting and grinding work following the express consent of the operator.
- Prior to commencing welding, cutting or grinding work, clean the surroundings of dust and flammable substances.
- Ensure adequate aeration in the work area.

### **Frost damage**

## **ATTENTION**



### **Property damage due to frozen cooling fluid**

Temperatures below the freezing point may cause frost damage to the compressor block.

- Comply with the permissible temperature range for installation (see "Technical data" in the appendix section)
- If the temperature range cannot be kept to during installation and commissioning, add adequate antifreeze to the cooling media.

	<b>BUSHEHR MEG PLANT PROJECT</b>	Rev.: 00 Date: 08-11-2024
	Emergency instrument air compressor	

## Overhead installation work

# CAUTION



### **Machine parts used as climbing aids for overhead installation work.**

Injuries due to falling from height in the event of overhead installation work where machine parts are used as climbing aids.

- Do not use machine parts as climbing aids.
- Use safety-compliant climbing aids and work platforms.
- For maintenance work at great heights, wear fall protection devices.
- Keep handles, steps, rails, platforms and ladders free of dirt, snow and ice.

## Notice

The notes provided below relate to the seamless functioning of the compressor block and the conditions necessary for this.

The safety-related requirements for the set-up and operation of the compressor block determined by the type of gas to be compressed are to be observed by the operator.

### **3.1.1.1 Supplementary measures for operation in areas at risk of explosion**

#### **Risk of explosion**

## ! WARNING



### **Risk of explosion due to inadequate implementation of protective measures**

In order to prevent the risk of explosion and potentially serious injuries, certain protective measures must be taken when operating the machine in areas at risk of explosion.

- Only allow specially trained specialist personnel to perform work in areas at risk of explosion.
- Ensure the requirements described below are met.

	<b>BUSHEHR MEG PLANT PROJECT</b>	Rev.: 00 Date: 08-11-2024
	Emergency instrument air compressor	

### **Minimizing the risk of explosion**

- Ensure that there is adequate ventilation.
- Ensure that all electrical components are designed for areas at risk of explosion.
- Only allow specially trained specialist personnel to perform work in areas at risk of explosion.
- Only use instruments and tools which do not generate any sparks.

## **3.2 Requirements for the installation location**

### **3.2.1 Ambient conditions**

The following should be ensured for the installation of the machine throughout its time of use:

- Ensure machine stability.
- The installation area must have adequate load-bearing capacity for the weight of the machine. This is listed in the "Technical data" in the appendix section.
- Comply with the temperature range stipulated in the specifications in the technical data.
- Ensure adequate ventilation.
- For outdoor installation: Provide a weather-protection roof.
- Spatial requirements: ensure sufficient space for maintenance work in all directions.

### **3.2.2 Installation in areas at risk of frost**

When compressor blocks/units are installed in areas at risk of frost, the following general notes are to be observed for air- and water-cooled compressors which compress gases with a relative humidity greater than 10%.

#### **Lubrication**

When lubricating the compressor block, you must ensure that the oil viscosity – and potentially the ambient temperature is adjusted, or oil heating must be provided.

#### **Condensate**

Condensate is produced during the compression and cooling of atmospheric air or humid gases.

# ATTENTION



## **Damage caused by freezing condensate / residues of cooling water.**

Significant damage may be caused to the compressor block due to the freezing of condensate / residues of cooling water. Condensate/residues may lead to cracks on / in the following assemblies:

- Yoke
- Cylinder block
- Cylinder head
- Prevent the ambient temperature from falling below +5°C during operation or when at a standstill, because otherwise the condensate / residues of cooling water will freeze.
- In the event of ambient temperature below +5°C, measures must be taken to prevent freezing condensate / cooling water on the assemblies mentioned.

### **Coolant**

The antifreeze of the compressor cooling circuit (primary cooling circuit) can be ensured using a water-glycol mixture. An ex-works recommendation is presented in the "Technical data" section.

### **Decommissioning**

When taking compressor blocks out of service in areas at risk of frost, the condensate / cooling water must be drained at all drain points. The cooling water circuit of water-cooled compressor blocks must be purged with glycol before shutdown or storage in areas at risk of frost.

## **3.2.3 Attachment**

There are 4 holes on the drive unit of the compressor block for fixing the compressor block to the skid. The compressor block is to be installed in an upright position using 4 fixing screws. The diameter of the holes is specified on the dimensional drawing; the thread size and the tightening torque under "Compressor block tightening torques". Both are in the "Appendix" section of these operating instructions.

### **Specifications**

Component	Feature	Value
Foundation	Evenness	0.5 above the support surface width of the compressor block
Fixing screws	Strength class	8.8

### 3.2.4 Pipeline connection

Notes for the connection of pipelines and hose lines are described in this section.

## DANGER



### **Risk of suffocation posed by leaks!**

Faulty connection of the connection pipes may lead to leaks.

- Use fitting screw connections for the pipe connection.
- Check the leak-tightness of the connection once the pipe connection is complete

### **Connection pipes**

The connection positions of the supply and discharge pipes are indicated in section 3 "Product description" and in the dimensional drawing in the appendix of these operating instructions.

The requisite nominal values of the connections can be found on the dimensional drawing and the P&ID

### **Control air pipes**

## WARNING



### **Control air pipes incorrectly laid and installed**

Pneumatically actuated control and shut-off valves are not working and cannot perform their safety tasks.

- Route and install the compressed air pipes for the control air pipes.
- Ensure correct connections.
- Ensure that fittings, length, and quality of hose lines meet the requirements.

### **Flange connection tightening torques**

Tightening torques as outlined in standard DIN EN 1591-1 are to be used for the fitting of flange connections. Customer services at Airpack Netherlands B.V. can be contacted in the event of any questions.

	<b>BUSHEHR MEG PLANT PROJECT</b>	Rev.: 00 Date: 08-11-2024
	Emergency instrument air compressor	

## Pipelines

- Supply pipes originating from the container are to be dimensioned based on the maximum volume flow rate.
- Connecting pipes between the compressor block/unit and containers connected on the suction and pressure sides are usually designed as rigid pipelines.
- Galvanised steel piping and rust-free steel can be used for pipeline material.
- The nominal width of the connecting pipe between compressor block/unit and pressure vessel is based on the nominal connection width on the compressor block/unit.
- Establishing the connection using (sufficiently heat-resistant) expansion joints, so as to prevent strain caused by vibrations, is recommended.
- The pipelines must be supported to absorb reactive forces.
- The enclosed instructions "Notes on pipeline construction in the context of piston compressors" must be observed.
- Pipelines must be free of welding work and dirt residues prior to commissioning.

### 3.2.5 Electrical connections

The electrical installation of the machine must be performed on site and must satisfy the requirements of standard EN 60204-1.

For operation in areas at risk of explosion, the requirements of standard EN 1127-1 must also be met.

#### Electrical current

## DANGER



#### Risk of fatality due to electric shock!

Serious injuries through to fatality.

- Have work on electrical equipment and devices performed exclusively by electrical specialists, as described in the section "Safety", under "Personnel qualification".

#### Additional notes

Furthermore, the following **notes** must be observed:

- The electrical fusing of the machine must meet the specifications under "technical data" and the specifications in the circuit diagram.

	<b>BUSHEHR MEG PLANT PROJECT</b>	Rev.: 00 Date: 08-11-2024
	Emergency instrument air compressor	

- If the machine is not equipped with an electrical main switch, this must be installed by the operator so that all electrically conductive parts of the machine are carrying no current following shutdown.

### 3.2.6 Drive

#### V-belt drive

For compressor blocks, the drive disc of the compressor block is contained within the scope of delivery. The necessary specifications of the compressor block (power requirement, compressor speed, diameter of drive disc of the compressor block, etc.) are contained in the "Technical data" and on the dimensional drawing.

Design and installation must be performed at the customer's taking applicable standards and regulations into account.

The following must be considered for the set-up calculation:

- The drive disc of the compressor block is to be designed as per DIN 2211.
- A V-belt profile as per DIN 7753 is to be provided for the V-belt drive.
- The calculation and design of the V-belt drive is to be performed in accordance with the specifications of the V-belt manufacturer.

### 3.2.7 Requirement: safe dissipation of gases

#### Hazardous discharging gases **DANGER**



#### **Contact with discharging gases with hazardous properties!**

Injuries or risk of fatality in the case of physical contact or inhalation.

- Conduct away discharging gases or vapours with hazardous properties safely.

#### **Discharge possibilities of hazardous gases**

Discharge options exist for compressor blocks e.g. on safety equipment, shaft and rod seals, drain and relief equipment. The requirement for safe dissipation is fulfilled if gases or vapours are collected right at the point of discharge and channelled away or, if this is not possible, there is sufficient ventilation of the installation room.

**Additional requirements of related local ordinances and legislation at the location of installation must be complied with.**

#### **Drain, vent and relief pipes**

For drain, vent and relief pipes, the following applies:

	<b>BUSHEHR MEG PLANT PROJECT</b>	Rev.: 00 Date: 08-11-2024
	Emergency instrument air compressor	

- Gases discharged from drain, vent and relief pipes are to be channelled away safely.
- Drain, vent and relief pipes for readily flammable, poisonous or oxidising gases must not flow into rooms.
- Drain, vent and relief pipes for readily flammable gases must be designed for the forces of explosion if explosive gas/air mixtures can develop in them.
- The vent line must discharge in a depressurised manner. Discharge against a counter-pressure is not permitted.
- The vent line must be routed so that drainage is possible at the deepest point. For this purpose, the pipe should slope downwards slightly after the safety valve. An immediate rising of the pipe after a safety valve is not permitted.
- A guard against rain, dirt and animal habitation should be introduced at the end of a vent line if required.

### 3.3 Commissioning

#### 3.3.1 Checks prior to commissioning (compressor block and unit)

#### ATTENTION



**Damage to the compressor block due to excessive pressure ratio or excessively high temperature!**

In the event of a **test operation** with air or nitrogen, one must therefore observe:

- The **pressure ratio** may be **max. 4**.
- The **discharge temperature** at the compressor block must not exceed **max. 180°C**.

		Reference	Commissioning
	<b>Testing</b>		
1	Determine the guidelines and standards conformity of the overall system in which the compressor block / compressor unit is integrated.		<input type="checkbox"/>
2	Ensure that prescribed leak-tightness tests of the overall system have been successfully performed (pressure test as per operator regulations).		<input type="checkbox"/>
3	On-site electrical connections for correct configuration and, in the case of operation in areas at risk of explosion, for suitability for operation in areas at risk of explosion.	5.3.3	<input type="checkbox"/>
4	Check the earthing / potential equalisation of all parts.		<input type="checkbox"/>
5	Ensure that pipelines / hose lines are properly connected.	5.3.2	<input type="checkbox"/>
6	Check oil filling / oil level of the compressor block.	5.6.2	<input type="checkbox"/>
7	Check coolant filling / coolant level. (In the case of water-cooled compressor blocks)	5.6.3	<input type="checkbox"/>
8	Check turning direction of the compressor block. Turning direction must match the turning direction arrow on the compressor block.		<input type="checkbox"/>
9	Check the turning direction of the fan. (In the case of air-cooled compressor blocks / air coolers)		<input type="checkbox"/>
10	Discharge cock on the pressure vessel must be opened.		<input type="checkbox"/>
11	Check prescribed settings of measurement, control and switching devices.		<input type="checkbox"/>
12	Ensure that filling and drain screws, as well as vent/drain valves that are present, are tightly shut.		<input type="checkbox"/>
13	Shut-off valve in the suction and pressure pipe (if present) must be opened.		<input type="checkbox"/>
14	Pressure gauge and pressure shut-off valves (if present) must be opened.		<input type="checkbox"/>
15	Purging gas pipe (if present) must be shut.		<input type="checkbox"/>

### 3.3.2 Check oil fill / oil level

The oil level is checked at the oil inspection glass in the event of a standstill of the compressor block.

Maximum: Oil inspection glass center level

Minimum: Oil inspection glass quarter level

### 3.3.3 Checking coolant filling

Prior to each commissioning of compressor blocks, one must ensure that all liquid-cooled components are properly supplied with liquid.

#### Coolant

Clean water that is not too hard must be used as a coolant and for treating with antifreeze. The following is not appropriate: Mine water, sea water, brackish water, salt water and industrial wastewater. Also note the specifications of the "Technical data" in the appendix to these instructions in this regard.

## ATTENTION



#### • **Damage due to insufficient cooling!**

Insufficient cooling of the compressor block's compression chambers, or none at all, may lead to serious damage and even to the destruction of the compressor block after just brief operation.

- This is why an automatic temperature monitoring facility is essential for the cooling water. Water-cooled compressor blocks are usually equipped with a temperature monitoring device which ensures that the compressor block is automatically shut down in the event of excessive cooling water temperatures.
- If the automatic temperature monitoring is not part of the order, appropriate temperature monitoring devices must be installed at the location.
- Do not exceed the maximum permissible pressure of 2 bar for the cooling water.
- The maximum permitted cooling water discharge temperature of 55°C in the compressor block must not be exceeded.
- In the event of the risk of frost, adequate antifreeze must be ensured for the entire cooling system.

**Filling / draining**

Prior to commissioning, the coolant chambers of the compressor block must be filled with coolant through the supply pipe provided for this purpose.

1. Shut the venting taps / drain taps.
2. Open temperature control fully.

**NOTICE**

Air pocket formation

➤ Allow coolant to flow in quickly.

3. The coolant chambers of the compressor block are properly filled and vented once coolant flows toward the cooling water outlet through the vent pipe (if present).

4. Shut the temperature control and then open again with approx. 2 turns.

**Precise temperature adjustment can only be made when the machine is running.**

**Draining / venting**

The coolant of the compressor block may have to be partially or fully drained for maintenance or repair work.

**WARNING**

**Hot coolant!**

Risk of burns.

➤ Only drain coolant when it is in a cool state.

1. Open the coolant drain cock and discharge the requisite amount of coolant into a suitable container through a hose to be attached to the drain cock.

2. If no coolant flows out after opening the coolant drain cock, a vent cock must be opened at the cooling water outlet.

Before refilling, shut the coolant drain taps and venting taps once more.

**3.3.4 Starting and checking when starting  
(compressor block and units)**

1. Switch on the main switch

	<b>BUSHEHR MEG PLANT PROJECT</b>	Rev.: 00 Date: 08-11-2024
	Emergency instrument air compressor	

2. Make sure all valves are in the correct position
3. Make sure cooling is flowing through the compressor and coolers
4. Start the package
5. Check oil pressure
6. Check cooling functioning
7. Do a functional check of the whole system

### 3.3.5 Check oil pressure and oil temperature

The oil pressure is pre-set to the set pressure at the factory.

1. Check oil pressure

The specifications regarding oil pressure are listed in the technical data in the P&ID

## ATTENTION



- **Oil pressure too low!**

Even short-term operation with too little oil pressure may cause severe subsequent damage to the compressor block.

- Ensure the oil pressure stays above the minimum admissible oil pressure.
- oil pressure transmitter is installed for monitoring.

### 3.3.6 Cooling function check

1. Ensure that coolant flow is present.
2. If there is no coolant flow then the compressor block may need to be vented, because air pockets may have formed.

## 3.4 Operation

This section describes the safe and efficient operation of the machine.

### 3.4.1 Safety

#### Protective equipment

## DANGER



#### **Risk of fatality due to tampered or defective protective equipment!**

Danger zones may become accessible or dangers may not be able to be averted by protective equipment which has been tampered with or is defective. This leads to serious injuries or fatality.

- Only operate the compressor block/unit with fully attached and functional protective equipment.
- Emergency-Off buttons must be accessible at all times.

#### Fault conditions

## WARNING



#### **Risk of injury posed by operation in a faulty state!**

Damage, defects or deficiencies to the compressor block/unit may pose a threat to personnel.

- Check the compressor block/unit for outwardly noticeable damage, defects or deficiencies once per shift.
- Shut the compressor block/unit down immediately and secure it against reactivation.
- Report any damage, defects or deficiencies that arise immediately to superiors.

#### Malfunctions

## WARNING



#### **Risk of injury posed by malfunctions of the compressor block/unit!**

	<b>BUSHEHR MEG PLANT PROJECT</b>	Rev.: 00 Date: 08-11-2024
	Emergency instrument air compressor	

Malfunctions may lead to personnel being endangered.

- Shut the compressor block/unit down immediately in the event of malfunctions and secure it against reactivation.
- Notify superiors.
- Eliminate the cause of faults prior to reactivation.

### Unexpected start-up

## CAUTION



**Risk of injury posed by unexpected compressor block/unit start-up!**

Unexpected start-up of the compressor block/unit may lead to injuries.

- Prior to activating the compressor block/unit, ensure that no persons are endangered (especially from a remote start-up release from a control room).

### 3.4.2 Activities prior to use

Prior to using the machine, carry out the following activities:

1. Ensure correct installation of all protective covers.
2. Ensure that there is no external damage to the machine.
3. Ensure that there is no damage to the electrical connections.
4. Ensure that there are no longer people in the danger zone / performing work in the danger zone.
5. Ensure that a successful test run has been performed prior to operation, "Commissioning".

### 3.4.3 During operation

During operation of the machine, no personnel are required around the machine or in its immediate vicinity. The machine is operated via the control system for the overall system (operating instructions for the overall system).

Nevertheless, the following notes and checks are important for safe and efficient operation and are to be performed.

### 3.4.3.1 Notes on load-free operation

#### Intermittent control

For intermittent control, the machine is switched off upon reaching the final pressure and the solenoid relief valve opens. For idling control, the compressor block continues running in a depressurized state.

## ATTENTION



**Damage to the pressure valves due to long-lasting load-free operation!**

If the machine has a gripper control for idling operation (suction valve lifting), the duration of load-free operation (gripper control active) may be **max. 5 minutes**.

In the case of 50%-setting and double-acting machines, the suction valves on the cover side and the crank side must thus be actuated for idle mode **every 5 minutes in alternation!**

If this value is exceeded, one must assume damage to the pressure valves.

**If the machine has a bypass valve for idling operation (pressure / suction side short-circuit), the duration of idling operation is not limited.**

### 3.4.3.2 Checks during operation

## WARNING



**Check when the machine is running!**

Document the checks.

## WARNING



**Injury hazard from touching hot surfaces or contact with hot operating resources!**

During operation, machine parts and operating resources reach high temperatures. Contact with machine parts or operating resources may cause burns.

- Avoid touching the hot surfaces of axes and motors to prevent burning your skin.
- Wear protective gloves if working on hot surfaces is necessary.

During machine operation, the following operating parameters are to be checked and logged on a daily basis:

**Compressor lubrication:**

- Oil level
- Oil pressure

**Compressor cooling (in the case of water-cooled compressor blocks)**

- Cooling water discharge temperature max. 55°C

## ATTENTION

**Condensation from process medium**

Serious damage to the compressor block, especially to the gas-carrying components.

- The temperature of the coolant in the compressor block must be higher than the dew point of the gas to be compressed.
- To prevent condensation in the compressor block, the cooling water inlet temperature must be at least 5°C above the gas inlet temperature.

**Condensate discharge:**

- ball valve

**Suction and pressure pipe:**

- Gas inlet temperature per compression stage
- Gas discharge temperature per compression stage
- Gas inlet pressure per compression stage

	<b>BUSHEHR MEG PLANT PROJECT</b>	Rev.: 00 Date: 08-11-2024
	Emergency instrument air compressor	

- Gas discharge pressure per compression stage

See the rating plate of the compressor skid and the "Technical data"

The operating parameters are to be checked both on the measuring instruments on the compressor block (pressure gauge and thermometer) and on the measuring instruments installed on site.

Faults can only be detected promptly, and dangers thereby prevented, with regular checks.

### 3.5 Shutting down in an emergency

In dangerous situations, machine movements must be stopped as quickly as possible and the power supply must be switched off.

In the event of danger, do the following:

1. Trigger the machine's emergency-off function.
2. Remove people from the danger zone and initiate first-aid measures.
3. Make emergency calls; notify the ambulance and fire brigade.
4. Notify the superior at the location of use about the fault.
5. Switch off the machine at the main switch and secure it against reactivation.
6. Ensure unobstructed access routes for rescue vehicles.
7. Should the severity of the emergency require it, notify the competent authorities.
8. Entrust specialist personnel with troubleshooting.

### WARNING!

Risk of fatality posed by premature reactivation.

- Prior to reactivation, make sure that personnel are no longer in the danger zone.

9. Check the system prior to recommissioning and make sure that all the safety equipment is installed and functional.

### 3.6 Operational disruptions

In this section, the possible causes of faults and troubleshooting are described. If faults occur with increasing frequency, adjust the maintenance intervals according to actual

	<b>BUSHEHR MEG PLANT PROJECT</b>	Rev.: 00 Date: 08-11-2024
	Emergency instrument air compressor	

loads. In the event of faults which cannot be resolved using the following notes, contact the manufacturer (see the contact data at the start of the operating instructions).

### What to do in the event of faults

Local safety regulations apply in all cases to the operation of the machine, irrespective of the instructions below.

### Safety shutdown

Prior to commencing work on troubleshooting, installation, servicing or repair

- Render the **machine powerless** (shut down at the main switch)
- **and**, in the case of work on pressurised parts, also render the system **depressurised**.

We strongly recommend **a lockable in situ interrupter**, which prevents unintentional machine reactivation in the event of repairs or troubleshooting.

## 3.6.1 Safety

### Personnel

- Some work must only be performed by specially qualified specialist personnel or exclusively by the manufacturer, which is specifically emphasised in the description of the individual faults.
- Work on the electrical system must strictly only be performed by electrical specialists.

### Personal protective equipment

Wear protective equipment for all fault work:

- Safety shoes
- Eye protection

### Unexpected start-up

## WARNING



### Risk of injury posed by unexpected compressor block/unit start-up!

Unexpected start-up of the compressor block/unit may lead to injuries.

- Prior to activating the compressor block/unit, ensure that no persons are endangered (especially from a remote start-up release from a control room).

**Uncontrolled start-up**

**WARNING**



**Uncontrolled start-up of the machine!**

Injuries to personnel.

- Install a lockable in situ interrupter, which prevents unintentional machine reactivation in the event of repairs or troubleshooting.

### 3.6.2 What to do in the event of operational disruptions

**As a rule:**

1. In the event of faults posing an immediate danger to personnel or property, trigger the emergency-off function of the machine immediately.
2. Determine the cause of the fault.
3. Immediately notify the superior at the location of use about the fault.
4. If troubleshooting necessitates working in the danger zone, switch the machine off and secure it against reactivation.
5. Have the fault resolved by authorized specialist personnel or, if authorization for resolution is provided in the fault table, resolve it yourself.

### 3.6.3 Faults / troubleshooting

Q: Qualified technical staff

T: Trained personnel

E: Electrical specialist

The qualification of personnel to which the above abbreviations refer is described in section "Safety".

Occurrence / fault	Possible cause	Troubleshooting	Resolved by
--------------------	----------------	-----------------	-------------



**BUSHEHR MEG PLANT PROJECT**

Rev.: 00  
Date: 08-11-2024

Emergency instrument air compressor

Falling pressure or low volume flow	Suction filter soiled	Clean filter insert, replace after lengthy operation	I
	Pipelines or valves leaking	Search and seal leak points with leak-detecting spray	I
	Suction/pressure valves are leaking	Remove valves and check; replace if necessary	Q
	Valve lifting mechanism not working	Remove valve lifting mechanism; check for smooth running; lubricate with PFPE lubricant, or replace diaphragm	Q
	Piston rings worn	Replace piston rings	Q

Occurrence / fault		Possible cause	Troubleshooting	Resolved by
Oil pressure too low		Insufficient oil in the crankcase	Top up oil	I
		Excessively thin oil in the crankcase	Oil does not conform to manufacturer recommendations (technical data); replace oil and replace with an appropriate one	I
		Oil screen / oil filter blocked	Clean or replace oil screen / oil filter	I
		Enlarged bearing play (connecting rod, crankshaft)	Set oil pressure higher with regulating screw	I
Compressor block becomes hot (Higher gas discharge temperature is normal)	General	Pressure valves are leaking	Remove valves and check; replace if necessary	Q
		Piston rings are worn	Replace piston rings	Q
	Air-cooled compressor blocks	Blower V-belt tension too low or V-belts are defective	Re-tighten V-belt; replace if necessary	I
		Protective grating in front of blower dirty	Clean protective grating	I



**BUSHEHR MEG PLANT PROJECT**

Rev.: 00  
Date: 08-11-2024

Emergency instrument air compressor

		Inadequate ventilation	Ensure decent cooling air supply	I
		incorrect rotation direction	Ensure that the cooling air from the fan is blowing in the direction of the compressor block	I
	Water-cooled compressor blocks	Strainer in cooling water supply pipe blocked	Clean strainers	I
		Thermostatic valve misaligned or defective	Check thermostatic valve; replace if necessary	Q
		Insufficient pressure in the cooling water supply pipe	Ensure higher pressure: At least 1.5 to 2 bar	I

Occurrence / fault	Possible cause	Troubleshooting	Resolved by
	Excessive cooling water temperature	Ensure lower temperature or higher flow rate; if necessary, connect compressor block and cooler separately.	Q
	Deposits in the cooling water spaces of the compressor block	Detach and clean compressor block	Q
Compressor block starts up with difficulty	Start-up relief not working	Check relief device	Q
	Non-return valve leaking	Detach and clean non-return valve	Q
Motor protection switches off due to overloading	Compressor block running against excessively high pressure: <ul style="list-style-type: none"> <li>• pressure pipe throttled</li> <li>• Pressure switch set too high</li> <li>• Excessive pressure in suction pipe</li> </ul>	Check pressure ratios	Q
	Line voltage too low	Check voltage directly on the motor or switching device	E
	Drive unit bearing or crosshead seized up (Compressor disc only rotates with difficulty)	Check components; replace if necessary	Q

	<b>BUSHEHR MEG PLANT PROJECT</b>	Rev.: 00 Date: 08-11-2024
	Emergency instrument air compressor	

	Jamming of piston rings due to excess temperatures (Compressor disc only rotates with difficulty)	Check components; replace if necessary	Q
Compressor block runs unevenly	V-belt loosened	Re-tensioning V-belt	I

*Fault table*

## NOTICE

If a fault occurs with the compressor block which is not described here, please refer to customer services at Airpack Netherlands BV.

The contact data is presented in section 7 "Maintenance".

### 3.6.4 Commissioning following operational disruption resolution

Once the operational disruption has been resolved, take the following steps:

1. Check firm fitting of previously released screw connections and secure if necessary.
2. Ensure the proper functioning of all previously removed covers and protective equipment.
3. Remove tools and work materials from out of the work area.
4. Clean the machine/work area and, if necessary, remove discharged substances (liquids, processing material, etc.) and dispose of them in an environmentally friendly manner.
5. Ensure the correct installation of all the machine's safety equipment and that it is working properly.
6. Machines for the compression of **dangerous gases** must be purged prior to reactivation **in accordance with section 5 "Purging"**.

#### Note on compressing dangerous gases

## DANGER!

Explosion with risk of fatality to personnel!

- **Purge** compressor blocks for flammable gases or vapours **prior to opening and prior to start-up after opening** to prevent explosive gas/air or vapour/air mixtures from forming.
7. Put the machine back into operation in accordance with the notes in the section "Commissioning".

	<b>BUSHEHR MEG PLANT PROJECT</b>	Rev.: 00 Date: 08-11-2024
	Emergency instrument air compressor	

### Premature reactivation

## WARNING!

Risk of fatality posed by premature reactivation of the machine!

- Prior to the reactivation of the machine, ensure that people are no longer in the danger zone / are no longer performing work in the danger zone.

## 3.7 Maintenance

Please contact our customer service department if you would like to order spare parts or have questions about maintenance and servicing of the compressor block:

Airpack Netherlands BV

## NOTICE

### Ordering spare parts

Correct spare part deliveries are only ensured if ordered correctly with the appropriate serial number of the compressor block and ordering number of the spare part.

### 3.7.1 Safety

#### Important

The safety information and notes in section 2 "Safety", the safety notes in this section and the warning notes immediately after the action steps must be read and understood.

#### Personnel

- Provided nothing else is indicated, the maintenance work described here can be performed by the service personnel of the operator.
- Inspections, wear checks and work on the pressurised and/or gas-carrying components with which the compressor block must be opened must only be performed by qualified specialist personnel as described in section 2. The maintenance and installation instructions, as well as all safety and accident prevention regulations should be observed in this regard.

#### Personal protective equipment

- Safety shoes
- Protective gloves

**Pressurised components****WARNING****Unexpected pressure equalisation when opening pressurised components!**

Injuries due to flinging around or the unexpected discharge of pressurised gases.

- Prior to maintenance or repair work, take the machine out of service completely, depressurise it and secure it against reactivation.
- Only allow wear checks and work on pressurised components of the machine to be performed by qualified specialist personnel.

**Faulty maintenance****WARNING****Incorrectly performed maintenance work!**

Improper maintenance work may cause injuries.

- Comply with stipulated maintenance intervals.
- Ensure to correctly re-install removed components.
- Pay attention to stipulated tightening torques when installing components.

**Securing against reactivation****WARNING****Unauthorised reactivation of the machine**

Unauthorised machine reactivation during maintenance and repair work could lead to injuries to maintenance personnel.

- Prior to maintenance or repair work, switch off the machine on the main switch and secure it against reactivation.

**Hot surfaces and operating resources****WARNING**

**Hot surfaces and operating resources due to operation!**

During operation, machine parts and operating resources reach high temperatures. Contact with machine parts or operating resources may cause burns.

- Prior to starting work, check temperature of surfaces or operating resources; if necessary, wait for them to cool down.
- Wear protective gloves if working on hot surfaces is necessary.

**Incorrect spare parts and accessories****WARNING****Incorrect spare parts and accessories!**

Compressor block components are subject to considerable stress. Spare parts not approved by Airpack Netherlands BV may be unable to withstand this type of stress. Failing non-approved components may cause serious injuries.

- Use only spare parts approved by Airpack Netherlands BV.

**Overhead installation work****CAUTION****Machine parts used as climbing aids for overhead installation work.**

Injuries due to falling from height in the event of overhead installation work where machine parts are used as climbing aids.

- Do not use machine parts as climbing aids.
- Use safety-compliant climbing aids and work platforms.
- For maintenance work at great heights, wear fall protection devices.
- Keep handles, steps, rails, platforms and ladders free of dirt, snow and ice.

**Environmental protection**

	<b>BUSHEHR MEG PLANT PROJECT</b>	Rev.: 00 Date: 08-11-2024
	Emergency instrument air compressor	

Dispose of materials, machine parts and accumulated work materials properly in accordance with local rules and regulations. (See also section 2 "Safety" – "Environmental protection")

### 3.7.1.1 Special notes regarding dangerous gases and operation in areas at risk of explosion

Explosive atmosphere

**DANGER**



**Potentially explosive atmospheres!**

Death or serious injury due to explosion.

- No open flames; no fire, open ignition source, or smoking!
- Unauthorised access denied!
- Stay in areas at risk of explosion only as long as is necessary for performing your work.
- Keep mobile phones switched off!
- Immediately leave the danger zone in the event of a gas alarm.
- Comply with the emergency plan drawn up by the owner.

Explosion due to discharging gases

**DANGER**



**Risk of explosion when opening process gas-conveying components of the compressor block.**

When opening process gas-carrying components of the compressor block, residual quantities of the process gas are discharged. They may create an explosive atmosphere.

- Prior to commencing with maintenance and repair work, process-gas-carrying components must be purged to displace the process gas.

	<b>BUSHEHR MEG PLANT PROJECT</b>	Rev.: 00 Date: 08-11-2024
	Emergency instrument air compressor	

- Check adequate purging.
- Only have work on the compressor block performed by qualified specialists.

## 3.7.2 Maintenance preparations

Prior to commencing maintenance work, depressurisation must be performed. Compressor blocks for the compression of dangerous gases must also be purged.

### 3.7.2.1 Depressurising compressor block

Prior to commencing with maintenance work on the compressor block, pressure must be released. Appropriate valves for blocking and relieving the compressor block in the overall system in which the compressor block is installed must be arranged on site.

#### System state

Component	State
Main switch	OFF and secured against reactivation
Compressor block	Pressurised

#### Personal protective equipment

- Safety shoes
- Eye protection

#### Repressurisation

## WARNING



**Repressurisation inside the compressor block after depressurisation has been performed!**

Risk of injury posed by pressurised components.

- Keep shut-off valves of the gas supply pipes shut during maintenance work.
- Keep ball valves in open position for pressure relief during maintenance work.

	<b>BUSHEHR MEG PLANT PROJECT</b>	Rev.: 00 Date: 08-11-2024
	Emergency instrument air compressor	

### 3.7.2.2 Purging the compressor block

Prior to commencing maintenance work the crank drive and the gas-carrying area of the compressor block must be purged (inerted) with purging gas.

The purging process must be performed for every compressor block individually.

#### System state

Component	State
Main switch	OFF and secured against reactivation
Compressor block	Depressurised

### 3.7.3 Maintenance plan

The sections that follow describe the maintenance work that will ensure that the system operates in an optimum way and free of faults.

#### Maintenance intervals

The intervals specified in the maintenance plan are recommendations which are influenced by the operating conditions (suction and final pressure), as well as the gas to be compressed (purity, humidity [humid, dry with dew point up to "bone dry"]).

The maintenance plan specifies the maintenance intervals for the first 8,000 operating hours.

After this point, the inspections are to be conducted in line with experience gained thus far regarding spare part wear.

#### Recommended first inspection

After **2,000 operating hours**, the first inspection of the compressor block should take place. The level of wear of the individual assemblies (valves, pistons, oil and gas gland) and the general condition of the compressor block is assessed.

#### Adapting maintenance intervals

If increased wear is identified during the regular inspections, then the maintenance intervals should be adapted appropriately to the actual incidence of wear in consultation with the manufacturer.

	<b>BUSHEHR MEG PLANT PROJECT</b>	Rev.: 00 Date: 08-11-2024
	Emergency instrument air compressor	

## Personnel

The definitions of personnel qualifications are described in section 2 of these operating instructions.

Symbol	Meaning
TP	Trained person
QP	Qualified specialist personnel with special training
E	Electrical specialist
I	Approved inspection body / for the inspection of competent personnel as per national regulations

	Actions required after operating hours:		Daily	50 to 500	2000	every 4,000	every 8,000	evrey 32,000	every 40,000
	Latest due after months:						every 12		every 60
Qualification	Component	Task							
TP	Operating parameters	Checking	▪		▪		▪		
TP	Compressor block	Check for noises and running behaviour	▪		▪		▪		
TP	Compressor block	Drain condensate	▪		▪		▪		
TP	Oil	Check fill level and condition	▪		▪		▪		
QP	Oil	Change			▪		▪		
QP	Oil filter	Change			▪		▪		
QP	Control unit, valve control unit	Checking			▪	▪	▪		
QP	Suction valve lifting	Lubrication			▪		▪		
QP	Suction and pressure valves *) / (**)	Inspection			▪		▪		
QP	Valve chambers	Inspection for deposits			▪		▪		
QP	Piston	Check ring grooves						▪	
QP	Piston and guide rings *) / (**)	Inspection			▪		▪		
QP	Piston rod	Inspection						▪	



**BUSHEHR MEG PLANT PROJECT**

Rev.: 00  
Date: 08-11-2024

Emergency instrument air compressor

In the event of questions regarding maintenance work and intervals, contact the manufacturer; see the contact data for customer services at the start of this section.

	Actions required after operating hours:		Daily	50 tot 500	2000	Every 4,000	Every 8.000	Every 32.000	Every 40.000
	Latest due after months:						Every 12		Every 60
Qualification	Component	Task							
QP	Gas gland *) / **)	Inspection			▪		▪		
QP	Non-return valve purging gas outlet / leakage gas, yoke	Checking					▪		
QP	Non-return valve for leakage gas return to suction side	Checking					▪		
QP	Cylinder liner	Inspection							▪
QP	Cylinder and Cylinder head	Check cooling water chambers and clean if necessary							▪
QP	Oil gland *) / **)	Inspection					▪		
QP	Crankcase	Remove covers and check bearings visually					▪		
QP	Screw connections of piston	Change screws							▪
QP	All bearings	Check visually							▪
QP	Crosshead	Inspection and change bolts							▪
QP	Oil pump	Check							▪
QP	Oil pressure regulator	Functional test							▪
QP	Screw connections	Re-tightening			▪		▪		▪



**BUSHEHR MEG PLANT PROJECT**

Rev.: 00  
Date: 08-11-2024

Emergency instrument air compressor

	Actions required after operating hours:		Daily	50 tot 500	2.000	Every 4.000	Every 8.000	Every 32.000	Every 40.000
	Latest due after months:						Every 12		Every 60
Qualification	Component	Task							
QP	V-belt (if installed)	Re-tightening		▪	▪	▪			
QP	V-belt (if installed)	Check; re-tighten or replace if necessary			▪	▪			
QP	Coupling (if installed)	Check wear			▪		▪		

\*) If increased wear is detectable during the inspection, the maintenance intervals are to be shortened. \*\*) If the components are heavily worn, they must be replaced.

# Bushehr MEG Plant Project

<b>VENDOR NAME</b>	: Airpack Nederland B.V
<b>EQUIPMENT DESCRIPTION</b>	: Nitrogen & Instrument Booster Package
<b>EQUIPMENT TAGNUMBER</b>	: 20-C-1002, 20-C-7080

## SECTION 4

### MAIN MOTOR



**Vendor doc. Number**

17811-20

**Vendor:**

Airpack Nederland B.V.

**P.O. NO.:**

MEG20-PO-BP303-021

**SHEET QTY: 10**



**BUSHEHR MEG PLANT PROJECT**

Rev.: 00  
Date: 08-11-2024

Main motor

4.	Main motor.....	3
4.1	Introduction.....	3
4.2	Shipment, storage and handling .....	3
4.3	Installation .....	4
4.4	Operation.....	8
4.5	Maintenance .....	9

	<b>BUSHEHR MEG PLANT PROJECT</b>	Rev.: 00 Date: 08-11-2024
	Main motor	

## 4. Main motor

### 4.1 Introduction

The installation, operation and maintenance of the motor must be always performed by personnel qualified for hazardous area motors using proper tools and methods and following the instructions contained in the documents supplied with the motor.

These motors can be used in hazardous areas with the following types of protection:

- Increased safety – “Ex be” or “Ex ec”
- Flammproof enclosure – “Ex db or “Ex eb”
- Protection by enclosure (combustible dust) – “Ex tb” or “Ex tc”

Details of motor marking may be found on nameplate and product certification, which is part of the documentation.

The objective of this manual is to provide important information, which must be considered during the shipment, storage, installation, operation and maintenance of the motor. Therefore, we advise to make a careful and detailed study of the instructions contained herein before performing any procedures on the motor.

#### **WARNING:**

Any component added to the motor by the user, for example, cable glands, thread plug, encoder, etc., must meet the type of protection of the enclosure, the “equipment protection levels” (EPL) and the degree of protection of the motor, according to the Standards indicated in the product certification.

Special conductions for safe use.

#### **WARNING:**

The sign “X” added to the certificate number, informed on the nameplate of the motor, indicates that the equipment demands special conditions for installation, operation and/or maintenance, being those described in the certificate and the motor documentation. For reference, the chapter Certificates lists the certificate numbers for each type of protection and their nameplate markings. The noncompliance with these requirements compromises the safety of the product and of the installation. The correct classification of the installation area and ambient characteristics is user’s responsibility. Electric motors have energized circuits and exposed rotating parts which may cause injuries to people.

### 4.2 Shipment, storage and handling

Check the motor conditions immediately after receiving. When any damage is noticed, this must be reported in writing to the transportation company, and immediately communicated to the insurance company and to WEG. In this case, no instalation job can be started before the detected problem has been solved. Check if the nameplate data matches the invoice data, the environmental conditions in which the motor will be instaled, the type of protection and EPL of the motor. If the motor is not immediately instaled, it must be stored in a clean and dry room protected against dust, vibrations, gases and corrosive agents, and with relative humidity not exceeding 60%. In order to prevent water condensation within the

motor during the storage period, it is recommended to keep the space heater ON (when supplied). In order to prevent oxidation of the bearings and ensure an even distribution of the lubricant, rotate the motor shaft at least once a month (at least five turns), always leaving it in a different position. For bearings with oil mist lubrication systems, the motor must be stored horizontally, independently from the mounting configuration, with ISO VG 68 oil in the bearing, and the shaft must be turned weekly. If motors with open bearings are stored longer than six months, the bearings must be relubricated with the amount of grease indicated on the nameplate before the commissioning of the motor. If the motors are stored for more than two years, it is recommended to change the bearings, or to remove, wash, inspect and relubricate them before the motor is started. After this storage period, it is also recommended to change the start capacitors of single-phase motors since they lose their operating characteristics.

**WARNING:**

Handle the motor always carefully to prevent impacts and damages to the bearings and always install the shaft transportation/locking device (if supplied) when transporting the motor. Use only the eyebolts to lift the motor. However, these eyebolts are designed for the motor weight only. Thus, never use these eyebolts to lift the motor with additional loads coupled to it. The lifting eyebolts of the terminal box, fan cover, etc., are intended to handle only these parts when disassembled from the motor.

Periodically and mainly before the initial start-up, measure the insulation resistance of the motor winding. Check the recommended values and the measuring procedures.

## 4.3 Installation

**WARNING:**

During the installation, the motors must be protected against accidental energization. Check the motor direction of rotation, turning it without load before it is coupled to the load.

Remove the transportation devices and shaft locking device (if supplied) before starting the motor installation. Motors must be only installed in places compatible with their mounting features and in applications and environments for which they are intended. It must be respected the type of protection and the EPL of the motor, according to the classification of the area where the motor will be installed. The motors with feet must be installed on bases duly planned in order to prevent vibrations and assure perfect alignment. The motor shaft must be properly aligned with the shaft of the driven machine. Incorrect alignment, as well as improper belt tension, will certainly damage the bearings, resulting in excessive vibrations and even causing the shaft to fail. The admissible shaft radial and axial loads indicated in the general manual of the website must be respected. Use flexible coupling whenever possible. When motors are fitted with oil lubricated bearings or oil mist lubrication systems, connect the cooling and lubrication tubes (where provided). For oil lubricated bearings, the oil level must be in the center of the sight glass.

Only remove the corrosion protection grease from the shaft end and flange immediately before the motor installation. Unless specified otherwise in the purchase order, motors are dynamically balanced with "half key" and without load (uncoupled). The driving elements,

	<b>BUSHEHR MEG PLANT PROJECT</b>	Rev.: 00
	Main motor	Date: 08-11-2024

such as pulleys, couplings, etc., must be balanced with "half key" before they are mounted on the shaft of the motors.

**WARNING:**

The motor must always be positioned so the drain hole is at the lowest position. "Open/closed" rubber drain plugs are delivered in closed position and must be opened periodically to allow the drainage of the condensed water. For environments with high water condensation levels and motor with degree of protection IP55, the drain plugs can be mounted in open position.

**WARNING:**

For motors with degree of protection IP56, IP65 or IP66, the drain plugs must remain at closed position, being opened only during the motor maintenance procedures. "Automatic" rubber drain plugs are designed for one use only and cannot be reused. If any drain plug is removed for any purpose, it must always be replaced by a new one.

The drain system of motors with Oil Mist lubrication system must be connected to a specific collection system. The drain plugs of explosion proof motors cannot be removed during installation and maintenance procedures. When provided with a breather-drain to certificates IECEx CSA 12.0005U, Sirra 12ATEX1245U, CSAE 21UKEX1299U, the motors are limited to Groups II and III, an ambient temperature of -55 °C to +50 °C for temperature class T5 and -55 °C to +80°C for temperature class T4 to T2. Do not cover or block the motor ventilation openings. Ensure a minimum clearance of ¼ of the diameter of the air intake of the fan cover from the walls. The air used for cooling the motor must be at ambient temperature, limited to the temperature range indicated on the motor nameplate (when not indicated, -20 °C to +40 °C must be considered). Motors installed outdoors or in the vertical position require the use of additional shelter to protect them from water; for instance, use of a drip cover. To prevent accidents, ensure that the grounding connection has been performed according to the applicable standards and that the shaft key has been securely fastened before the motor is started. Connect the motor properly to the power supply by means of safe and permanent contacts, always considering the data informed on the nameplate, such as rated voltage, wiring diagram, etc. When motors are supplied with flying leads, they must be suitably connected to an appropriate terminal box required for the use condition (type of protection). When using terminals, all wires that form the stranded cable must be fastened inside the sleeve. The insulation of the accessories cables must be kept up to 1 mm from the connector connection point.

	<b>BUSHEHR MEG PLANT PROJECT</b>	Rev.: 00
	Main motor	Date: 08-11-2024

When provided with terminal blocks marked with "W-A12", "W-B12 (160V)" or "W-B12 (500V)", the following characteristics must be respected:

Table 1 – Terminal block type designation

Characteristic	Terminal block type designation		
	W-A12	W-B12 (160V)	W-B12 (500V)
Voltage	Up to 160 V	Up to 160 V	Up to 500 V
Current	Max. 15A	Max. 15A	Max. 20A
Conductor cross section	0,3 to 2,5 mm <sup>2</sup>	0,3 to 4 mm <sup>2</sup>	0,3 to 4 mm <sup>2</sup>
Number of cables per terminal connection	2X1 mm <sup>2</sup>	2X1,5 mm <sup>2</sup>	2X1,5 mm <sup>2</sup>
Connection torque	0,5 to 0,7 Nm		
Service temperature	-20°C to +80°C		
ATEX marking/certificate	II 2G Ex eb IIC Gb / I M2 Ex eb I Mb / PTB 06 ATEX 1078 U		
IECEx marking/certificate	Ex eb IIC Gb / Ex eb I Mb / IECEx PTB 17.0014U		
UKEX marking/certificate	II 2G Ex eb IIC Gb / I M2 Ex eb I Mb / BAS21UKEX0454U		

When provided with an "Ex eb" terminal block according to certificates PTB 03 ATEX 1153 U/IECEx PTB 11.0088U / BAS21UKEX0453U, it is permitted a maximum of 2 (two) single-wire cables per terminal connection. For power cables and grounding system connections and terminal box assembly, the tightening torques indicated on Tables 2 and 3 must be respected.

Table 2 - Tightening torques for fixing elements [Nm]

Type of protection of enclosure	Component	M4	M5	M6	M8	M10	M12	M14	M16	M20	
Ex db Ex db eb	Terminal Box Cover	Class 8.8/12.9	-	3,5 to 5	6 to 12	14 to 30	28 to 60	45 to 105	75 to 110	115 to 170	230 to 330
		Class A2-70 / A4-70	-	3,5 to 5	6 to 8,5	14 to 19	28 to 40	45 to 60	75 to 100	115 to 170	225 to 290
Ex db	Grounding	1,5 to 3	3 to 5	5 to 10	10 to 18	28 to 40	45 to 70	-	115 to 170	-	
		1 to 1,5	2 to 4	4 to 6,5	6,5 to 9	10 to 18	15,5 to 30	-	30 to 50	50 to 75	
Ex db eb	Terminal block	1 to 1,5	2 to 4	4 to 6,5	6,5 to 9	5 to 9	10 to 15	-	20 to 30	-	
	Locking bolt for connection clamp	-	3 to 7	4 to 8	7 to 11	-	-	-	-	-	
	Locking bolt for power cables	-	-	-	2 to 6	6 to 10	-	-	-	-	
Ex ec Ex tb Ex tc Ex eb	Terminal box cover	-	3 to 5	4 to 8	8 to 15	18 to 30	25 to 40	30 to 45	35 to 50	-	
	Grounding	1,5 to 3	3 to 5	5 to 10	10 to 18	28 to 40	45 to 70	-	115 to 170	-	
	Terminal block	1 to 1,5	2 to 4	4 to 6,5	6,5 to 9	10 to 18	15,5 to 30	-	30 to 50	50 to 75	
	Terminal block fixing bolts	-	3 to 5	5 to 10	10 to 18	28 to 40	45 to 70	75 to 110	115 to 170	-	

Table 3 - Tightening torques for cable glands and plugs [Nm]

Thread	Material	M16	M20	M25	M32	M40	M50	M63	M80
Metric	Plastic	3 to 5	3 to 5	6 to 8	6 to 8	6 to 8	6 to 8	6 to 8	6 to 8
	Metallic	40 to 50	40 to 50	55 to 70	65 to 80	80 to 100	100 to 120	115 to 140	160 to 190
Thread	Material	NPT 1/2"	NPT 3/4"	NPT 1"	NPT 1 1/2"	NPT 2"	NPT 2 1/2"	NPT 3"	NPT 4"
NPT	Plastic	-	5 to 6	6 to 8	6 to 8	6 to 8	6 to 8	6 to 8	6 to 8
	Metallic	40 to 50	40 to 50	55 to 70	65 to 80	100 to 120	115 to 140	150 to 175	200 to 240

For power cables, switching and protection devices dimensioning, consider the rated motor current, the service factor, and the cable length, among others. For motors without terminal block, insulate the motor terminal cables by using insulating materials that are compatible with the insulation class informed on the nameplate. The minimum insulation distance between the non-insulated live parts themselves and between live parts and the grounding must respect the Table 4.

Table 4 - Minimum insulation distance (mm)

Voltage	Type of protection of the enclosure	
	Ex eb / Ex db eb	Ex ec / Ex db / Ex tb / Ex tc
U ≤ 440 V	6	4
440 < U ≤ 690 V	10	5,5
690 < U ≤ 1000 V	14	8
1000 < U ≤ 6900 V	60	45
6900 < U ≤ 11000 V	100	70
11000 < U ≤ 16500 V	-	105

**WARNING:**

Take the required measures in order to ensure the type of protection, the EPL and the degree of protection indicated on the motor nameplate:

- unused cable inlet holes in the terminal boxes must be properly closed with certified plugs;
- components supplied loose (for example, terminal boxes mounted separately) must be properly closed and sealed;

The cable entries used must be fitted with components (such as, cable glands and conduits) that meet the applicable standards and regulations for each country. For “Ex db” motors, the conduit entries are permitted only for electrical equipment of group II. The fixing elements mounted in the threaded through holes in the motor enclosure (for example, the flange) must be properly sealed, with the products listed in item 5, to ensure the degree of protection indicated on the motor nameplate.

The motor must be installed with overload protection devices. These protection devices can be integrated to the motor (such as thermistors in the windings) or external protection devices, where the motor load is monitored by the nominal current. For three-phase motors, it is recommended to install a phase failure protection device. Motors driven by variable frequency drives must have their winding thermal protections connected. For motors with a soft start supply, effective measures for limiting the temperature of the motor shall be provided by the installer according to the applicable installation standards. For other starting methods, the use of the thermal protections is optional. For “Ex ec”, “Ex db”, “Ex db eb”, “Ex tb” and “Ex tc” motors: all thermal protections (RTDs, bimetal thermal protectors and thermistors for stator protection) used in the motor protection circuit can be connected via a standard industrial controller located in a safe area. For “Ex eb” motors: all thermal protections (RTDs, bimetal thermal protectors and thermistors for stator protection) must be suitably certified Ex equipment or they are to be separately protected by the use of an intrinsic safety supply that ensures the minimum EPL Gb level of protection. Ensure the correct operation of the accessories (brake, encoder, thermal protection, forced ventilation, etc.) installed on the motor before it is started. The temperature limits for alarm and tripping of the thermal protection can be defined according to the application, however they may not exceed the values shown in Table 5.

Table 5 - Maximum temperature of actuation for thermal protections

Component	Classified area marked on nameplate	Classified area where product will be installed	Maximum operating temperature (°C)	
			Alarm	Tripping
Winding	Ex db	Ex db	130	150
	Ex ec	Ex ec	130	155
	Ex tb	Ex tb	120	140
	Ex tc	Ex tc		
	Ex eb	Ex eb	-	110
	Ex ec + Ex tc	Ex ec	140	155
		Ex tc	-	140
	Ex db + Ex tb	Ex db	140	150
Ex tb		-	140	
Bearings	All	All	110	120

**Notes:**

- 1) The quantity and type of thermal protections installed in the motor are informed in the additional nameplates included on it.
- 2) In case of calibrated thermal protection (for example, Pt-100), the monitoring system must be set at the operation temperature indicated on Table 5.

In “Ex eb” motors application, the thermal protection device, in case of overload or locked rotor, must actuate with time delay according to the current and track the external power cables. The “tE” time indicated in the motor nameplate can not be exceeded. The “Ex eb” motors, submitted to acceleration time conditions greater than 1,7 x “tE” time, must be protected with protection devices against overcurrent.

**WARNING:**

Motors fitted with Automatic Thermal Protectors will reset automatically as soon as the motor cools down. Thus, do not use motors with Automatic Thermal Protection in applications where the auto-resetting of this device may cause injuries to people or damage to equipment. If the Automatic Thermal Protector trips, disconnect the motor from the power supply and check the cause why the thermal protector trips.

For W60 motors with air-water heat exchanger, please see the nameplate at heat-exchanger. For information about the use of variable frequency drives, you must follow the instructions in the documents 50034162 (“Installation, Operation and Maintenance Manual of Electric Motors for Use in Explosive Atmospheres”) and 50029350 (“Induction motors fed by PWM frequency inverters”).

## 4.4 Operation

**WARNING:**

During operation, do not touch the non-insulated energized parts and never touch or stay too close to rotating parts. Ensure that the space heater is always OFF during the motor operation.

The rated performance values and the operating conditions are specified on the motor nameplate. The voltage and frequency variations of the power supply should never exceed the limits established in the applicable standards. Occasional different behavior during the normal operation (actuation of thermal protections, noise level, vibration level, temperature and current increase) must always be assessed by qualified personnel. Do not use roller

	<b>BUSHEHR MEG PLANT PROJECT</b>	Rev.: 00 Date: 08-11-2024
	Main motor	

bearings for direct coupling. Motors fitted with roller bearings require a minimum radial load to ensure a proper operation. For motors fitted with oil lubrication or oil mist systems, the cooling system must be ON even after the machine is OFF and until the machine is at complete standstill. In case of failure in the lubrication and/or cooling system, turn the motor OFF immediately. After complete standstill, the cooling and lubrication systems (if any exist) must be switched OFF and the space heaters (when supplied) must be switched ON. In case of doubts, turn the motor OFF immediately and contact Airpack Nederland BV.

## 4.5 Maintenance

### **WARNING:**

Before any service is performed, ensure that motor is at standstill, disconnected from the power supply and protected against accidental energization. Even when the motor is stopped, dangerous voltages may be present in space heater terminals. For motors with permanent magnet rotor (WQuattro and Magnet motors), the motor assembly and disassembly require the use of proper devices due to the attracting or repelling forces that occur between metallic parts. This maintenance must be only performed by an Airpack Nederland BV specifically trained for such an operation. People with pacemakers cannot handle these motors. The permanent magnets can also cause disturbances or damages to other electric equipment and components during maintenance. Motors with flameproof enclosures and Protection by enclosure (Ex t), wait at least 60 minutes for frame sizes IEC 71 up to 200 and NEMA 143/5 up to 324/6 and at

least 150 minutes for frames sizes IEC 225 up to 355 and NEMA 364/5 to 586/7 to open the terminal box and/or disassemble the motor. For easy removal of the terminal box cover for W22Xdb motors with terminal box integrated into the frame: remove a plug (if available) and then turn the terminal box cover before performing the removal procedure. Reinstall the plug according to item 3 (Installation) after completing the maintenance procedures.

For the W51 HD, W50 and HGF motor lines provided with axial fans, the motor and the axial fan have different markings for indicating the direction of rotation for prevent incorrect assembly. The axial fan must be assembled so that the indicative arrow for direction of rotation is always visible, viewing the non-drive end side. The marking indicated on the axial fan blade, CW for clockwise direction of rotation or CCW for counterclockwise direction of rotation, indicates the direction of rotation of the motor viewing the drive end side.

Motors with degree of protection greater than IP55 are supplied with a sealing product on joints and fixing bolts. Before assembly the components with machined faces (for example, terminal box cover of Flameproof motors), clean these surfaces and apply a new layer of this product.

For Flameproof motors joints only the following products can be used: Lumomoly PT/4 (manufacturer: Lumobras – for ambient temperature ranging from -20 °C to +80°C) or Molykote DC 33 (manufacturer: Dow Corning – for ambient temperature ranging from -55 °C to +80 °C). For motors with other types of protection, use Loctite 5923 (manufacturer: Henkel) on joints. For Flameproof motors, special care should be taken with the machined surfaces of the flame path. These surfaces must be free of burrs, scratches, etc. that reduce the flame path length and increase the gap. For any repair, contact Airpack Nederland BV. The gaps between terminal boxes and the respective terminal box covers should not exceed the values specified in Table 6.

	<b>BUSHEHR MEG PLANT PROJECT</b>	Rev.: 00
	Main motor	Date: 08-11-2024

Table 6 - Maximum gap between terminal box and terminal box cover for flameproof enclosures

Product line	Frame size	Flat joint		Cylindrical joint	
		Gap (max)	Lenght (min)	Gap (max)	Lenght (min)
W21Xdb	IEC 90 to 355 NEMA 143 to 586/7	0,05 mm	Under request	Not available	
W22Xdb	IEC 71 and 80	Not available		0,15 mm	12,5 mm
	IEC 90 to 355 NEMA 143 to 586/7	0,075 mm	6 mm	0,15 mm	19 mm

For terminal box cover mounting, please follow the tightening torques indicated on Table 2 for fixing bolts. In case of replacement of a fixing bolt, it is necessary to keep its dimensions and quality of material. For flameproof motors, the yield stress of the fastener elements of motor and terminal boxes enclosures must be at least equal to class 12.9 for carbon steel bolts and class A2-70 or A4-70 for stainless steel bolts. Motors which may have a potential risk of electrostatic charge accumulation, supplied duly identified, must receive proper cleaning and maintenance interventions, i.e. with the use of a damp cloth, avoiding electrostatic discharges. For Protection by Enclosure motors (groups I and/or II), the maximum permissible dust layer on the motor enclosure is five millimeters (5 mm). Regularly inspect the operation of the motor, according to its application, and ensure a free air flow. Inspect the seals, the fastening bolts, the bearings, the vibration and noise levels, the drain operation, etc.

# Bushehr MEG Plant Project

<b>VENDOR NAME</b>	: Airpack Nederland B.V
<b>EQUIPMENT DESCRIPTION</b>	: Nitrogen & Instrument Booster Package
<b>EQUIPMENT TAGNUMBER</b>	: 20-C-1002, 20-C-7080

## SECTION 5

### INTER / AFTER COOLER



Vendor doc. Number

17811-20

Vendor:

Airpack Nederland B.V.

P.O. NO.:

MEG20-PO-BP303-021

SHEET QTY: 10

	<b>BUSHEHR MEG PLANT PROJECT</b>	Rev.: 00
	Inter after cooler	Date: 08-11-2024

5 Inter and after cooler .....3

5.1 Introduction .....3

5.2 Cooling circuit .....4

	<b>BUSHEHR MEG PLANT PROJECT</b>	Rev.: 00
	Inter after cooler	Date: 08-11-2024

## 5 Inter and after cooler

### 5.1 Introduction

- These instructions describe how to handle the machine to ensure safe operation, optimum efficiency and long service life.
- Read this section before putting the machine into operation to ensure correct handling, operation and proper maintenance. The maintenance schedule is comprised of measures to keep the machine in good working condition.
- Keep instructions available for the operator and make sure that the machine is operated and maintenance is carried out in accordance with instructions. Record all operating data, maintenance performed, etc.
- Follow all relevant safety precautions.
- In all correspondence, mention the type and the serial number shown on the package nameplate.
- For all data not mentioned in the text, see the last page of this chapter, preventative maintenance chart and section A: General data.
- Airpack reserves the right to make changes at any time, without prior notice.

#### **IMPORTANT:**

- Never operate at higher pressure than the nominal one. The pressure can be found in section A: General Data.
- Never operate without the protectors of the moving parts in place.
- Never operate without safety devices. If dismantling any safety device for any reason, i.e. checking or repairing it, it is required that another be fitted before resuming operation.

#### **NOTE:**

Please note that the guarantee of our package is limited to an agreed length of time, however, serious damage appearing after the guarantee expires, which can be traced back to a mistake during manufacturing will be covered under the guarantee.

However, if 'non-genuine' spare parts are used in the package, lawfully, no personal damages or other damages can be accepted as any claim or guarantee. This statement applies during the guarantee period as well as after the guarantee has expired.

#### **Replacement part orders**

To avoid errors of interpretation, the following data must be indicated in any correspondence related to Airpack compressors as well as replacement part orders:

1. Airpack project reference no.
2. Package serial no.
3. Compressor model
4. Part number as stated in the spare parts list (for ordering replacement parts)

	<b>BUSHEHR MEG PLANT PROJECT</b>	Rev.: 00
	Inter after cooler	Date: 08-11-2024

Airpack reserves the right to modify the technical specification without prior notice and waives all legal responsibilities with respect to such modifications.

Any supplementary data concerning maintenance of your compressor can be obtained directly from:

Airpack Netherlands  
 Groeneweegje 25  
 4301 RN Zierikzee  
 Phone: (31) (0) 111-415455  
 E-mail: [airpack@airpack.nl](mailto:airpack@airpack.nl)  
 Webpage: [www.airpack.nl](http://www.airpack.nl)

---

#### **WARRANTY LIMITATIONS**

Please note that our packages are guaranteed for a limited period of time. However, serious damage appearing after the guarantee has expired which can be traced back to a mistake during manufacturing will be covered under our guarantee.



If spare parts are not ordered directly from Airpack Netherlands B.V., or modifications/changes are made to the machine without prior consent from Airpack Netherlands B.V., the guarantee will expire immediately. The maintenance log book must be accurate and Airpack certified maintenance must be performed according to the schedule. If correct, regular maintenance is not performed, any warranty of the package & its parts will be null and void. Airpack cannot legally be held responsible for problems, defects, or damage that may result.

Please be aware that disregarding the WARRANTY LIMITATIONS, may result in serious damage to the machine, your environment, and yourself!

**We Advise:** Always order spare parts from Airpack Netherlands B.V. to ensure the safety & guarantee of your package.

---

#### **General description**

## **5.2 Cooling circuit**

This Air Cooler requires no/little maintenance, other than regularly cleaning the cooler surfaces with air and a suitable solvent. For information regarding the solvents to be used please contact Airpack Netherlands B.V.

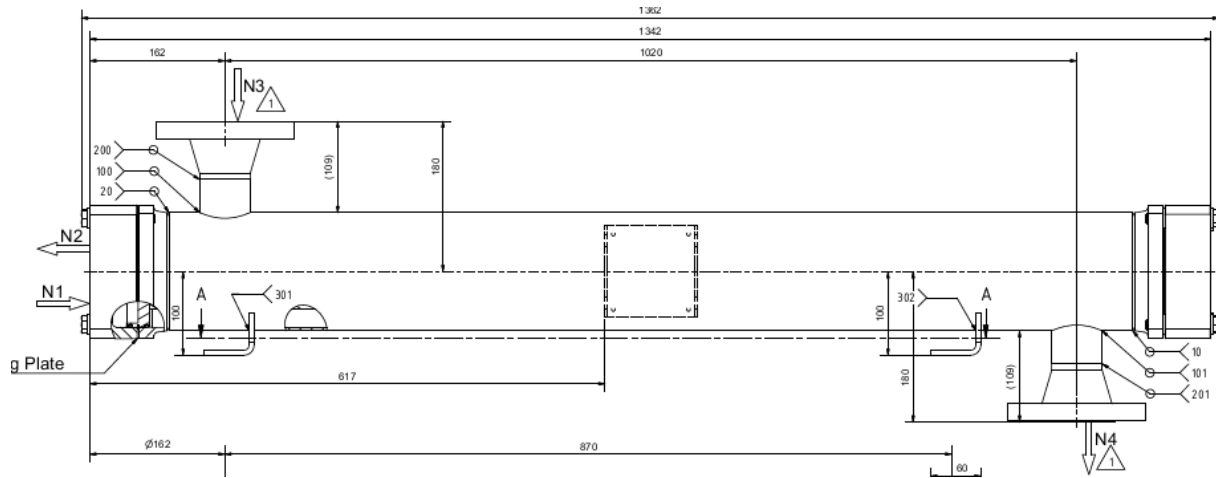

# Bushehr MEG Plant Project

VENDOR NAME	: Airpack Nederland B.V
EQUIPMENT DESCRIPTION	: Nitrogen & Instrument Booster Package
EQUIPMENT TAGNUMBER	: 20-C-1002, 20-C-7080

## SECTION 6

### DIFFERENTIAL PRESSURE GAUGE



Vendor doc. Number

17811-20

Vendor:

Airpack Nederland B.V.

P.O. NO.:

MEG20-PO-BP303-021

SHEET QTY: 03



## Table of Contents

6	Pressure Differential Gauge .....	3
6.1.	Introduction.....	3
6.2.	Precautions .....	3
6.3.	Certification .....	3
6.4.	Maintenance .....	3

## 6 Pressure Differential Gauge

### 6.1. Introduction

Incorrect use of pressure gauges can cause damage and injuries.

### 6.2. Precautions

### 6.3. Certification

CE mark



This device is designed to meet state-of-the-art safety requirements, has been tested and left the factory in a condition in which it is safe to operate. The device complies with the applicable standards and regulations as listed in the EC declaration of conformity and thus complies with the statutory requirements of the EC Directives.

### 6.4. Maintenance

- This instrument requires no special maintenance.
- In case of any default or issue, apply for assistance from Airpack BV. We will assist you with advice and service.
- The general safety of a facility often depends on the reliability of indications on the pressure gauges installed in the facility
- Any pressure gauge that seems to be giving false readings must be removed immediately, then tested. If the tests prove it is unreliable, it must be replaced with a new device.
- Periodic verifications should be carried out to check the accuracy of pressure gauges.
- Any pressure gauge considered to have been subjected to abnormal conditions of use (e.g. fire, wrong fluid, blow-out, etc.) must not be used.

# Bushehr MEG Plant Project

<b>VENDOR NAME</b>	: Airpack Nederland B.V
<b>EQUIPMENT DESCRIPTION</b>	: Nitrogen & Instrument Booster Package
<b>EQUIPMENT TAGNUMBER</b>	: 20-C-1002, 20-C-7080

## SECTION 7

### PRESSURE GAUGE



**Vendor doc. Number**

17811-20

**Vendor:**

Airpack Nederland B.V.

**P.O. NO.:**

MEG20-PO-BP303-021

**SHEET QTY: 04**



## Table of Contents

7	Pressure Gauge .....	3
7.1	Introduction.....	3
7.2	Precautions .....	3
7.3	Certification .....	4
7.4	Maintenance .....	4

## 7 Pressure Gauge

### 7.1 Introduction

This device may only be used to display the pressure of media which are not highly viscous, do not crystallize, do not cause chemical reactions and which are compatible with the materials of the device under the specific measuring conditions (e.g. temperature, atmosphere, immunity of the material against the measured medium, etc.). The pressure of the medium must never exceed the full scale value of the pressure gauge. Any use other than that explicitly outlined in this instruction manual is not permitted.

This device may only be mounted, commissioned, operated, maintained, shut down and disposed of by qualified, specially trained staff.

### 7.2 Precautions

#### WARNING

Gases or liquids under high pressure pose a greater danger. Safety pressure gauges with blow-out devices (e.g. blow-out rear walls) should be used as a precaution in the event of leaks or bursting parts under pressure, to protect persons in front of the window of the pressure gauge from escaping medium or flying parts.

- The pressure of the medium must never exceed the full scale value of the pressure gauge.
- The pressure gauges may only be used in accordance with the temperature ranges specified.
- The pressure gauges must never be used as a part of an out-of-range safety system to protect against parameters exceeding permissible limit values (equipment parts with safety function).
- **WARNING:** pressure pulses can cause considerable shortening of the operating life of pressure gauges.

Overloads cause tension in the elastic measuring element which decreases its service life and deteriorates the measuring accuracy. You should always use a pressure gauge whose full scale value is greater than the maximum static pressure which makes the device less sensitive to overload and load changes.

**NOTE:** If for operational reasons, the range must be smaller than the maximum operating pressure, it is possible to install an overload protection device to protect the pressure gauge from damage. However, highly viscous or polluted media may have an adverse effect on the protection device or even make it ineffective.

## 7.3 Certification

CE mark



This device is designed to meet state-of-the-art safety requirements, has been tested and left the factory in a condition in which it is safe to operate. The device complies with the applicable standards and regulations as listed in the EC declaration of conformity and thus complies with the statutory requirements of the EC Directives.

## 7.4 Maintenance

Using unsuitable spare parts and accessories may cause damage to the product. Use only genuine Airpack B.V. spare parts and accessories!

Pressure gauges are generally low-maintenance. Routine checks of the components and verification of accuracy should be performed. The general safety of a facility often depends on the reliability of indicators on the pressure gauges installed in the facility. Any pressure gauge that seems to be giving false readings must be removed immediately and tested. If the test proves it unreliable, it must be replaced with a new device. Any pressure gauge thought to have been exposed to abnormal conditions (fire, incorrect fluid, blow-out, etc.) may not be used!

Pressure gauges may only be repaired by the manufacturer. Prior to returning a pressure gauge to the manufacturer, you must completely remove the medium from the device, especially if the medium can be harmful (i.e. poisonous, caustic, flammable, etc.). When returning a device, it must be accompanied by a declaration that proper procedure has been followed and it does not pose any danger.

# Bushehr MEG Plant Project

<b>VENDOR NAME</b>	: Airpack Nederland B.V
<b>EQUIPMENT DESCRIPTION</b>	: Nitrogen & Instrument Booster Package
<b>EQUIPMENT TAGNUMBER</b>	: 20-C-1002, 20-C-7080

## SECTION 8

### TEMPERATURE GAUGE



**Vendor doc. Number**

17811-20

**Vendor:**

Airpack Nederland B.V.

**P.O. NO.:**

MEG20-PO-BP303-021

**SHEET QTY: 04**



## Table of Contents

8	Temperature gauge .....	3
8.1	Introduction.....	3
8.2	Precautions .....	3
8.3	Certification .....	3
8.4	Maintenance .....	3

## 8 Temperature gauge

### 8.1 Introduction

### 8.2 Precautions

Thermometers operating below 0°C (32°F) must have a perfectly tight case to prevent entrance of moisture. "Hermetically sealed" thermometers are closed off in a dry, warm atmosphere and need no maintenance. If "bayonet ring type thermometers" show for any reason sign of stickiness when indicating a low temperature they should be brought to a dry, warm location and allow them to dry out for 24 to 48 hours with an open case. Afterwards, close the cases carefully and reinstall them.

A temperature indicator should be installed in a vibration free area. The instrument might exhibit excessive wear on the bearing surfaces of the movement. If an installed gauge fails and exhibits these symptoms it is almost certain that the wrong type of instrument has been used for that particular application and it is essential that the manufacturer is consulted.

### 8.3 Certification

CE mark



This device is designed to meet state-of-the-art safety requirements, has been tested and left the factory in a condition in which it is safe to operate. The device complies with the applicable standards and regulations as listed in the EC declaration of conformity and thus complies with the statutory requirements of the EC Directives.

This temperature gauge meets the statutory requirements of the following EC Directives:

### 8.4 Maintenance

The instruments need little or no maintenance. But be sure that the case is closed at all times, so that no moisture or dirt can enter the case. If the thermometer is used with a medium that may harden and build up, the thermometer should be occasionally the stem cleaned.

The function of the gauge does not require any special maintenance procedures but frequent checks must be made to ensure that the instrument is still working correctly and



accurately. Any shift in temperature readings greater than twice the tolerance of the instrument must be investigated and the gauge immediately replaced if it is faulty.

The repair and recalibration of the instrument should be undertaken only by competent personnel who have at their disposal the necessary facilities.

# Bushehr MEG Plant Project

<b>VENDOR NAME</b>	: Airpack Nederland B.V
<b>EQUIPMENT DESCRIPTION</b>	: Nitrogen & Instrument Booster Package
<b>EQUIPMENT TAGNUMBER</b>	: 20-C-1002, 20-C-7080

## SECTION 9

### THERMOWELL



**Vendor doc. Number**

17811-20

**Vendor:**

Airpack Nederland B.V.

**P.O. NO.:**

MEG20-PO-BP303-021

**SHEET QTY: 05**



## Table of Contents

9	Thermowell.....	3
9.1	General.....	3
9.2	Safety .....	3
9.3	Mounting .....	4
9.4	Maintenance .....	5

## 9 Thermowell

### 9.1 General

Thermowells are used to protect temperature sensors from the process conditions. Furthermore, thermowells enable the removal of the temperature sensor without having to shut down the process; and they guard against damage to either the environment or to personnel, which might be caused by escaping process media.

The thermowell has been designed and built solely for the intended use described here, and may only be used accordingly.

The technical specifications contained in these operating instructions must be observed. Should the thermowell be improperly handled or operated outside of its technical specifications, it has to be inspected immediately.

### 9.2 Safety

Before installation, commissioning and operation ensure that the appropriate thermowell has been selected in terms of measuring range, design and specific measuring conditions.

Before installation, commissioning and operation ensure that the thermowell material used is chemically resistant / neutral to the medium being measured and that it withstands the mechanical stresses from the process.

Non-observance can result in serious injury and/or damage to equipment.

For hazardous media such as oxygen, acetylene, flammable or toxic gases or liquids, and refrigeration plants, compressors, etc., in addition to all standard regulations, the appropriate existing codes or regulations must also be followed. Make sure that the thermowell is sufficiently earthed.

Residual media on dismantled thermowells can result in a risk to persons, the environment and the equipment. Take sufficient precautionary measures.

## 9.3 Mounting

During mounting (especially with ceramic thermowells) the thermowells should not be subjected to thermal shocks or mechanical impacts.

Insert the thermowell into the process adapter without forcing or damaging it. The thermowell must not be bent or altered in order to mount it.

The exception is the retrospective machining of the support ring in order that the thermowell is supported free of play within the nozzle ("interference fit"). The retrospective adjustment of a support ring with a loose fit is not permissible. In general, thermowells with a support ring are not recommended within ASME PTC 19.3 TW 2010 and are outside of the scope of the standard.

It is recommended to mount the temperature measuring instrument into the thermowell using a suitable sealing material to avoid, for example, humidity ingress.

In general, the tip of the thermowell should be placed in the middle third of the pipe, though the position may differ in special cases. It must be ensured that the measuring element (Pt100, thermocouple, bimetal, etc.) is completely exposed to the medium and is not shielded by the flange stubs. If, as a result of a small pipe diameter, this cannot be ensured, a pipe expansion can be inserted around the measuring point.

**Flanged thermowells:** The flange dimensions of the thermowell must match those of the mating flange on the process side. The seals used must be suitable for the process and the flange geometries (cross-check the project specification). The correct tightening torques and suitable tools (e.g. spanner) should be used for installation. For thermowells with a collar, make sure that it matches the inner diameter of the coupling and is supported by it. In the case of an interference collar, they should be adapted to the inner diameter of the coupling.

The insertion length and the diameter of the thermowell are dependent on the process conditions, especially on the flow rate of the measured medium.

## 9.4 Maintenance

### **Dismounting**

Only disconnect thermowells once the system has been depressurized!

### **Risk of burns!**

Let the instrument cool down sufficiently before dismounting it!

When dismounting it, there is a risk that dangerously hot pressure media may escape.

Residual media on dismantled thermowells can result in a risk to persons, the environment and equipment. Take sufficient precautionary measures.

In general, thermowells are maintenance-free.

We recommend a visual check of the thermowell for leaks and damages at regular intervals.

Make sure that the seal is in perfect condition!

# Bushehr MEG Plant Project

<b>VENDOR NAME</b>	: Airpack Nederland B.V
<b>EQUIPMENT DESCRIPTION</b>	: Nitrogen & Instrument Booster Package
<b>EQUIPMENT TAGNUMBER</b>	: 20-C-1002, 20-C-7080

## SECTION 10

### PRESSURE TRANSMITTER



Vendor doc. Number

17811-20

Vendor:

Airpack Nederland B.V.

P.O. NO.:

MEG20-PO-BP303-021

SHEET QTY: 05



## Table of Contents

10	Pressure transmitter.....	3
10.1	Introduction.....	3
10.2	Precautions.....	3
10.3	Certification.....	4
10.4	Maintenance .....	5

## 10 Pressure transmitter

### 10.1 Introduction

Your Pressure Transmitter was precisely calibrated at the factory before shipment. To ensure both safety and efficiency, please read this manual carefully before you operate the instrument.

This pressure transmitter is for measuring pressure and level. The manufacturer accepts no liability for damages resulting from incorrect use or use other than that designated.

The device has been designed to operate safely in accordance with current technical, safety and EU standards. If installed incorrectly or used for applications for which it is not intended, however, it is possible that application-related dangers may arise (e.g. product overflow due to incorrect installation or calibration). For this reason, the instrument must be installed, connected, operated and maintained according to the instructions in this manual: personnel must be authorized and suitably qualified to operate and maintain equipment. The manual must be read and understood, and the instructions followed. Modifications and repairs to the device are permissible only if they are expressly approved in the manual. Pay particular attention to the technical data on the nameplate.

Assembly, electrical connection, commissioning, and maintenance of this transmitter may only be done by authorized specialists. Qualified persons are experienced in the assembly, electrical connection, commissioning, and operation of the transmitter and hold the necessary qualifications to complete such work.

The device must be stored in a dry, clean area, protected against damage from impact.

### 10.2 Precautions

---

**DANGER**

To prevent possible explosions and to maintain explosion proof, dust-ignition proof protection, observe all applicable wiring practices. Plug unused conduit opening with the provided metal pipe plug, which engages a minimum of five full threads.

Explosions can result in death or serious injury.

- Do not remove the transmitter covers in explosive environments when the circuit is live.
- Both transmitter covers must be fully engaged to meet explosion-proof requirements.
- Before connecting a communicator in an explosive atmosphere, make sure the instruments in the loop are installed in accordance with intrinsically safe or non-incentive **filed** wiring practices.

- Verify that the operating atmosphere of the transmitter is consistent with the appropriate hazardous locations certifications.
- Electrical shock can result in death or serious injury. Avoid contact with the leads and terminals!

**NOTE**

Airpack recommends the use of transient/surge protection in installations prone to high levels of electrical transients and surges.

**NOTE:**

Make sure all electrical installation is in accordance with national and local code requirements.

- With high process temperatures, care must be taken not to burn yourself by touching the instrument or its casing.
- Never loosen the process connector nuts when the instrument is installed in a process. This can lead to a sudden, explosive release of process fluids.
- When draining condensate from the pressure detector section, take appropriate precautions to prevent the inhalation of harmful vapours and the contact of toxic process fluids with the skin or eyes.
- When removing the instrument from a hazardous process, avoid contact with the fluid and the interior of the meter.
- All installation shall comply with local installation requirements and the local electrical code.

## 10.3 Certification

CE mark



This device is designed to meet state-of-the-art safety requirements, has been tested and left the factory in a condition in which it is safe to operate. The device complies with the applicable standards and regulations as listed in the EC declaration of conformity and thus complies with the statutory requirements of the EC Directives.

This pressure transmitter meets the statutory requirements of the following EC Directives:

## 10.4 Maintenance

Wait 10 minutes after power is turned off, before opening covers.

Grounding is always required for the proper operation of transmitters. Follow the domestic electrical requirements as regulated in each country.

---

**WARNING:**

- Never loosen the process connector bolts when an instrument is installed in a process. The device is under pressure, and a loss of seal can result in a sudden and uncontrolled release of process fluid.
  - When draining toxic process fluids that have condensed inside the pressure detector, take appropriate steps to prevent the contact of such fluids with the skin or eyes and the inhalation of vapours from these fluids.
- 

---

**DANGER**

For non-intrinsically safe installations, to prevent a potential explosion in a division 1 hazardous area, de-energize transmitters before you remove threaded housing covers. Failure to comply with this warning could result in an explosion resulting in severe injury or death.

---

Care should be taken to prevent the build-up of drift dust or other material on the display glass and name plate. When performing maintenance, a soft and dry cloth should be used.

Parts replacement is generally limited to the electronics module assembly, housing assembly, sensor assembly, terminal block assembly, cover O-rings, and optional display. Replacements equipment or spare parts not approved by Airpack B.V. for use as spare parts could reduce the pressure retaining capabilities if the transmitter and may render the instrument dangerous.

# Bushehr MEG Plant Project

<b>VENDOR NAME</b>	: Airpack Nederland B.V
<b>EQUIPMENT DESCRIPTION</b>	: Nitrogen & Instrument Booster Package
<b>EQUIPMENT TAGNUMBER</b>	: 20-C-1002, 20-C-7080

## SECTION 11

### TEMPERATURE TRANSMITTER



Vendor doc. Number

17811-20

Vendor:

Airpack Nederland B.V.

P.O. NO.:

MEG20-PO-BP303-021

SHEET QTY: 05



## Table of Contents

11	Temperature transmitter .....	3
11.1	Introduction .....	3
11.2	Precautions.....	4
11.3	Certification.....	4
11.4	Maintenance .....	5

# 11 Temperature transmitter

## 11.1 Introduction

Before handling the temperature transmitter, it is absolutely imperative that users of this equipment read and observe the safety instructions mentioned in each section of the manual in order to ensure the protection and safety of operators, the transmitter itself and the system containing the transmitter. Airpack B.V. cannot be held liable for any damage or accidents due to actions or operation that does not adhere to the guidelines established in the manual, operation instructions, safety instructions, etc.

This device is a universal and configurable temperature field transmitter for resistance thermometers (RTD), thermocouples (TC) and resistance and voltage transmitters. The device is designed for installation in the field.

The manufacturer does not accept liability for damage caused by improper or non-designated use.

Among all factors, which may affect transmitter accuracy, environmental conditions are the most difficult to control. There are, however, ways of reducing the effects of temperature, humidity and vibration. Temperature fluctuation effects can be minimized by locating the transmitter in areas protected from extreme environmental changes.

In warm environments, the transmitter should be installed to avoid direct exposure to the sun. Installation close to lines and vessels subjected to high temperatures should also be avoided. For temperature measurements, sensors with cooling-neck can be used or the sensor can be mounted separated from the transmitter housing.

Use of sunshades or heat shields to protect the transmitter from external heat sources should be considered, if necessary.

Humidity is fatal to electronic circuits. In areas subjected to high relative humidity, the O-rings for the electronics cover must be correctly placed. Removal of the electronics cover in the field should be reduced to the minimum necessary because every time it is removed, the circuits are exposed to the humidity. The electronic circuit is protected by a humidity proof coating, but frequent exposures to humidity may affect the protection provided. It is also important to keep the covers tightened in place. Every time they are removed, the threads are exposed which leads to corrosion, since these parts cannot be protected by painting., code-approved sealing methods on conduit entering the transmitter should be employed. Contact Airpack B.V. for more information.

Measurement error can be decreased by connecting the sensor as close to the transmitter as possible and using proper wires (see Section II, Operation).

## 11.2 Precautions

### CAUTION:

The products described in this document are NOT designed for nuclear-qualified applications. Using this product in applications that require nuclear-qualified hardware or products may cause inaccurate readings and will void the guarantee as it goes against the intended use.

### WARNING:

Explosions may result in death or serious injury.

- Do not remove the instrument cover in explosive atmospheres when the circuit is live.
- Before connecting a field communicator in an explosive atmosphere, make sure the instruments in the loop are installed in accordance with intrinsically safe or non-incentive field wiring practices.
- Both transmitter covers must be fully engaged to meet explosion-proof requirements.
- Electrical shock could cause death or serious injury. If the sensor is installed in a high-voltage environment and a fault or installation error occurs, high voltage may be present on transmitter leads and terminals.
- Use extreme caution when making contact with the leads and terminal.
- Process leaks could result in death or serious injury:
- Install and tighten thermowells or sensors before applying pressure or process leakage may result.
- Do not remove the thermowells while in operation. Removing them may cause process fluid leaks.

## 11.3 Certification

CE mark



This device is designed to meet state-of-the-art safety requirements, has been tested and left the factory in a condition in which it is safe to operate. The device complies with the applicable standards and regulations as listed in the EC declaration of conformity and thus complies with the statutory requirements of the EC Directives.

This temperature transmitter meets the statutory requirements of the following EC Directives:

## 11.4 Maintenance

The transmitter has no moving parts and requires a minimum amount of scheduled maintenance. The transmitter features a modular design for easy maintenance. If a malfunction is suspected, check for an external cause before performing the diagnostics.

In general, it is recommended that the end user do not try to repair printed circuit boards. Instead he should have spare circuit boards, which may be ordered from Airpack B.V.

# Bushehr MEG Plant Project

<b>VENDOR NAME</b>	: Airpack Nederland B.V
<b>EQUIPMENT DESCRIPTION</b>	: Nitrogen & Instrument Booster Package
<b>EQUIPMENT TAGNUMBER</b>	: 20-C-1002, 20-C-7080

## SECTION 12

### FLOW TRANSMITTER



**Vendor doc. Number**

17811-20

**Vendor:**

Airpack Nederland B.V.

**P.O. NO.:**

MEG20-PO-BP303-021

**SHEET QTY: 03**



## Table of Contents

12	Flow Transmitter .....	3
12.1.	Introduction.....	3
12.2.	Precautions .....	3
12.3.	Certification .....	3
12.4.	Maintenance .....	3

## 12 Flow Transmitter

### 12.1. Introduction

**CAUTION:**

It is prohibited by law for the user to modify flameproof instruments. It is not permitted to add or remove indicators.

### 12.2. Precautions

**NOTE:** The manufacturer shall not be liable for any damages resulting from improper use or deployment contrary to prescribed purpose.

**IMPORTANT:** Meters may only be installed, commissioned, operated and maintained by properly trained and authorized personnel.

**WARNING:**

For devices used in hazardous areas, additional safety notes apply; please refer to the Appendix.

- A sufficient perimeter around the transmitter must be kept to allow for servicing.
- Protect the transmitter from direct exposure to the sun.

### 12.3. Certification

CE mark



This device is designed to meet state-of-the-art safety requirements, has been tested and left the factory in a condition in which it is safe to operate. The device complies with the applicable standards and regulations as listed in the EC declaration of conformity and thus complies with the statutory requirements of the EC Directives.

### 12.4. Maintenance

**WARNING:** All work on the flowmeter electric system may only be carried out by a trained electrician or engineer. The regional occupational health and safety directives and regulations must be observed without exception.

**WARNING:**

All work on the electrical connections may only be carried out with the power disconnected. Take note of the voltage data on the nameplate!

# Bushehr MEG Plant Project

<b>VENDOR NAME</b>	: Airpack Nederland B.V
<b>EQUIPMENT DESCRIPTION</b>	: Nitrogen & Instrument Booster Package
<b>EQUIPMENT TAGNUMBER</b>	: 20-C-1002, 20-C-7080

## SECTION 13

### VIBRATION SWITCH



**Vendor doc. Number**

17811-20

**Vendor:**

Airpack Nederland B.V.

**P.O. NO.:**

MEG20-PO-BP303-021

**SHEET QTY: 03**



## Table of Contents

13	Vibration switch .....	3
13.1	Introduction .....	3
13.2	Precautions.....	3
13.3	Certification.....	3
13.4	Maintenance .....	3

## 13 Vibration switch

### 13.1 Introduction

The vibration switch is a simple mechanical device, operated by balancing magnetic attraction on a metal ball, against acceleration forces produced by surrounding vibrations. The switch is mounted vertically with the ball restrained in a conical seat by a permanent magnet. When the ball experiences sufficient acceleration, (excessive vibration of the machine), it breaks free, falls and operates a Microswitch. The Microswitch is connected to the electrical interface and causes a machine shutdown.

### 13.2 Precautions

### 13.3 Certification

CE mark



This device is designed to meet state-of-the-art safety requirements, has been tested and left the factory in a condition in which it is safe to operate. The device complies with the applicable standards and regulations as listed in the EC declaration of conformity and thus complies with the statutory requirements of the EC Directives.

### 13.4 Maintenance

No maintenance is required on the switch after installation and set-up. Periodic service functional testing is recommended by reducing the set level to effect switch operation. No repairs are to be undertaken – for replacement parts, or questions contact Airpack.

# Bushehr MEG Plant Project

<b>VENDOR NAME</b>	: Airpack Nederland B.V
<b>EQUIPMENT DESCRIPTION</b>	: Nitrogen & Instrument Booster Package
<b>EQUIPMENT TAGNUMBER</b>	: 20-C-1002, 20-C-7080

## SECTION 14

### SOLENOID VALVE



**Vendor doc. Number**

17811-20

**Vendor:**

Airpack Nederland B.V.

**P.O. NO.:**

MEG20-PO-BP303-021

**SHEET QTY: 04**



## Table of Contents

14	Solenoid valve .....	3
14.1	Introduction .....	3
14.2	Precautions.....	3
14.3	Certification.....	3
14.4	Maintenance .....	3

## 14 Solenoid valve

### 14.1 Introduction

### 14.2 Precautions

---

**WARNING**

It is not permitted to have the solenoid cover removed by an unauthorized person. Solenoid housing constitutes a tight tolerance flame path of the flameproof solenoid. When removing or re-assembling the solenoid cover, extreme care should be taken to avoid any damage to either the spigot or the bore. Do not paint these surfaces, however, some grease or lubricant may be sparingly applied.

---

### 14.3 Certification

CE mark



This device is designed to meet state-of-the-art safety requirements, has been tested and left the factory in a condition in which it is safe to operate. The device complies with the applicable standards and regulations as listed in the EC declaration of conformity and thus complies with the statutory requirements of the EC Directives.

---

**CAUTION**

Electrical operations must be within the range stated on the nameplate. Failure to stay within the electrical range of the coil rating results in damage to or premature failure of the coil. It will also invalidate the approval.

---

### 14.4 Maintenance

---

**CAUTION:**

Before servicing the solenoid valve, turn off electrical power, depressurize valve, and vent fluid to a safe area. Do not open the solenoid if energized recently, delay opening for 30 minutes. Solenoid must be fully reassembled as the housing and internal parts complete the magnetic circuit.

In case of any replacement of parts by the used, the quality of the final product cannot be guaranteed. Incorrect assembly will invalidate the approval.

---



We recommend to periodically check that components are operating correctly, look for excessive wear or damage and clean parts. The frequency of checks needed depends on the type of fluids used, the operating conditions, and environmental factors. Depending on the device used, spare part kits are available.

Before any maintenance work is done, **power off and depressurise** the component, apparatus, machinery or installation to prevent any unauthorised intervention. Make sure that the component and the surrounding environment are clean. If problems arise during maintenance, please contact Airpack B.V.

# Bushehr MEG Plant Project

<b>VENDOR NAME</b>	: Airpack Nederland B.V
<b>EQUIPMENT DESCRIPTION</b>	: Nitrogen & Instrument Booster Package
<b>EQUIPMENT TAGNUMBER</b>	: 20-C-1002, 20-C-7080

## SECTION 15

### Y-STRAINER



**Vendor doc. Number**

17811-20

**Vendor:**

Airpack Nederland B.V.

**P.O. NO.:**

MEG20-PO-BP303-021

**SHEET QTY: 04**



## Table of Contents

15	Y-strainer.....	3
15.1.	Precautions .....	3
15.2.	Certification .....	3
15.3.	Maintenance activities .....	4

## 15 Y-strainer

### 15.1. Precautions

---

**WARNING:**

INCORRECT OR IMPROPER USE OF THIS PRODUCT CAN CAUSE SERIOUS PERSONAL INJURY AND PROPERTY DAMAGE.

---

---

**WARNING**

Devices from the manufacturer may only be installed, commissioned, operated and maintained by properly trained and authorized personnel.

This document is provided to help you establish operating conditions, which will permit safe and efficient use of this device.

---

### 15.2. Certification

CE mark



This device is designed to meet state-of-the-art safety requirements, has been tested and left the factory in a condition in which it is safe to operate. The device complies with the applicable standards and regulations as listed in the EC declaration of conformity and thus complies with the statutory requirements of the EC Directives.

This solenoid valve meets the statutory requirements of the following EC Directives:

## 15.3. Maintenance activities

### CAUTION:

Please ensure to depressurize the system before conducting any maintenance to this Y-strainer.

Maintenance on the Y-strainers is only to be done on the stand-by filters or package.

If properly installed, y strainers require very little monitoring. However, it is important to keep track of the pressure to make sure that the equipment does not get too full. This would cause the screen to break and it would need to be replaced. If the screen fails, it could damage the entire system which would quickly become a very costly problem. The filter can be easily accessed which makes for a simple cleaning process overall. Remember to close off the valve connections on either side of the y strainer before starting to clean and relieve pressure. From there, empty out the unwanted material and debris. Finally, clean the mesh filter and replace.

### Y Strainer

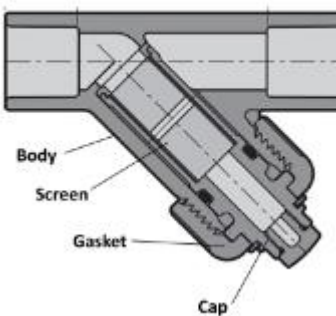

Flow direction

# Bushehr MEG Plant Project

VENDOR NAME	: Airpack Nederland B.V
EQUIPMENT DESCRIPTION	: Nitrogen & Instrument Booster Package
EQUIPMENT TAGNUMBER	: 20-C-1002, 20-C-7080

## SECTION 16

### BALL VALVE



Vendor doc. Number

17811-20

Vendor:

Airpack Nederland B.V.

P.O. NO.:

MEG20-PO-BP303-021

SHEET QTY: 05



## Table of Contents

16	Ball valve .....	3
16.1.	Introduction .....	3
16.2.	Precautions .....	3
16.3.	Certification .....	4
16.4.	Maintenance .....	4

## 16 Ball valve

### 16.1. Introduction

This valve gets its name from the ball that rotates to open and close the valve. Ball valves are used in situations where tight shut-off is required.

**NOTE:**

This valve is intended for a specific range of pressures, temperatures and other application specifications.

Applying different pressures and temperatures to the valve could result in damage to the valve, malfunction of the control valve, or loss of control of the process. Do not expose this product to service conditions or variables other than those for which the product was intended. If you are not sure what these conditions are you should contact Airpack for complete specifications and clarification. Provide the product serial number (shown on the nameplate) and all other pertinent information.

### 16.2. Precautions

**WARNING:**

INCORRECT OR IMPROPER USE OF THIS PRODUCT CAN CAUSE SERIOUS PERSONAL INJURY AND PROPERTY DAMAGE.

**WARNING**

Devices from the manufacturer may only be installed, commissioned, operated and maintained by properly trained and authorized personnel.

This document is provided to help you establish operating conditions, which will permit safe and efficient use of this device.

## 16.3. Certification

CE mark



This device is designed to meet state-of-the-art safety requirements, it has been tested and left the factory in a condition in which it is safe to operate. The device complies with the applicable standards and regulations as listed in the EC declaration of conformity and thus complies with the statutory requirements of the EC Directives.

## 16.4. Maintenance

**ATTENTION:** during maintenance- or repair work- the valve must be completely pressure released and discharged! Disconnect all pneumatic, hydraulic and electric tubes/lines and protect them against unintentional insertion process.

Provided that competent, trained personnel and the correct original spare parts are available, maintenance and revision of valve(s) can be carried out on site. The manufacturer's personnel are also available upon request.

### Maintenance & valve service

Ball valves do not require a lot of maintenance. However, solid or liquid particles in the gas flow may cause wear or mechanical damage to the valve plate or other valve parts.

In order to ensure a long lifetime and faultless operation, ball valves should be regularly inspected for service:

- a. Clean gas or clean air: every 16,000 to 24,000 service hours
- b. Slightly polluted gas: every 6,000 to 12,000 service hours
- c. Heavily polluted gas: every 2,000 service hours

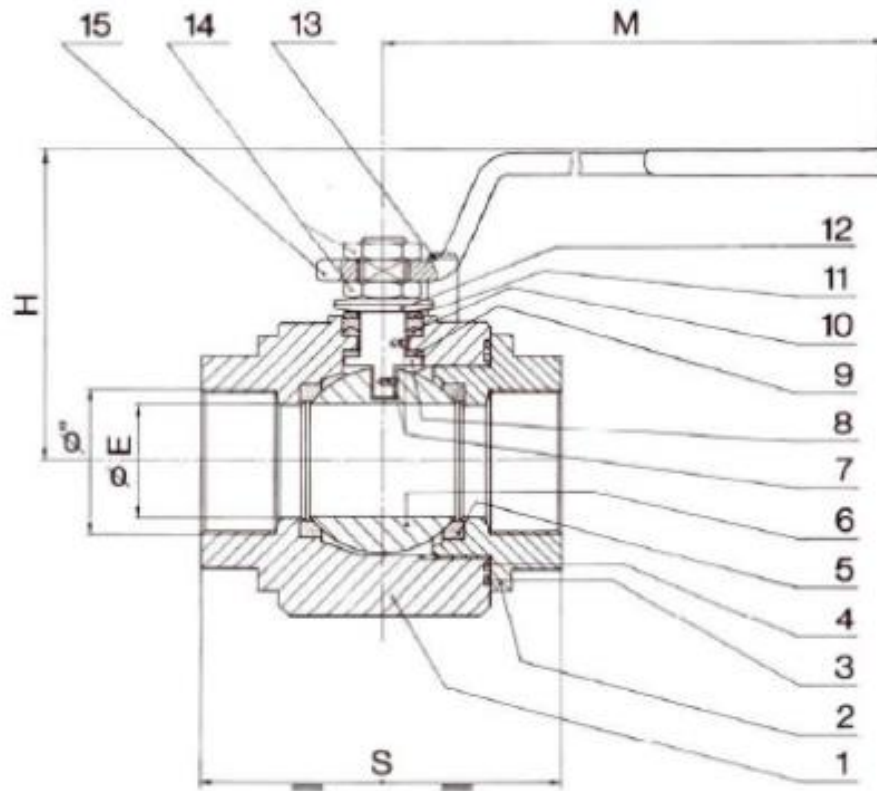

# Bushehr MEG Plant Project

<b>VENDOR NAME</b>	: Airpack Nederland B.V
<b>EQUIPMENT DESCRIPTION</b>	: Nitrogen & Instrument Booster Package
<b>EQUIPMENT TAGNUMBER</b>	: 20-C-1002, 20-C-7080

## SECTION 17

### PNEUMATIC ACTUATED VALVE



Vendor doc. Number

17811-20

Vendor:

Airpack Nederland B.V.

P.O. NO.:

MEG20-PO-BP303-021

SHEET QTY: 13



## Table of Contents

17	Pneumatic actuated valve .....	3
17.1	Introduction .....	3
17.2	Certification.....	3
17.3	Installation.....	3
17.4	Maintenance activities.....	4
17.4.1	Disassembly .....	4
17.4.2	Assembly.....	7
17.5	Storage instructions.....	13
17.6	Lifting and handling.....	13

## 17 Pneumatic actuated valve

### 17.1 Introduction

These actuators have been specifically developed to motorize part turn valves, such as ball valves, butterfly valves or plug valves installed on pipelines for oil & gas transport and distribution.

---

#### ATTENTION

Improper use can damage the equipment or cause dangerous situations for health and safety. Rotork declines any responsibility for damage to people and/ or objects resulting from the use of the equipment for applications different from those described in the manual.

---

### 17.2 Certification

CE mark



This device is designed to meet state-of-the-art safety requirements, has been tested and left the factory in a condition in which it is safe to operate. The device complies with the applicable standards and regulations as listed in the EC declaration of conformity and thus complies with the statutory requirements of the EC Directives.

### 17.3 Installation

#### WARNING

The valve should be properly secured prior to performing the following operations according to instructions provided by the Valve Manufacturer.

Actuator to valve attachment can be performed by:

- Mounting directly using the actuator housing bottom flange drilling (NA)
- Using an adapter and a coupling joint between the actuator and the valve  
The assembly position of the actuator must be in accordance with the actuator design, plant requirements and the valve model. In order to assemble the actuator onto the valve, proceed as follows:
- Verify the coupling dimensions of the valve flange and stem; they must meet the actuator coupling dimensions
- Actuator is supplied in the fail position (for single-acting). Set the valve in the right position according to the actuator fail position. Check the position of the actuator by means of the position indicator on the body or on the limit switch box.
- Clean the coupling flange of the valve and remove anything that might prevent adherence to the actuator flange. Grease shall be completely removed
- Inspect, clean and apply grease on the coupling hole (valve side of coupling joint)
- Lubricate the valve stem with oil or grease, to facilitate assembling
- If possible, place the valve stem in a vertical position to facilitate assembly - in this case the actuator must be lifted while the coupling flange is kept in the horizontal position.
- Do not exert any force while lowering the actuator onto the valve.

- Fix the actuator to the valve by means of threaded connections (bolts, stud bolts and nuts).
- Tighten bolts or nuts of the connecting stud bolts to the correct torque, in accordance with the size and material characteristics of the bolts installed by the Customer.

## 17.4 Maintenance activities

Note:

Remove pressure before proceeding with maintenance operations, discharge any accumulators or tanks (if present), except where otherwise indicated.

	M...	Nm	
		A	B
Tightening torque table for DRY (A) and LUBRICATED (B) condition.	M5	5 ÷ 6	4 ÷ 5
	M6	10 ÷ 11	7 ÷ 8
	M8	23 ÷ 25	18 ÷ 20
	M10	48 ÷ 52	34 ÷ 36
	M12	82 ÷ 86	60 ÷ 64
	M14	132 ÷ 138	96 ÷ 102
	M16	200 ÷ 210	150 ÷ 160
	M20	390 ÷ 410	290 ÷ 310
	M24	675 ÷ 705	500 ÷ 530
	M30 (A.. 50)	620 ÷ 650	470 ÷ 500
	M30 (A.. 70)	1340 ÷ 1400	1000 ÷ 1050

### 17.4.1 Disassembly

When disassembly of actuator is required for maintenance firstly remove the actuator from the valve. Before performing any disassembly operations it is important to verify that the actuator is not pressurised. Always use caution and double check that the ports 2 and 4 are vented and are free from any accessory and/or device. When the actuator is a spring return unit, make sure that the actuator is in the failed position and with pistons completely inwards before disassembling.

A) Removal of position indicator and graduated ring, figure 1:

Remove cap screw (39) if fitted.

Lift position indicator (19 or 19.1) of shaft, it may be necessary to pry gently with a screwdriver.

Lift, if necessary, the graduated ring, (19.0) of the body, It may be necessary to pry gently with a screwdriver.

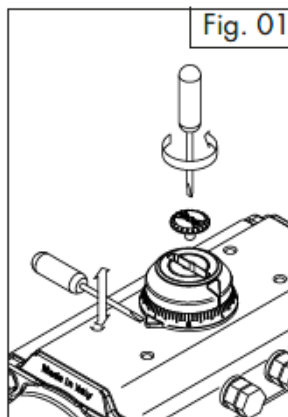

- B) Removal of stop cap screws, figure 2:  
Remove both stop cap screws together with nut (04) and washer (03).  
Remove stop screw o-rings (11) and discard if replacing all soft parts.

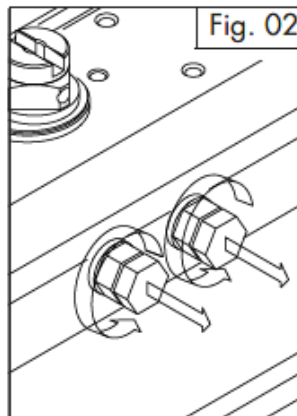

C) End caps disassembly, figure 3:

End caps disassembly for spring return actuators (disassemble one end cap at a time). Unscrew the end cap bolts (13) in the sequence shown in figure 03, until the end-caps are free from springs force.

Then completely unscrew the screws and remove the end-cap and the springs.

If there is still force on the end-caps after unscrewing as indicated above, this may indicate that spring cartridge is damaged or that the pistons are not completely closed, so any further disassembly should be discontinued. Further disassembly of the end caps may result in injury.

End caps disassembly for double acting actuators (disassemble one end cap at a time).

Unscrew the end cap bolts (13) in the sequence shown in figure 03, until the screws are completely unscrewed and the end caps are free.

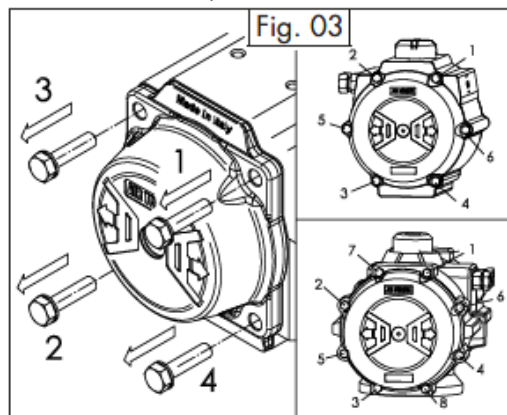

Remove the o-rings (14) using a screwdriver. Discard soft parts if replacing.

Only for actuators with adjustment 50% or 100%, remove the nut 04R, the washers 03R and o-rings 11R and discard soft parts if replacing.

D) Pistons disassembly, figure 04:

Holding the body (50) in a vice or similar device, rotate the drive shaft (60) until the pistons (40) are released. Caution: air pressure should not be used to remove the pistons from the body.

Remove o-rings (16) using a screwdriver. Remove the piston back (05) and piston head (15) bearings.

Discard bearings when replacing all soft components.

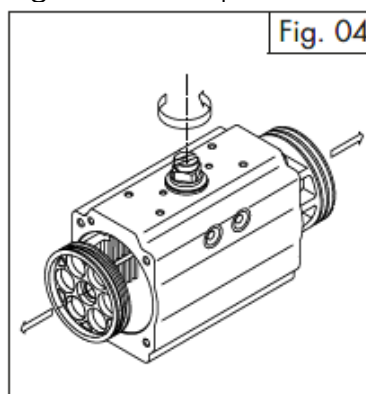

## E) Drive shaft disassembly, figure 05:

If necessary, remove the graduated ring (19.0) with a screwdriver, remove the spring clip (18) using snap-ring pliers or screwdriver for spiral rings, remove the thrust washer (10) and the external thrust bearing (08). Apply downward force to top of drive shaft (60), until it is partially out of the bottom of the body when it is possible to remove the internal thrust bearing (08) and the octi-cam (01), then push the pinion (60) completely out of the body. If pinion is not easily removed, gently tap the top of the shaft with a plastic hammer.

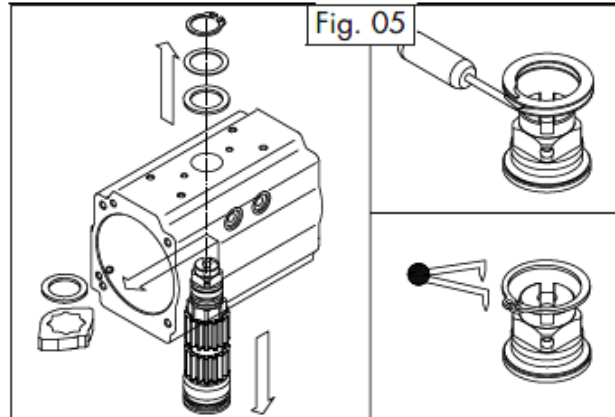

Remove the top (06) and bottom (07) pinion bearings and top (20) and bottom (21) pinion o-rings.

Discard bearings (06) and (07), internal and external thrust washer (08) and o-rings (20) and (21) if replacing the soft components.

All components disassembled and not replaced will have to be cleaned and inspected for wear and before reassembly, if necessary, also replace the plugs (09).

## 17.4.2 Assembly

Prior to assembly, ensure that:

- All the components are perfectly clean and in good condition.
- The spare parts and the lubricant used are suitable for the operating temperature of the actuator (see technical data sheet).
- Note: the lubricants suitable for the various operating temperatures (standard, HT and LLT actuators) are available.

A) Drive shaft assembly, figures 06, 07 and 07A:

Install top (06) and bottom (07) bearings, grease and insert the bottom (20) and top (21) pinion o-rings onto the shaft.

Grease the outside surface of the drive shaft as shown in figure 06.

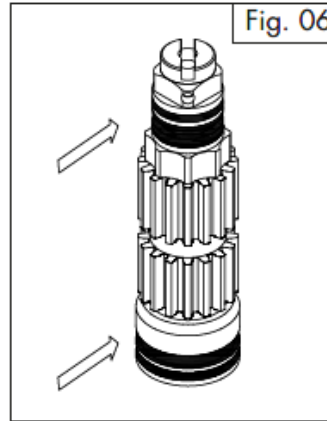

Insert partially the drive shaft (60) in the body (50), install octi-cam (01) in the correct position (for standard assembly or for lock-out) as shown in figures 07 and 07A, related to the bottom and top of the actuator when energized. Install the internal thrust bearing (08). Insert completely the drive shaft in the body.

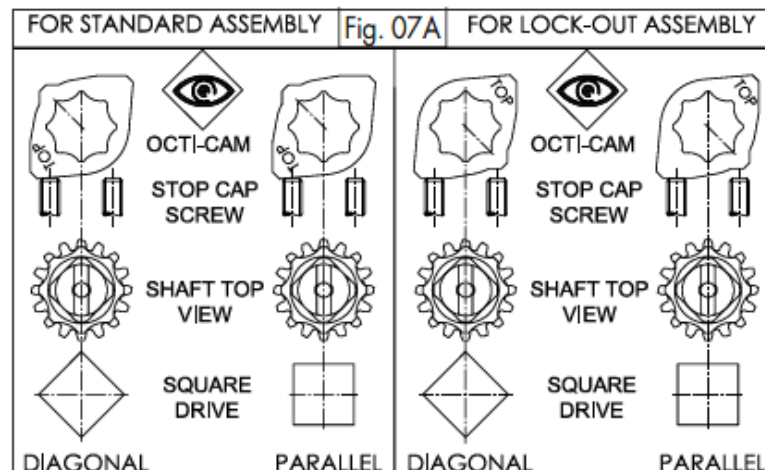
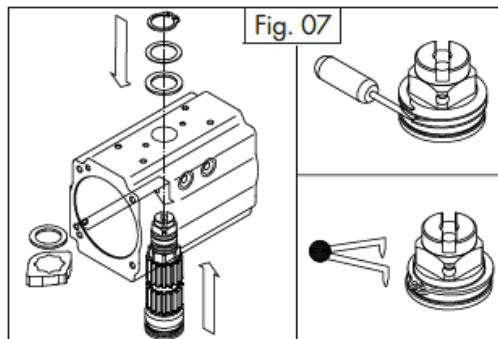

Fit external thrust bearing (08), thrust washer (10) and then external spring clip (18) using snap ring pliers or screwdriver for spiral rings.

- B) Pistons assembly, figures 08, 09, 10 and 11:  
Grease and install o-rings (16), pistons back (05) and pistons head (15) bearings.  
Grease the internal surface of the body (50) and the piston (40) rack teeth..  
Insert the female connection of the drive shaft (60) in a properly fixed coupling.  
Ensure that the octi-cam is in the right position as shown in figure 09.

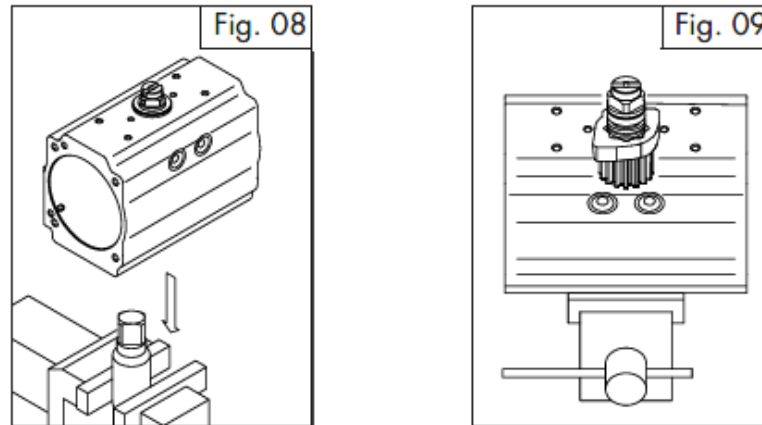

For standard rotation assembly type "ST" (clockwise to close), rotate the body (50) about 40-50 degree clockwise from top view, as shown in figure 10.

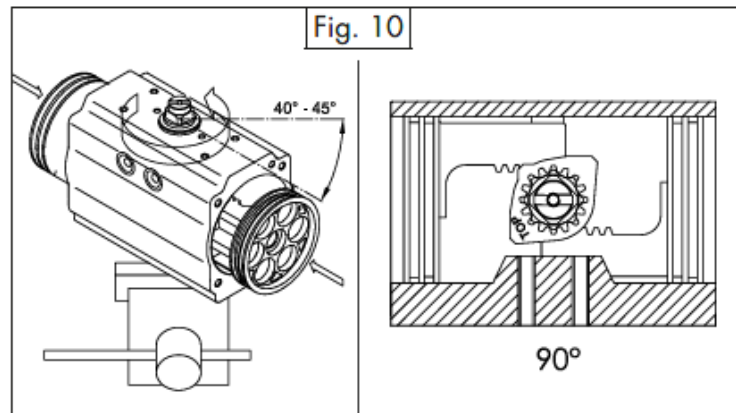

Insert and press the two pistons (40) simultaneously inside the body (50) until the pistons are engaged, then rotate the body anticlockwise from top view until the stroke is completed.

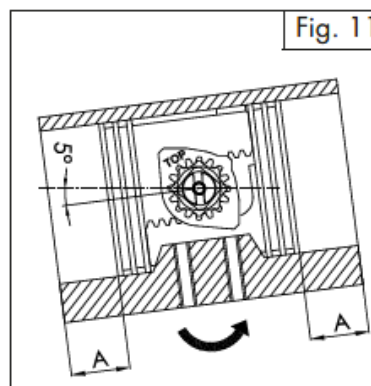

## C) End cap, figures 12, 13 and 14:

Assemble one end cap at the time.

Lubricate the body.

For spring return actuators, insert the springs in each end cap according to the desired configuration, as shown in figure 12 and related tables.

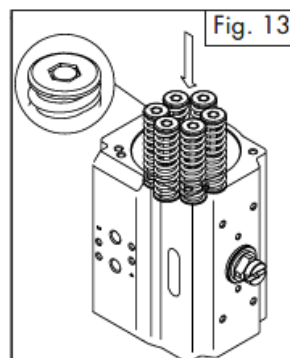
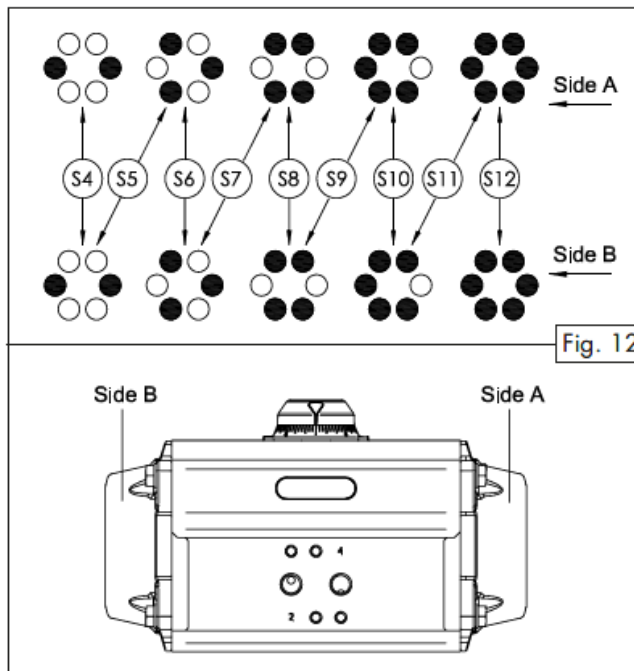

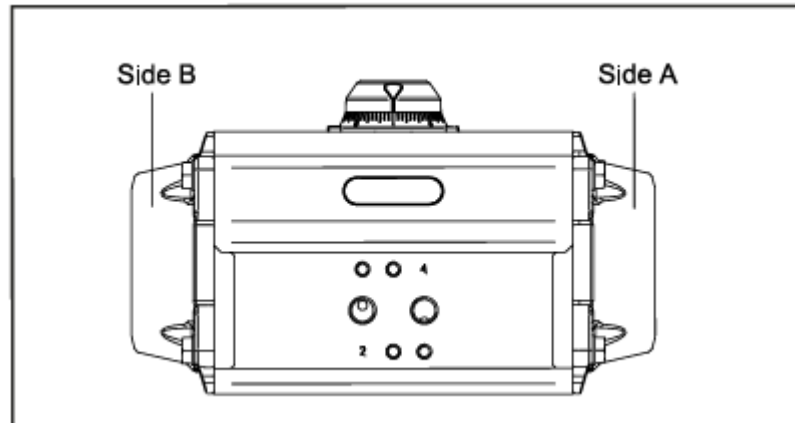

Fit end cap o-ring seal (14) into the groove on both end caps.

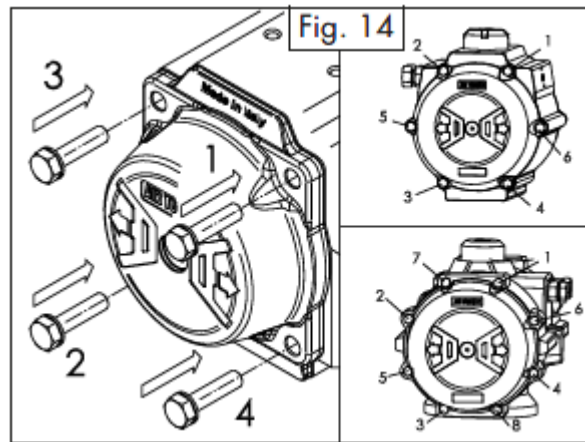

Fit end caps onto the body (50), verifying that the o-ring remains in the groove.

Only for actuators with 50% or 100% stroke adjustment, ensure that the adjustment screws 221G/222G are completely screwed into the end cap.

Insert the cap screws (13) and tighten each only partially. Complete tightening by making 1-2 turns for each screw in the sequence shown in figure 14 until tightening is completed. See the table for screw tightening torque.

D) Assembly of stop cap screws and stroke figures 15 and 16:

Insert on both stop screws (02) the nut (04), the washer (03) and the o-ring (11).

Fit the stop cap screws (02) in the body.

Stroke adjustment for actuators with standard type "ST" rotation / assembly (clockwise to close).

Stroke adjustment in close position: with the actuator in close position 0, screw or unscrew the right (from top view) stop cap screw until the desired stop position is achieved. Then tighten the stop adjustment nut (04) to lock it in place.

For spring return actuators, it could be necessary to make rotation tests to verify the correct stroke adjustment in open position.

Only for actuators with adjustment 50% or 100%, fit on end-cap adjustment screws 221G/222G the o-rings 11R, the washers 03R and the nuts 04R. to adjust the stroke I

open position: with the actuator in partially or totally open position, screw or unscrew

the end-cap adjustment screw 221G/222G until the desired position is achieved. It is important that the two end-cap adjustment screws are both in contact with the pistons. Then lock the nuts 04R.

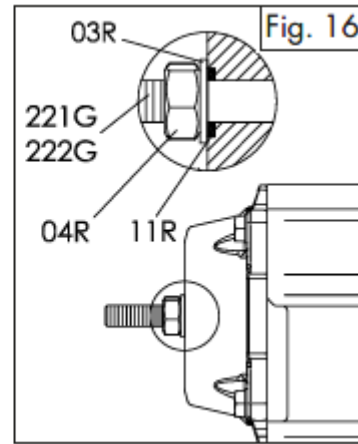
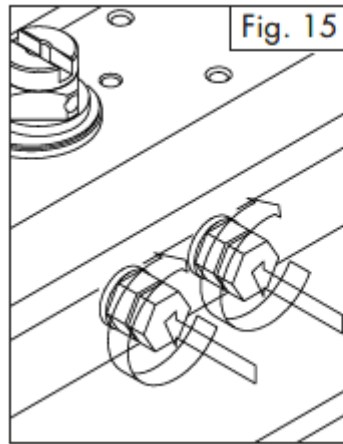

- E) Assembly of graduated ring and position indicator, figures 17, 18 and 19:  
 Fix the graduated ring (19.0) to the body.  
 If necessary, correctly position the "top adaptor" (19.5) and lock it with the proper screws (19.6).  
 Insert the indicator (19 or 19.1) making sure that it indicates the correct actuator position.  
 Screw the indicator screw (39) if assembled.

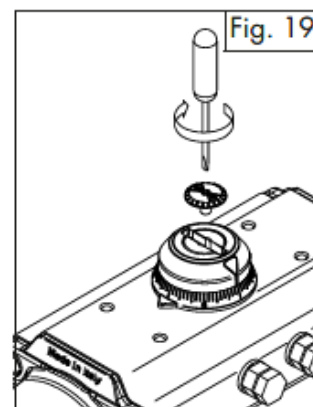
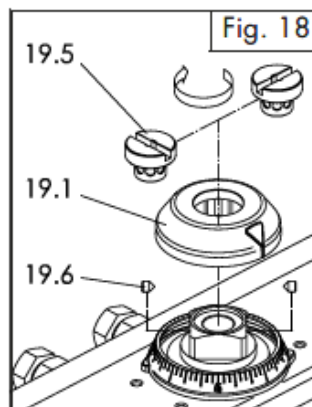
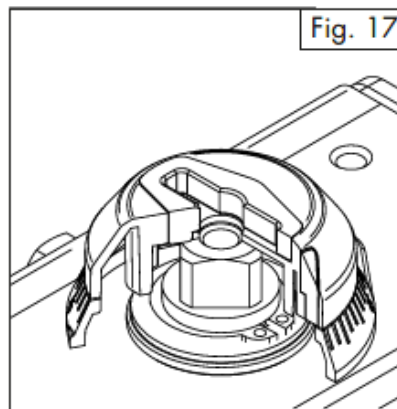

## 17.5 Storage instructions

If the actuator is not for immediate use, the following precaution must be taken for storage: Store the actuator in a clean and dry environment and at temperature between -20C (-4F) and +40C (+104F).

It is recommended that the actuator be stored in its original box.

Do not remove the plastic plugs on air supply ports.

## 17.6 Lifting and handling

It is recommended to lift the actuators with proper, adequate and permitted systems in relation to the actuator weight and by following the ruling laws in terms of safety and health protection. The weight of the actuators is indicated on the data sheets.

During the lifting and the handling of the actuators, it is recommended to avoid clashes and/or accidental falls in order to avoid irreparable damages to the actuators and to compromise the functionality.

# Bushehr MEG Plant Project

<b>VENDOR NAME</b>	: Airpack Nederland B.V
<b>EQUIPMENT DESCRIPTION</b>	: Nitrogen & Instrument Booster Package
<b>EQUIPMENT TAGNUMBER</b>	: 20-C-1002, 20-C-7080

## SECTION 18

## GLOBE VALVE



Vendor doc. Number

17811-20

Vendor:

Airpack Nederland B.V.

P.O. NO.:

MEG20-PO-BP303-021

SHEET QTY: 21

## Table of contents

18	Globe valve .....	3
18.1.	Introduction.....	3
18.2.	General description.....	3
18.3.	Valve storage.....	3
18.4.	Valve installation.....	4
18.5.	Valve operation.....	8
18.6.	Maintenance .....	8
18.7.	Precautions .....	14
18.8.	Residual risk list .....	15
18.9.	Explosive atmospheres (ATEX / UKSI) .....	16
18.10.	Environmental precautions .....	17
18.11.	ANNEX A – NPT assembly instructions .....	18
18.12.	ANNEX B – Body bonnet bolt or screw tightening specification.....	19
18.13.	ANNEX C- Troubleshooting guide.....	21

## 18 Globe valve

### 18.1. Introduction

This manual has been prepared to provide the end user with general guidelines in the installation, operation and routine maintenance of BFE valves. If, after reviewing the contents of this manual, you require any special instructions, assistance, repair services or have any additional questions, please contact either our factory or our nearest representative for assistance.

### 18.2. General description

Technical data:

Nameplate & Valve Information.

The nameplate permanently attached to the valve, provides you with the rated working pressure, temperature range and material used. When ordering replacement parts, reference to the information provided on the nameplate will aid in ensuring that you receive correct component parts for your valves.

**WARNING!!!** Never attempt to modify BFE valves in any way without authorization and assistance of Airpack BV, otherwise the mechanical guarantee will not apply and severe damage to the equipment could result.

### 18.3. Valve storage

Preparation and Preservation for Shipment

Preservation and other protective measures for shipment must be sufficient to protect against deterioration and physical damage during shipment. The type of packing must be defined in the Customer's Order and shall be appropriate to ensure safe transportation and conservation before installation. The valves are normally shipped from the factory in boxes, crates or on skids. Protruding parts, such as the handwheels, indicator rods, and stem protectors are sometimes removed from the valves and either attached to the box or crate or packaged separately.

Inspection Procedure

All valves and associated parts should be inspected carefully for any visible sign of damage and if necessary, claims promptly submitted to the carrier. Any parts shipped loose or separately should be properly packed to prevent lost or damage. Care should be taken in handling valves to prevent damage, particularly to equipment extending above the valve bonnet and any fittings protruding from the valve body. Upon receipt, the valves should be inspected for shipping damage. If the end protectors are removed for inspection purpose, be sure to re-install them to maintain internal cleanliness. If caps are missing, an inspection of the valve cavity is required. All foreign matter must be removed.

### Handling

- Most handling can be accomplished by placing “hook” diagonally into holes on each side of the end flanges, or by the usage of straps slung around the arms of the valve body.
- Never lift or move the valve assembly using the bore, shafts, nuts as a pressure point.
- Never lift or move the valve assembly by using the actuator, positioner, extensions, handwheel, gland bolting or other valve options.
- Transport, unpack and store being careful not to scratch the surfaces of flanges or gaskets. Also take steps that will prevent any foreign matter from getting into the valves. Wooden plate or plastic caps should not be removed until the valve is installed.
- The transportation of all packed material must be carried out safely and following the local safety regulations.

### Storage procedure

- If the valves are to be stored for any extended period of time, the flange or end protector should be examined to ensure they are fastened securely, and any other open areas should be sealed to prevent any moisture damage.
- All valves should be securely held in place by banding or other means of support to prevent accidental damage due to movement of the valves.
- Valves should be kept in a clean, heated, weather tight (dry), well-ventilated, fire-resistant storage facility with flooring that seals against dust and dirt and will not be subject to flooding.
- Valves should be stored off of the floor on suitable skids, pallets or racks and protected from dirt, debris and exposure to direct sunlight, particularly to soft sealing surfaces.
- Valve assemblies with electrical components, pneumatic tubing, positioners, actuators, and other accessories should be protected from impact.
- The end faces must be protected from rust and dust with plastic or wooden discs fixed with straps.
- Periodical checks at least every 6 months have to be carried out in the storage area to verify that the above-mentioned conditions are maintained.

## 18.4. Valve installation

### General

- Remove valve assembly from box or crate with caution.
- Prior to installation, confirm that there are no scratches on the surfaces of flanges and stem. Also, make sure that the inside of the valve port area and seat surfaces are cleaned with a dry cloth. The seat surfaces are most important in achieving optimal valve performance and special attention should be taken to ensure that there are no “scratches” or defects to these surfaces.
- All BFE Valves are shipped from the factory in the closed position and normally will have a coating of rust protective oil. Before installing the valves, all oil or grease (used to protect the valve) should be removed taking care not to damage the seat contact surfaces.
- Following installation of the valve, operate the gate disc fully open and closed at least once prior to hydrostatic testing of the line to ensure freedom of operation.

- Ensure that the construction materials listed on the valve nameplates are appropriate for the service intended and are as specified.
- For threaded ends use conventional sealant, for flanged ends or other ends (clamp etc) use the standard method described in the international standards.
- After the valve installation and before the line testing, it is recommended to perform an accurate cleaning of the lines to eliminate dirt and any foreign matter that could seriously jeopardize the tightness between seat/disc and the correct operation of the valve.
- If the valve has been stored for a long time, check the bolt torque for all bolting.
- Packing compression should be carefully inspected and if necessary, packing gland bolts torque should be adjusted.
- If piping system is pressurized with water for testing, and in case the piping system has been shut down after testing for a long time, it is recommended to use corrosion inhibitor with water to pressurize the piping system and after testing, the piping system should be depressurized and the test water completely drained.
- The pipeline must have a pulsation dampener if there are pulsation sources in the line. Lines subjected to pipe vibration and pulsation affect the lifetime of the valve seal parts.
- After completion of hydrostatic testing, the valve should be drained to eliminate any water or test fluid which may have been trapped in the valve.

Installation table based on valve connection type

Simply choose your procedure depending on the Valve End Finish:

#### Flanged end

Make sure that two like flanges are being fitted together. Usually, the proper set-up is either plain face to plain face or raised face to raised face flange. Tighten the flange bolts in a crossover pattern as follows:

- A. Slightly torque all bolts using a crossover bolt sequence. Bolts should be tightened evenly to prevent cocking of the flange and uneven gasket loading.
- B. Repeat step 'A' using additional torque until all bolts are tightened properly. This may require several re-torques because as one bolt is torqued, it will relieve stress on the adjacent bolts.
- C. On high pressure, high temperature applications, it is recommended that the bolts be retightened after 24 hours of operation to compensate for any relaxation or creep that may have occurred.

#### Butt welding end

**WARNING!!!** Gate and Globe valves should be lightly open to prevent damage to the seating surfaces and stem caused by thermal expansion during the butt welding process.

#### NOTES:

- Proper welding is required to ensure a pressure tight seat and to retain its ability to withstand stress. Remember that the valve, pipe and weld root must be of compatible materials and the welding be performed by a properly trained welder and approved weld procedures and qualifications.
- Be sure to leave a proper gap between the end of the pipe and the end of the valve. This will allow for expansion of the materials as it is welded, any extended

welding time could cause excessive heat build up on the valve seat area which could cause damage such as loosening of the seat rings, surface distortion etc.

- The specified PWHT can then be performed in line without affecting the valve. Shortly after welding, open and close the valve to check for proper operation to make sure no binding has occurred due to welding heat.
- Also welding slags and spatters are to be completely removed and cleaned to avoid damage on seating areas.
- Where possible, attach the electrical ground to the adjoining pipe on the same side of the valve as the weld being made. Do not attach the earth to the handwheel or upper structure of the valve or arcing across the valve seating surfaces could occur.
- Where possible, welding should be done in the flat or horizontal position. Where vertical welding is necessary, progression should be upward (vertical down welding is prone to lack-of-fusion).
- During the PWHT only the valve body must be insulated in order to not overheat the packing-stem region.

#### Socketed weld end

**WARNING!!!** Gate and Globe valves should be lightly open to prevent damage to the seating surfaces and stem caused by thermal expansion during the socket welding process.

Weld the connection as follows:

- A. Remove all grease, oil or paint from the pipe that is to be welded into the valve and from the valve end connections.
- B. Insert the pipe into the valve end connection until it bottoms out in the socket weld bore.
- C. Withdraw the pipe 1/16" so that a gap remains between the pipe and the bottom of the socket weld bore to prevent cracks (ASME B16.11). Tack the pipe into the valve and complete the fillet weld.

#### NOTES:

A minimum of two layers should be used for all socket welds. This will decrease the chance of leaking even if one pass contains a weld defect.

- The specified PWHT can then be performed in line without affecting the valve. Shortly after welding, open and close the valve to check for proper operation to make sure no binding has occurred due to welding heat.
- Where possible, welding should be done in the flat or horizontal position. Where vertical welding is necessary, progression should be upward (vertical down welding is prone to lack-of-fusion).
- During the PWHT only the valve body must be insulated in order to not overheat the packing-stem region.

#### Clamp end

Clamp installation and maintenance instruction (clamp, clamp gasket and clamp bolting's and nut) and are not scope of the valve manual. See the clamp manufacturer IOM for details.

#### Threaded end

See annex A of this manual.

### Valve positioning

Positioning the valve in the pipe run is very important. Prior to actual installation, check for clearance around the valve to ensure adequate space for proper operation. Also, keep in mind the need for clearance for future maintenance and repair. Once proper positioning and clearance have been assured the system should be cleaned of all foreign matter. Whenever possible, blow out the pipeline with water to remove grit and dirt. Also be sure to remove the valve end protectors and check the valve again for cleanliness.

**ACTUATED VALVES:** valves are designed to withstand the actuator only with stem in vertical position. If the installation requires a different stem position, user must fasten the actuator to avoid damage or incorrect working of valve-actuator system.

### Valve positioning for Gate & Globe valves

Gate and globe valves should be installed with the stem in an upward position on horizontal lines. However, an alternative stem position is at an angle between the vertical and horizontal axis that will allow for complete drainage. If installed with the stem below the horizontal axis, complete drainage is not possible and solids may accumulate in the valve bonnet that will greatly affect the valve operation and service life. A gate valve can be installed in line with disregard to flow direction. However,

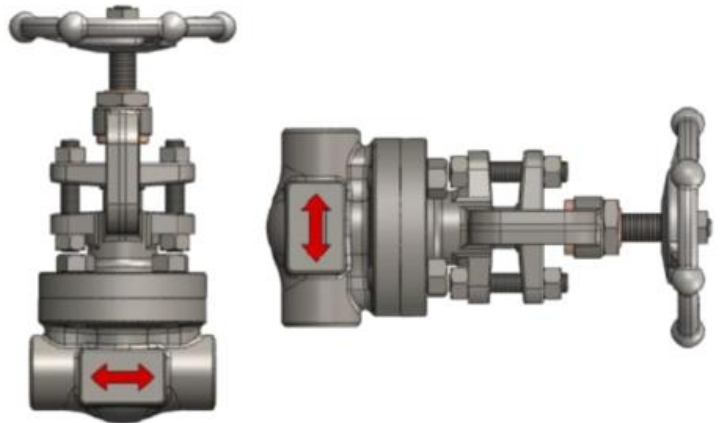

install the valve carefully according to the flow direction arrow when the disc is provided with pressure balance holes to prevent abnormal pressure increase.

### Valve positioning for check valves

Check valves must be fitted in horizontal pipe runs with the cover facing vertically upward. Variance to either side of the vertical axis must not exceed 5 degrees. Swing check valves and spring-loaded check valve design allow for additional position, such as vertical upwards flow. Valves must not be installed in vertical downward flow pipe runs or in horizontal pipe runs with the cover not in vertical up position. Always install valves in the direction indicated by the flow arrow stamped on the body. Piston and stop check valves should be fitted similarly to check valves.

**NOTE.** Spring loaded check valves can be installed with fluid direction from downward, but it's not advisable, the gravity effect cannot ensure a proper sealing in the event of a back-flow from downward.

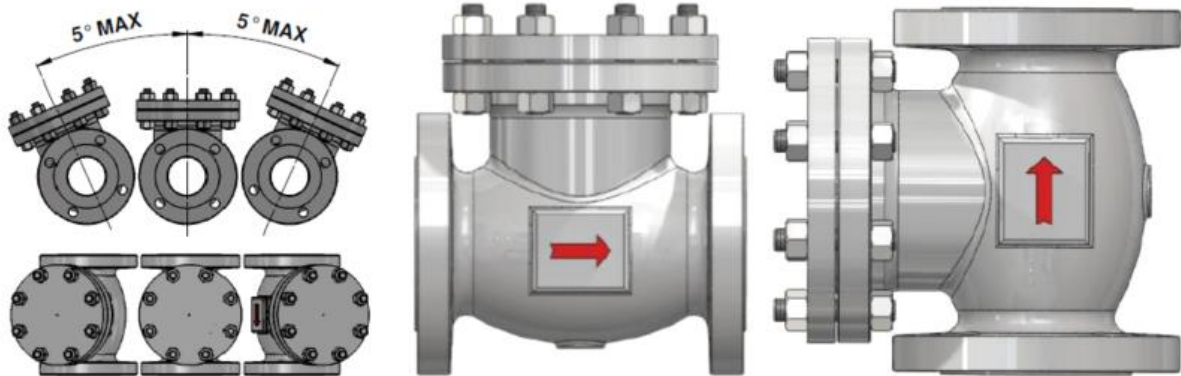

### Purging and testing of line

Once the valve is in line, open the valve and flush or blow out the line again to remove any dirt or foreign objects that may have collected during installation. Check for tightness of body/bonnet bolts and for proper packing gland adjustment. Operate the valve to ensure correct operation. Pressure test the valve to ensure the integrity of all joints.

## 18.5. Valve operation

- The gate/globe valve is closed by rotating the handwheel in a clockwise direction; and is opened by rotating the handwheel in a counter clockwise direction.
- Do not apply excessive torque to the gate of the valve after it has reached the fully open or fully closed position as this could result in damage to the gate, stem or operating nut.
- Gate valve should be used in fully opened or fully closed position. If it is used in a slight or half opened position, the disc may vibrate at a high speed that may cause pulsation of the flow. Therefore, do not use a gate valve for flow control or throttling service.
- Globe valves can also operate in either direction of flow, but it is recommended that pressure is always against/under the disc.
- **WARNING:!** If the valve is SLAB or PARALLEL SLIDE TYPE: When the position is in the closed position the valve is fully isolated. **DO NOT APPLY ANY ADDITIONAL FORCE.**

## 18.6. Maintenance

### General

**WARNING!!!** Do not remove or disassemble the valve while it is under pressure. Depressurize the line and the valve as following:

- ✓ Place the valve in the open position and drain the line.
- ✓ Cycle the valve to relieve the pressure trapped in the body cavity.
- ✓ After removal and before disassembly, cycle the valve several times.

	BUSHEHR MEG PLANT PROJECT	Rev.: 00
	Globe valve	Date: 08-11-2024

WARNING!!! Line Fluid can be toxic, corrosive or dangerous the health and safety. Protect yourself and others by observing all applicable standard procedures. Make the right choice, SAFETY FIRST!

Recommended preventive maintenance

Maintenance programs vary greatly from application to application, depending on factors such as operational frequency, fluid make-up, external environment, etc. The end user should establish a routine maintenance program to extend the life of the valves and minimize downtime for repair.

SUGGESTED MONTHLY MAINTENANCE	SUGGESTED 6 MONTHS MAINTENANCE
1. Visually inspect the valve for signs of leakage or corrosion. 2. Visually inspect the stem packing to avoid any leakage from the stuffing box. 3. Lubricate the valve, if necessary ( stem and stem nut ).	1. Cycle the valve fully open and closed at least once to check for freedom of operation. 2. Remove the stem protection (if any) and lubricate the valve stem. 3. Repeat steps 1, 2 and 3 from the monthly maintenance recommendations.

Maintenance instruction

The maintenance and repair of BFE valves is usually limited to the adjustment of the packing gland and the lubrication of yoke sleeve as previously stated. For standard maintenance of valves, the only components suitable to be substitute are: Stuffing box packing & Body/bonnet gasket. For special ordinary maintenance the seat replacement and the seal surface retrofit can be performed. Should you need to perform the mentioned above repairs the following information should be used as a guide in your repairs always in conjunction with the applicable GAD (ask BFE if you don't have it). For special requirements ask BFE for special custom instruction & VGI.

STEM packing

If the gland has run out of travel or excessive tightening does not stop the leakage, isolate and de-pressurise the valve for repacking. The valve need not be taken out of line for simple repacking, however, repacking is not recommended while the valve is in service.

If the stem does not backseat correctly and seal completely against the backseat bushing, the stem packing cannot be replaced while the valve is under service conditions. To extract packing remove the gland nuts and studs, lift the gland flange and gland out of the stuffing box. Next, remove old packing, by using an extractor tool of the correct size. Any remnants of old packing must be removed from the stuffing box and the stem. Clean the stem and stuffing box and examine it for damage. Install new packing rings, one at a time.



Each ring should be firmly compressed into position before the next ring is added. Rings should fit snugly into the stuffing box. Install the gland and the gland flange and secure with the gland nuts. Tighten the nuts uniformly, but only to the extent needed to prevent leakage. When graphite packing is to be installed, their replacement may be made by cutting the preformed rings in two halves/by a single cut and carefully opening the ring to allow its insertion into the stuffing box. Procedure to insert is then the same as stated for normal packing.

SUGGESTED GLAND BOLTS TORQUE [ Nm ]						
VALVE NPS	ASME CLASS					
	UP TO ASME 800		FROM 900 UP TO 2680		ABOVE 2680	
	FULL	REDUCED	FULL	REDUCED	FULL	REDUCED
3/8"	5	N.A.	12	N.A.	24	N.A.
1/2"	7	5	14	12	30	24
3/4"	8	7	18	14	35	30
1"	10	8	20	18	40	35
1"-1/4	12	10	22	20	46	40
1"-1/2	14	12	24	22	50	46
2"	16	14	26	24	65	50

Gasket replacement (bolted bonnet valves only)

Complete disassembly procedures are listed below. However, it is recommended that disassembly be limited only to the extent required to carry out repairs.

1. Isolate and de-pressurize the system and operate the valve to its full open position.
2. Match mark the body and bonnet, the wedge and body to maintain their relation upon reassembly.
3. Remove the body bolts and lift up the entire bonnet assembly, taking care not to damage the wedge.
4. Examine the gasket-seating surface of the body and the bonnet for evidence of wear damage or deterioration.

5. Discard the old gasket. Replace or repair all damaged parts, then clean the seating surfaces to remove all rust, gasket residue and other debris.
6. Polish the gasket-seating surfaces using a fine emery cloth. Remove any radial scratches or other defects, taking care that the emery cloth does not remain in the valve.
7. A radial scratch across the seating surface may allow for a leak path. To affect a good seat, the gasket-seating surface must be flat and should have a finish between  $Ra=1.6$  and  $Ra=3.2$ .
8. Again, clean the surface to remove all polishing residue. Install a new gasket and reassemble the valve. No gasket-sealing compound should be used when installing the gasket. Care should be taken to ensure that the wedge does not contact the seats during reassembly and bolt tightening. Re-tighten the bolts acc.to Annex "B" of this manual.

### Valve seating

#### General for gate and swing check valves

The valve and seat ring design and the method of seat ring installation are such that the valve must be removed from the line when seat ring replacement is necessary. Therefore, we recommend that the valve be replaced or returned to the maintenance workshop for seat replacement. Seat rings for gate valves, sizes 1" and larger, if not too badly damaged (defect not deeper than 0.8 mm), may be repaired in the body by lapping. Smaller size valves can be repaired, but with great difficulty; therefore we recommends the installation of new seats. The seats can be lapped in the body, using a flat lapping plate larger than that of the seat. The plate must have a square hole in the center for attachment to a square end tool. Make a square tool of suitable size and length with one end to fit a brace and the other end attached to the plate. Valve seats can then be hand lapped by using a fine grain compound. Wedges can be lapped on any surface plate, but care should be taken to maintain the correct wedge angle. As noted previously, we recommend that the valves be replaced or returned to the factory for seat ring replacement. However, it's suggested the following instructions are issued to aid in any attempts of seat replacement in the field maintenance workshop.

#### Seat removal & replacement for gate and swing check valves

The valve and seat ring design and method of seat ring installation are such that the valve must be removed from the line when seat ring replacement is necessary. Therefore, BFE recommends that the valve be replaced or returned to the factory for seating ring replacement.

#### General for globe and piston check valves

Prior to lapping the disc of the globe valves, the disc may require machine refinishing. When defects are found on the stem/disc assembly-seating surface, it is recommended to place the stem/disc assembly into a lathe spindle and check the disc diameter, without taking the assembly apart. Hold the disc using a 3-jaw chuck so that large OD and seating surface run true. Grind the seating surface using a tool grinder. Machine only deep enough to clean the surface, then polish the seating surface with a fine emery cloth, retaining the original shape of the disc. When surface damage is minor, the seats may be repaired by

a lapping operation use a small quantity of lapping compound between the seat and the disc surfaces.

It is important that not too much pressure be applied to the disc and seat. With the lapping compound in place, between the mating surface, the disc should be reciprocally rotated, the strokes should be light, and the disc should be lifted frequently and turned to a new position (circularly around the valve body) so the lapping will take place over a new area. Continue lapping until all defects are removed, and then apply a final finish with a fine compound. It is recommended that the face of the disc be "blued" to check for contact of seating surface after final lapping. The globe valve stem/disc assembly may be used in the lapping operation, however, due to its loose disc design, it is necessary to prevent the disc from rotating on the stem.

This can be accomplished by preparing a fixture (the valve handwheel can then be re-attached to the stem and used as a convenient handle when re-lapping the seats).

Valves having renewable (threaded-in) seats may have the seat ring replaced only in the factory by means of special tools. The seat ring may then be removed by un-threading in a counterclockwise direction. The seat threads in the valve body should be carefully inspected to make sure they are in a usable condition. When installing new seats, the seats should be screwed tightly into the valve body, then unscrewed to make sure they are making continuous contact for a tight seal.

Suggested tools & consumables for lapping

- Lapping compound (Carborundum).
- Grain size: 400 – 600 mesk – for rough finishing.
- Grain size: 800 – 1200 mesk – for fine finishing.
- The surface plate should be homogenous cast iron having approximately HB 250 hardness. Machine oil, fillet scraper, bluing compound and waste cloth.



Lubrication

The valves are made from selected materials to give long and trouble free service, when properly installed for the correct applications. Proper care and maintenance in the field can contribute to extended performance of the valve. The general maintenance operation on a valve usually consists of periodical lubrication. See the lubrication chart below for details:

Lubrication chart		
STEM threads lubrication	Gear housing lubricant	Sleeve lubricant
<p>Exposed stem threads should be kept clean and should be lubricated. Because a tacky lubricant on exposed stem threads can attract abrasive particles from the atmosphere the use of dry lubricants is recommended. Graphite powder can be applied by spraying or by the use of a normal brush. When valves will be supplied according to Statoil specifications, We will use Molykote BR2 plus grease approved by STATOIL.</p>	<p>On valves equipped with bevel gear operators, the operators are basically sealed units which are considered to be permanently lubricated. Airpack recommends that the operators be at least partially disassembled every three years to inspect the condition of the lubrication and component parts. Should dirt, water or other foreign matter be found during the inspection, the units should be flushed using a commercial cleaner/degreaser which is not corrosive or incompatible with bearings and gears. Other close fitting parts should be liberally coated by hand with grease prior to reassembly.</p>	<p>The valve yoke-sleeve shall be lubricated periodically based on cycle and service conditions, but not less than once a year or 100 cycles maximum. Any good grade of grease may be used on these parts. Only a small amount of grease is required over lubricating the stem bearings will result in the leakage of grease around the bearing housing.</p>
<p>MANCON MACONSYNTH HT (Airpack SUGGESTION) or MOLYKOTE BR2 PLUS or TOTAL MULTIS MS2</p>	<p>AGIP GR MU EP 2 (Airpack SUGGESTION) or STATOIL UNIWAY LI-62 or ESSO BEACON EP1</p>	<p>MANCON MACONSYNTH HT (Airpack SUGGESTION) or MOLYKOTE BR2 PLUS or TOTAL MULTIS MS2</p>

IMPORTANT NOTE!!! For oxygen service use only packing and lubricant BAM or WHA approved. Lubricate only if necessary.

List of ordinary maintenance tools

1. Seat removing tools (for removal of the threading seat rings, these tools can be supplied on request).
2. Packing extraction tool (can be supplied upon request).
3. Injector gun (can be supplied upon request).

## 18.7. Precautions

Working pressure and temperature	When using the valve, be sure to work with proper pressure temperature combinations within the maximum allowed as per the ratings marked on valve nameplate. The rating tables are those of ASME B16.34 or EN 12516-1 as applicable. For special materials and conditions not "Rated", check that the design condition specified in the customer order, are correctly specified and applied (also check the valve nameplate).
Valve material choice	It is the client's responsibility to select the correct material, based upon the media and operational condition. The correct choice will aid in increasing valve life expectancy and vice versa, corrosion, erosion or other factors which can lead to a reduced valve life.
Corrosion allowance	Standard valves are designed to be safe taking into account a maximum corrosion allowance of 3mm. Never use the valve with a higher corrosion allowance unless specified in the customer order.
Pipeline load	Standard valves have not been designed for support purposes, hence the client must avoid any significant pipeline load concentrations at valve interface. If requested, BFE can supply the necessary information to allow the customer to perform the relevant verification or be required to perform the verification based on client data.
Cyclic load	In case of a significant number of cycles and load variations, further stress analysis shall be performed to verify the valve strength. This being the case, BFE can supply the necessary information to allow the customer to perform the relevant verification, or can be asked to perform the verification based on client data.
Start-up	Once the valve has been installed in accordance with all the procedures and precautions as described in the previous chapters, the valve can be started-up. For gate valves only, be careful not to heat-up the valve in a closed position with fluids inside, this could result in over pressurizing the valve.
Normal operation	When in operation, the gate and globe valve can be hand-operated from open to close or vice versa by

	the handwheel. Prior to operating the valve, make sure that the temperature of the handwheel is not too hot or cold which could result in injury to the operator's hands.
Shut-down	No special procedures are required for shut-down.
Fluid group P.E.D. / P.E.R.	According to P.E.D. 2014/68/UE & P.E.R. - PRESSURE EQUIPMENT (SAFETY) REGULATIONS, SI 2016 No. 1105 the valves / strainers are classified in category III (highest possible category) and then can be used with fluid group 1 or 2 including unstable gas.
Valve modification	In no case is the user allowed to modify the geometry or the material of valve components. This action determines the immediate expiring of factory warranty.

## 18.8. Residual risk list

Important note! All Valves and actuator assembly

Residual risk	Note
Noise	Valve and operator equipment (e.g., actuator) are designed in order to not generate any noise above 70dB(A). However, the user must evaluate the process data to consider if the noise generated by the flow can produce with the applicable environmental legislation governing noise nuisance. If required protective equipment such as earplugs or other noise reduction equipment must be used.
Equipment maintenance	Any action related to the installation and maintenance of equipment not part of the valve product (e.g. Actuator or Limit-Switch ) must be performed according to the IOM issued by the equipment manufacturer.
Equipment operation	Any action related to the operation of equipment not part of the valve product (e.g. Actuator or Limit-Switch) must be performed according to the IOM issued by the equipment manufacturer.
Electrical and ATEX / UKSI	System grounding is the responsibility of the user or system designer during the first installation and at every maintenance operation the grounding must be verified. During maintenance operation must be verified that all electrical and pneumatic energy sources are proper disconnected. All electrical connection where applicable must be performed acc.to local regulations ( e.g. EN60079-14 )

## 18.9. Explosive atmospheres (ATEX / UKSI)

Valves may be used in potentially explosive atmospheres. Where the customer require valves in conformity to ATEX 2014/34/UE or UKSI 2016:1107 B.F.E. can supply valves in conformity to Zone II category 2. In accordance with the above Directives. in this manual B.F.E gives some indications to the valve users on how to operate in safe conditions.

Leakage from packing	Check frequently the condition of packing and monitor the amount of emission by the use of suitable means (i.e. sniffers); in the case of significant leakage level change or adjust the packing.
Leakage from body/bonnet connection	In the case of valve leakage through body-bonnet joint, it is necessary to substitute the gasket.
Inadequate lubrication	In the case of long and frequent operations, the friction between stem, yoke sleeve and bonnet, can cause a local increase of the temperature. Therefore we recommends lubricating all the parts involved.
Inadequate electric continuity	The valves are made with permanently contactable steel components hence a full electric continuity is guaranteed. If the connection to the pipeline does not guaranty the metal continuity (i.e. flanged connection with fully or partially non metallic gasket) we suggests adopting equipotential devices.
Inadequate thermal insulation	Valves can be used at any temperature allowed by the relevant rating table; the high temperature of external surfaces can be a potential cause of explosion. In this case it is good practice to insulate the valves when used in hot conditions with similar devices as adopted for the rest of the pipeline. However, the temperature of the fluid conveyed in the inner part has to be compared with the minimum temperature for priming of explosive atmosphere in order to check the compatibility.
Electric components	If the valves need any electrical equipment mounted, check if the Ex certificates of the electric components are for the protection level necessary for the site conditions.
Presence of powders that may trigger explosion	The valves are constructed in such a way that any powders in the surrounding environment cannot enter the valve itself. Nevertheless, it is recommended to check at regular intervals the fastening of the stuffing box in order to prevent the infiltration of these powders, which, after contact with the inner fluid/gas, might trigger explosions. During the cleaning of the external valve surfaces, it is recommended to use wet cloths to prevent electrostatic effects, which may trigger explosions, if in contact with the powders themselves.

## 18.10. Environmental precautions

The following are the indications of good practice which should be adopted during the life cycle of the product for correct use and in order to protect the environment and prevent pollution.

Assembly	<p>When installing the valve, the materials for packing and protection have to be removed and disposed of according to the following procedures:  <b>DO NOT BURN IN UNCONTROLLED WAY DISPOSE ACCORDING TO THE NATIONAL RULES IN FORCE PREFERABLY RECYCLE – ALL THE PACKING MATERIALS USED ARE RECYCLABLE</b></p>
Operating and maintenance	<p>Observe the indications contained in this manual to prevent leakage of products that are harmful for the environment. The material used for the packings is free from asbestos fibres, use products with the same features when replacing. Maintenance should be in accordance with the indications of this manual.</p>
Disposal	<p>When the valve life has come to the end it becomes waste and it should be disposed of according to the following indications  <b>DISPOSE ACCORDING TO THE NATIONAL RULES IN FORCE TEMPER WHEN THE VALVE WAS IN CONTACT WITH HARMFUL PRODUCTS PREFERABLY RECYCLE – ALL THE MATERIALS USED ARE RECYCLABLE</b></p>

## 18.11. ANNEX A – NPT assembly instructions

The following steps are applicable to all the NPT connections of the valve (Plugs, End Connections, etc).

STEP-1: Inspect port and fitting to ensure that both are free of contaminants and excessive burrs.

STEP-2: Apply a strip of an anaerobic liquid pipe sealant around the male threads leaving the first two threads uncovered. If no liquid sealant is available, wrap Teflon tape 1-1/2 turns in a clockwise direction, viewed from the pipe end, leaving the first two threads uncovered.

CAUTION: Teflon tape and some pipe sealants are damaging to hydraulic components. Always use extreme caution and follow manufacturer's recommendations for proper application of any sealant to prevent contamination.

STEP 3: Screw finger tight into the port.

STEP 4: Wrench tighten the fitting to the correct turns Past Finger Tight position (See following table). A properly assembled fittings total thread engagement should be 3 to 6 turns.

CAUTION: Never back off an installed pipe fitting to achieve proper alignment. Loosening installed pipe fittings will corrupt the seal and contribute to leakage and failure.

Torque installation of pipe fittings is not a recommended practice. Thread taper and quality, different port and fitting materials, plating thickness and types, varying thread sealants, orientation, and other factors reduce the reliability of a torqued connection. If torque installation is required, refer to the following table for suggested torque values.

<b>NPT TABLE</b>			
<b>ITEM</b>	<b>SCREW SIZE</b>	<b>TURN PAST FINGER TIGHT</b>	<b>TORQUE [Nm]</b>
1	1/8"	1.5 - 3.0	17
2	1/4"	1.5 - 3.0	35
3	3/8"	1.5 - 3.0	55
4	1/2"	1.5 - 3.0	75
5	3/4"	1.5 - 3.0	105
6	1"	1 - 2.5	150
7	1"-1/4	1 - 2.5	210
8	1"-1/2	1 - 2.5	290
9	2"	1 - 2.5	410

## 18.12. ANNEX B – Body bonnet bolt or screw tightening specification

To avoid having bolts over stressed during the valve re-assembly, follow the recommended bolting torques provided here:

<b>BOLTING TORQUE TABLE [Nm]</b>				
<b>IMPERIAL BOLT SIZE</b>	<b>METRIC BOLT SIZE</b>	<b>ALL MATERIALS WITH MIN YIELD STRESS @ ROOM TEMPERATURE OF 400MPa AND BELOW.  ( EG. ASTM A320 B8M CL.1 )</b>	<b>ALL MATERIALS WITH MIN YIELD STRESS @ ROOM TEMPERATURE ABOVE 400MPa.  ( EG. ASTM A320 L7M )</b>	<b>ONLY FOR X5CrNi18.10 (A2-70) 24CrMo5 (G) 21CrMoV57 (GA)</b>
3/8 UNC	M10	<b>16</b>	<b>30</b>	<b>45</b>
1/2 UNC	M12	<b>37</b>	<b>70</b>	<b>75</b>
9/16 UNC	M14	<b>50</b>	<b>95</b>	<b>120</b>
5/8 UNC	M16	<b>70</b>	<b>140</b>	<b>185</b>
3/4 UNC	M20	<b>125</b>	<b>230</b>	<b>260</b>
7/8 UNC	M22	<b>200</b>	<b>370</b>	<b>450</b>
1-UNC	M24	<b>300</b>	<b>550</b>	<b>670</b>

**NOTE:**

- Torque tolerance  $\pm 10\%$ .
- For temperatures above 400°C use 75% of the torque values.
- Torque values are with the bolts lubricated.
- When applying the torque to the bolts, each bolt should be torqued in steps of approximately 20% of the final torque.
- Do not use impacting devices to tighten up the bolting on the body/bonnet. Use suitable mechanical devices for tightening.
- In case of metric bolting use the nearest imperial nominal size available.
- Before installing flange bolts, it is recommend to apply a light coating anti-seize (non-galling, high temperature grease) to the threads of the bolts.

#### FLANGE BOLT TIGHTENING SEQUENCE

To ensure even distribution of stresses in the fully-installed flange, tighten the bolts in a star pattern then repeat the star pattern while tightening to the next torque value, and so on to the maximum torque value.

#### EXAMPLE OF CRISS-CROSS SEQUENCE



up to

## 18.13. ANNEX C- Troubleshooting guide

Failure	Cause	Troubleshooting
Leakage of packing	<ul style="list-style-type: none"> <li>1-Gland flange nuts loose</li> <li>2-Rings of packing insufficient</li> <li>3-Packing aged or failing</li> <li>4-Stem sealing damage</li> </ul>	<ul style="list-style-type: none"> <li>1-Equally tighten gland flange nuts</li> <li>2-Add packing</li> <li>3-Replace packing</li> <li>4-Stem should be maintained in accordance with the correct procedures or replaced according to with the maintenance of pipeline facilities</li> </ul>
Leakage between sealing surface	<ul style="list-style-type: none"> <li>1-Dirt between sealing surfaces</li> <li>2-Sealing surface damaged</li> </ul>	<ul style="list-style-type: none"> <li>1-Clean sealing surface</li> <li>2-Repair the sealing surfaces</li> </ul>
Operation failure	<ul style="list-style-type: none"> <li>1-Packing too tight</li> <li>2-Stem nut over worn</li> <li>3-Stem bent</li> <li>4-Foreign matter between the stem and stem nut or gland or gland flange</li> </ul>	<ul style="list-style-type: none"> <li>1-Properly loosen gland flange nuts</li> <li>2-Replace stem nut</li> <li>3-Rectify or replace stem</li> <li>4-Clean foreign matter</li> </ul>
Leakage between body/bonnet flanges	<ul style="list-style-type: none"> <li>1-Bonnet bolts loose</li> <li>2-Bonnet gasket failure</li> </ul>	<ul style="list-style-type: none"> <li>1-Properly tighten bonnet nuts</li> <li>2-Replace bonnet gasket</li> </ul>
Body and bonnet broken and leaking	<ul style="list-style-type: none"> <li>1-Static head</li> <li>2-Fatigue</li> <li>3-Cracking or breaking from freezing temperatures</li> </ul>	<ul style="list-style-type: none"> <li>1-Careful operation to prevent sudden stopping, pumping and rapid shutting</li> <li>2-Replace valve that exceeds guarantee period or is found with early fatigue defection</li> <li>3-Drain away water in winter when valve is not used</li> </ul>
Disc fails to open	<ul style="list-style-type: none"> <li>1- Disc blocked in the body</li> <li>2- Stem is overheated and blocks the disc</li> </ul>	<ul style="list-style-type: none"> <li>1-Use proper torque</li> <li>2-When the valve is closed and the pipeline is heated, rotate the handwheel slightly counter clockwise at varying intervals</li> </ul>

If the problem persists, you have any questions or need additional information, please do not hesitate to contact Airpack BV.

# Bushehr MEG Plant Project

VENDOR NAME	: Airpack Nederland B.V
EQUIPMENT DESCRIPTION	: Nitrogen & Instrument Booster Package
EQUIPMENT TAGNUMBER	: 20-C-1002, 20-C-7080

## SECTION 19

### PRESSURE REDUCING VALVE



Vendor doc. Number

17811-20

Vendor:

Airpack Nederland B.V.

P.O. NO.:

MEG20-PO-BP303-021

SHEET QTY: 05



## Table of Contents

19	Pressure Control Valve .....	3
19.1	Introduction.....	3
19.2	Precautions .....	4
19.3	Certification .....	5
19.4	Maintenance .....	5

## 19 Pressure Control Valve

### 19.1 Introduction

---

**NOTE**

This valve is intended for a specific range of pressures, temperatures and other application specifications.

Applying different pressures and temperatures to the valve could result in damage to the valve, malfunction of the control valve, or loss of control of the process. Do not expose this product to service conditions or variables other than those for which the product was intended. If you are not sure what these conditions are you should contact Airpack for complete specifications and clarification. Provide the product serial number (shown on the nameplate) and all other pertinent information.

---

The pressure control valve is used to control the pressure of an air or gas system and will be activate through the PLC, computer or microprocessor, which is signalled By a pressure transmitter. For critical pressures it is necessary to monitor the position of the valve. In such cases, a limit/position switch will be mounted (see enclosed data sheet).

## 19.2 Precautions

**WARNING:**

INCORRECT OR IMPROPER USE OF THIS PRODUCT CAN CAUSE SERIOUS PERSONAL INJURY AND PROPERTY DAMAGE.

Due to the variety of operating conditions and applications for this product, the user is solely responsible for making the final proper decisions concerning the correct assembly and functioning of the product and assuring that all the performance, safety and warning requirements are met.

- Users must be trained and equipped for the handling, use, and servicing of (high) pressure products and systems.
- Users must contact their gas or liquid supplier for specific safety precautions and instructions.
- Gaseous media should be free of excessive moisture to prevent icing at high flow.
- Always wear the appropriate protective clothing, including safety glasses, gloves etc. if required.
- Follow the applicable safety and maintenance procedures.
- Obey specific local regulations.
- Do not exceed the maximum inlet and outlet pressure of the product or its accessories.
- Operate within the temperature limits and other conditions specified for the product.
- Do not drop or damage the product in any other way. This may negatively affect the performance of the product and can cause the product to malfunction.
- Venting fluids and gases can be dangerous. Vent to a safe environment away from people. Ensure adequate ventilation in accordance with local regulations.
- This product is not oxygen clean and therefore not suitable for oxygen service.

**WARNING:**

Personal injury could result from packing leakage. Valve packing is tightened before shipment; however the packing might require some readjustment to meet specific service conditions.

## 19.3 Certification

CE mark



This device is designed to meet state-of-the-art safety requirements, has been tested and left the factory in a condition in which it is safe to operate. The device complies with the applicable standards and regulations as listed in the EC declaration of conformity and thus complies with the statutory requirements of the EC Directives.

## 19.4 Maintenance

This product should be checked periodically for proper and safe operation. It is the user's sole responsibility to determine the frequency of maintenance based on the application.

---

### WARNING

Avoid personal injury or property damage from sudden release of process pressure or bursting of parts.

Before performing any maintenance operations:

- Always wear protective gloves, clothing and eyewear when performing any maintenance operations to avoid personal injury.
  - Disconnect any operating lines providing air pressure, electric power or a control signal to the actuator. Be sure the actuator cannot suddenly open or close the valve.
  - Use bypass valve or completely shut off the process to isolate the valve from the process pressure. Relieve the process pressure from both sides of the valve.
  - Depending on the actuator construction, it will be necessary to manage the pneumatic actuator loading pressure and any actuator spring pre-compression. It is essential to refer to the relevant actuator instructions in this manual to ensure safe removal of the actuator from the valve.
  - Use lock-out procedures to be sure that the above measures stay in effect while you work on the equipment.
  - The valve packing box may contain process fluids that are pressurized, even when the valve has been removed from the pipeline.
  - Process fluids may spray out under pressure when removing the packing hardware or packing rings or when loosening the packing box pipe plug.
  - Check with your process or safety engineer for any additional measures that must be taken to protect against process media.
-

# Bushehr MEG Plant Project

<b>VENDOR NAME</b>	: Airpack Nederland B.V
<b>EQUIPMENT DESCRIPTION</b>	: Nitrogen & Instrument Booster Package
<b>EQUIPMENT TAGNUMBER</b>	: 20-C-1002, 20-C-7080

## SECTION 20

### PRESSURE CONTROL VALVE



Vendor doc. Number

17811-20

Vendor:

Airpack Nederland B.V.

P.O. NO.:

MEG20-PO-BP303-021

SHEET QTY: 05



## Table of Contents

20	Pressure Control Valve .....	3
20.1	Introduction.....	3
20.2	Precautions .....	4
20.3	Certification .....	5
20.4	Maintenance .....	5

## 20 Pressure Control Valve

### 20.1 Introduction

---

**NOTE**

This valve is intended for a specific range of pressures, temperatures and other application specifications.

Applying different pressures and temperatures to the valve could result in damage to the valve, malfunction of the control valve, or loss of control of the process. Do not expose this product to service conditions or variables other than those for which the product was intended. If you are not sure what these conditions are you should contact Airpack for complete specifications and clarification. Provide the product serial number (shown on the nameplate) and all other pertinent information.

---

The pressure control valve is used to control the pressure of an air or gas system and will be activate through the PLC, computer or microprocessor, which is signalled By a pressure transmitter. For critical pressures it is necessary to monitor the position of the valve. In such cases, a limit/position switch will be mounted (see enclosed data sheet).

## 20.2 Precautions

**WARNING:**

INCORRECT OR IMPROPER USE OF THIS PRODUCT CAN CAUSE SERIOUS PERSONAL INJURY AND PROPERTY DAMAGE.

Due to the variety of operating conditions and applications for this product, the user is solely responsible for making the final proper decisions concerning the correct assembly and functioning of the product and assuring that all the performance, safety and warning requirements are met.

- Users must be trained and equipped for the handling, use, and servicing of (high) pressure products and systems.
- Users must contact their gas or liquid supplier for specific safety precautions and instructions.
- Gaseous media should be free of excessive moisture to prevent icing at high flow.
- Always wear the appropriate protective clothing, including safety glasses, gloves etc. if required.
- Follow the applicable safety and maintenance procedures.
- Obey specific local regulations.
- Do not exceed the maximum inlet and outlet pressure of the product or its accessories.
- Operate within the temperature limits and other conditions specified for the product.
- Do not drop or damage the product in any other way. This may negatively affect the performance of the product and can cause the product to malfunction.
- Venting fluids and gases can be dangerous. Vent to a safe environment away from people. Ensure adequate ventilation in accordance with local regulations.
- This product is not oxygen clean and therefore not suitable for oxygen service.

**WARNING:**

Personal injury could result from packing leakage. Valve packing is tightened before shipment; however the packing might require some readjustment to meet specific service conditions.

## 20.3 Certification

CE mark



This device is designed to meet state-of-the-art safety requirements, has been tested and left the factory in a condition in which it is safe to operate. The device complies with the applicable standards and regulations as listed in the EC declaration of conformity and thus complies with the statutory requirements of the EC Directives.

## 20.4 Maintenance

This product should be checked periodically for proper and safe operation. It is the user's sole responsibility to determine the frequency of maintenance based on the application.

---

### WARNING

Avoid personal injury or property damage from sudden release of process pressure or bursting of parts.

Before performing any maintenance operations:

- Always wear protective gloves, clothing and eyewear when performing any maintenance operations to avoid personal injury.
  - Disconnect any operating lines providing air pressure, electric power or a control signal to the actuator. Be sure the actuator cannot suddenly open or close the valve.
  - Use bypass valve or completely shut off the process to isolate the valve from the process pressure. Relieve the process pressure from both sides of the valve.
  - Depending on the actuator construction, it will be necessary to manage the pneumatic actuator loading pressure and any actuator spring pre-compression. It is essential to refer to the relevant actuator instructions in this manual to ensure safe removal of the actuator from the valve.
  - Use lock-out procedures to be sure that the above measures stay in effect while you work on the equipment.
  - The valve packing box may contain process fluids that are pressurized, even when the valve has been removed from the pipeline.
  - Process fluids may spray out under pressure when removing the packing hardware or packing rings or when loosening the packing box pipe plug.
  - Check with your process or safety engineer for any additional measures that must be taken to protect against process media.
-

# Bushehr MEG Plant Project

VENDOR NAME	: Airpack Nederland B.V
EQUIPMENT DESCRIPTION	: Nitrogen & Instrument Booster Package
EQUIPMENT TAGNUMBER	: 20-C-1002, 20-C-7080

## SECTION 21

## CHECK VALVE



Vendor doc. Number

17811-20

Vendor:

Airpack Nederland B.V.

P.O. NO.:

MEG20-PO-BP303-021

SHEET QTY: 04



## Table of Contents

21	Check valve.....	3
21.1	Introduction .....	3
21.2	Precautions .....	3
21.3	Certification .....	3
21.4	Maintenance.....	4
21.5	Installation .....	4

## 21 Check valve

### 21.1 Introduction

**NOTE:**

This valve is intended for a specific range of pressures, temperatures and other application specifications.

Applying different pressures and temperatures to the valve could result in damage to the valve, malfunction of the control valve, or loss of control of the process. Do not expose this product to service conditions or variables other than those for which the product was intended. If you are not sure what these conditions are you should contact Airpack for complete specifications and clarification. Provide the product serial number (shown on the nameplate) and all other pertinent information.

### 21.2 Precautions

**WARNING:**

INCORRECT OR IMPROPER USE OF THIS PRODUCT CAN CAUSE SERIOUS PERSONAL INJURY AND PROPERTY DAMAGE.

**WARNING**

Devices from the manufacturer may only be installed, commissioned, operated and maintained by properly trained and authorized personnel.

This document is provided to help you establish operating conditions, which will permit safe and efficient use of this device.

### 21.3 Certification

CE mark



This device is designed to meet state-of-the-art safety requirements, has been tested and left the factory in a condition in which it is safe to operate. The device complies with the applicable standards and regulations as listed in the EC declaration of conformity and thus complies with the statutory requirements of the EC Directives.

## 21.4 Maintenance

### PREVENTIVE MAINTENANCE

All valve components have been designed to be largely maintenance free. The material of the moving parts has been selected for minimum wear. However malfunction caused by wrong operation, lack of maintenance or improper use reduces valve life. All repair and maintenance work shall be performed by qualified personnel following all safety instructions. Maintenance intervals should be selected by the valve user in compliance with the application condition.

## 21.5 Installation

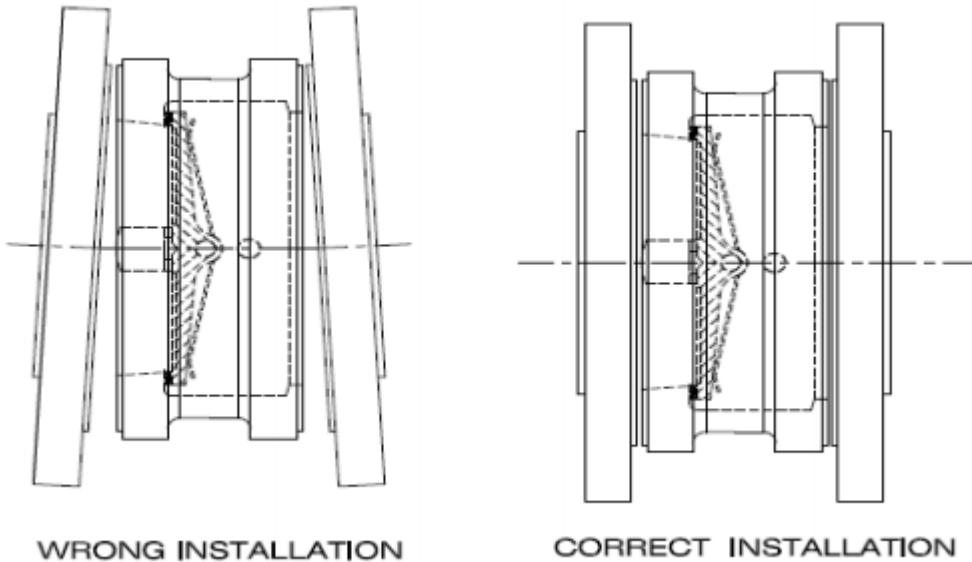

On the housing of the checkvalve, the correct flow direction has been mentioned, always check the flow direction before installing the checkvalve.

Ensure to properly align the flanges before tensioning the studbolts, otherwise the checkvalve will be damaged.

# Bushehr MEG Plant Project

<b>VENDOR NAME</b>	: Airpack Nederland B.V
<b>EQUIPMENT DESCRIPTION</b>	: Nitrogen & Instrument Booster Package
<b>EQUIPMENT TAGNUMBER</b>	: 20-C-1002, 20-C-7080

## SECTION 22

### OVERALL SPARE PART LIST



Vendor doc. Number

17811-20

Vendor:

Airpack Nederland B.V.

P.O. NO.:

MEG20-PO-BP303-021

SHEET QTY: 143

## **Spare parts list for for nitrogen gas booster**

# Nitrogen gas booster compressor

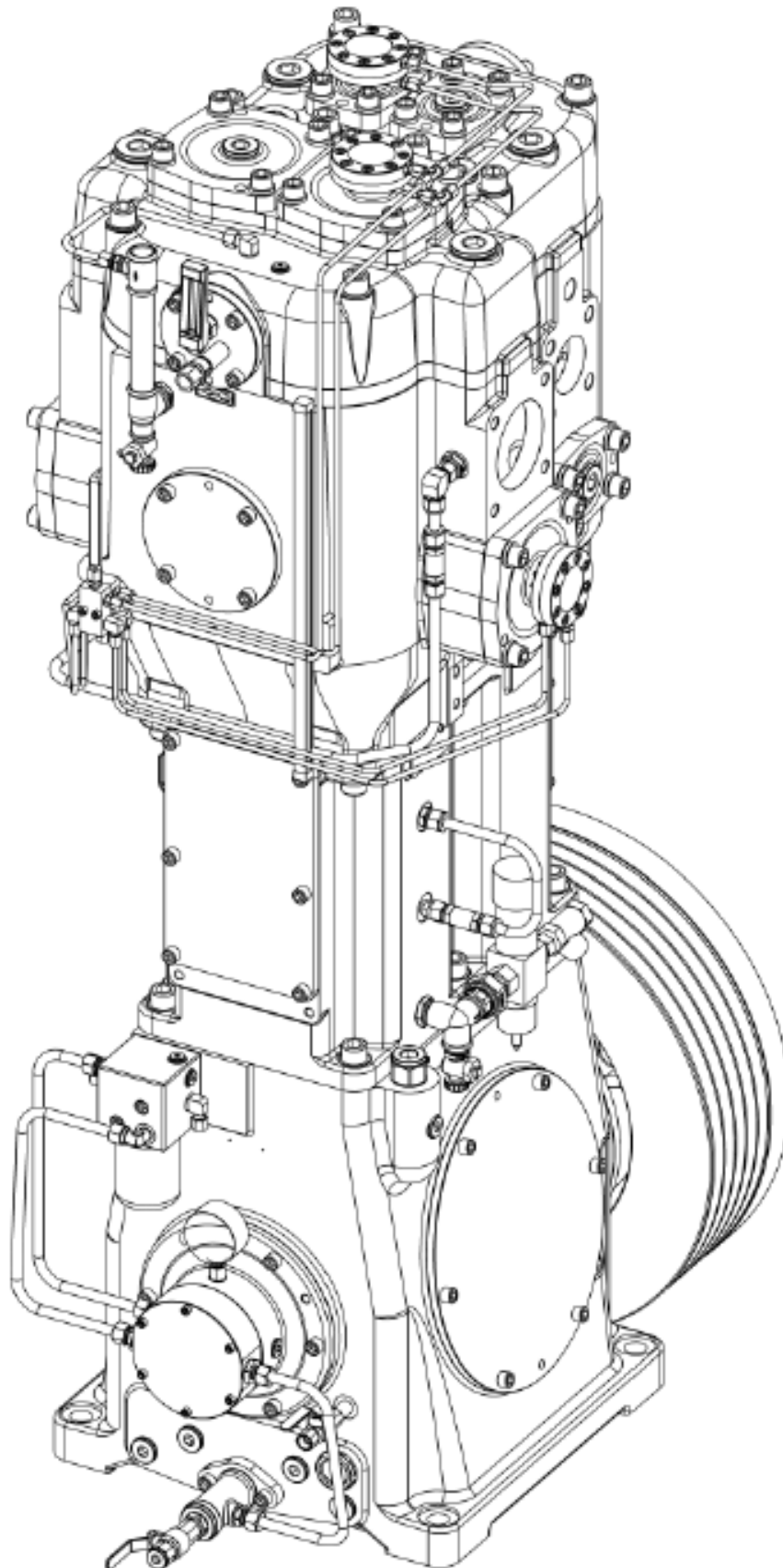

# Drawing CC0800 Compressor

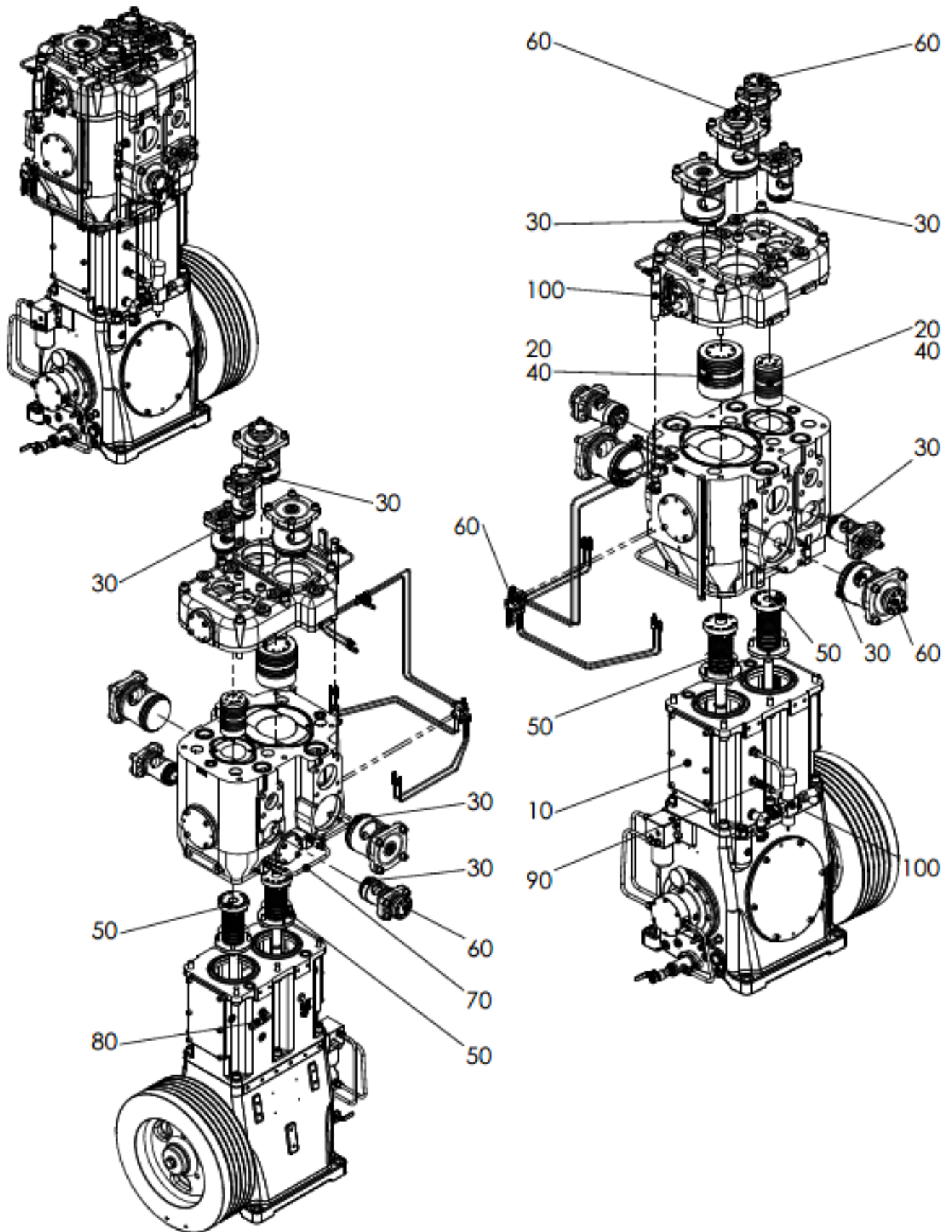



# Drawing CC0801 Compressor

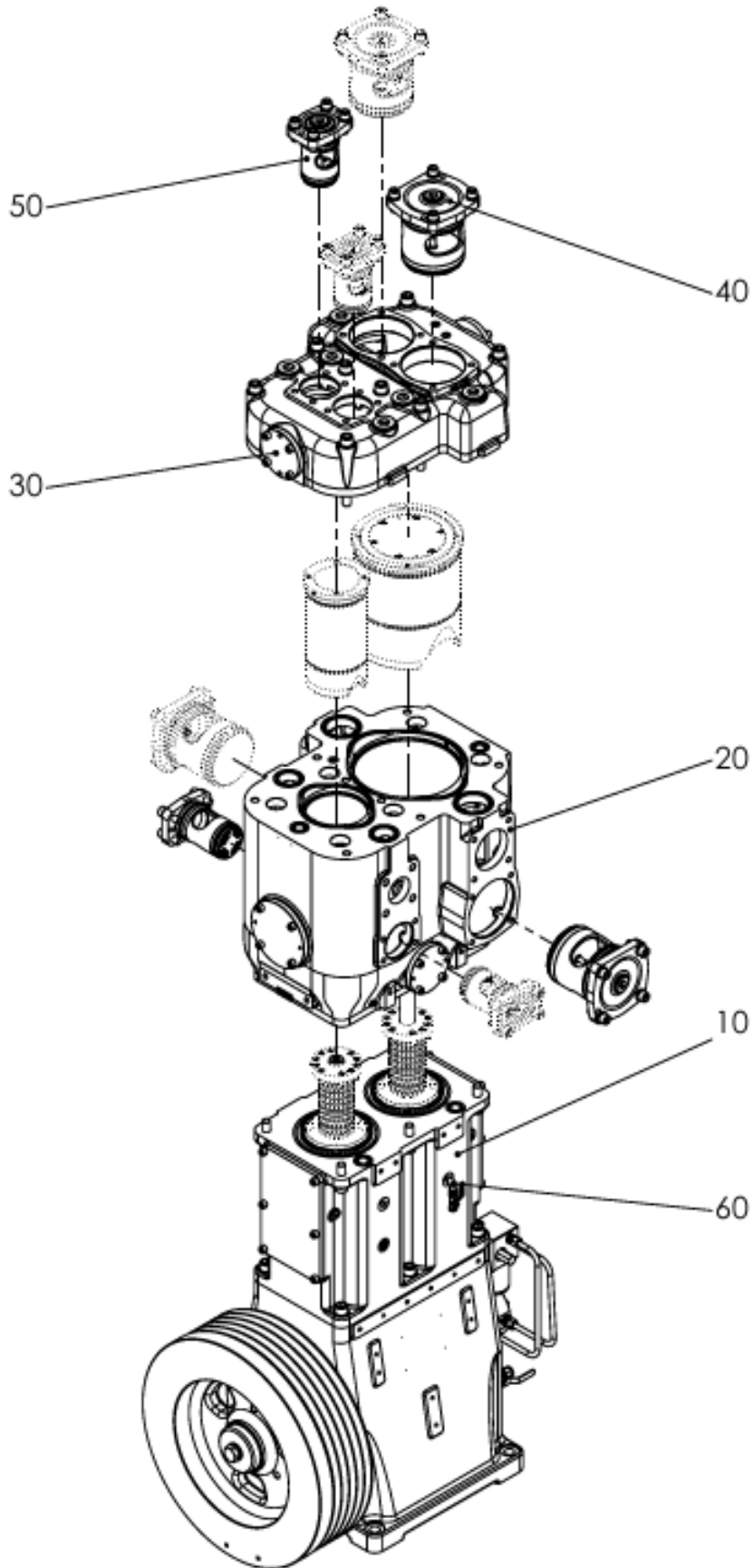

<b>ITEM</b>	<b>PART NO.</b>	<b>DESCRIPTION</b>	<b>QTY</b>
<b>TAG NO.</b>			
		<b>Drawing CC0801 Compressor</b>	
10	17811-CC0812	Gear	1
20	17811-CC0813	Cylinder	1
30	17811-CC0814	Cylinder head	1
40	17811-CC0815	Delivery valve fastening	2
50	17811-CC0816	Delivery valve fastening	2
60	17811-CC0817	Condensate drain	1

# Drawing CC0802 Gear

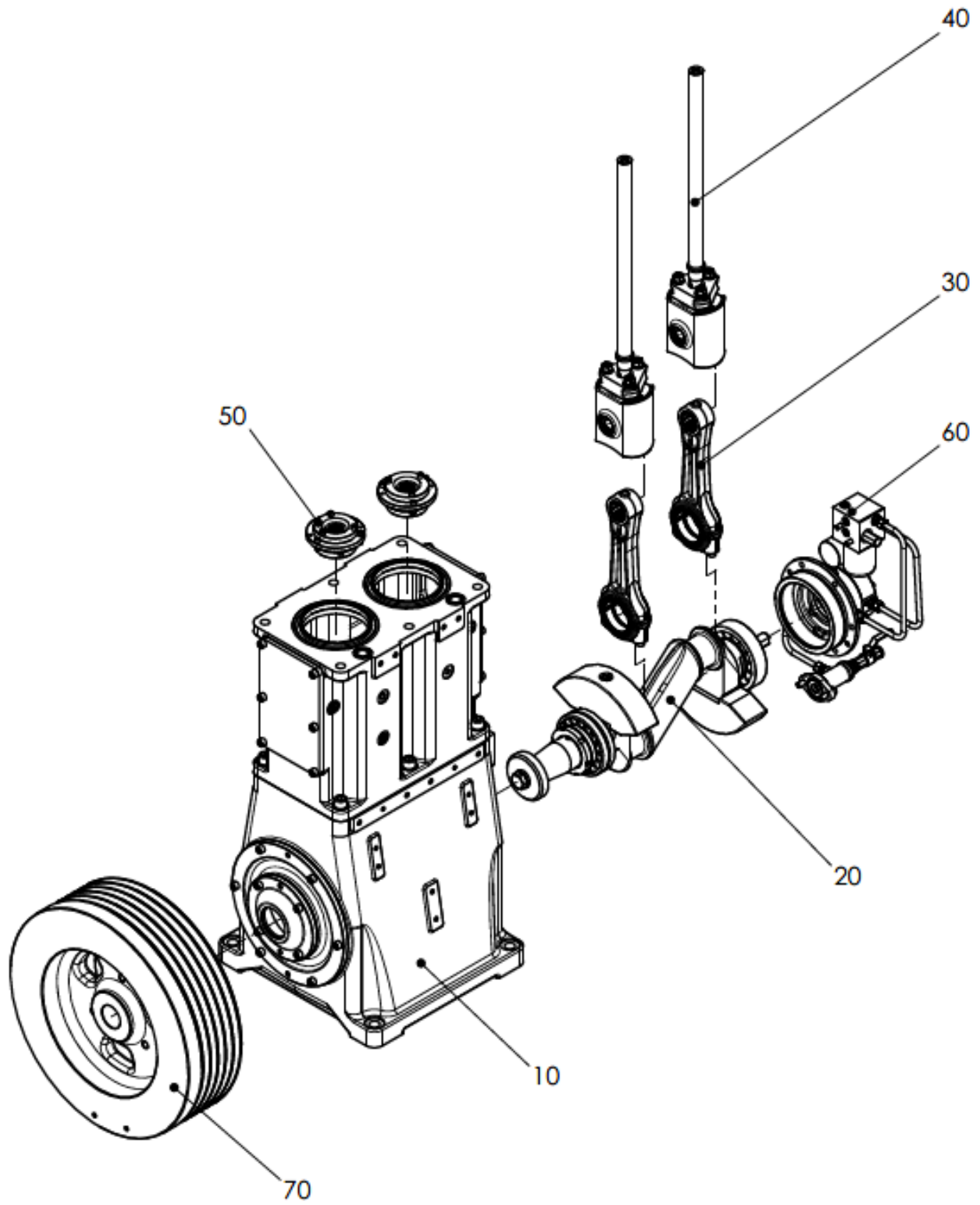

<b>ITEM</b>	<b>PART NO.</b>	<b>DESCRIPTION</b>	<b>QTY</b>
<b>TAG NO.</b>			
		<b>Drawing CC0802 Gear</b>	
10	17811-CC0818	Crankcase	1
20	17811-CC0819	Crankshaft	1
30	17811-CC0820	Connecting rod	2
40	17811-CC0821	Guide piston	2
50	17811-CC0822	Gland oil	2
60	17811-CC0823	Lubrication	1
70	17811-CC0824	V-belt pulley	1
80	17811-CC0825	Oil	13,5

# Drawing CC0803 Crankcase

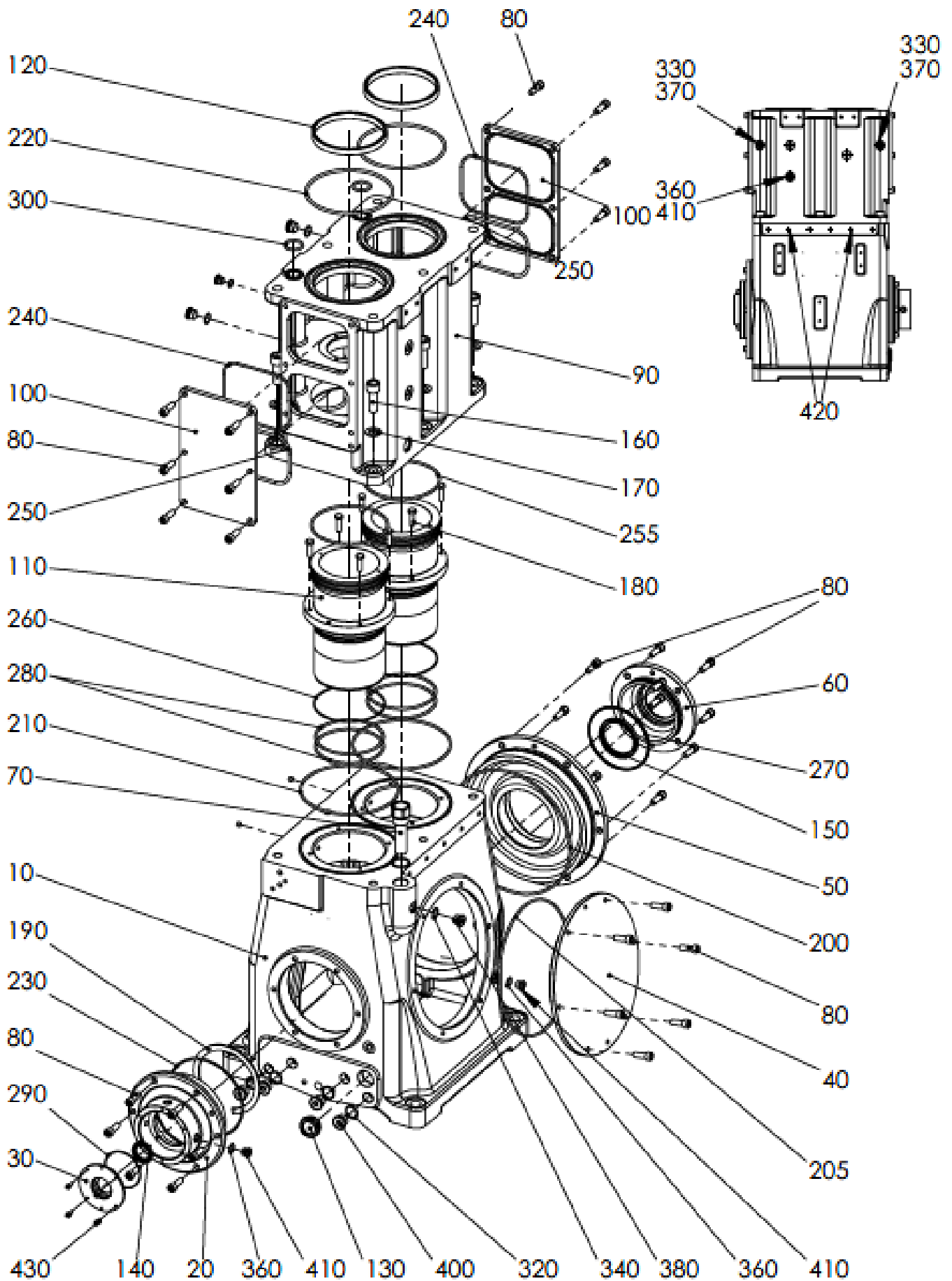

<b>ITEM TAG NO.</b>	<b>PART NO.</b>	<b>DESCRIPTION</b>	<b>QTY</b>
		<b>Drawing CC0803 Crankcase</b>	
10	17811-CC0826	Crankcase	1
20	17811-CC0827	Bearing cap	1
30	17811-CC0828	Cover	1
40	17811-CC0829	Side cover	1
50	17811-CC0830	Bearing cap	1
60	17811-CC0831	Cover	1
70	17811-CC0832	Connection piece	1
80	17811-CC0833	Hexagon socket h.c. screw	34
90	17811-CC0834	Lantern	1
100	17811-CC0835	Side cover	2
110	17811-CC0836	Liner	2
120	17811-CC0837	Ring	2
130	17811-CC0838	Oil inspection glass	1
140	17811-CC0839	Radial oil seal gasket	1
150	17811-CC0840	Radial oil seal gasket	1
160	17811-CC0841	Hexagon socket h.c. screw	6
170	17811-CC0842	Washer	6
180	17811-CC0843	Hexagon screw	8
190	17811-CC0844	Circlip	1
200	17811-CC0845	O-ring	1
205	17811-CC0846	O-ring	1
210	17811-CC0847	O-ring	2
220	17811-CC0848	O-ring	2
230	17811-CC0849	O-ring	1
240	17811-CC0850	O-ring	2
250	17811-CC0851	O-ring	2
255	17811-CC0852	O-ring	2
260	17811-CC0853	O-ring	2
270	17811-CC0854	O-ring	1
280	17811-CC0855	O-ring	4
290	17811-CC0856	O-ring	1
300	17811-CC0857	O-ring	2
320	17811-CC0858	Sealing ring	4
330	17811-CC0859	Sealing ring	2
340	17811-CC0860	Sealing ring	1
360	17811-CC0861	Sealing ring	3
370	17811-CC0862	Plug	2
380	17811-CC0863	Plug	1
400	17811-CC0864	Screw plug	4
410	17811-CC0865	Screw plug	3
420	17811-CC0866	Plug	2
430	17811-CC0867	Hexagon socket h.c. screw	4

# Drawing CC0804 Crankshaft

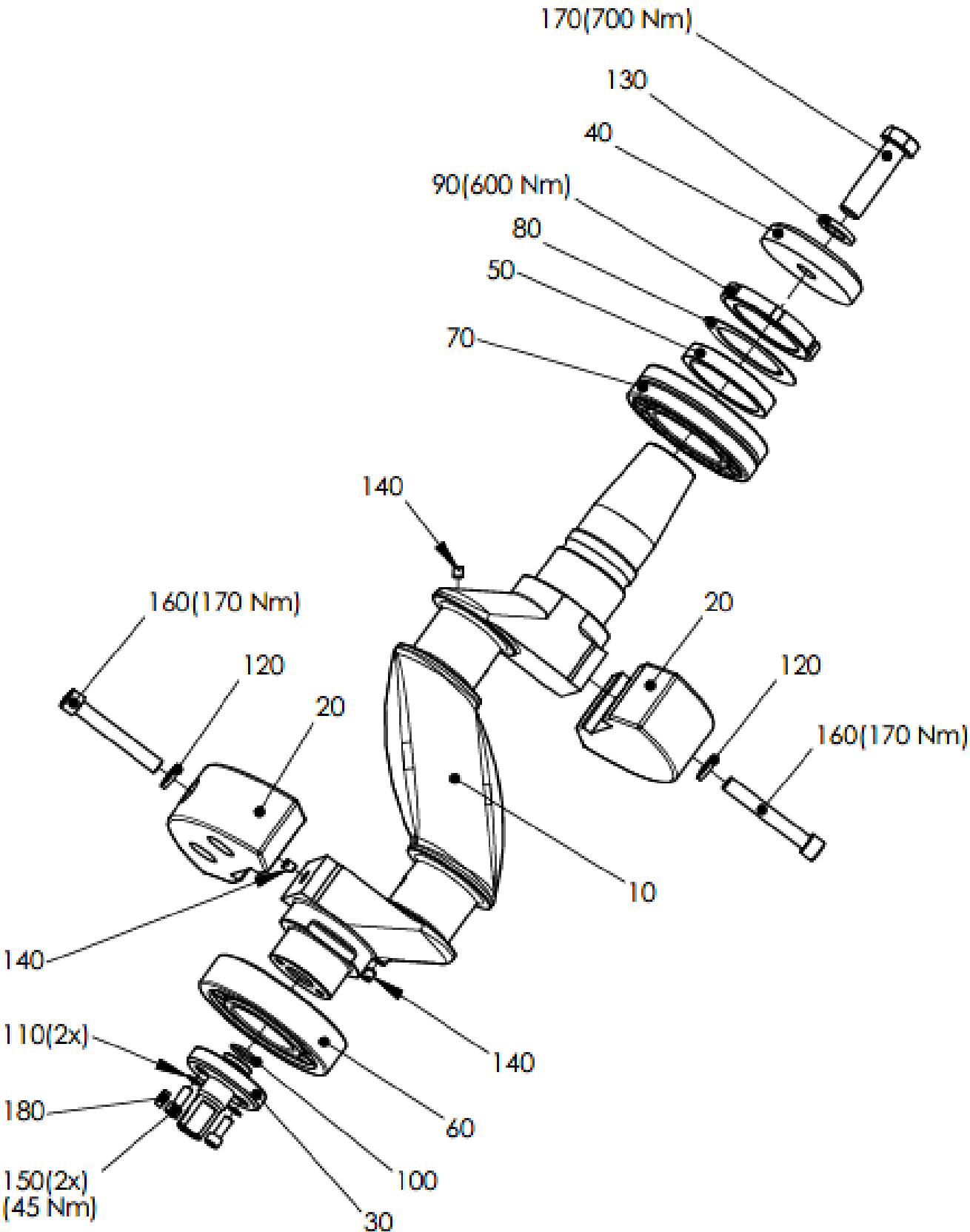

<b>ITEM</b>	<b>PART NO.</b>	<b>DESCRIPTION</b>	<b>QTY</b>
<b>TAG NO.</b>			
		<b>Drawing CC0804 Crankshaft</b>	
10	17811-CC0868	Crankshaft	1
20	17811-CC0869	Counter balance	2
30	17811-CC0870	Washer	1
40	17811-CC0871	Washer	1
50	17811-CC0872	Distance ring	1
60	17811-CC0873	Roller bearing	1
70	17811-CC0874	Self-aligning roller bearing	1
80	17811-CC0875	Tab washer	1
90	17811-CC0876	Groove nut	1
100	17811-CC0877	O-ring	1
110	17811-CC0878	Lock plate	2
120	17811-CC0879	Lock plate	2
130	17811-CC0880	Lock plate	1
140	17811-CC0881	Set screw	3
150	17811-CC0882	Hexagon socket h.c. screw	2
160	17811-CC0883	Hexagon socket h.c. screw	2
170	17811-CC0884	Hexagon screw	1
180	17811-CC0885	Feather key	1

# Drawing CC0805 Guide piston

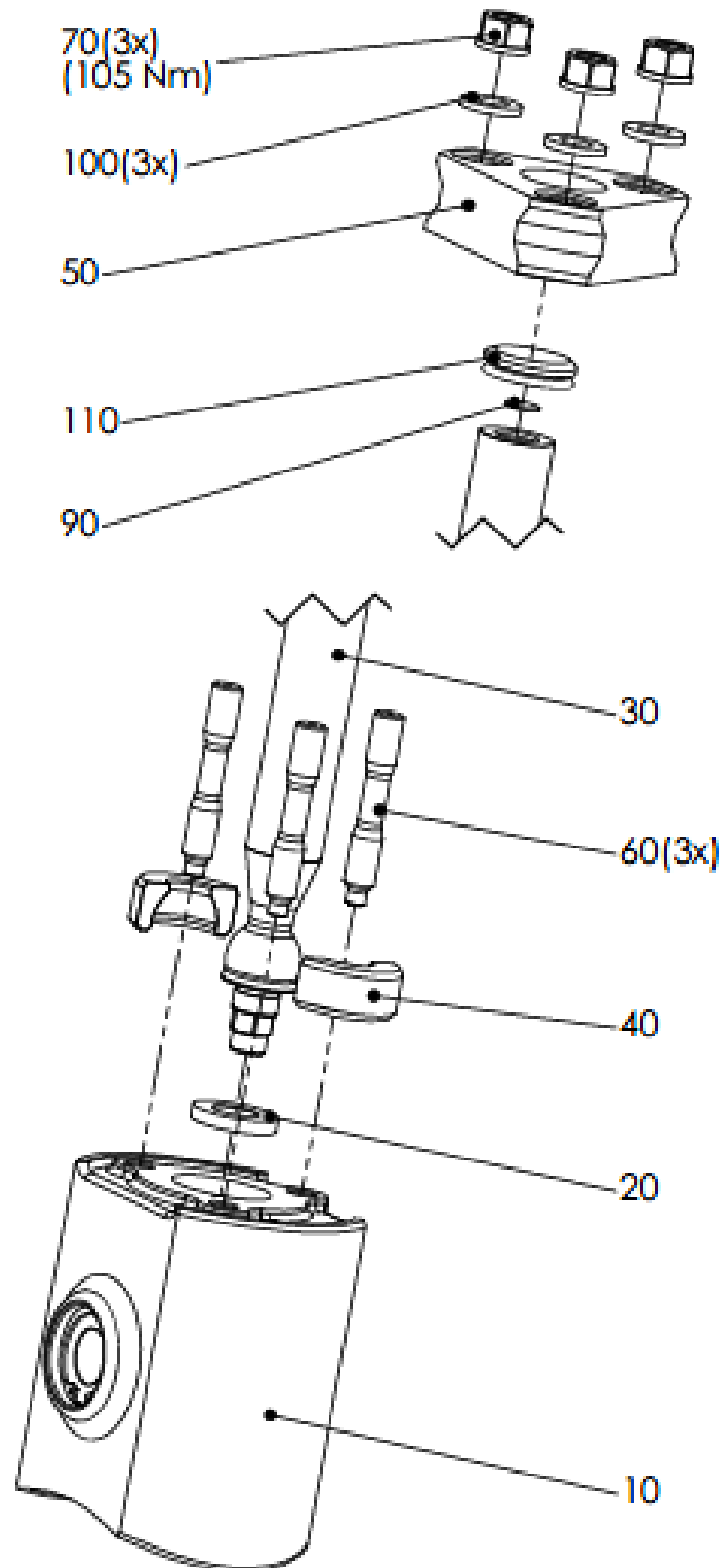

<b>ITEM</b>	<b>PART NO.</b>	<b>DESCRIPTION</b>	<b>QTY</b>
<b>TAG NO.</b>			
		<b>Drawing CC0805 Guide piston</b>	
10	17811-CC0886	Guide piston	1
20	17811-CC0887	Pressure washer	1
30	17811-CC0888	Piston rod	1
40	17811-CC0889	Ring	1
50	17811-CC0890	Ring	1
60	17811-CC0891	Screw	3
70	17811-CC0892	Nut	3
90	17811-CC0893	Washer	1
100	17811-CC0894	Lock plate	3
110	17811-CC0895	V-Ring	1

# Drawing CC0806 Gland, oil

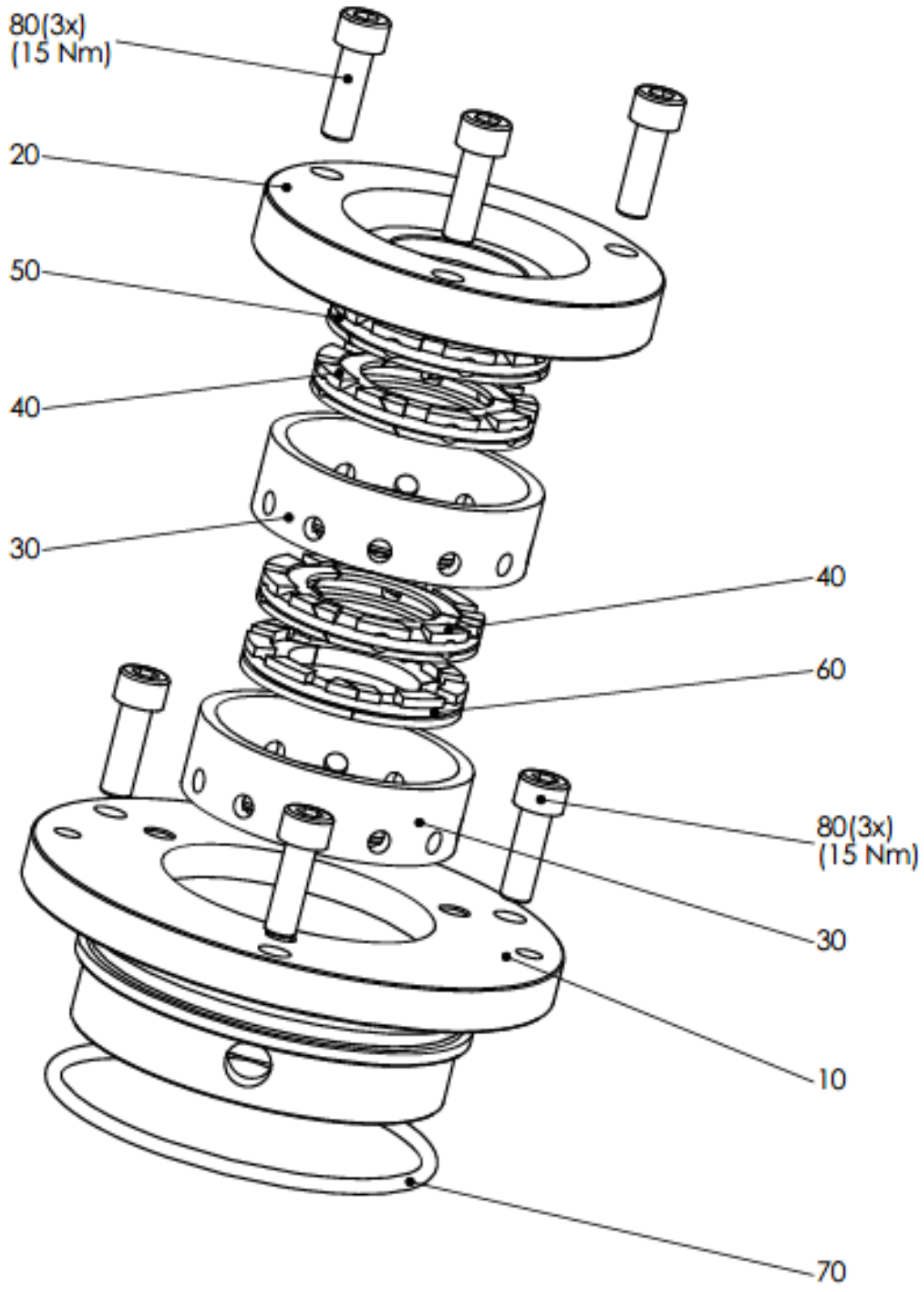

<b>ITEM</b>	<b>PART NO.</b>	<b>DESCRIPTION</b>	<b>QTY</b>
<b>TAG NO.</b>			
		<b>Drawing CC0806 Gland oil</b>	
10	17811-CC0896	Gland housing	1
20	17811-CC0897	Cover	1
30	17811-CC0898	Gland chamber	2
40	17811-CC0899	Oil scraper ring	2
50	17811-CC0900	Oil scraper ring	1
60	17811-CC0901	Oil scraper ring	1
70	17811-CC0902	O-ring	1
80	17811-CC0903	Hexagon socket h.c. screw	6

# Drawing CC0807 Lubrication

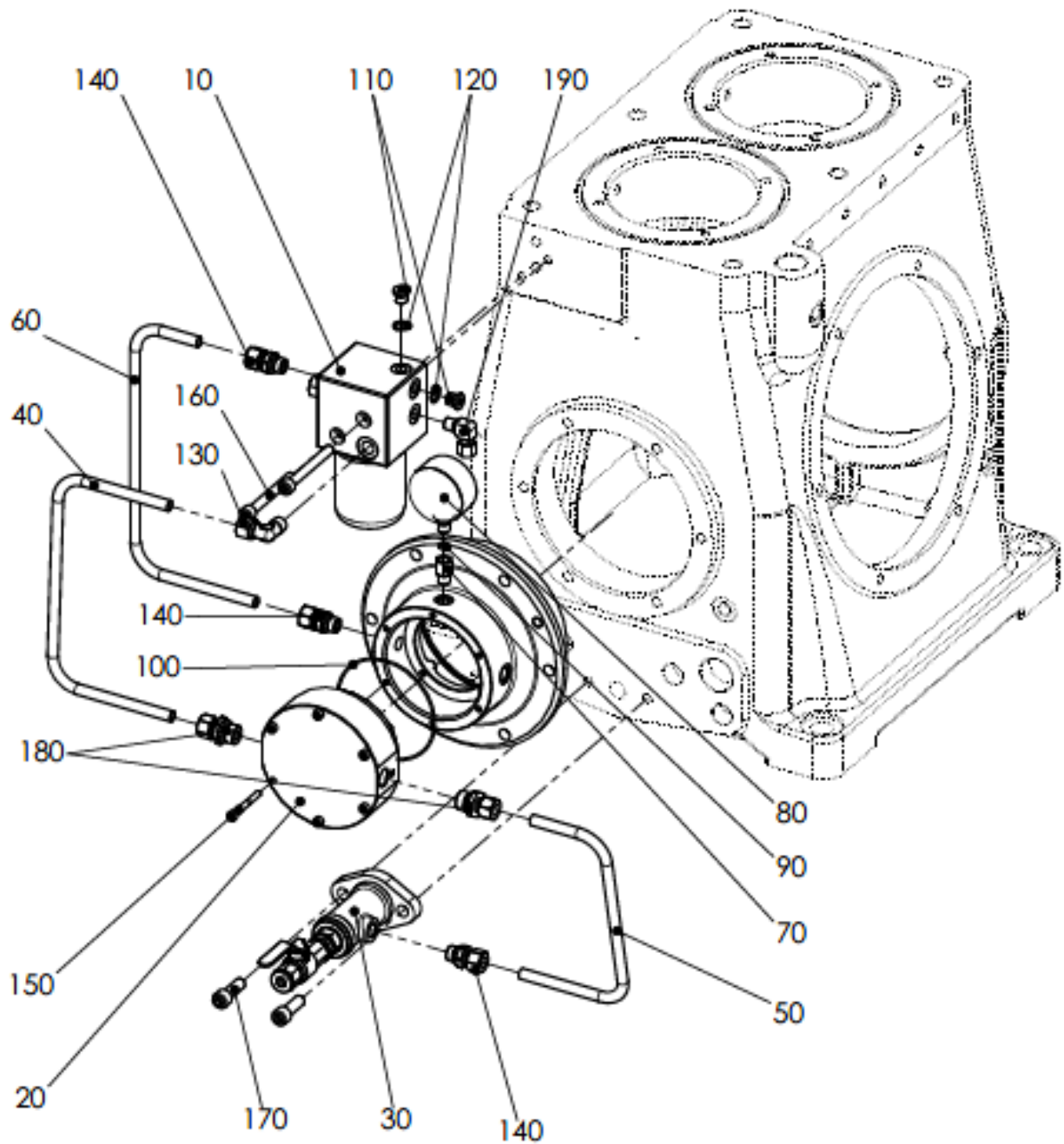

<b>ITEM</b>	<b>PART NO.</b>	<b>DESCRIPTION</b>	<b>QTY</b>
<b>TAG NO.</b>			
		<b>Drawing CC0807 Lubrication</b>	
10	17811-CC0904	Pressure regulator	1
20	17811-CC0905	Pump	1
30	17811-CC0906	Filter	1
40	17811-CC0907	Pipeline	1
50	17811-CC0908	Pipeline	1
60	17811-CC0909	Pipeline	1
70	17811-CC0910	Socket	1
80	17811-CC0911	Manometer	1
90	17811-CC0912	Sealing ring	1
100	17811-CC0913	O-ring	1
110	17811-CC0914	Screw plug	2
120	17811-CC0915	Sealing ring	2
130	17811-CC0916	Angular threaded joint	1
140	17811-CC0917	Straight screw connection	3
150	17811-CC0918	Hexagon socket h.c. screw	6
160	17811-CC0919	Hexagon socket h.c. screw	2
170	17811-CC0920	Hexagon socket h.c. screw	2
180	17811-CC0921	Straight screw connection	2
190	17811-CC0922	Angular threaded joint	1

# Drawing CC0808 Pressure regulator

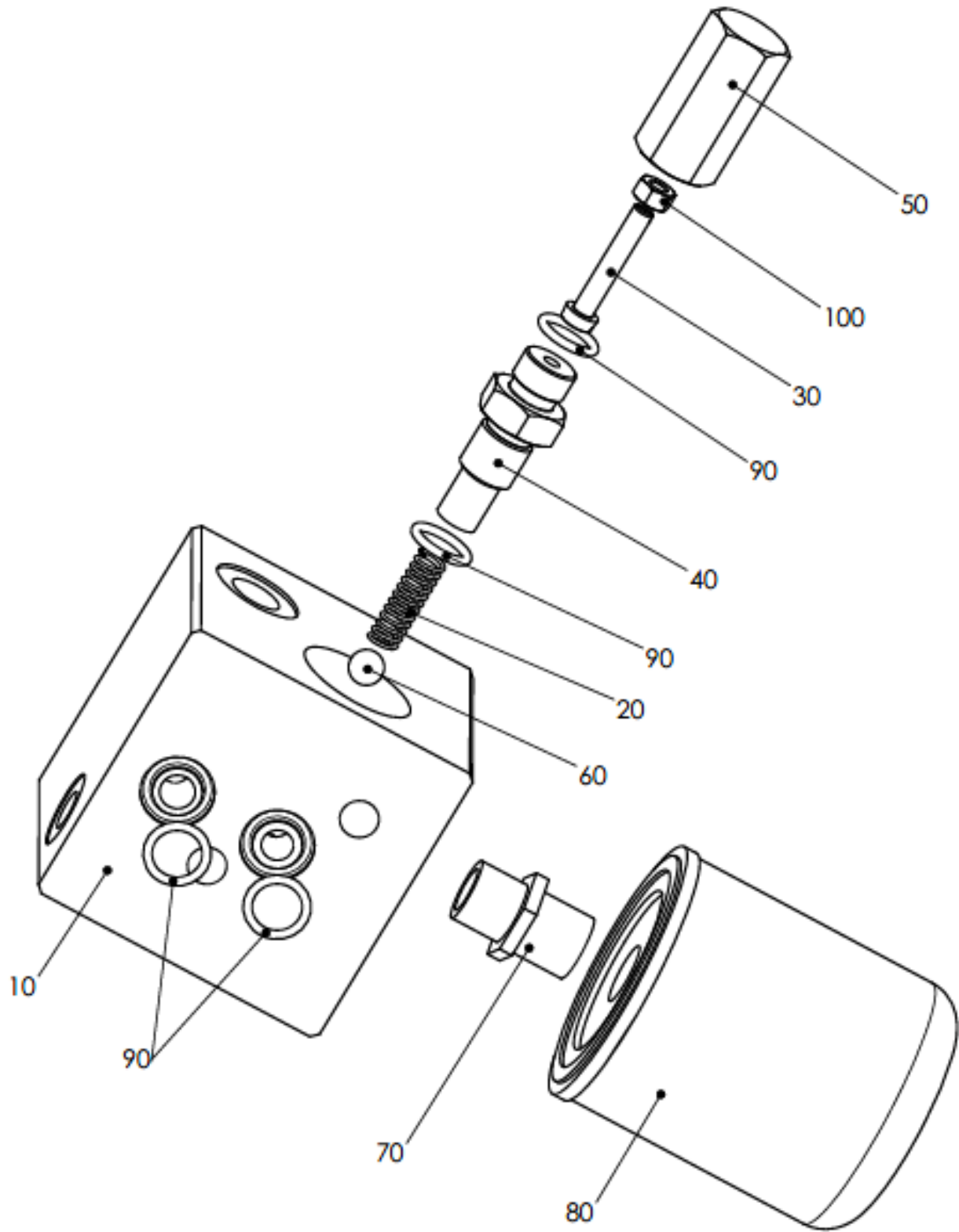

<b>ITEM</b>	<b>PART NO.</b>	<b>DESCRIPTION</b>	<b>QTY</b>
<b>TAG NO.</b>			
		<b>Drawing CC0808 Pressure regulator</b>	
10	17811-CC0923	Distributor	1
20	17811-CC0924	Pressure spring	1
30	17811-CC0925	Adjusting screw	1
40	17811-CC0926	Valve guide	1
50	17811-CC0927	Cap nut	1
60	17811-CC0928	Ball	1
70	17811-CC0929	Nipple	1
80	17811-CC0930	Filter element	1
90	17811-CC0931	O-ring	4
100	17811-CC0932	Hexagon nut	1

# Drawing CC0809 Cylinder

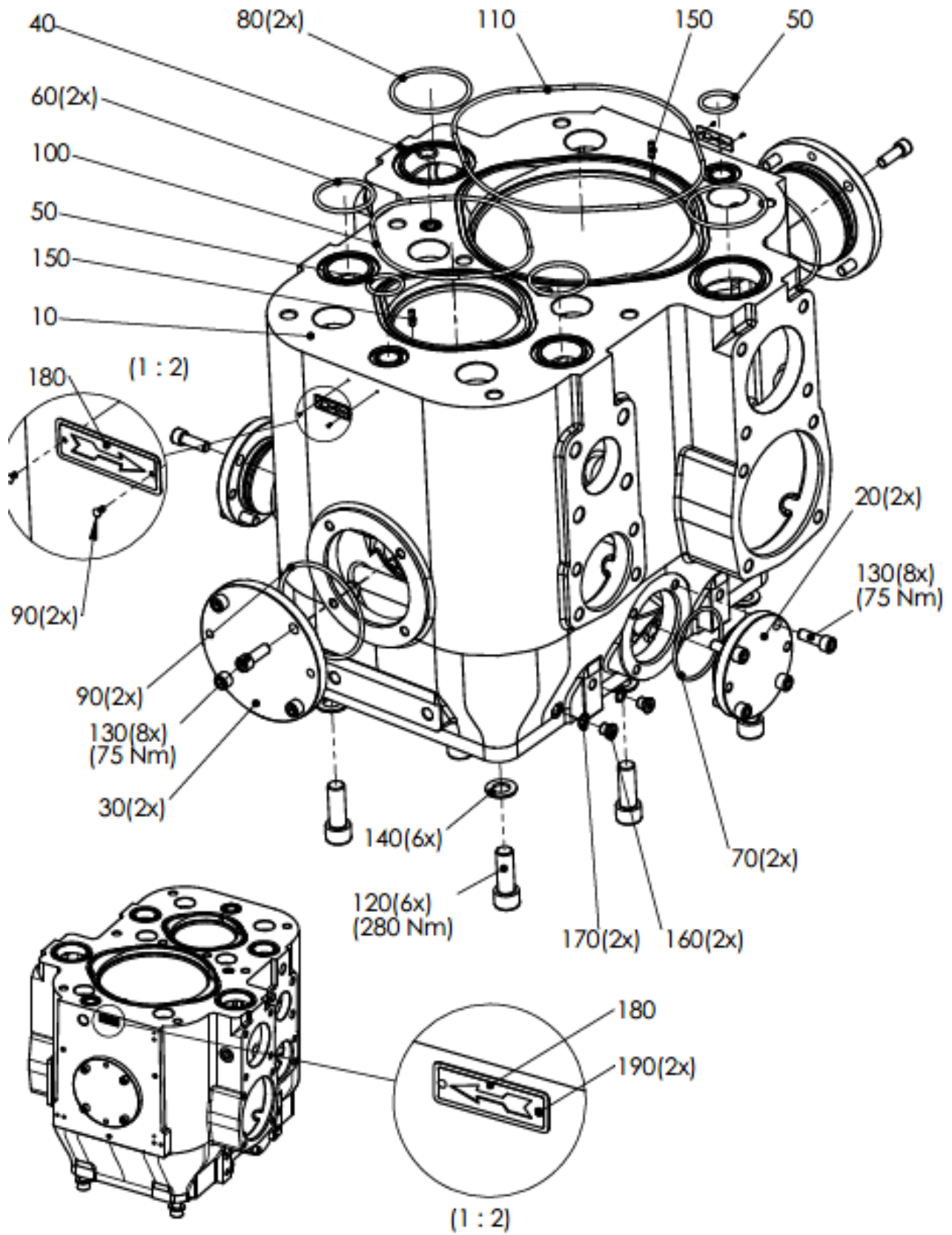

<b>ITEM</b>	<b>PART NO.</b>	<b>DESCRIPTION</b>	<b>QTY</b>
<b>TAG NO.</b>			
		<b>Drawing CC0809 Cylinder</b>	
10	17811-CC0933	Cylinder	1
20	17811-CC0934	Cover	2
30	17811-CC0935	Side cover	2
40	17811-CC0936	O-ring	1
50	17811-CC0937	O-ring	2
60	17811-CC0938	O-ring	2
70	17811-CC0939	O-ring	2
80	17811-CC0940	O-ring	2
90	17811-CC0941	O-ring	2
100	17811-CC0942	O-ring	1
110	17811-CC0943	O-ring	1
120	17811-CC0944	Hexagon socket h.c. screw	6
130	17811-CC0945	Hexagon socket h.c. screw	16
140	17811-CC0946	Washer	6
150	17811-CC0947	Straight pin	2
160	17811-CC0948	Screw plug	2
170	17811-CC0949	Sealing ring	2
180	17811-CC0950	Plate	2
190	17811-CC0951	Round head bolt	4

# Drawing CC0810 Cylinder head

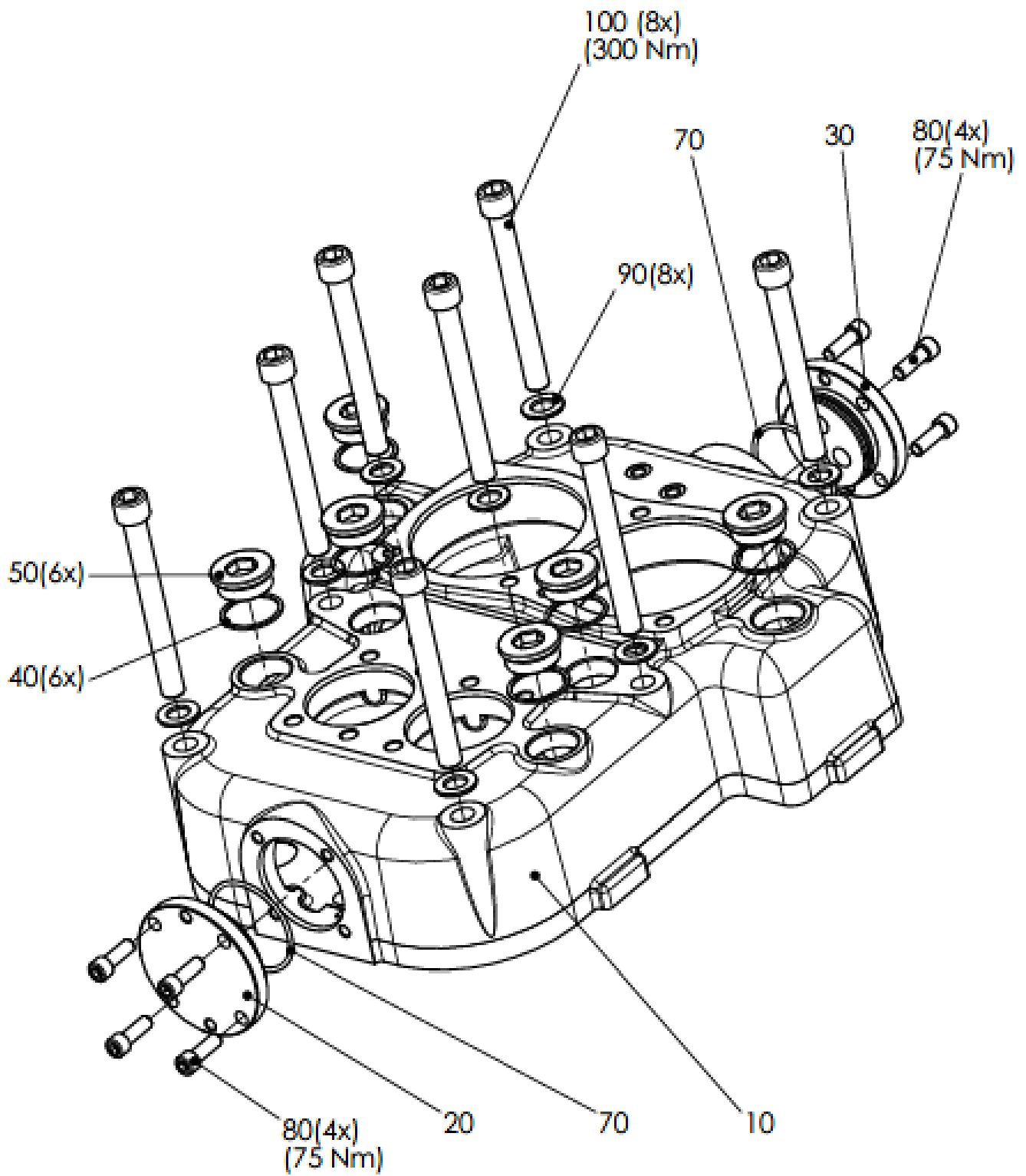

<b>ITEM</b>	<b>PART NO.</b>	<b>DESCRIPTION</b>	<b>QTY</b>
<b>TAG NO.</b>			
		<b>Drawing CC0810 Cylinder head</b>	
10	17811-CC0952	Cylinder head	1
20	17811-CC0953	Cover	1
30	17811-CC0954	Cover	<u>1</u>
40	17811-CC0955	Sealing ring	6
50	17811-CC0956	Screw plug	6
70	17811-CC0957	O-ring	2
80	17811-CC0958	Hexagon socket h.c. screw	8
90	17811-CC0959	Washer	8
100	17811-CC0960	Hexagon socket h.c. screw	8

# Drawing CC0811 Delivery valve fastening

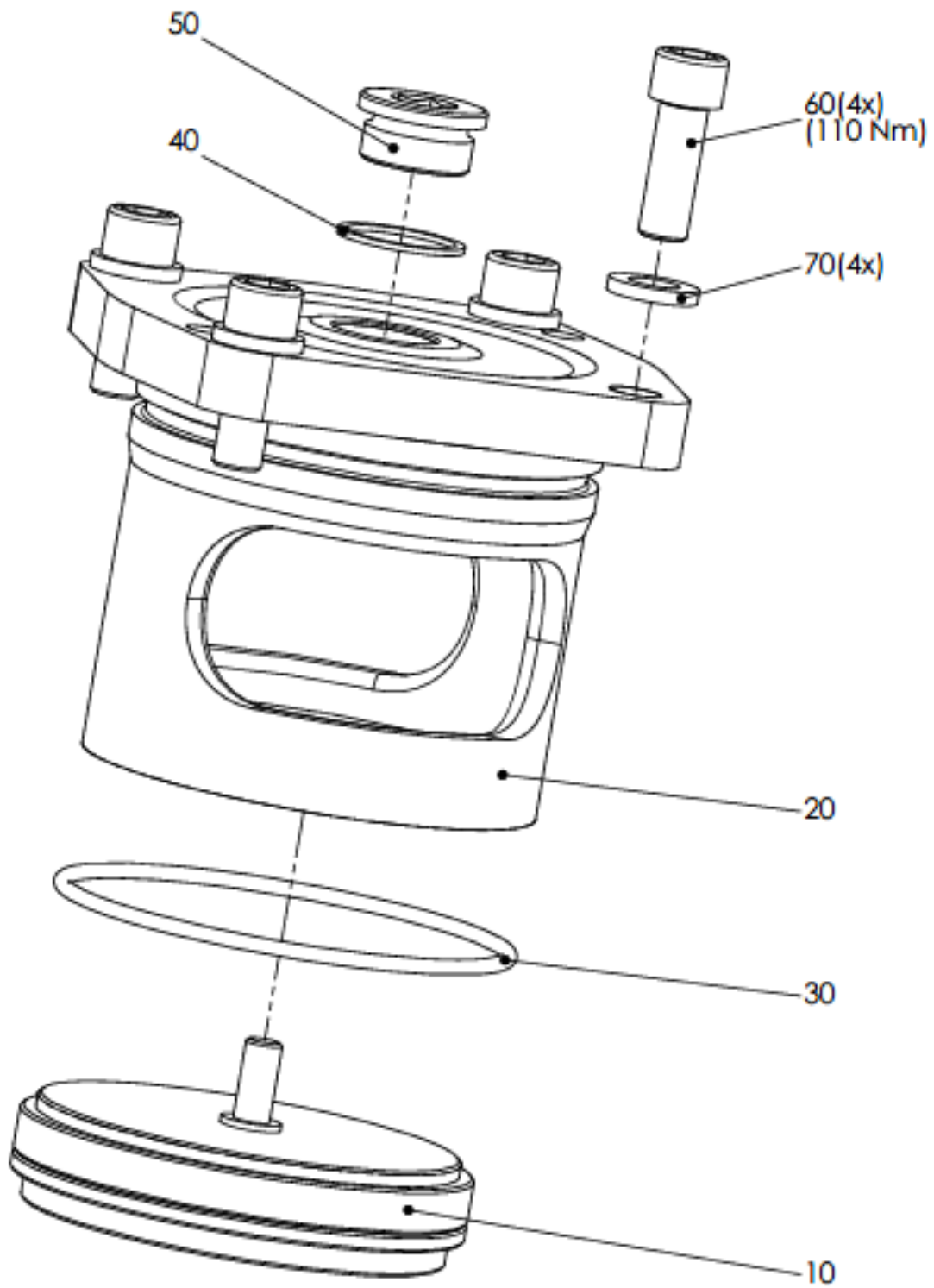

<b>ITEM</b>	<b>PART NO.</b>	<b>DESCRIPTION</b>	<b>QTY</b>
<b>TAG NO.</b>			
		<b>Drawing CC0811 Delivery valve fastening</b>	
10	17811-CC0961	see 1.assy Pos. 30.2 resp. 30	1
20	17811-CC0962	Valve lantern	1
30	17811-CC0963	O-ring	1
40	17811-CC0964	Sealing ring	1
50	17811-CC0965	Screw plug	1
60	17811-CC0966	Hexagon socket h.c. screw	4
70	17811-CC0967	Lock plate	4

# Drawing CC0812 Delivery valve fastening

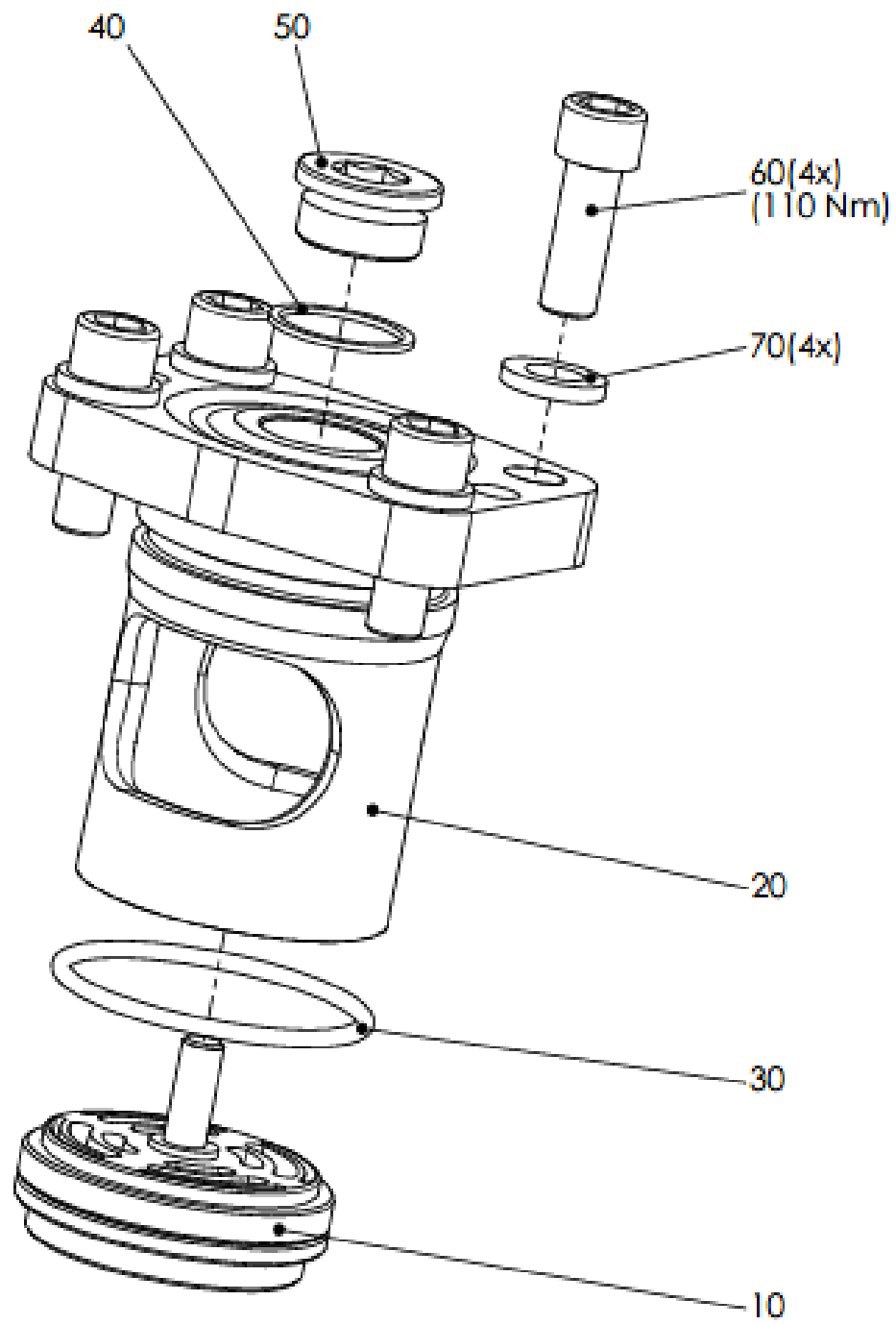

<b>ITEM</b>	<b>PART NO.</b>	<b>DESCRIPTION</b>	<b>QTY</b>
<b>TAG NO.</b>			
		<b>Drawing CC0812 Delivery valve fastening</b>	
10	17811-CC0968	see 1.assy Pos.30.4 resp. 30	1
20	17811-CC0969	Valve lantern	1
30	17811-CC0970	O-ring	1
40	17811-CC0971	Sealing ring	1
50	17811-CC0972	Screw plug	1
60	17811-CC0973	Hexagon socket h.c. screw	4
70	17811-CC0974	Lock plate	4

Drawing CC0813 Condensate drain

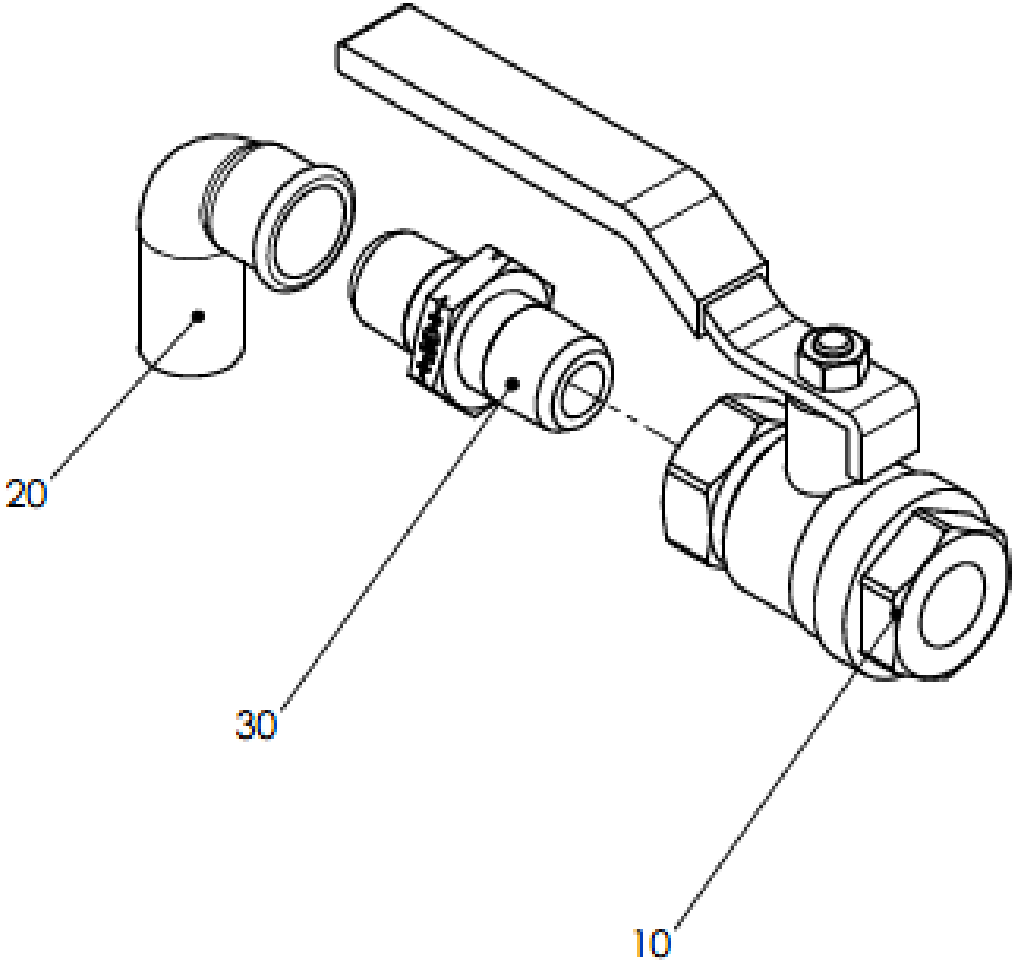

<b>ITEM</b>	<b>PART NO.</b>	<b>DESCRIPTION</b>	<b>QTY</b>
<b>TAG NO.</b>			
		<b>Drawing CC0813 Condensate drain</b>	
10	17811-CC0975	Ball valve	1
20	17811-CC0976	Angle	1
30	17811-CC0977	Double nipple	1

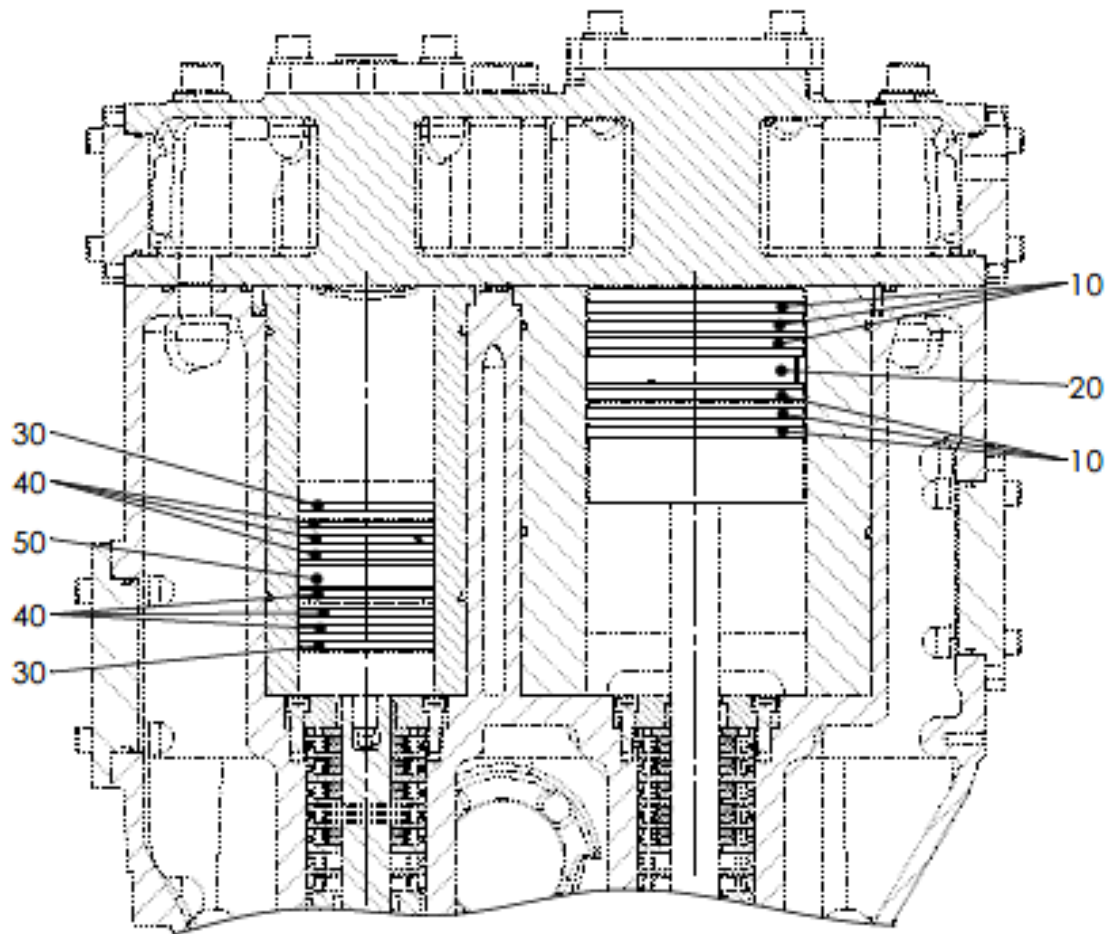

<b>ITEM</b>	<b>PART NO.</b>	<b>DESCRIPTION</b>	<b>QTY</b>
<b>TAG NO.</b>			
		<b>Drawing CC0814 Piston and guide rings assembly</b>	
10	17811-CC0978	Piston ring	6
20	17811-CC0979	Guide ring	1
30	17811-CC0980	Piston ring	2
40	17811-CC0981	Piston ring	6
50	17811-CC0982	Guide ring	1

Drawing CC0815 Working valves (assembly)

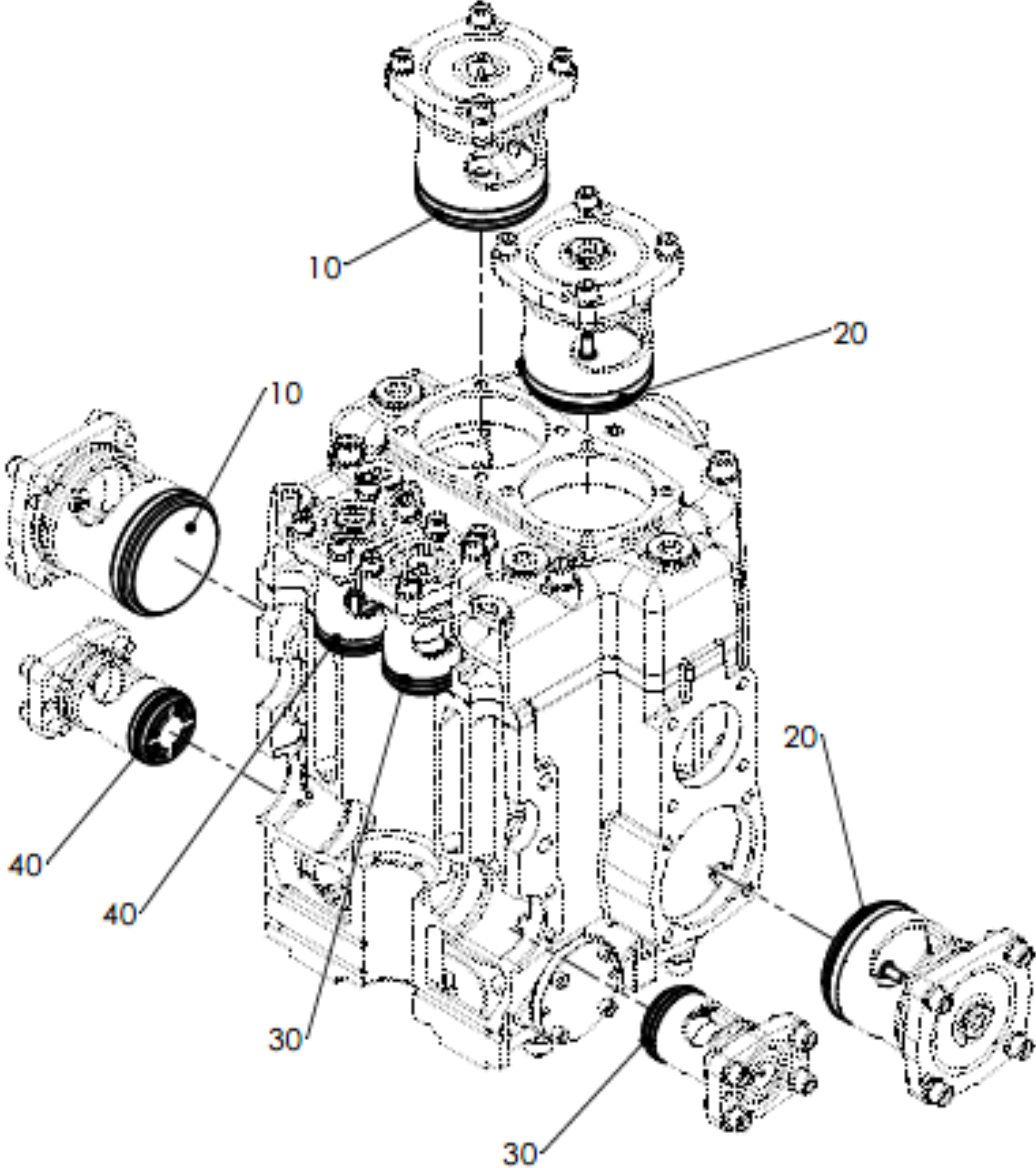

<b>ITEM</b>	<b>PART NO.</b>	<b>DESCRIPTION</b>	<b>QTY</b>
<b>TAG NO.</b>			
		<b>Drawing CC0815 Working valves (assembly)</b>	
10	17811-CC0983	Suction valve	2
20	17811-CC0984	Delivery valve	2
30	17811-CC0985	Suction valve	2
40	17811-CC0986	Delivery valve	2

# Drawing CC0816 Piston assembly

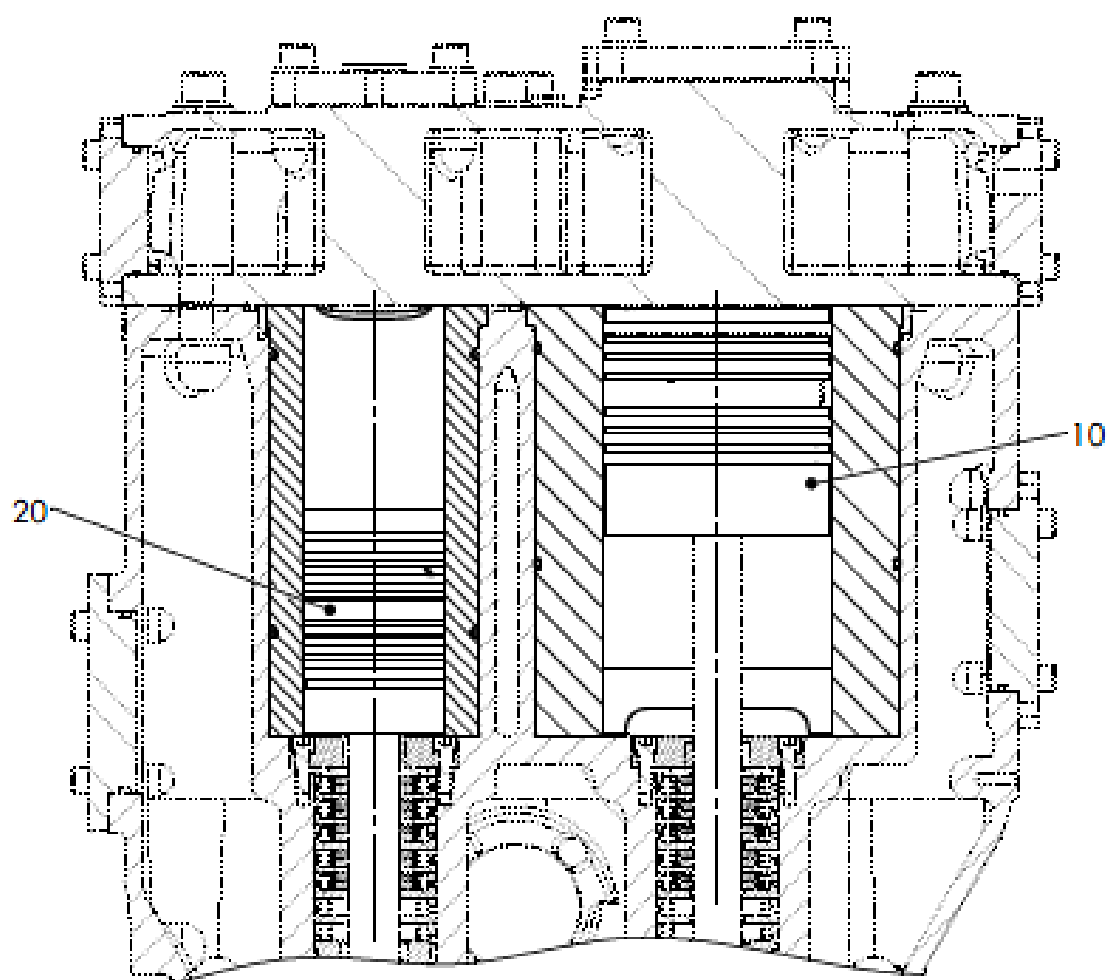

<b>ITEM</b>	<b>PART NO.</b>	<b>DESCRIPTION</b>	<b>QTY</b>
<b>TAG NO.</b>			
		<b>Drawing CC0816 Piston assembly</b>	
10	17811-CC0987	Piston	1
20	17811-CC0988	Piston	1

# Drawing CC0817 Piston

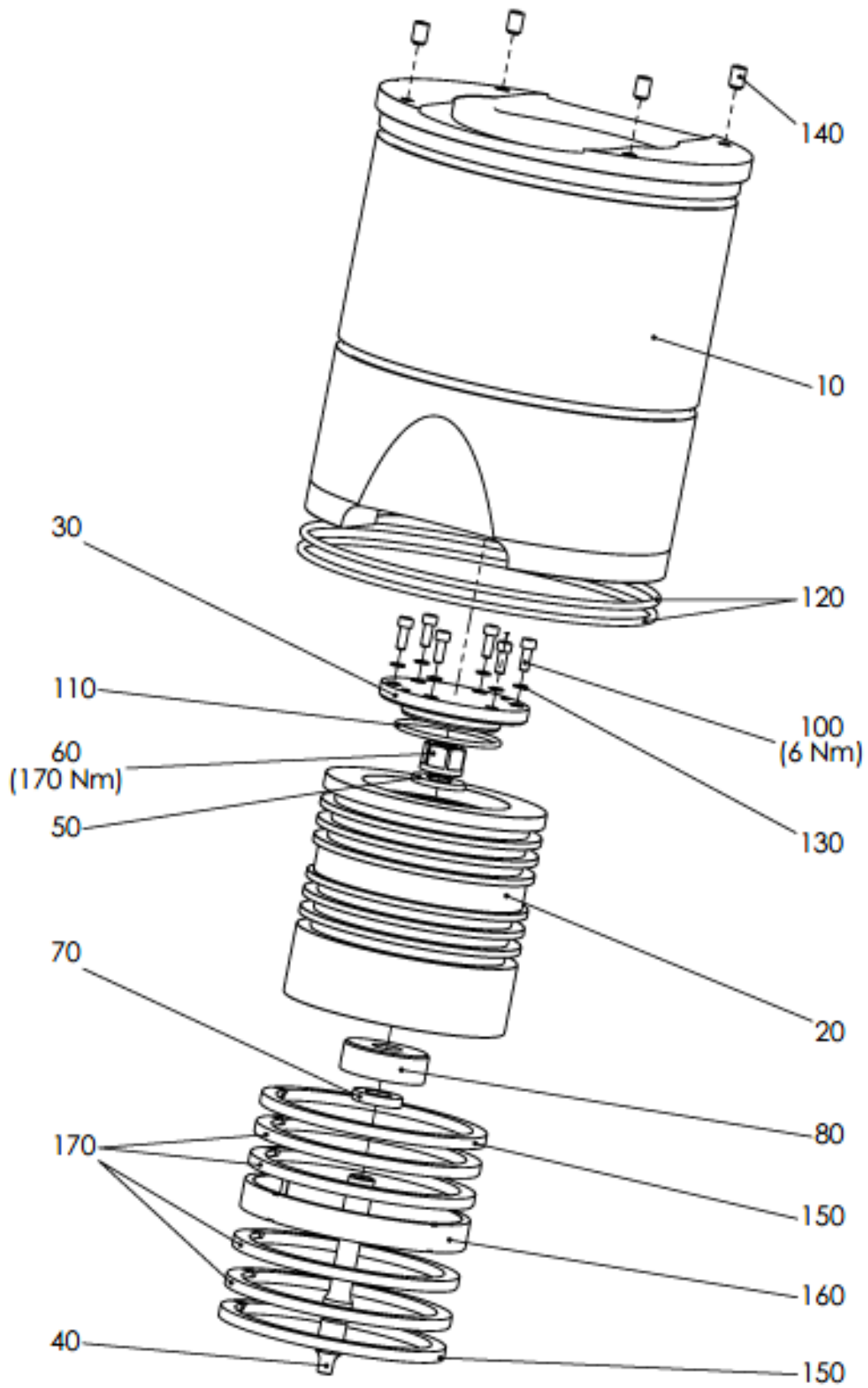

<b>ITEM</b>	<b>PART NO.</b>	<b>DESCRIPTION</b>	<b>QTY</b>
<b>TAG NO.</b>			
		<b>Drawing CC0817 Piston</b>	
10	17811-CC0989	Cylinder liner	1
20	17811-CC0990	Piston	1
30	17811-CC0991	Piston cover	1
40	17811-CC0992	Screw	1
50	17811-CC0993	Pressure washer	1
60	17811-CC0994	Nut	1
70	17811-CC0995	Pressure washer	1
80	17811-CC0996	Pressure washer	1
100	17811-CC0997	Hexagon socket h.c. screw	6
110	17811-CC0998	O-ring	1
120	17811-CC0999	O-ring	2
130	17811-CC1000	Lock plate	6
140	17811-CC1001	Set screw	4
150	17811-CC1002	see 1.assy Pos.20.1 resp. 20	2
160	17811-CC1003	see 1.assy Pos.20.2 resp. 20	1
170	17811-CC1004	see 1.assy Pos.20.3 resp. 20	4

# Drawing CC0818 Piston

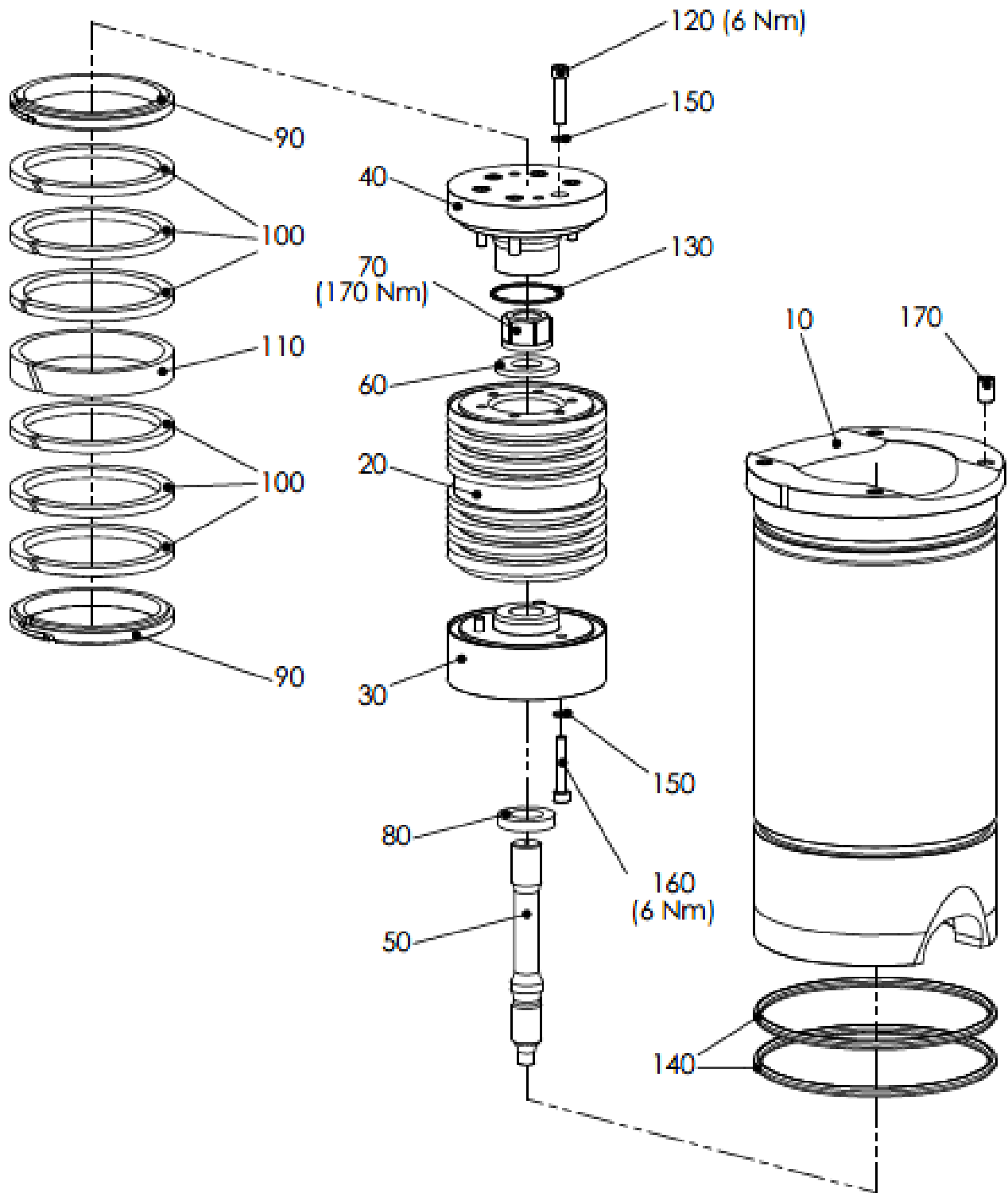

<b>ITEM</b>	<b>PART NO.</b>	<b>DESCRIPTION</b>	<b>QTY</b>
<b>TAG NO.</b>			
		<b>Drawing CC0818 Piston</b>	
10	17811-CC1005	Cylinder liner	1
20	17811-CC1006	Piston top	1
30	17811-CC1007	Piston lower part	1
40	17811-CC1008	Piston cover	1
50	17811-CC1009	Screw	1
60	17811-CC1010	Pressure washer	1
70	17811-CC1011	Nut	1
80	17811-CC1012	Pressure washer	1
90	17811-CC1013	see 1.assy Pos.20.1 resp. 20	2
100	17811-CC1014	see 1.assy Pos.20.3 resp. 20	6
110	17811-CC1015	see 1.assy Pos.20.2 resp. 20	1
120	17811-CC1016	Hexagon socket h.c. screw	6
130	17811-CC1017	O-ring	1
140	17811-CC1018	O-ring	2
150	17811-CC1019	Lock plate	9
160	17811-CC1020	Hexagon socket h.c. screw	3
170	17811-CC1021	Set screw	4

# Drawing CC0819 Gland gas

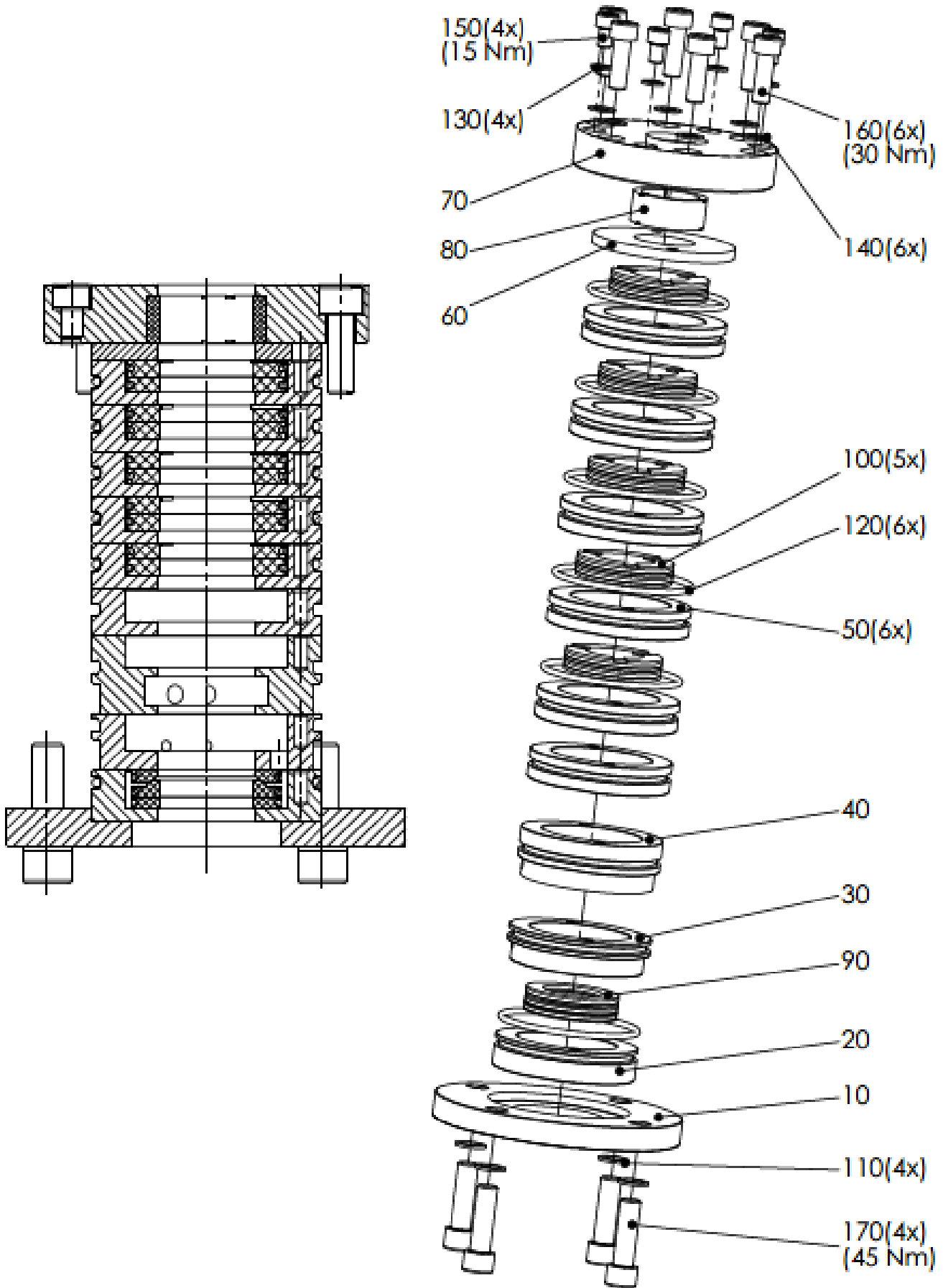

<b>ITEM</b>	<b>PART NO.</b>	<b>DESCRIPTION</b>	<b>QTY</b>
<b>TAG NO.</b>			
		<b>Drawing CC0819 Gland gas</b>	
10	17811-CC1022	Gland cover	1
20	17811-CC1023	Gland chamber	1
30	17811-CC1024	Gland chamber	1
40	17811-CC1025	Leak gas ring	1
50	17811-CC1026	Gland chamber	6
60	17811-CC1027	Washer	1
70	17811-CC1028	Gland cover	1
80	17811-CC1029	Guide ring	1
90	17811-CC1030	Segmental Ring	1
100	17811-CC1031	Segmental Ring	5
110	17811-CC1032	Lock plate	4
120	17811-CC1033	O-ring	6
130	17811-CC1034	Lock plate	4
140	17811-CC1035	Lock plate	6
150	17811-CC1036	Hexagon socket h.c. screw	4
160	17811-CC1037	Hexagon socket h.c. screw	6
170	17811-CC1038	Hexagon socket h.c. screw	4

# Drawing CC0820 Valve control assembly

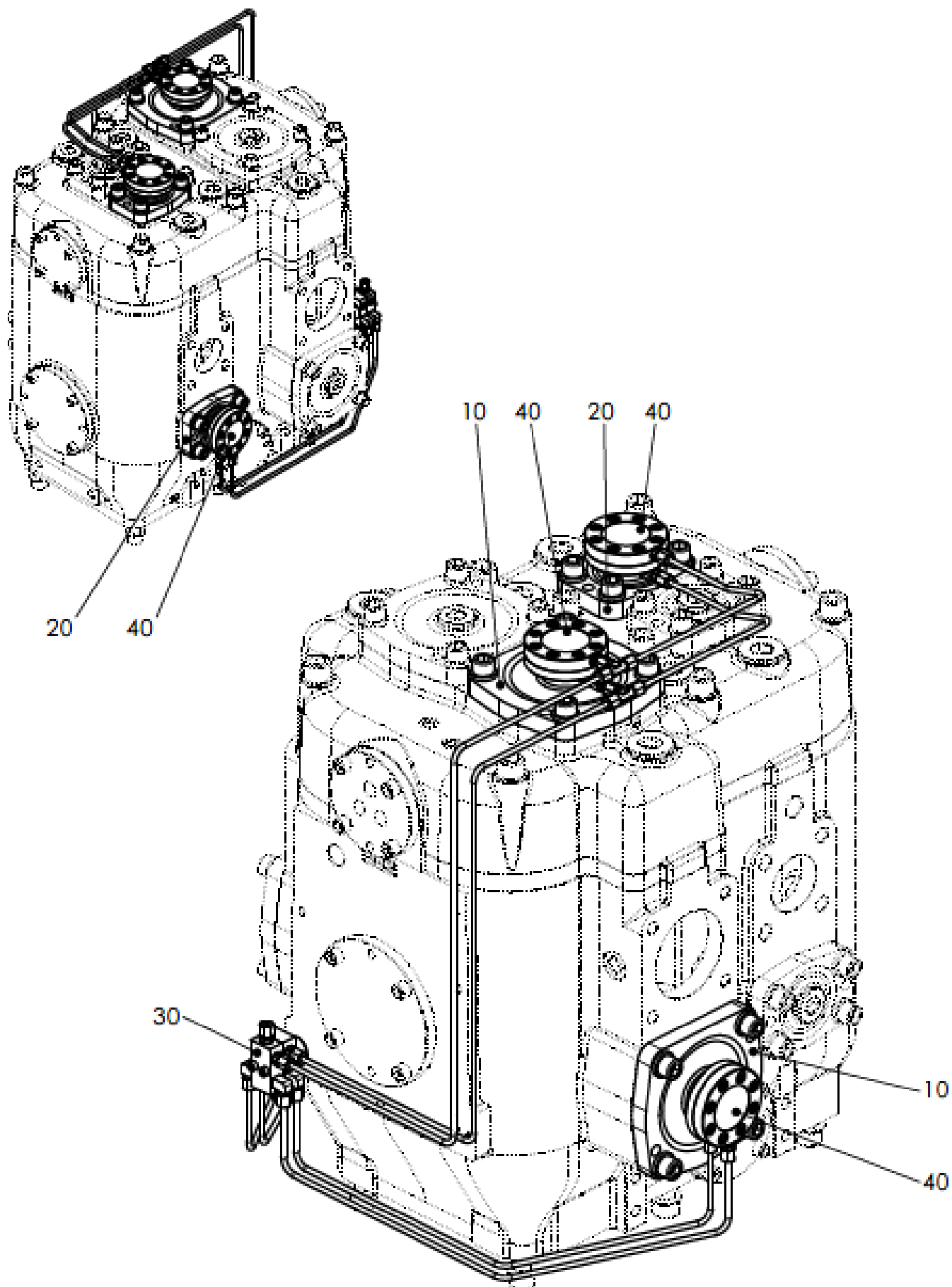

<b>ITEM</b>	<b>PART NO.</b>	<b>DESCRIPTION</b>	<b>QTY</b>
<b>TAG NO.</b>			
		<b>Drawing CC0820 Valve control assembly</b>	
10	17811-CC1039	Valve control	2
20	17811-CC1040	Valve control	2
30	17811-CC1041	Piping - valve control	1
40	17811-CC1042	Control unit	4
50	17811-CC1043	Plate	1
60	17811-CC1044	Plate	1

# Drawing CC0821 Valve control

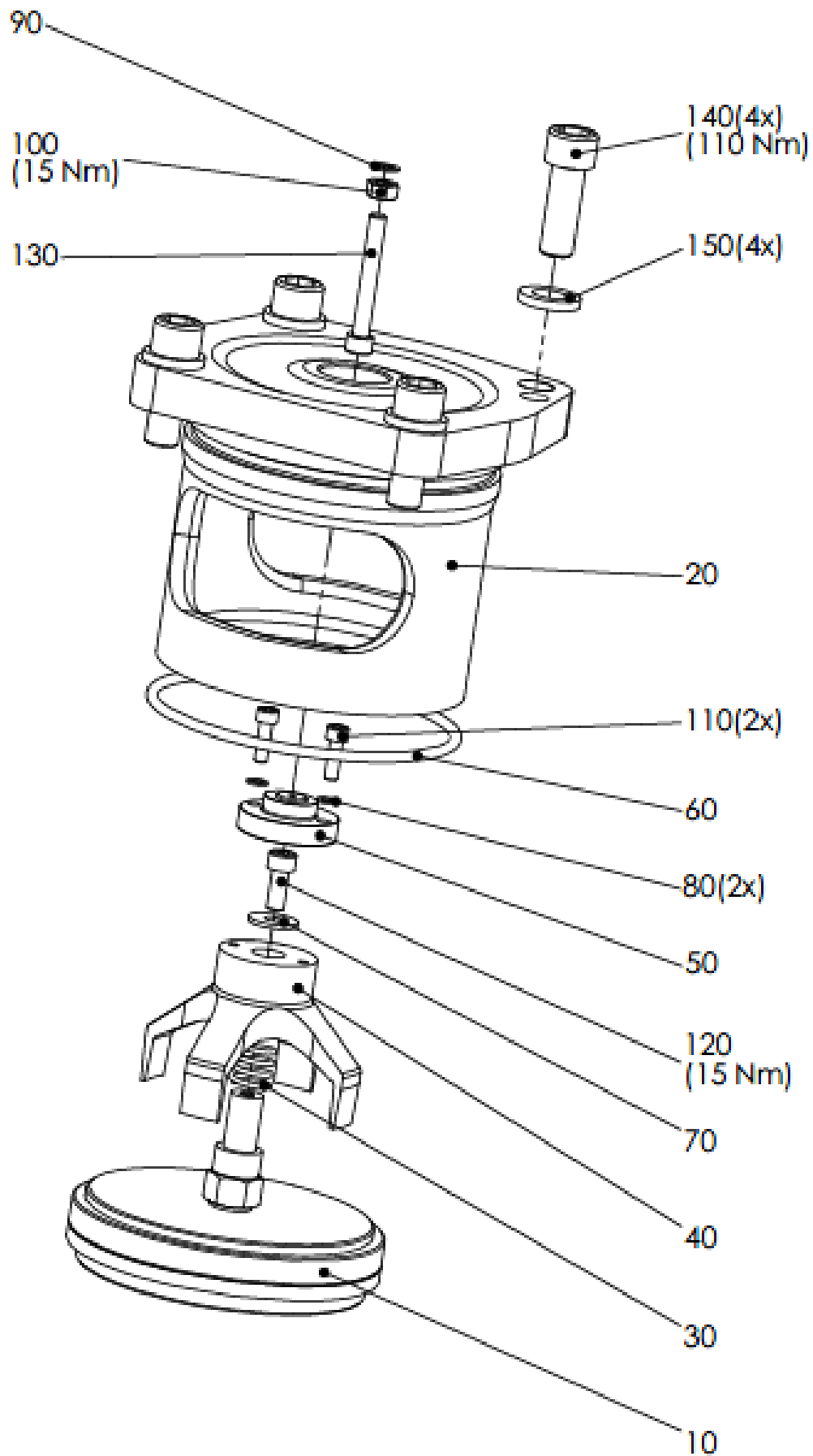

<b>ITEM</b>	<b>PART NO.</b>	<b>DESCRIPTION</b>	<b>QTY</b>
<b>TAG NO.</b>			
		<b>Drawing CC0821 Valve control</b>	
10	17811-CC1045	see 1.assy Pos 30.1 resp. 30	1
20	17811-CC1046	Valve lantern	1
30	17811-CC1047	Pressure spring	1
40	17811-CC1048	Unloader fork	1
50	17811-CC1049	Pressure piece	1
60	17811-CC1050	O-ring	1
70	17811-CC1051	Washer	1
80	17811-CC1052	Lock plate	2
90	17811-CC1053	Lock plate	1
100	17811-CC1054	Hexagon nut	1
110	17811-CC1055	Hexagon socket h.c. screw	2
120	17811-CC1056	Hexagon socket h.c. screw	1
130	17811-CC1057	Hexagon socket h.c. screw	1
140	17811-CC1058	Hexagon socket h.c. screw	4
150	17811-CC1059	Lock plate	4

# Drawing CC0822 Valve control

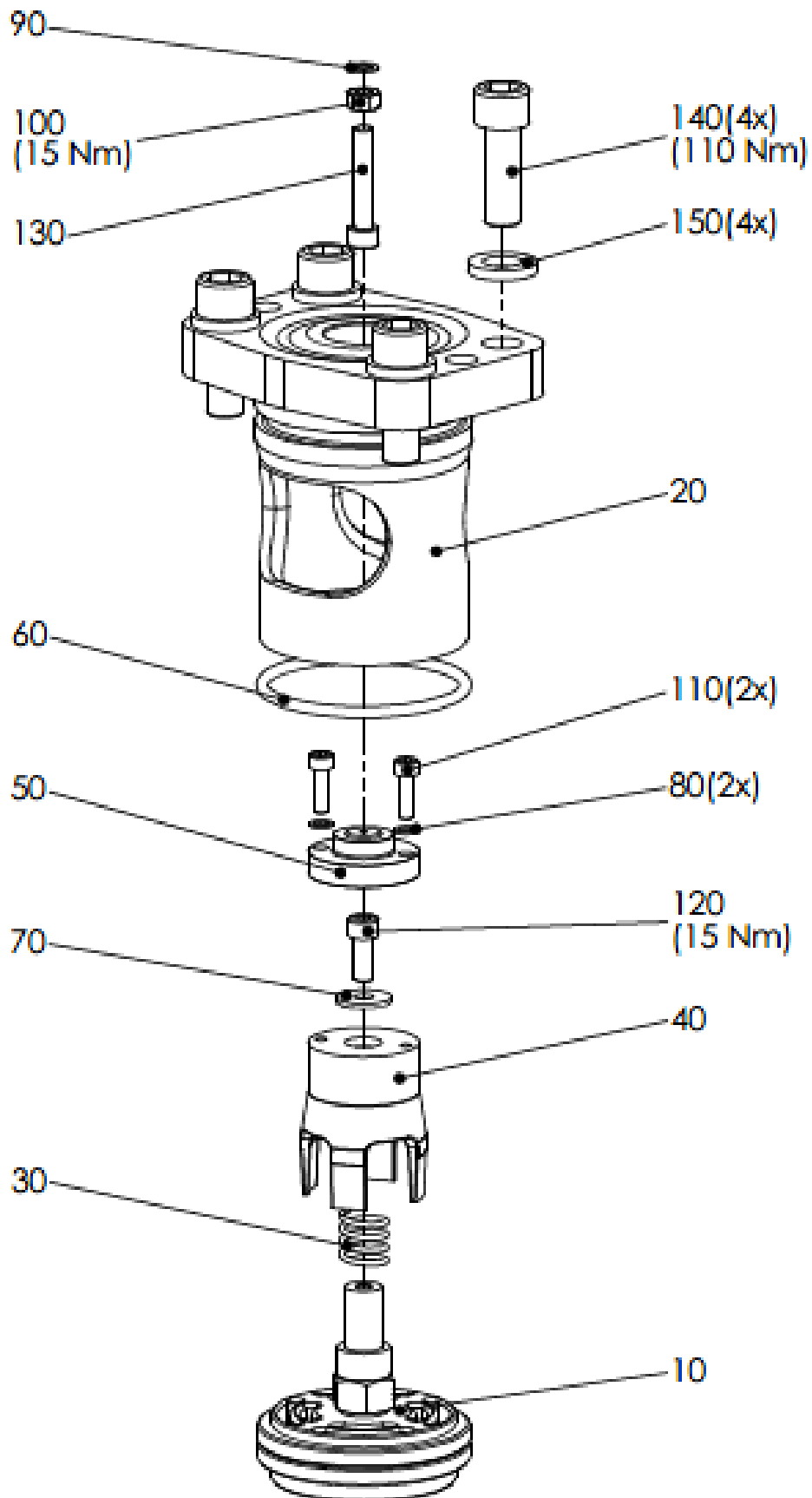

<b>ITEM</b>	<b>PART NO.</b>	<b>DESCRIPTION</b>	<b>QTY</b>
<b>TAG NO.</b>			
		<b>Drawing CC0822 Valve control</b>	
10	17811-CC1060	see 1.assy Pos.30.3 resp. 30	1
20	17811-CC1061	Valve lantern	1
30	17811-CC1062	Pressure spring	1
40	17811-CC1063	Unloader fork	1
50	17811-CC1064	Pressure piece	1
60	17811-CC1065	O-ring	1
70	17811-CC1066	Washer	1
80	17811-CC1067	Lock plate	2
90	17811-CC1068	Lock plate	1
100	17811-CC1069	Hexagon nut	1
110	17811-CC1070	Hexagon socket h.c. screw	2
120	17811-CC1071	Hexagon socket h.c. screw	1
130	17811-CC1072	Hexagon socket h.c. screw	1
140	17811-CC1073	Hexagon socket h.c. screw	4
150	17811-CC1074	Lock plate	4

Drawing CC0823 Piping valve control

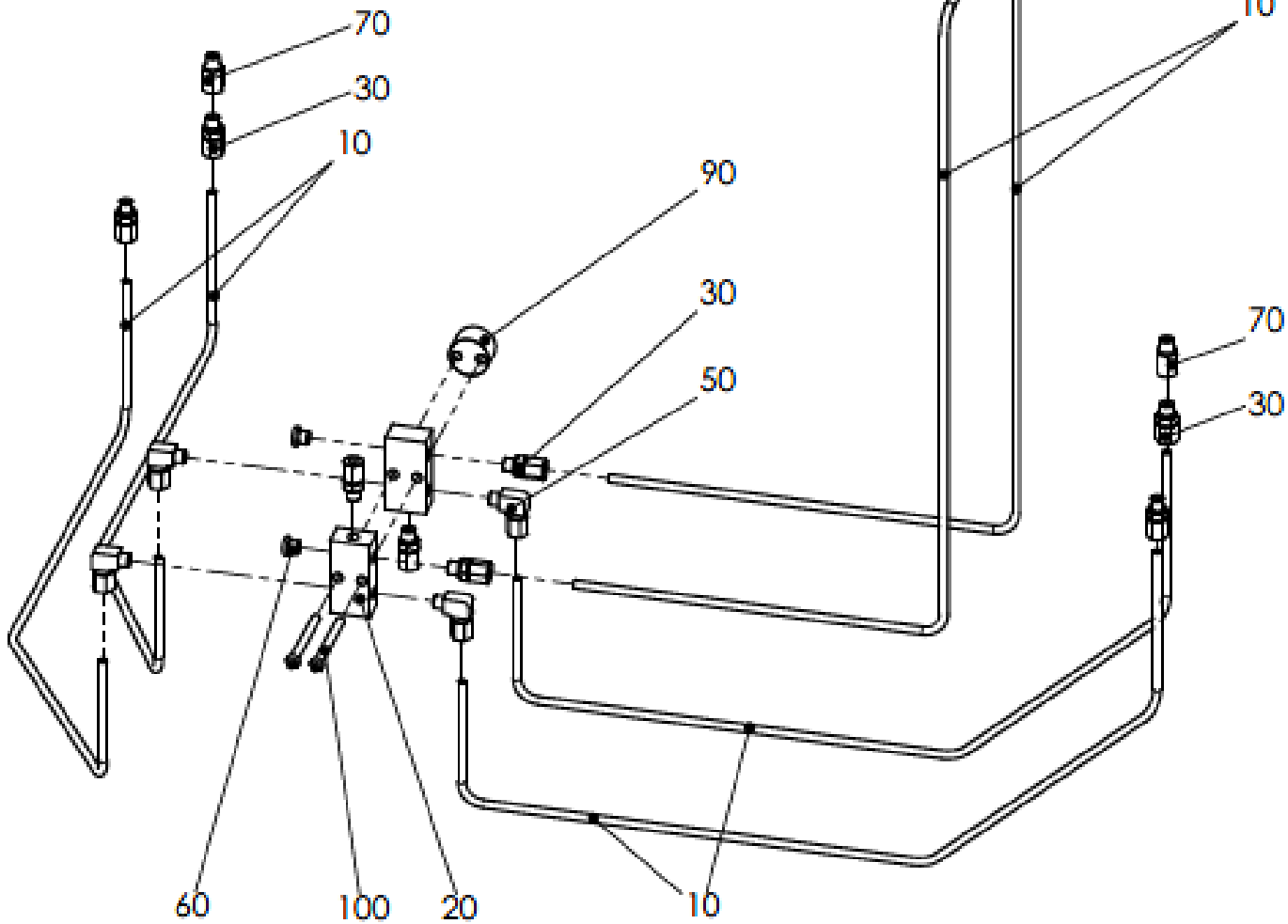
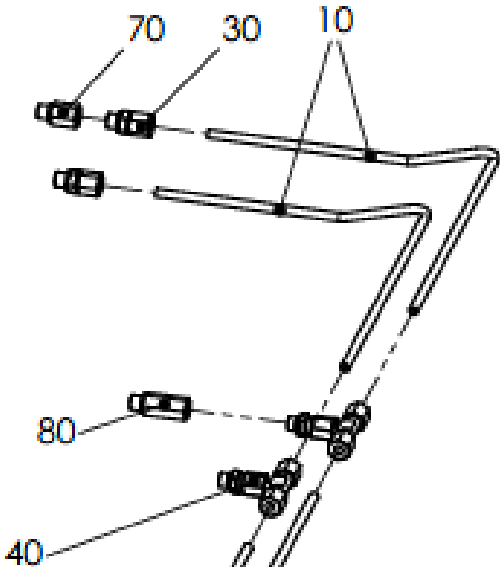
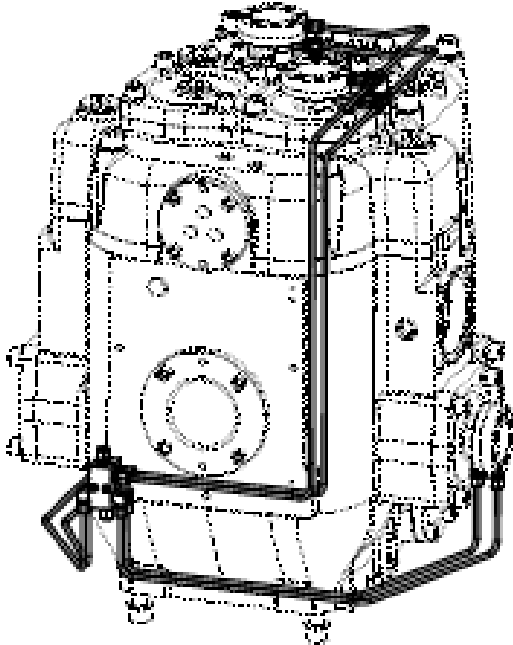

<b>ITEM</b>	<b>PART NO.</b>	<b>DESCRIPTION</b>	<b>QTY</b>
<b>TAG NO.</b>			
		<b>Drawing CC0823 Piping valve control</b>	
10	17811-CC1075	Tube	5,9
20	17811-CC1076	Distributor	2
30	17811-CC1077	Threaded joint	10
40	17811-CC1078	T-Screw connection	2
50	17811-CC1079	Angular threaded joint	4
60	17811-CC1080	Screw plug	2
70	17811-CC1081	Screwing socket	3
80	17811-CC1082	Screwing socket	1
90	17811-CC1083	Adaptor	1
100	17811-CC1084	Hexagon socket h.c. screw	2

Drawing CC0824 Control unit

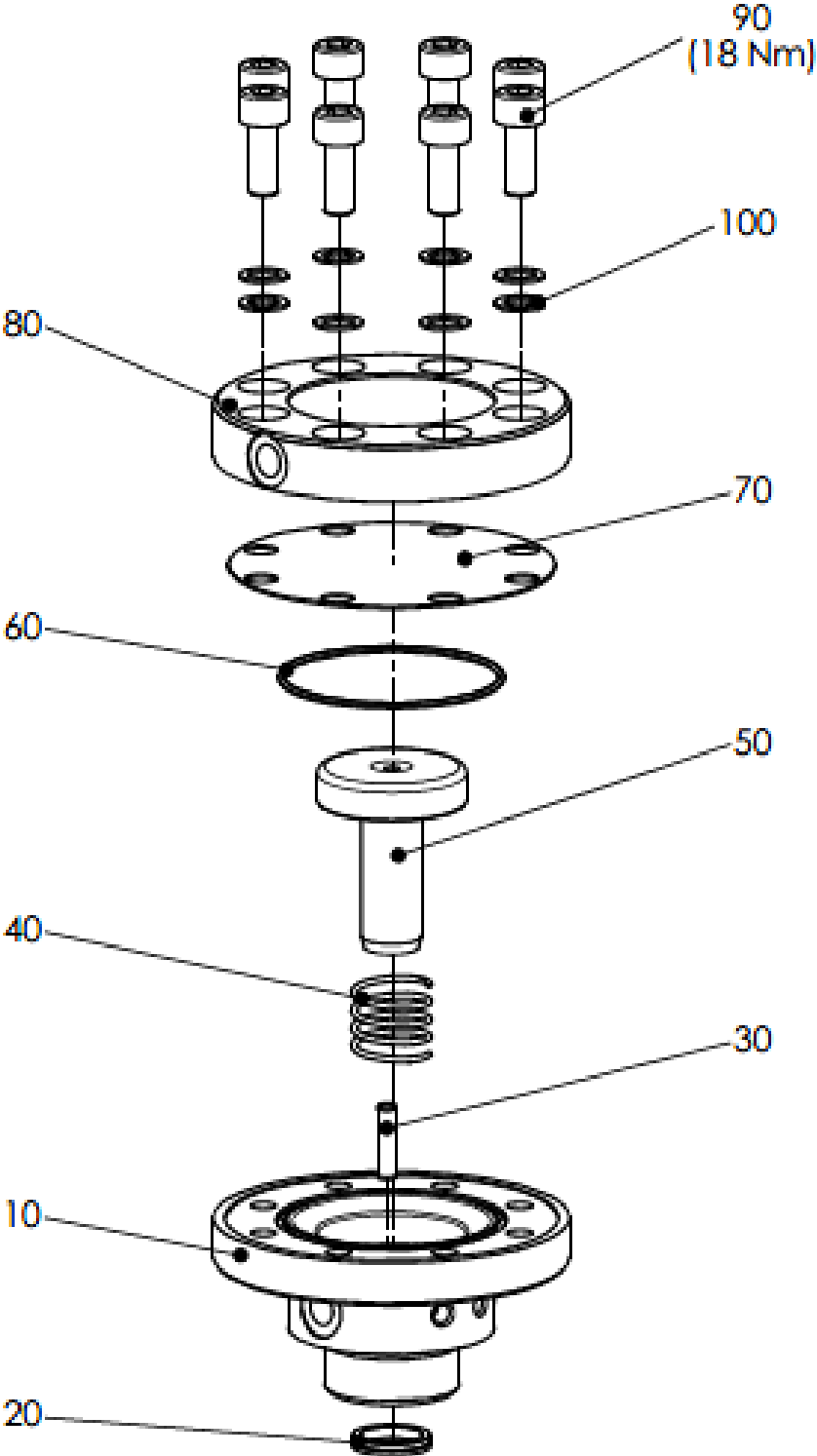

<b>ITEM</b>	<b>PART NO.</b>	<b>DESCRIPTION</b>	<b>QTY</b>
<b>TAG NO.</b>			
		<b>Drawing CC0824 Control unit</b>	
10	17811-CC1085	Cylinder	1
20	17811-CC1086	Slotted ring	1
30	17811-CC1087	Straight pin	1
40	17811-CC1088	Pressure spring	1
50	17811-CC1089	Piston	1
60	17811-CC1090	O-ring	1
70	17811-CC1091	Diaphragm	1
80	17811-CC1092	Cover	1
90	17811-CC1093	Hexagon socket h.c. screw	8
100	17811-CC1094	Lock plate	8

# Drawing CC0825 Leak gas - Gland

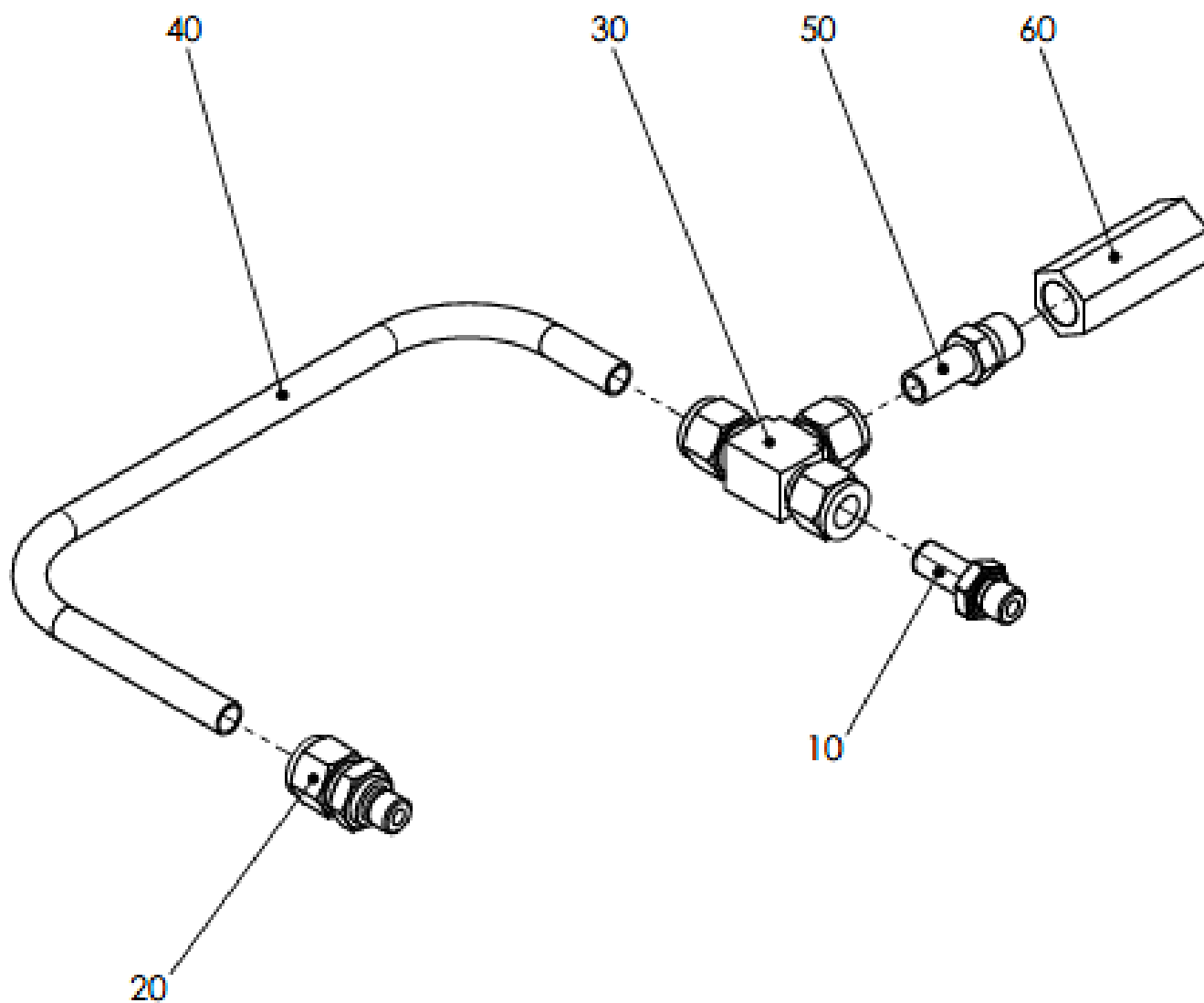

<b>ITEM</b>	<b>PART NO.</b>	<b>DESCRIPTION</b>	<b>QTY</b>
<b>TAG NO.</b>			
		<b>Drawing CC0825 Leak gas - Gland</b>	
10	17811-CC1095	Tube adapter	1
20	17811-CC1096	Straight connection	1
30	17811-CC1097	T-threaded joint	1
40	17811-CC1098	Pipeline	1
50	17811-CC1099	Tube adapter	1
60	17811-CC1100	Non-return valve	1

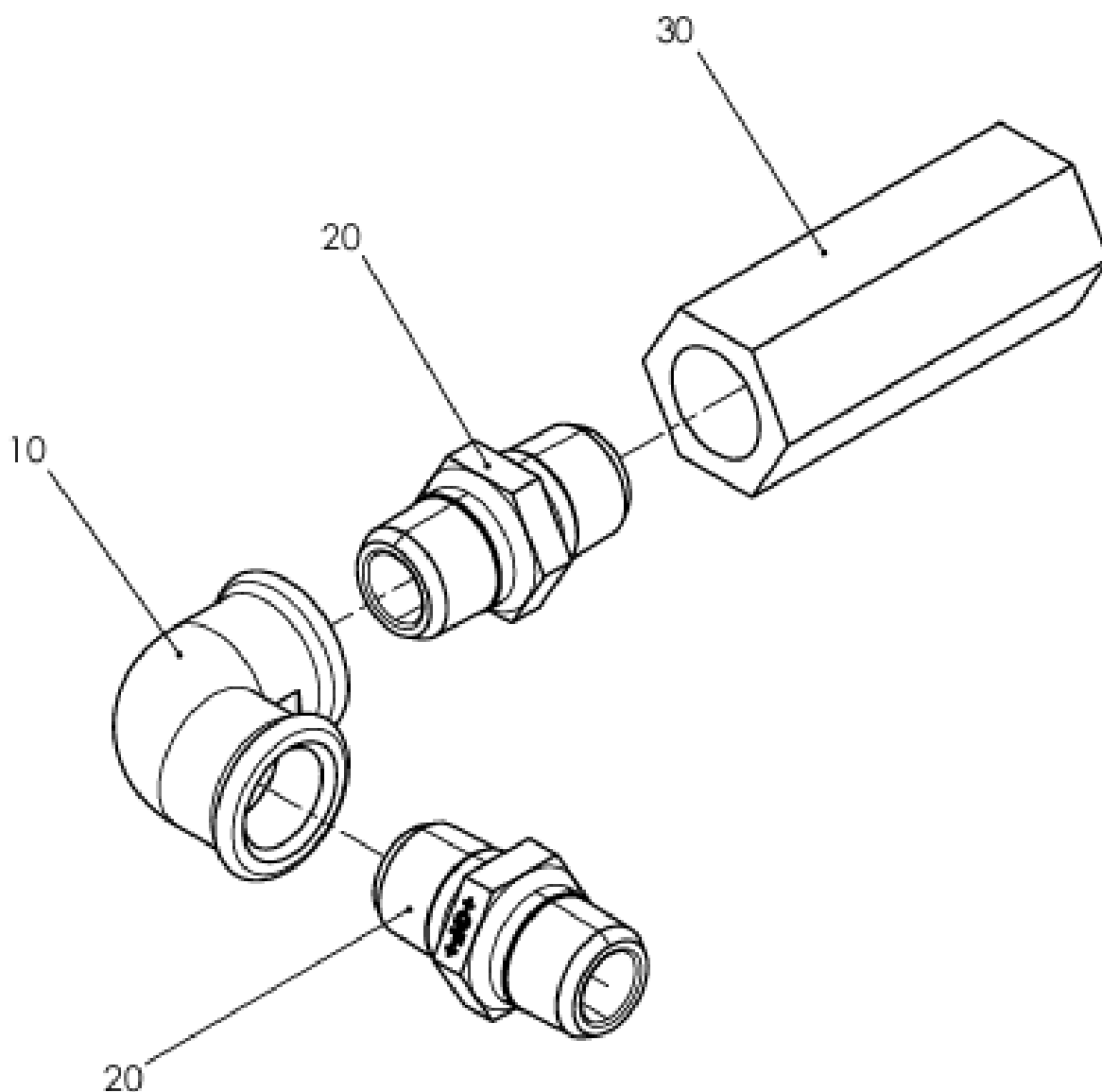

<b>ITEM</b>	<b>PART NO.</b>	<b>DESCRIPTION</b>	<b>QTY</b>
<b>TAG NO.</b>			
		<b>Drawing CC0826 Leak gas - Latern</b>	
10	17811-CC1101	Angle	1
20	17811-CC1102	Double nipple	2
30	17811-CC1103	Non-return valve	1

Drawing CC0827 Without purging gas

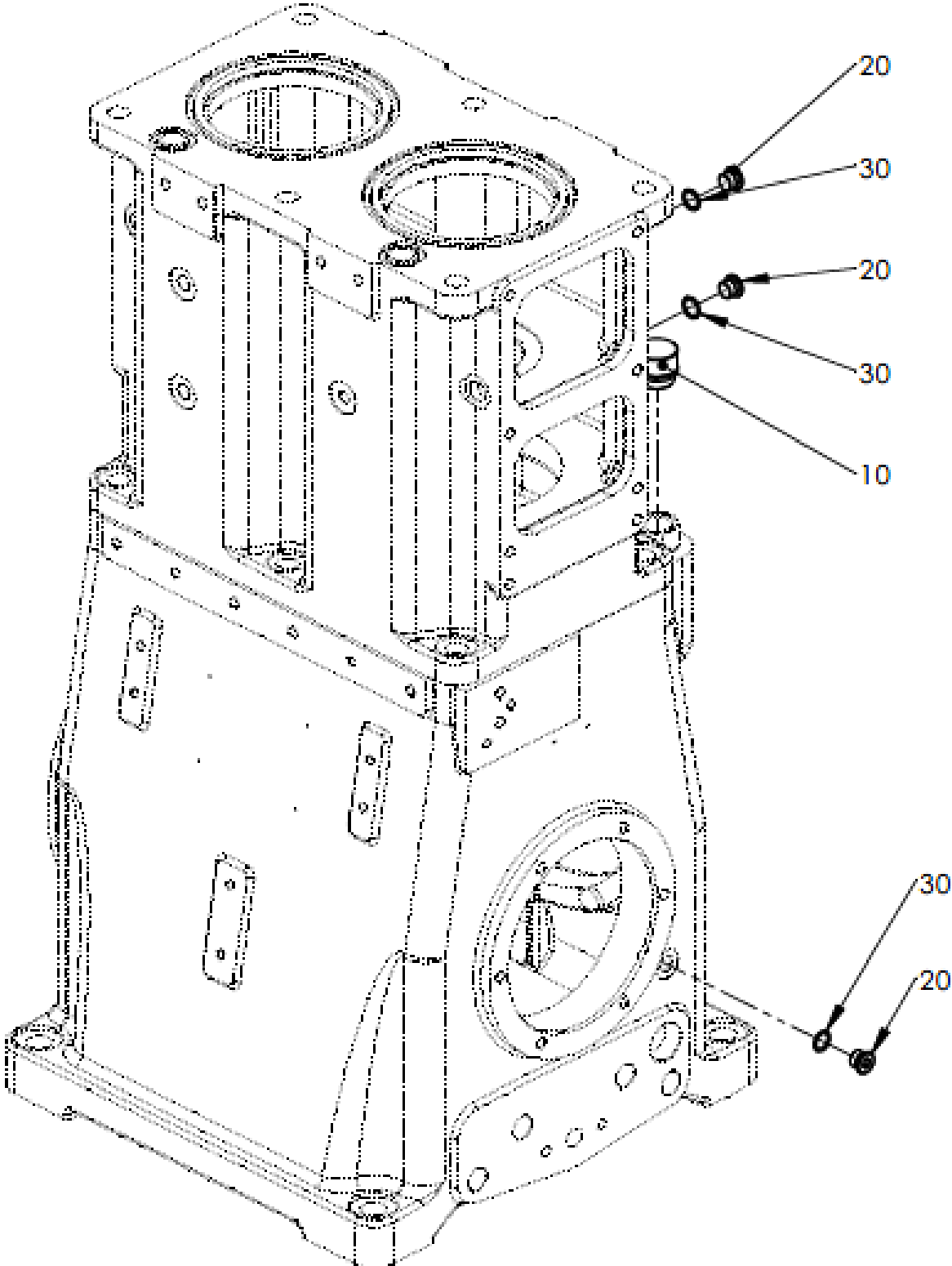

<b>ITEM</b>	<b>PART NO.</b>	<b>DESCRIPTION</b>	<b>QTY</b>
<b>TAG NO.</b>			
		<b>Drawing CC0827 Without purging gas</b>	
10	17811-CC1104	Vent screw	1
20	17811-CC1105	Screw plug	3
30	17811-CC1106	Sealing ring	3

# Drawing CC0828 Cooling water connection

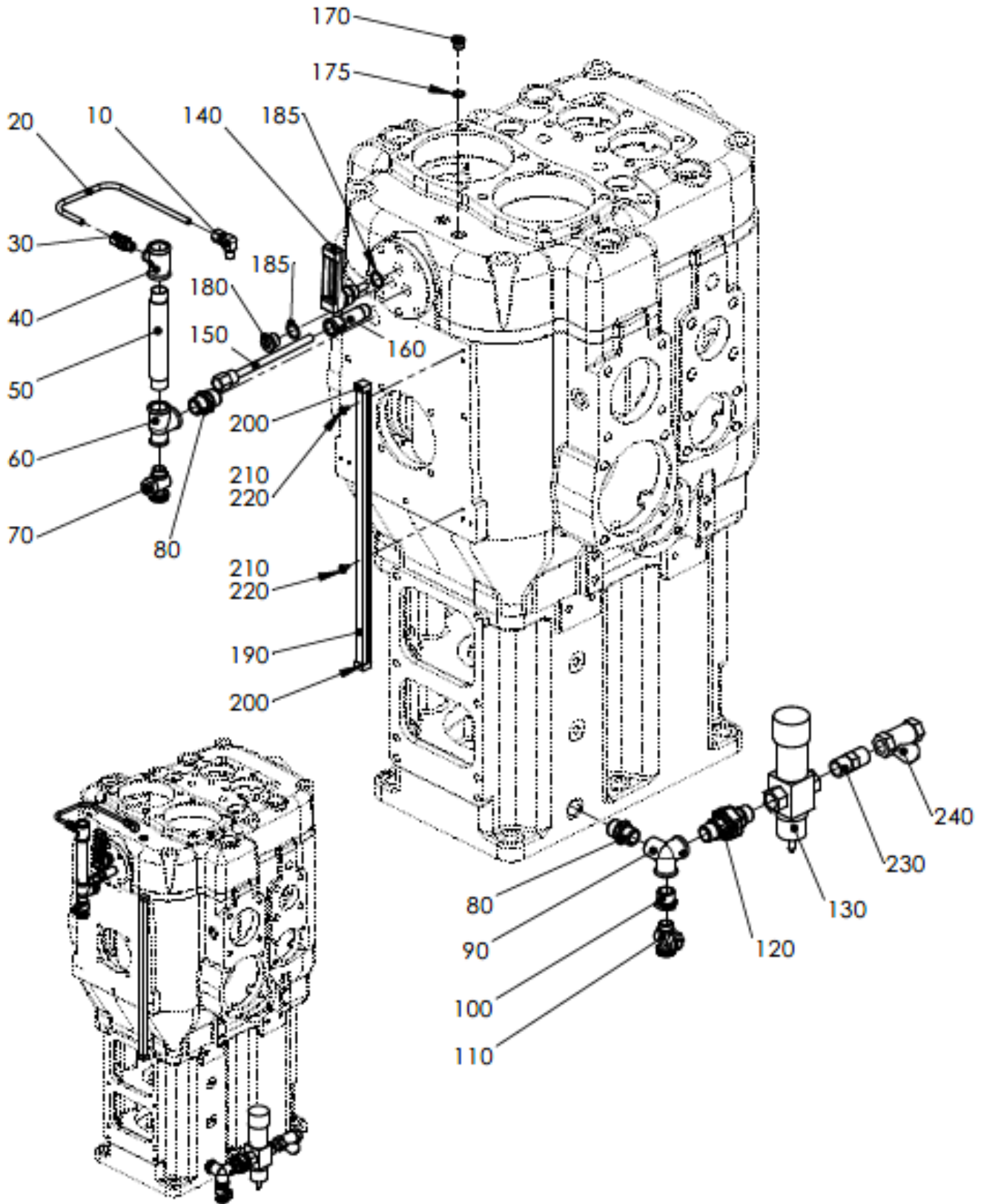

<b>ITEM</b>	<b>PART NO.</b>	<b>DESCRIPTION</b>	<b>QTY</b>
<b>TAG NO.</b>			
		<b>Drawing CC0828 Cooling water connection</b>	
10	17811-CC1107	Angular threaded joint	1
20	17811-CC1108	Pipeline	1
30	17811-CC1109	Threaded joint	1
40	17811-CC1110	T-Piece	1
50	17811-CC1111	Nipple	1
60	17811-CC1112	T-Piece	1
70	17811-CC1113	Drain valve	1
80	17811-CC1114	Double nipple	2
90	17811-CC1115	Elbow distributor	1
100	17811-CC1116	Reduction nipple	1
110	17811-CC1117	Drain valve	1
120	17811-CC1118	Threaded joint	1
130	17811-CC1119	Thermostatic valve	1
140	17811-CC1120	Thermometer	1
150	17811-CC1121	Protective tube	1
160	17811-CC1122	Extension tube	1
170	17811-CC1123	Screw plug	1
170,1	17811-CC1124	Sealing ring	1
180	17811-CC1125	Plug	1
185	17811-CC1126	Sealing ring	2
190	17811-CC1127	Cable channel	0,5
200	17811-CC1128	Guard ring	2
210	17811-CC1129	Washer	2
220	17811-CC1130	Hexagon socket h.c. screw	2
230	17811-CC1131	Nipple	1
240	17811-CC1132	Strainer	1

<b>ITEM</b>	<b>PART NO.</b>	<b>DESCRIPTION</b>	<b>QTY</b>
<b>TAG NO.</b>			
	17811-C1133	Suction valve 1st stage	2
	17811-C1134	Delivery valve 1st stage	2
	17811-C1135	Suction valve 2nd stage	2
	17811-C1136	Drawing CC0830 Delivery valve 2nd stage	2

<b>ITEM</b>	<b>PART NO.</b>	<b>DESCRIPTION</b>	<b>QTY</b>
<b>TAG NO.</b>			
	17811-C1137	seal kit oil change	
	17811-C1138	O-ring	1
	17811-C1139	Sealing ring	1
	17811-C1140	O-ring	1
	17811-C1141	Oil 10 litre	1
	17811-C1142	Oil 1 litre	4
	17811-C1143	Filter element	1

<b>ITEM</b>	<b>PART NO.</b>	<b>DESCRIPTION</b>	<b>QTY</b>
<b>TAG NO.</b>			
	17811-C0802	oil heater	1
	17811-C0802A	oil heater thermostat	1
20-AEC-1002-1	17811-C0001	Inter cooler	1
20-AEC-1002-2	17811-C0002	After cooler	1

<b>ITEM</b>	<b>PART NO.</b>	<b>DESCRIPTION</b>	<b>QTY</b>
<b>TAG NO.</b>			
20-C-1002-M	17811-M0000	Main motor	1
	17811-M0002A	Motor bearing drive end	1
	17811-M0002B	Motor bearing non- drive end	1
	17811-M0002C	cooling fan	
	17811-M0002D	terminal block	

<b>ITEM TAG NO.</b>	<b>PART NO.</b>	<b>DESCRIPTION</b>	<b>QTY</b>
VT-10151	17811-S0600	Vibration Transmitter	1
FT-10151	17811-S0500	Flowmeter 2"	1
PIT-10153	17811-S0700	Pressure transmitter	5
PIT-10158			
PIT-10159			
PIT-10156			
PIT-10157			
PIT-10154	17811-S0701	Pressure transmitter	1
TIT-10151	17811-S0702	Temperature Transmitter	5
TIT-10152			
TIT-10153			
TIT-10154			
TIT-10155			
PDG-10151	17811-G0000	Differential pressure gauge	1
PG-10152	17811-G0001	Pressure Gauge	1
PG-10155	17811-G0002	Pressure Gauge	1
PG-10161	17811-G0003	Pressure Gauge	1
PG-10160	17811-G0004	Pressure Gauge	1
TG-10156	17811-G0005	Temperature Gauge	3
TG-10157			
TG-10158			
compressor inlet	17811-F0100	Y-strainer	2

<b>ITEM TAG NO.</b>	<b>PART NO.</b>	<b>DESCRIPTION</b>	<b>QTY</b>
TW-10151	17811-S0703	Thermowell	8
TW-10152			
TW-10153			
TW-10154			
TW-10155			
TW-10156			
TW-10157			
TW-10158			
TE-10151	17811-S0704	Temperature Assembly	5
TE-10152			
TE-10153			
TE-10154			
TE-10155			
inlet valve	17811-V0000	Hand Ball Valve 2" 150#	1
outlet valve	17811-V0001	Hand Ball Valve 2" 300#	1
cooling water inlet	17811-V0002	Hand Ball Valve 2" 150#	2
block valves instru	17811-V0003	Hand Ball Valve 1/2" 800#	2
block valves instru	17811-V0004	Hand Ball Valve 1/2" 800#	7
XV-10152	17811-V0005	Pneumatic Actuated Valve 2" 150#	1
cooler flow adjust	17811-V0006	Globe Valve 1 1/2" 150#	2
package outlet	17811-V0200	Check Valve	2
cooling water	17811-V0201	Check Valve 1 1/2"	1
PSV-10151	17811-V0300	Pressure Safety Valve	1
PSV-10152	17811-V0301	Pressure Safety Valve	1
PSV-10153	17811-V0302	Pressure Safety Valve	1
No tag	17811-V0500	5-way Manifold	1
No tag	17811-V0501	2-way Manifold, lockable	1

<b>ITEM</b>	<b>PART NO.</b>	<b>DESCRIPTION</b>	<b>QTY</b>
<b>TAG NO.</b>			
No tag	17811-V0502	2-way Manifold	9
XY-10151	17811-V0600	Solenoid Valve	<u>2</u>
XY-10152			
instrument air	17811-V0800	Pressure Reducing Valve	1
PV-10151	17811-V0801	Pressure Control Valve	1

<b>ITEM TAG NO.</b>	<b>PART NO.</b>	<b>DESCRIPTION</b>	<b>QTY</b>
		<b>UCP</b>	
2M14	17811-E0000	Panel Fan + Filter	1
2H19	17811-E0001	Power On Lamp	1
8A9	17811-E0002	HMI	1
25U12	17811-E0003	Hourmeter	1
25H4	17811-E0004	Operational Lamp (Green)	1
25H6	17811-E0005	Running Lamp (Green)	1
25H8	17811-E0006	Common Alarm Lamp (Amber)	1
25H10	17811-E0007	Common Trip Lamp (Red)	1
11S3	17811-E0008	Start Pushbutton (Green)	1
11S5	17811-E0009	Stop Pushbutton (Red)	1
11S7	17811-E0010	Accept Pushbutton (Black)	1
11S9	17811-E0011	Reset Pushbutton (Black)	1
11S11	17811-E0012	Lamp Test Pushbutton (Black)	1
3S6	17811-E0013	ESD Pushbutton	1
2S2	17811-E0014	Maintenance Switches	3
2S4			
2S6			
2F11	17811-E0015	Dual Pole Circuit Breaker, 230VAC, 2A	1
2F9	17811-E0016	Dual Pole Circuit Breaker, 230VAC, 6A	1
2F15	17811-E0017	Dual Pole Circuit Breaker, 110VAC, 10A	2
2F17			
2TH11	17811-E0018	Thermostats	2
2TH14			
2V15	17811-E0019	Power Supplies, 110VAC/24VDC, 20A	2
2v17			
2U13	17811-E0020	Panel Heater	1
5M2	17811-E0021	S7-400 Power Supply	2
5M11			
5M3	17811-E0022	S7-400 Central Processing Unit	2
5M12			
5M5	17811-E0023	CP 443-1 Communication Module	2
5M14			
5M18	17811-E0024	Ethernet Switch	1
58U5	17811-E0025	PID Controller	1
6M2	17811-E0026	ET200M Interface IM153-2HF	4
6M4			
7M1			
7M3			
6M7	17811-E0027	24 Digital Input Module	4
6M9			

<b>ITEM</b>	<b>PART NO.</b>	<b>DESCRIPTION</b>	<b>QTY</b>
<b>TAG NO.</b>			
7M7			
7M9			
6M10	17811-E0028	6 Analog Input Module	6
6M12			
6M14			
7M10			
7M12			
7M14			
6M15	17811-E0029	10 Digital Output Module	8
6M16			
6M18			
6M19			
7M15			
7M16			
7M18			
7M19			
9V4	17811-E0030	Diode Blocks	48
9V4.1			
24V4			
24V6			
25V4			
25V6			
25V8			
25V10			
25V12			
26V4			
26V6			
26V8			
26V10			
26V12			
27V4			
27V6			
27V8			
28V4			
28V6			
28V8			
28V10			
28V12			
30V4			
30V6			
30V10			
47V4			

<b>ITEM</b>	<b>PART NO.</b>	<b>DESCRIPTION</b>	<b>QTY</b>
<b>TAG NO.</b>			
47V6			
48V4			
48V6			
48V8			
48V10			
48V12			
49V4			
49V6			
49V8			
49V10			
49V12			
50V4			
50V6			
50V8			
51V4			
51V6			
51V8			
51V10			
51V12			
53V4			
53V6			
53V10			
28K4	17811-E0031	Interface Relays	17
28K6			
28K8			
28K10			
28K12			
30K4			
30K6			
30K10			
56K4			
56K6			
56K8			
56K10			
56K13			
56K15			
56K17			
57K12			
58K10			
57K8	17811-E0032	ESD Relays, Single Pole	2
57K10			
24K4	17811-E0033	ESD Relays, Dual Pole	3

<b>ITEM</b>	<b>PART NO.</b>	<b>DESCRIPTION</b>	<b>QTY</b>
<b>TAG NO.</b>			
24K6			
27K8			
9U4	17811-E0034	Loop Splitters	17
9U5			
9U6			
9U7			
9U8			
9U9			
9U10			
9U11			
9U12			
9U12.1			
9U13			
9U14			
9U15			
9U16			
9U17			
9U18			
9U19			
5F2	17811-E0035	Dual Pole Circuit Breaker, 24VDC, 6A	2
5F11			
2F15.1	17811-E0036	Single Pole Circuit Breaker, 24VDC, 20A	2
2F17.1			
2G15	17811-E0037	Quint Diode	1
2H10	17811-E0038	Panel Light	1
		<b>LCP</b>	
3H4	17811-E0039	Operational lamp (green)	1
3H6	17811-E0040	Running lamp (green)	1
3H8	17811-E0041	Common alarm lamp (amber)	1
3H10	17811-E0042	Common trip lamp (red)	1
2S4	17811-E0043	Start pushbutton (green)	1
2S6	17811-E0044	Stop pushbutton (red)	1
2S8	17811-E0045	Lamp test pushbutton (black)	1
2S10	17811-E0046	Selector switch (local/off/remote)	1
4S3	17811-E0047	ESD button	1

## **Spare parts list for emergency instrument air compressor**

# Compressor

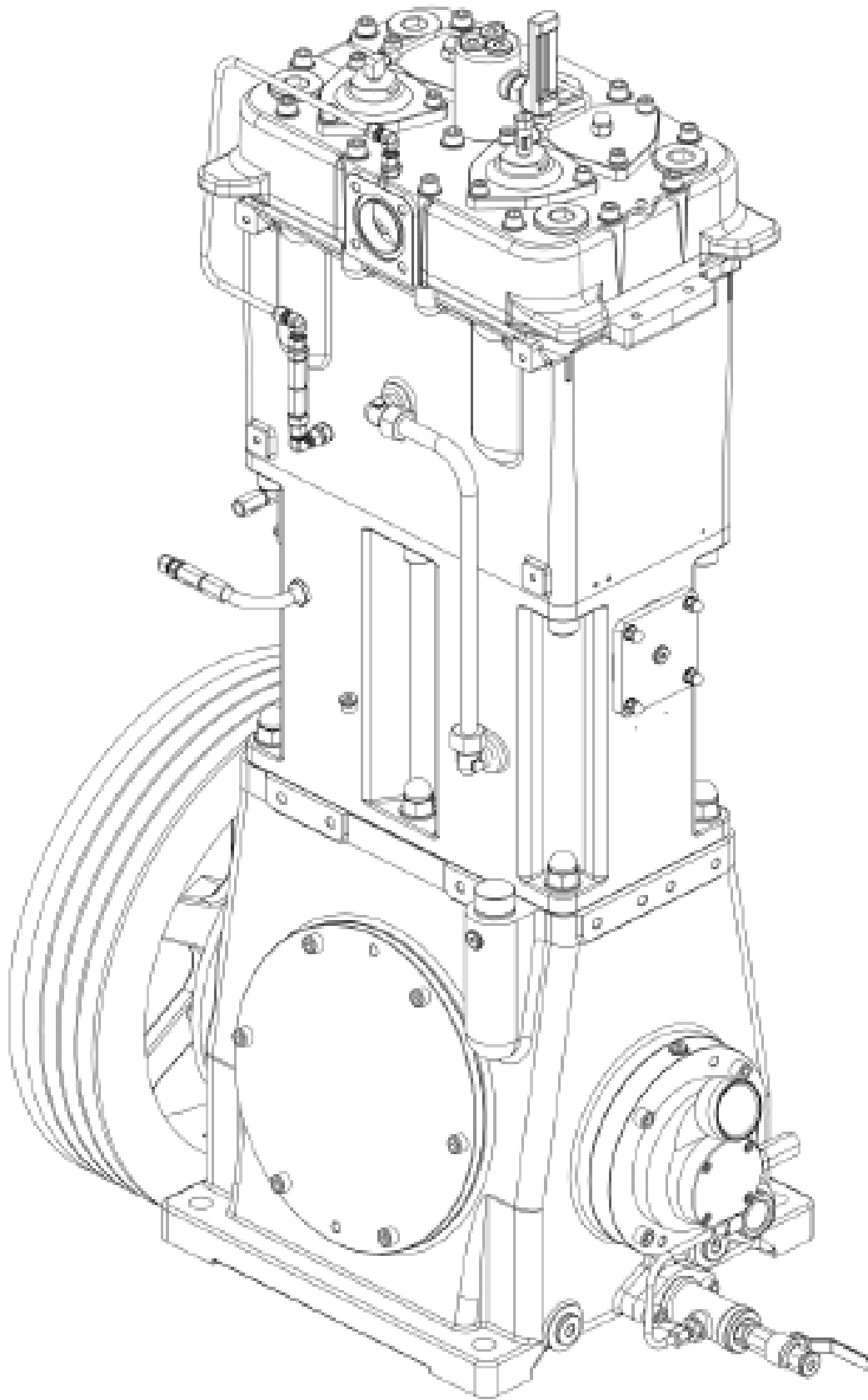

# Drawing CC15001 Compressor

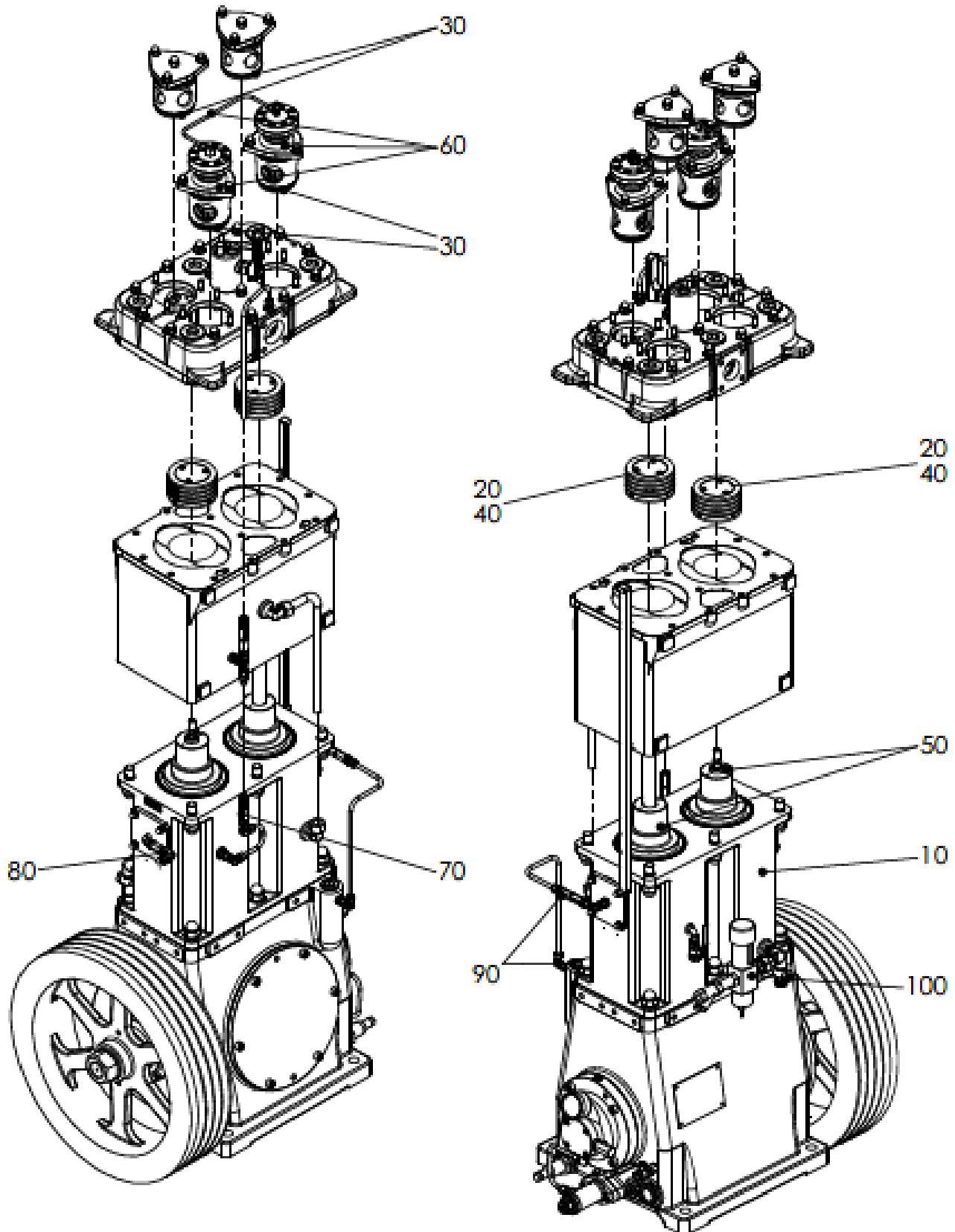

<b>ITEM</b>	<b>PART NO.</b>	<b>DESCRIPTION</b>	<b>QTY</b>
<b>TAG NO.</b>			
		<b>Drawing Compressor</b>	
	17811-CC1500	Compressor	1
		<b>Drawing CC15001 Compressor</b>	
10	17811-CC1501	Compressor-R	1
20	17811-CC1502	Piston and guide rings	1
30	17811-CC1503	Working valves (assembly)	1
40	17811-CC1504	Piston	2
50	17811-CC1505	Gland-gas	2
60	17811-CC1506	Valve control	1
70	17811-CC1507	Leak gas - gland	1
80	17811-CC1508	Leak gas - lantern	1
90	17811-CC1509	Without purging gas	1
100	17811-CC1510	Cooling water connection	1

# Drawing CC15002 Compressor

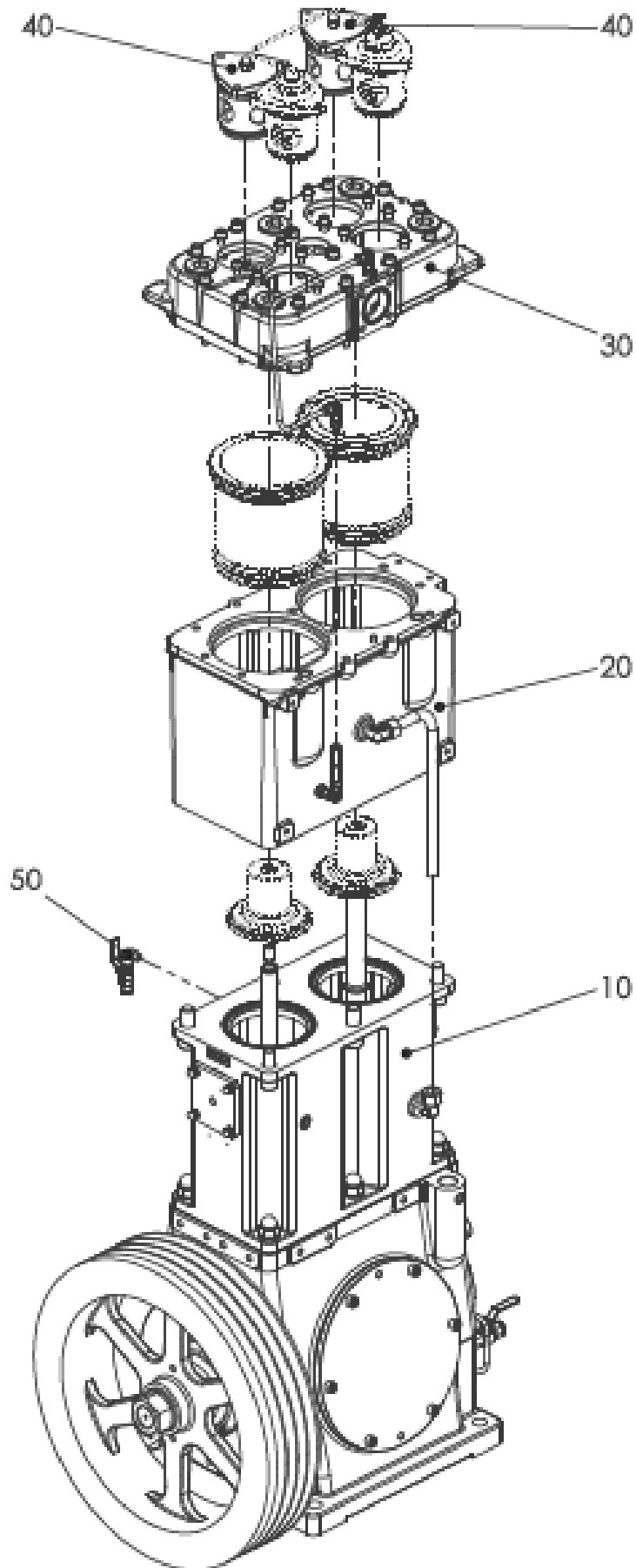

<b>ITEM</b>	<b>PART NO.</b>	<b>DESCRIPTION</b>	<b>QTY</b>
<b>TAG NO.</b>			
		<b>Drawing CC15002 Compressor</b>	
10	17811-CC1511	Gear	1
20	17811-CC1512	Cylinder	1
30	17811-CC1513	Cylinder head	1
40	17811-CC1514	Delivery valve fixture	2
50	17811-CC1515	Condensate drain	1

# Drawing CC15003 Gear

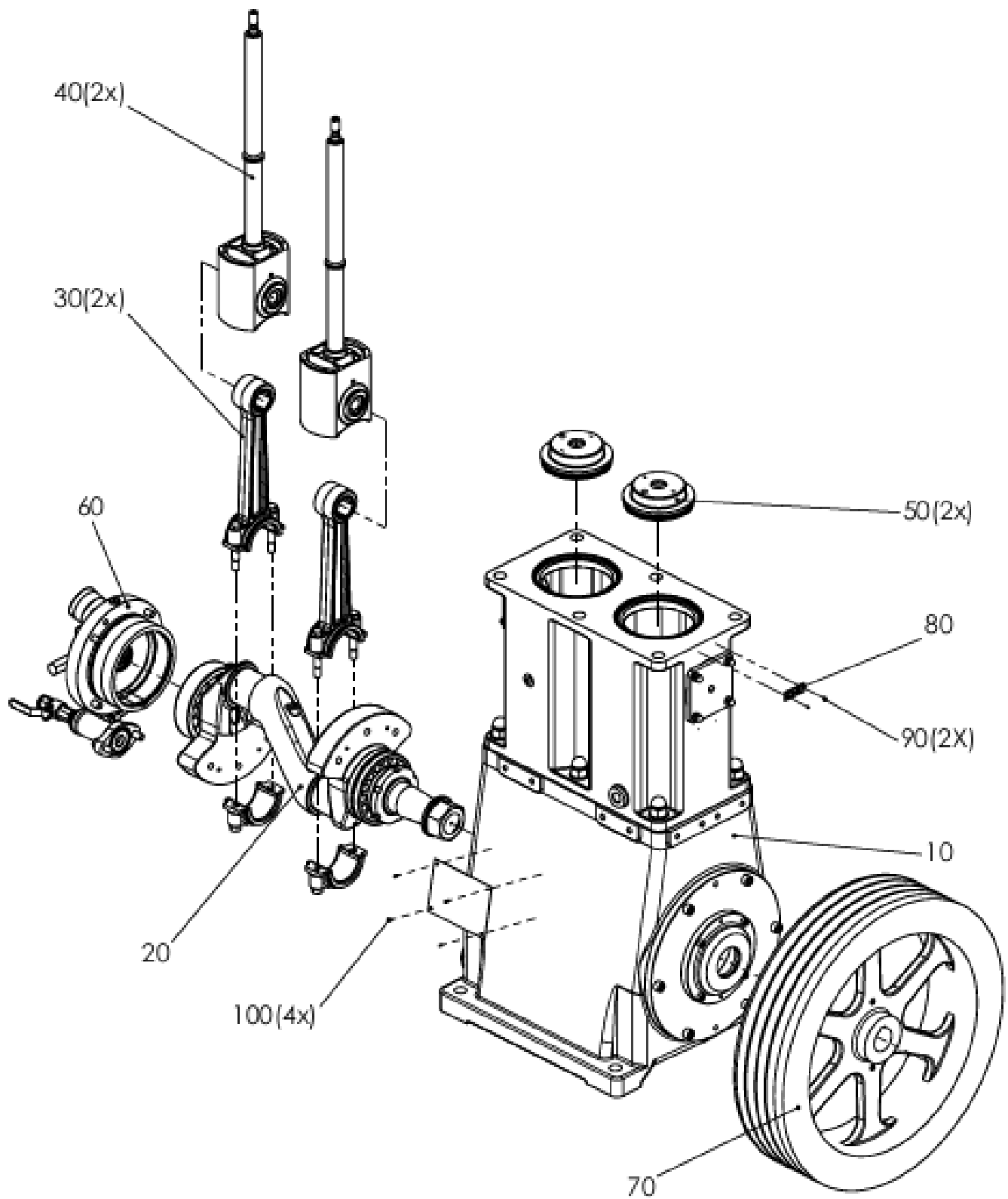

<b>ITEM</b>	<b>PART NO.</b>	<b>DESCRIPTION</b>	<b>QTY</b>
<b>TAG NO.</b>			
		<b>Drawing CC15003 Gear</b>	
10	17811-CC1516	Crankcase	1
20	17811-CC1517	Crankshaft	1
30	17811-CC1518	Connecting rod	2
40	17811-CC1519	Guide piston	2
50	17811-CC1520	Gland, oil	2
60	17811-CC1521	Lubrication	1
70	17811-CC1522	V-belt pulley	1
80	17811-CC1523	Plate	1
90	17811-CC1524	Round head bolt	2
100	17811-CC1525	Round head bolt	4
110	17811-CC1526	Oil	7

# Drawing CC15004 Crankcase

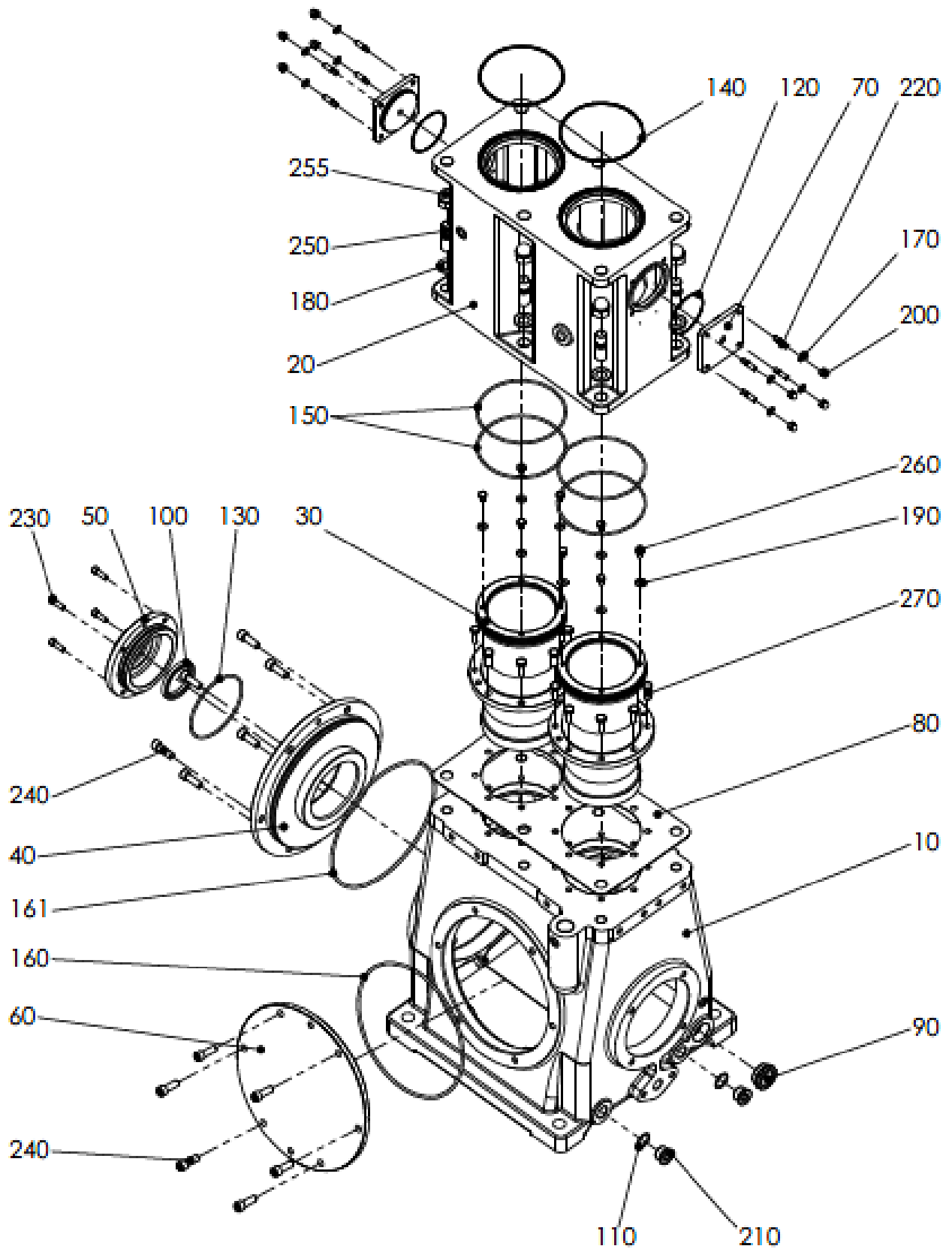

<b>ITEM</b>	<b>PART NO.</b>	<b>DESCRIPTION</b>	<b>QTY</b>
<b>TAG NO.</b>			
		<b>Drawing CC15004 Crankcase</b>	
10	17811-CC1527	Case	1
20	17811-CC1528	Lantern	1
30	17811-CC1529	Cylinder liner	2
40	17811-CC1530	Bearing cap	1
50	17811-CC1531	Sealing cover	1
60	17811-CC1532	Side cover	1
70	17811-CC1533	Cover	2
80	17811-CC1534	Gasket	1
90	17811-CC1535	Oil inspection glass	1
100	17811-CC1536	Radial oil seal gasket	1
110	17811-CC1537	Sealing ring	2
120	17811-CC1538	O-ring	2
130	17811-CC1539	O-ring	1
140	17811-CC1540	O-ring	2
150	17811-CC1541	O-ring	4
160	17811-CC1542	O-ring	1
161	17811-CC1543	O-ring	1
170	17811-CC1544	Washer	8
180	17811-CC1545	Washer	6
190	17811-CC1546	Conical spring washer	8
200	17811-CC1547	Cap nut	8
210	17811-CC1548	Screw plug	2
220	17811-CC1549	Stud	8
230	17811-CC1550	Hexagon socket h.c. screw	4
240	17811-CC1551	Hexagon socket h.c. screw	12
250	17811-CC1552	Stud	6
255	17811-CC1553	Cap nut	6
260	17811-CC1554	Hexagon screw	8
270	17811-CC1555	Hexagon screw	16

# Drawing CC15005 Crankshaft

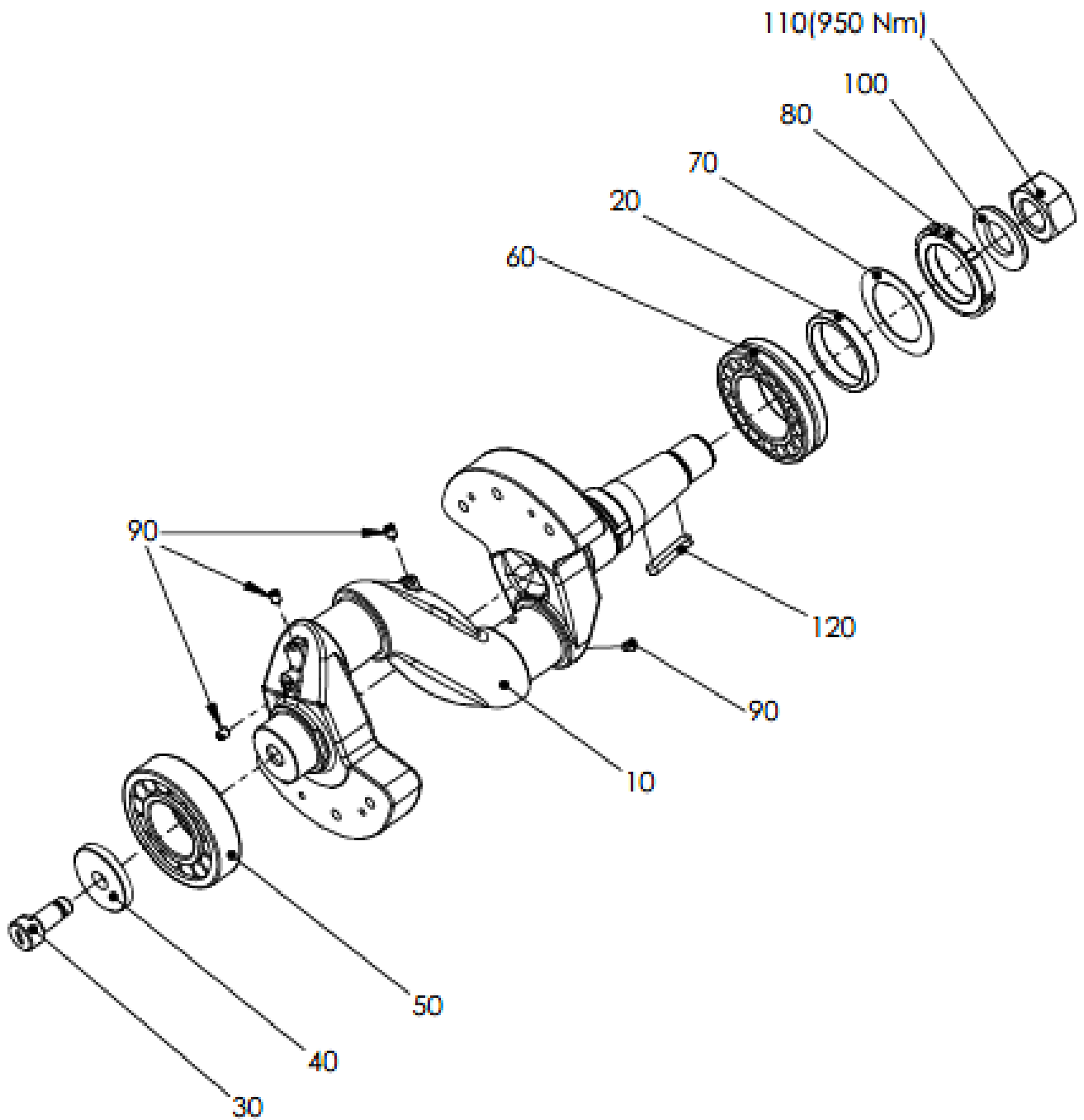

<b>ITEM</b>	<b>PART NO.</b>	<b>DESCRIPTION</b>	<b>QTY</b>
<b>TAG NO.</b>			
		<b>Drawing CC15005 Crankshaft</b>	
10	17811-CC1556	PT Crankshaft	1
20	17811-CC1557	Distance ring	1
30	17811-CC1558	Coupling pin	1
40	17811-CC1559	Washer	1
50	17811-CC1560	Roller bearing	1
60	17811-CC1561	Self-aligning roller bearing	1
70	17811-CC1562	Tab washer	1
80	17811-CC1563	Groove nut	1
90	17811-CC1564	Set screw	4
100	17811-CC1565	Washer	1
110	17811-CC1566	Hexagon nut	1
120	17811-CC1567	Feather key	1

# Drawing CC15006 Guide piston

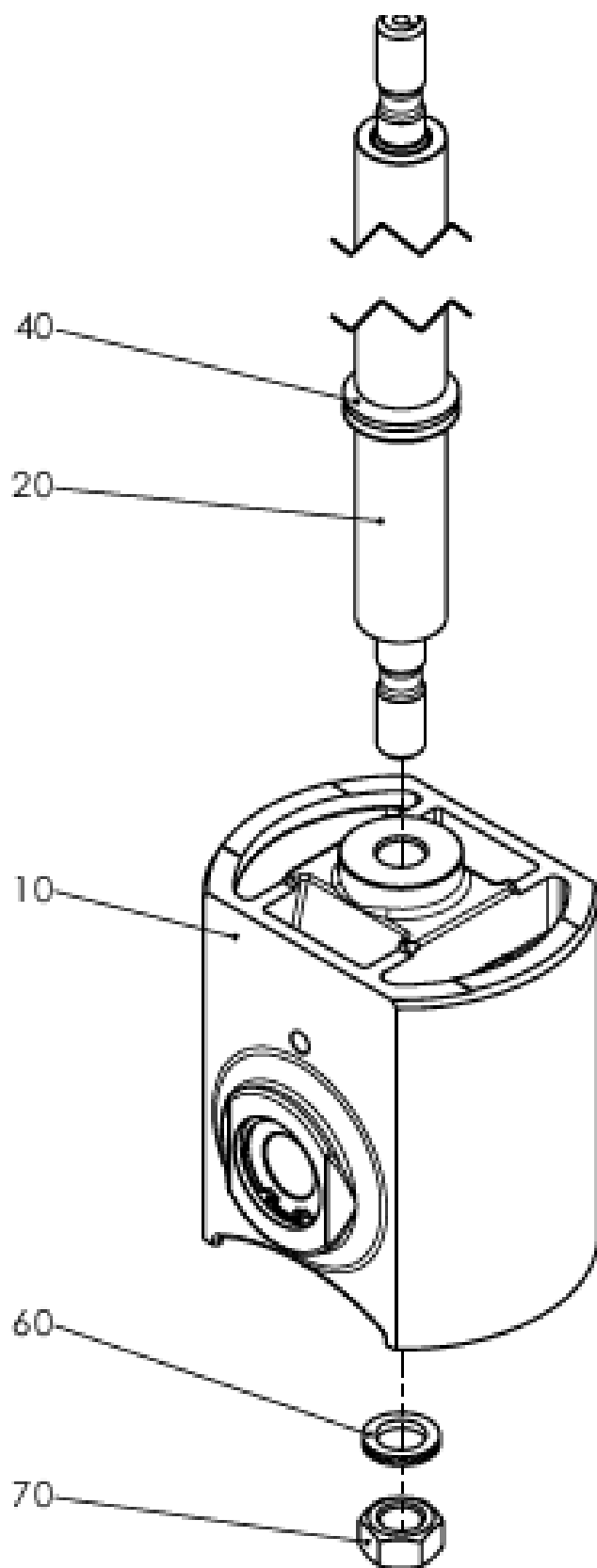

<b>ITEM</b>	<b>PART NO.</b>	<b>DESCRIPTION</b>	<b>QTY</b>
<b>TAG NO.</b>			
		<b>Drawing CC15006 Guide piston</b>	
10	17811-CC1568	Guide piston	1
20	17811-CC1569	Piston rod	1
40	17811-CC1570	V-ring	1
60	17811-CC1571	Wedge lock washer	1
70	17811-CC1572	Hexagon nut	1

# Drawing CC15007 Gland oil

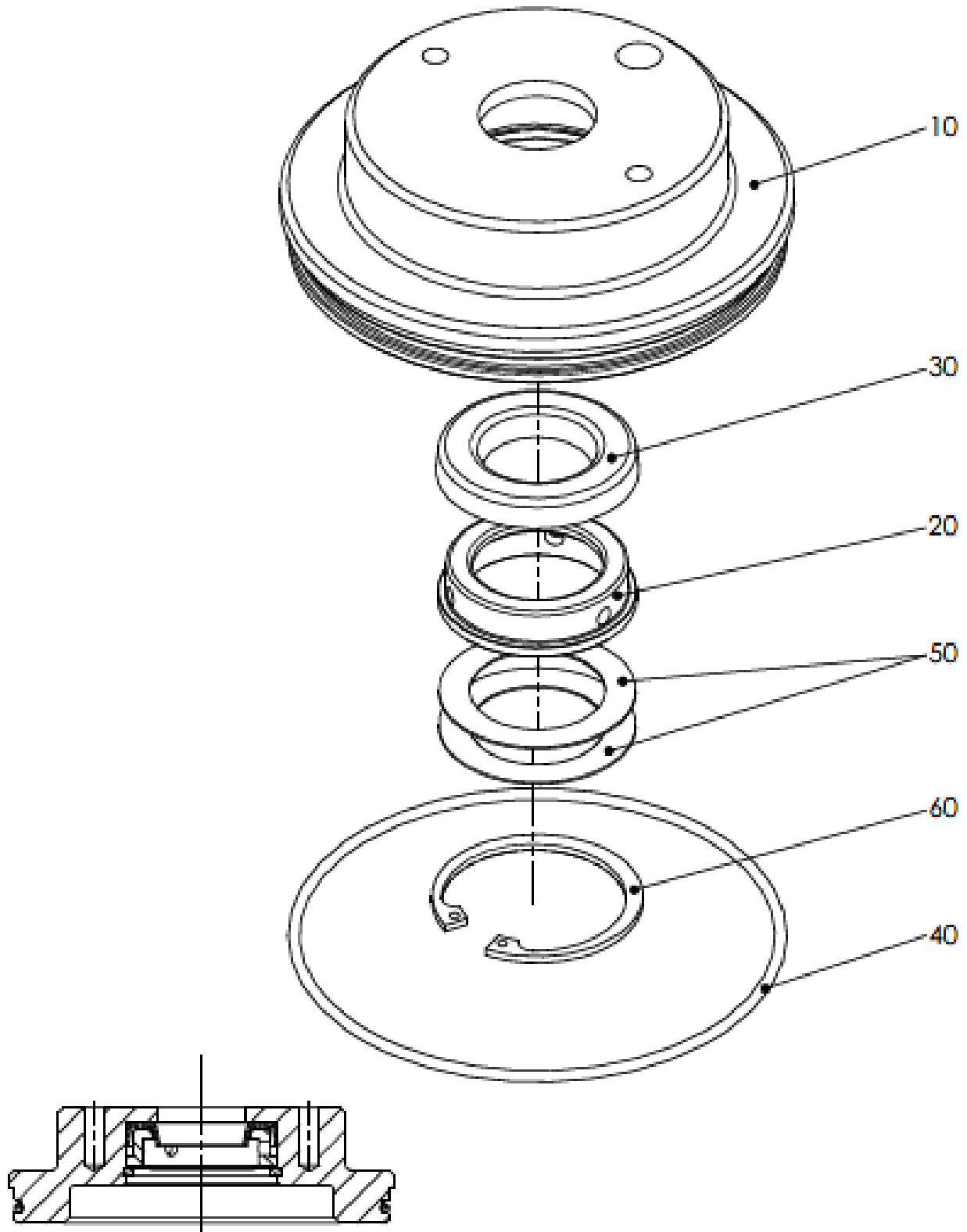

<b>ITEM</b>	<b>PART NO.</b>	<b>DESCRIPTION</b>	<b>QTY</b>
<b>TAG NO.</b>			
		<b>Drawing CC15007 Gland oil</b>	
10	17811-CC1573	Gland housing	1
20	17811-CC1574	Supporting ring	1
30	17811-CC1575	Scraper collar	1
40	17811-CC1576	O-ring	1
50	17811-CC1577	Belleville spring washer	2
60	17811-CC1578	Circlip	1

Drawing CC15008 Lubrication

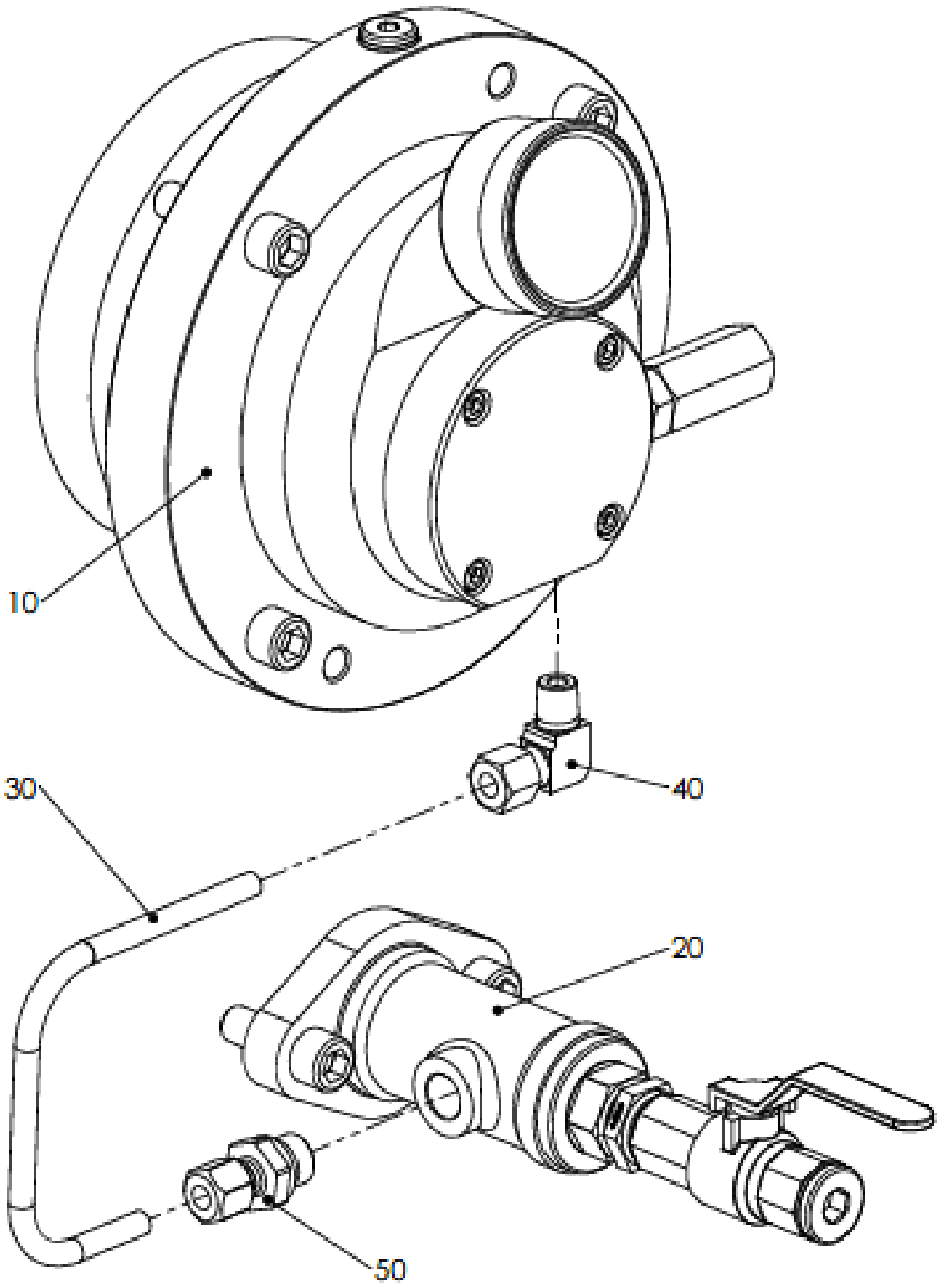

<b>ITEM</b>	<b>PART NO.</b>	<b>DESCRIPTION</b>	<b>QTY</b>
<b>TAG NO.</b>			
		<b>Drawing CC15008 Lubrication</b>	
10	17811-CC1579	Oilpump cpl.	1
20	17811-CC1580	Filter	1
30	17811-CC1581	Pipeline	1
40	17811-CC1582	Angular threaded joint	1
50	17811-CC1583	Threaded joint	1

# Drawing CC15009 Oil pump cpl.

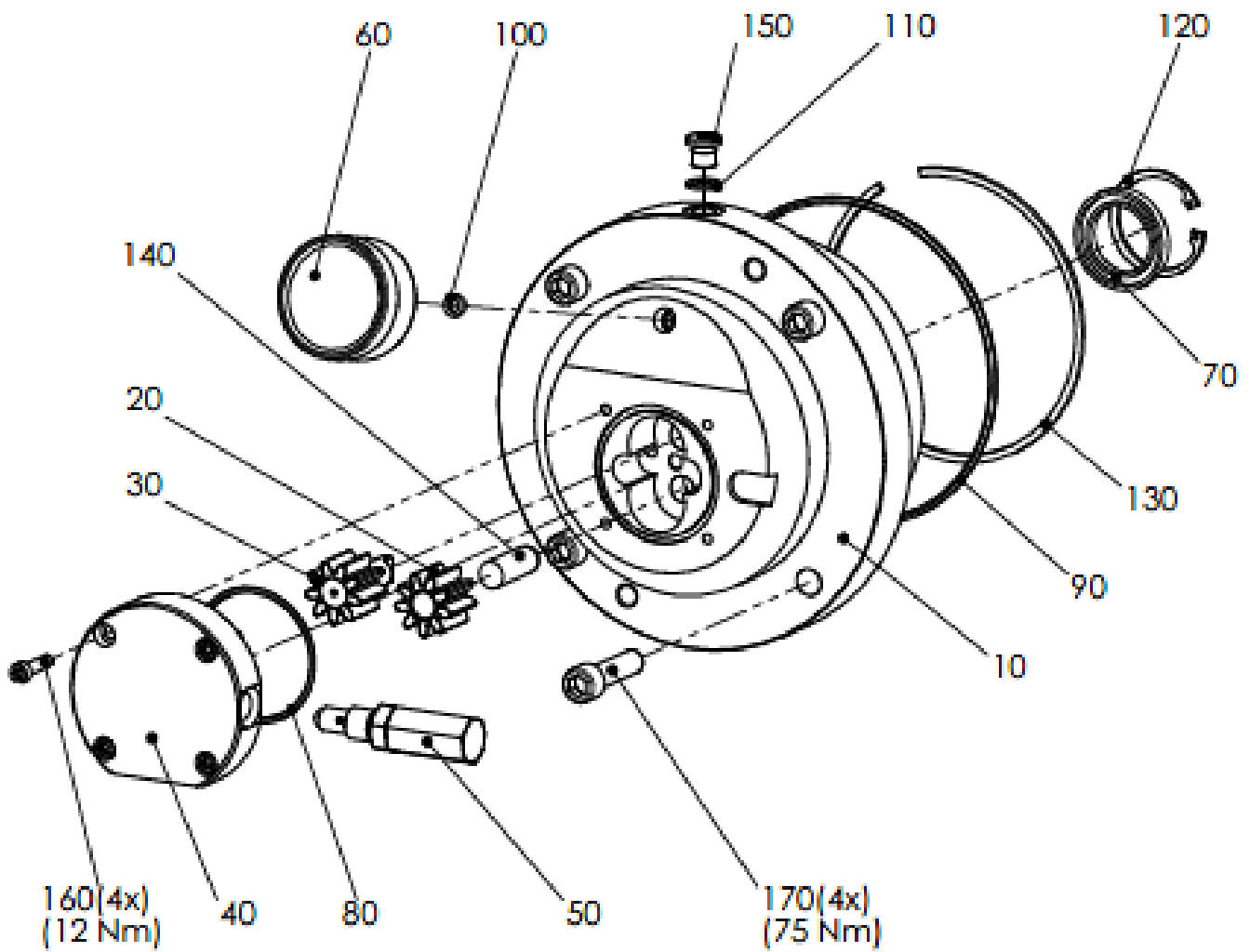

<b>ITEM</b>	<b>PART NO.</b>	<b>DESCRIPTION</b>	<b>QTY</b>
<b>TAG NO.</b>			
		<b>Drawing CC15009 Oil pump cpl.</b>	
10	17811-CC1584	Bearing cap	1
20	17811-CC1585	Toothed gear	1
30	17811-CC1586	Toothed gear	1
40	17811-CC1587	Pump cover	1
50	17811-CC1588	Pressure regulator	1
60	17811-CC1589	Manometer	1
70	17811-CC1590	Radial oil seal gasket	1
80	17811-CC1591	O-ring	1
90	17811-CC1592	O-ring	1
100	17811-CC1593	Sealing ring	1
110	17811-CC1594	Sealing ring	1
120	17811-CC1595	Circlip	1
130	17811-CC1596	Snap ring	1
140	17811-CC1597	Straight pin	1
150	17811-CC1598	Screw plug	1
160	17811-CC1599	Hexagon socket h.c. screw	4
170	17811-CC1600	Hexagon socket h.c. screw	4

Drawing CC15010 Pressure regulator

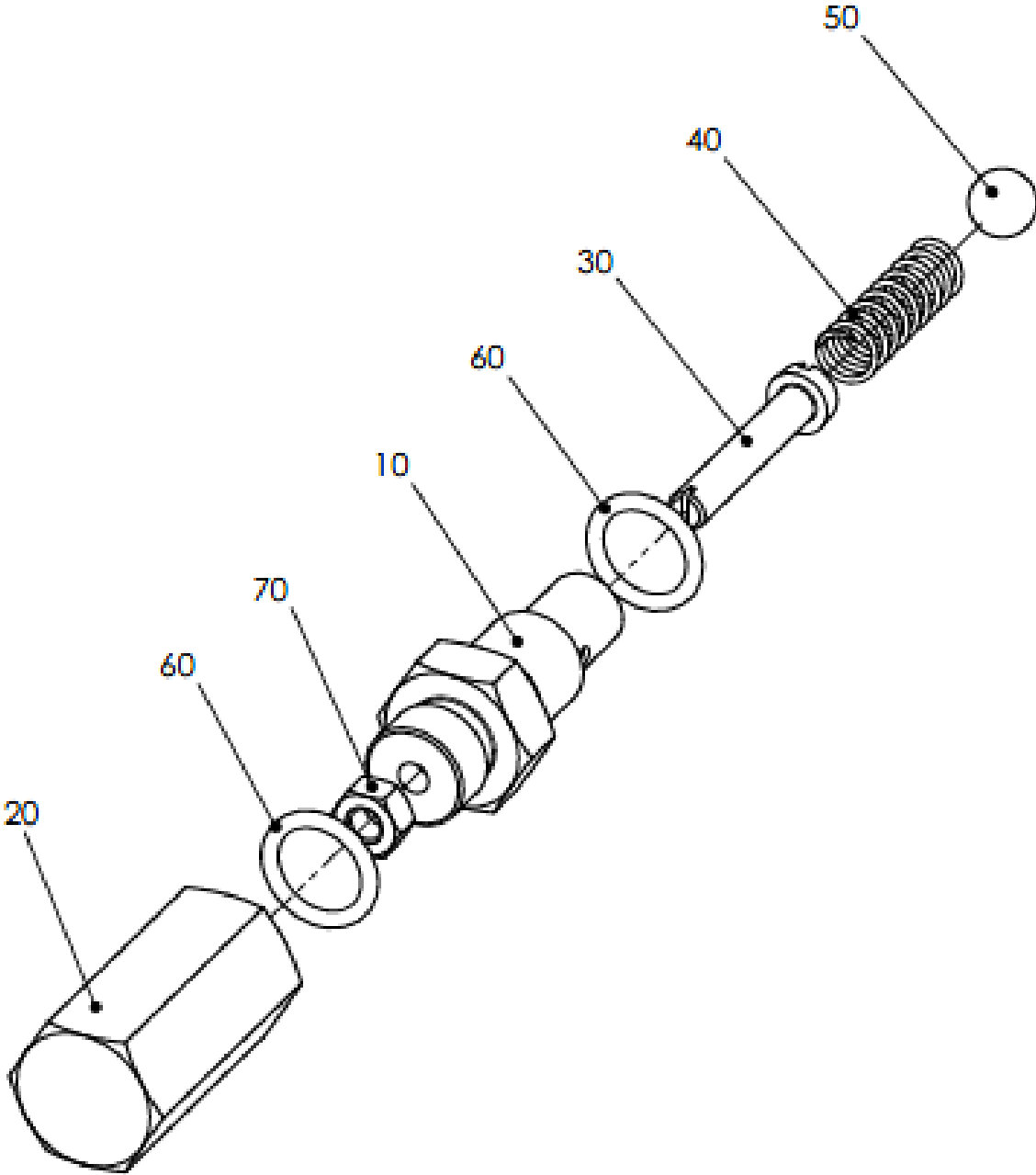

<b>ITEM</b>	<b>PART NO.</b>	<b>DESCRIPTION</b>	<b>QTY</b>
<b>TAG NO.</b>			
		<b>Drawing CC15010 Pressure regulator</b>	
10	17811-CC1601	Valve guide	1
20	17811-CC1602	Cap nut	1
30	17811-CC1603	Adjusting screw	1
40	17811-CC1604	Pressure spring	1
50	17811-CC1605	Ball	1
60	17811-CC1606	O-ring	2
70	17811-CC1607	Hexagon nut	1

# Drawing CC15011 Cylinder

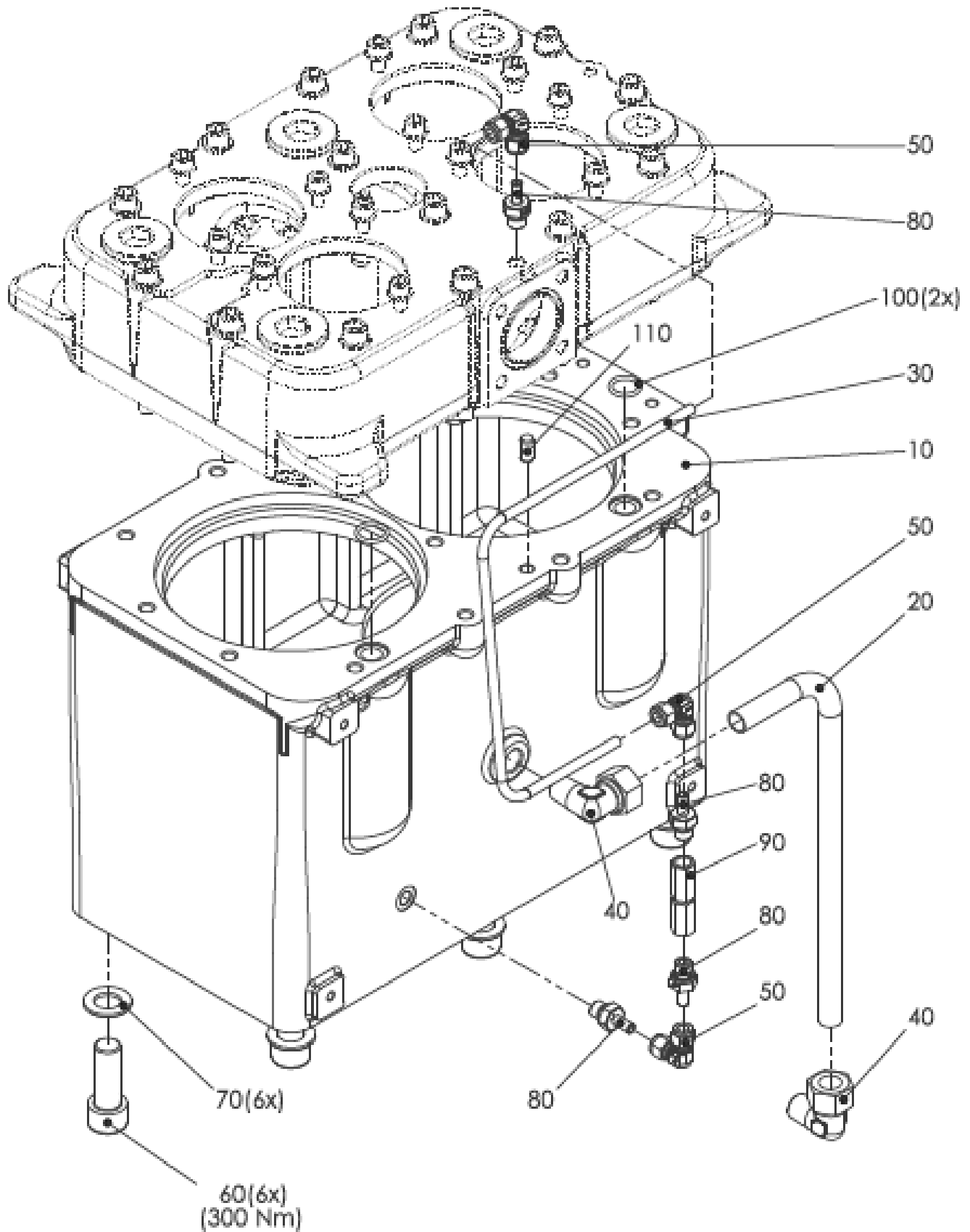

<b>ITEM</b>	<b>PART NO.</b>	<b>DESCRIPTION</b>	<b>QTY</b>
<b>TAG NO.</b>			
		<b>Drawing CC15011 Cylinder</b>	
10	17811-CC1608	Cylinder block	1
20	17811-CC1609	Pipeline	1
30	17811-CC1610	Pipeline	1
40	17811-CC1611	Angular threaded joint	2
50	17811-CC1612	Angular threaded joint	3
60	17811-CC1613	Hexagon socket h.c. screw	6
70	17811-CC1614	Washer	6
80	17811-CC1615	Tube adapter	4
90	17811-CC1616	Non return valve	1
100	17811-CC1617	O-ring	2
110	17811-CC1618	Straight pin	1

Drawing CC15012 Non return valve

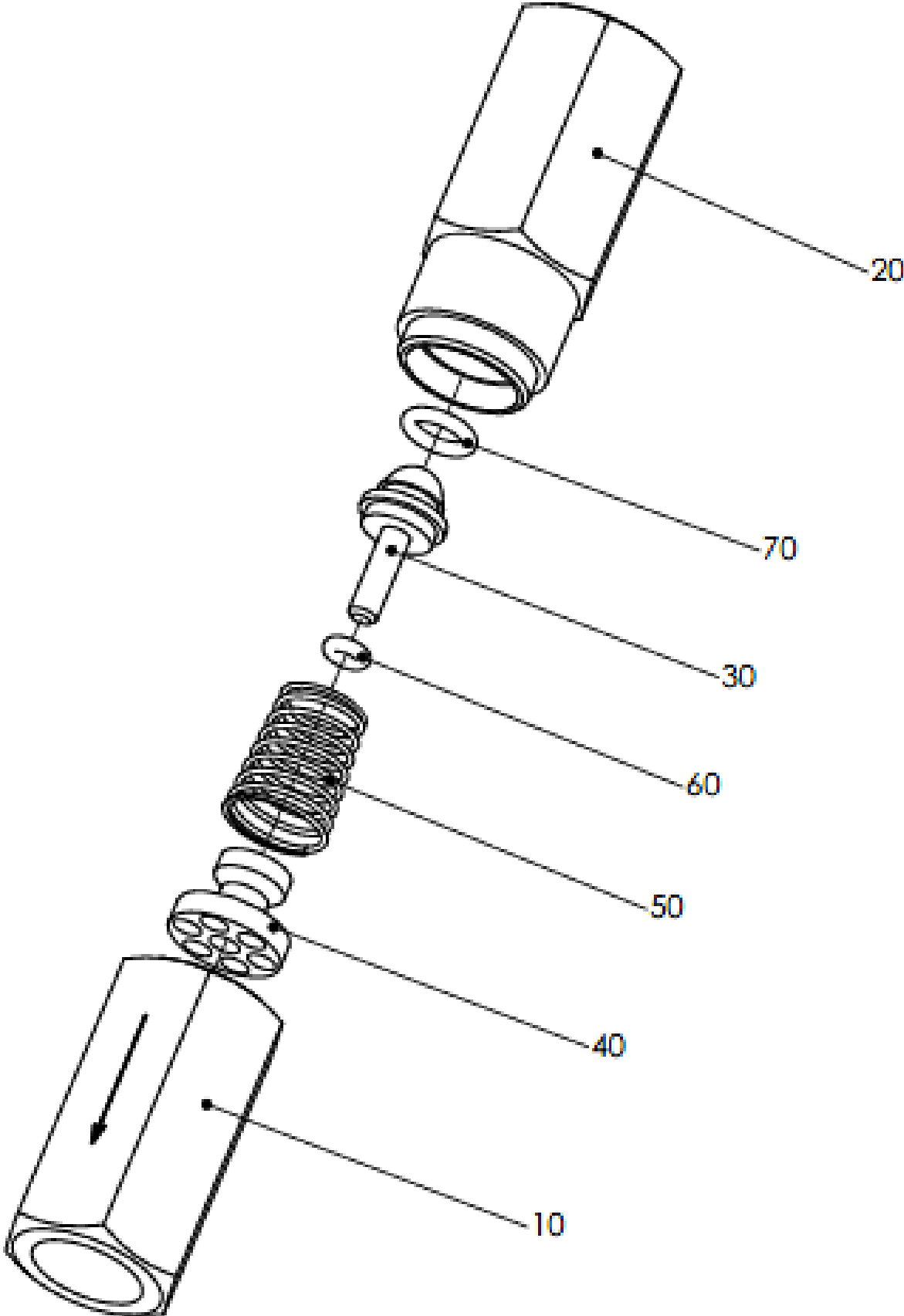

<b>ITEM</b>	<b>PART NO.</b>	<b>DESCRIPTION</b>	<b>QTY</b>
<b>TAG NO.</b>			
		<b>Drawing CC15012 Non return valve</b>	
10	17811-CC1619	Valve body	1
20	17811-CC1620	Valve body	1
30	17811-CC1621	Valve cone	1
40	17811-CC1622	Valve bushing	1
50	17811-CC1623	Pressure spring	1
60	17811-CC1624	O-ring	1
70	17811-CC1625	O-ring	1

# Drawing CC15013 Cylinder head

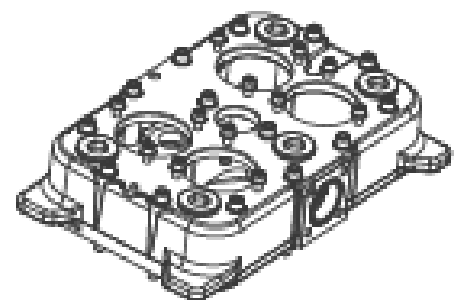
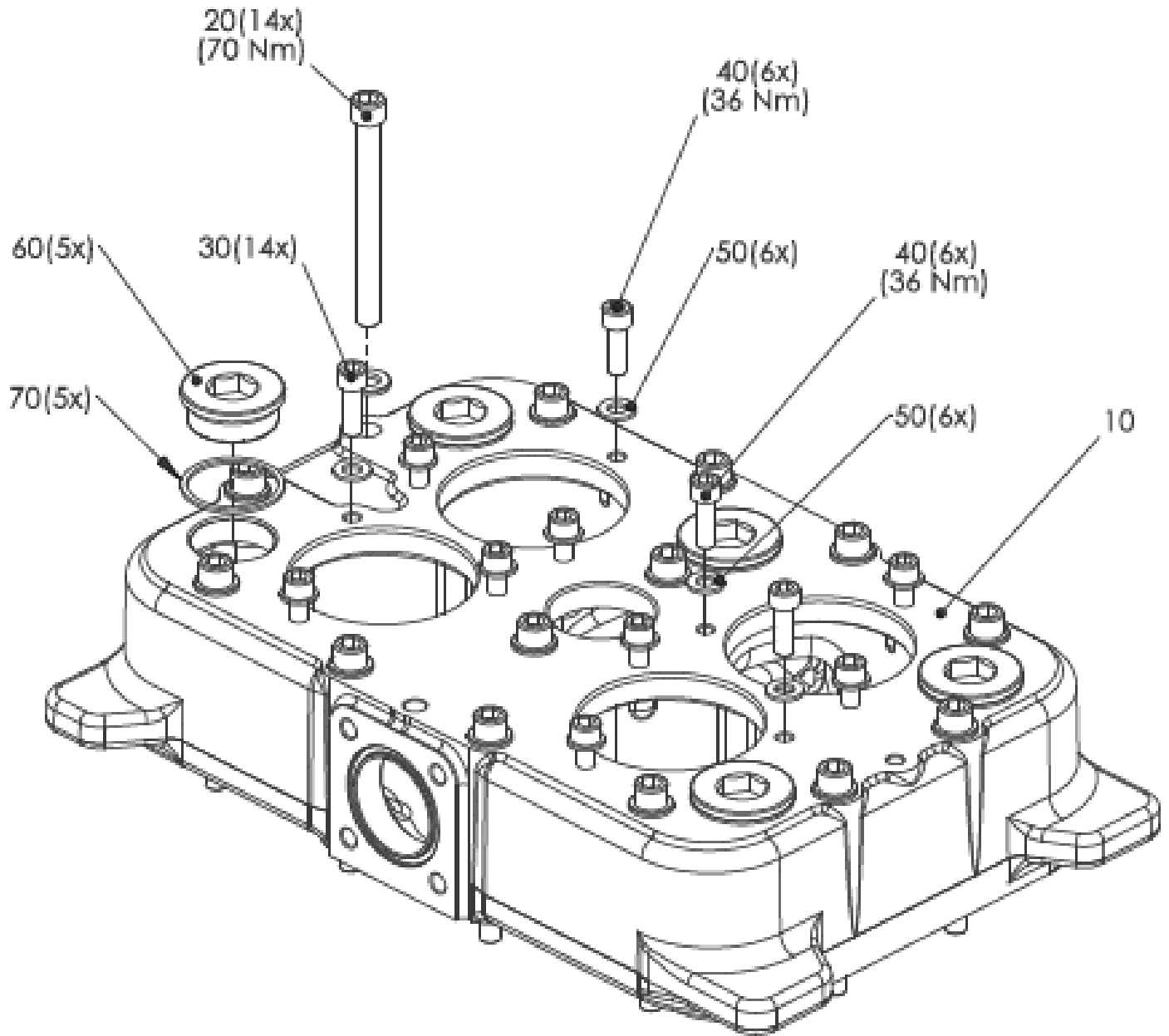

<b>ITEM</b>	<b>PART NO.</b>	<b>DESCRIPTION</b>	<b>QTY</b>
<b>TAG NO.</b>			
		<b>Drawing CC15013 Cylinder head</b>	
10	17811-CC1626	Cylinder head	1
20	17811-CC1627	Hexagon socket h.c. screw	14
30	17811-CC1628	Washer	14
40	17811-CC1629	Hexagon socket h.c. screw	12
50	17811-CC1630	Washer	12
60	17811-CC1631	Screw plug	5
70	17811-CC1632	Sealing ring	5

# Drawing CC15014 Delivery valve fixture

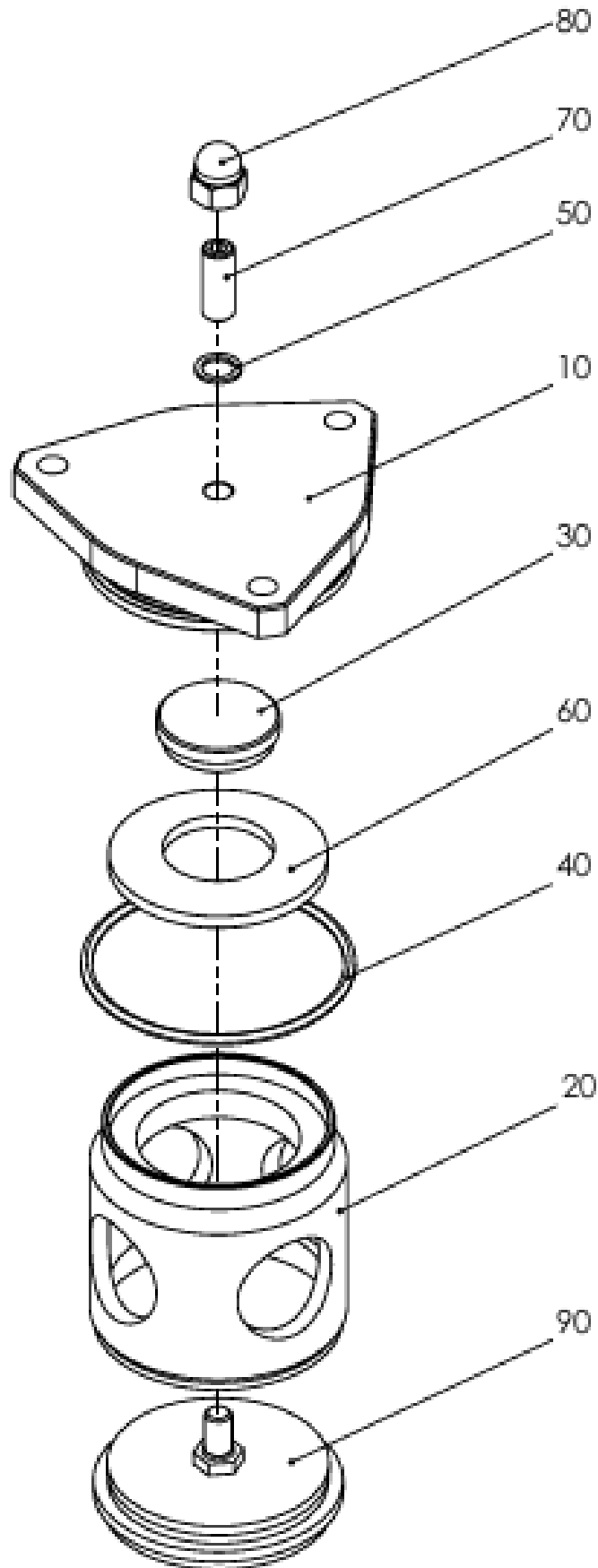

<b>ITEM</b>	<b>PART NO.</b>	<b>DESCRIPTION</b>	<b>QTY</b>
<b>TAG NO.</b>			
		<b>Drawing CC15014 Delivery valve fixture</b>	
10	17811-CC1633	Cover	1
20	17811-CC1634	Valve lantern	1
30	17811-CC1635	Pressure washer	1
40	17811-CC1636	O-ring	1
50	17811-CC1637	Sealing ring	1
60	17811-CC1638	Belleville spring washer	1
70	17811-CC1639	Set screw	1
80	17811-CC1640	Cap nut	1
90	17811-CC1641	see 1.assy Pos. 30.2 resp. 30	1

Drawing CC15015 Condensate drain

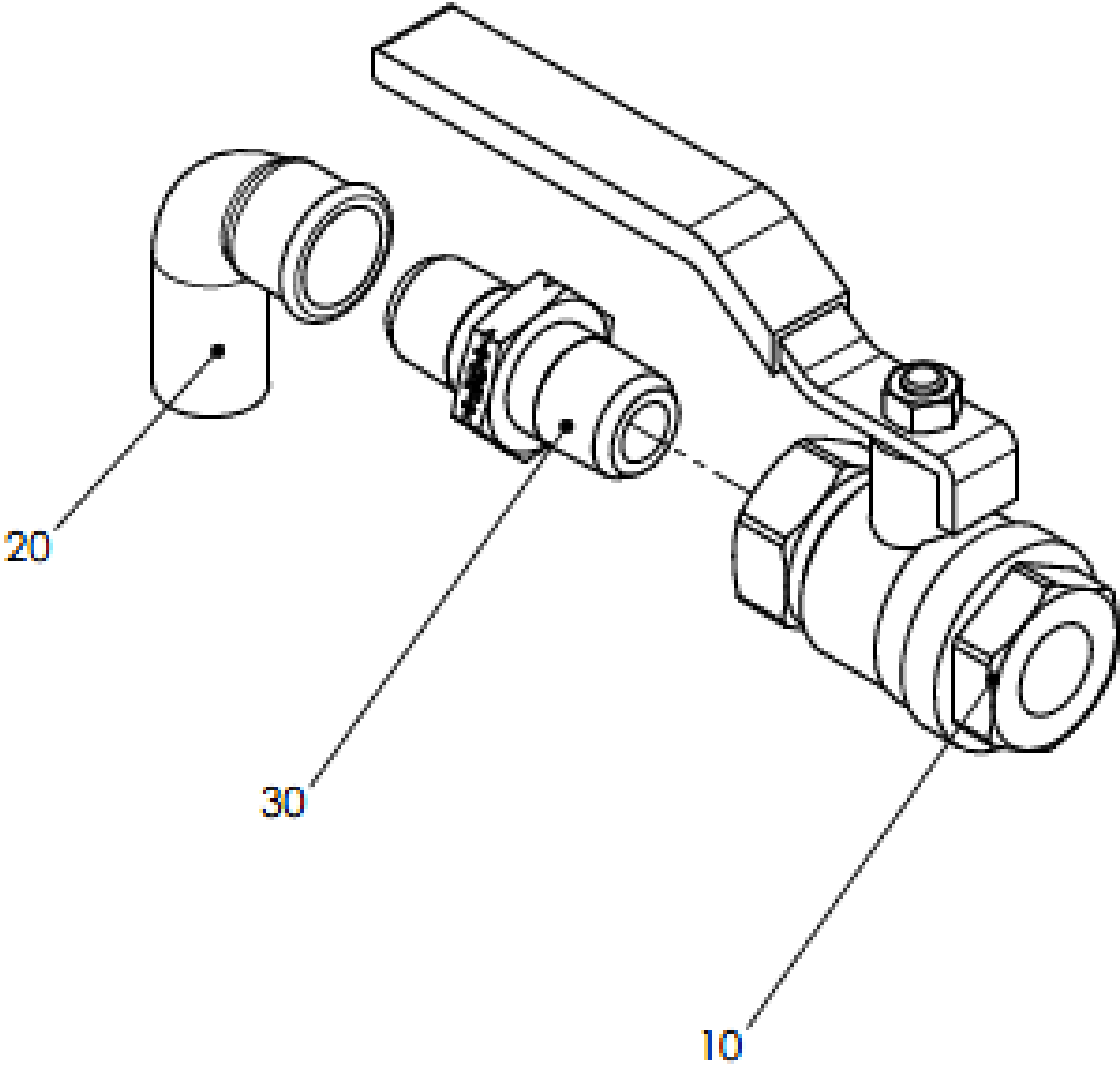

<b>ITEM</b>	<b>PART NO.</b>	<b>DESCRIPTION</b>	<b>QTY</b>
<b>TAG NO.</b>			
		<b>Drawing CC15015 Condensate drain</b>	
10	17811-CC1642	Ball valve	1
20	17811-CC1643	Angle	1
30	17811-CC1644	Double nipple	1

# Drawing CC15016 Piston and guide rings

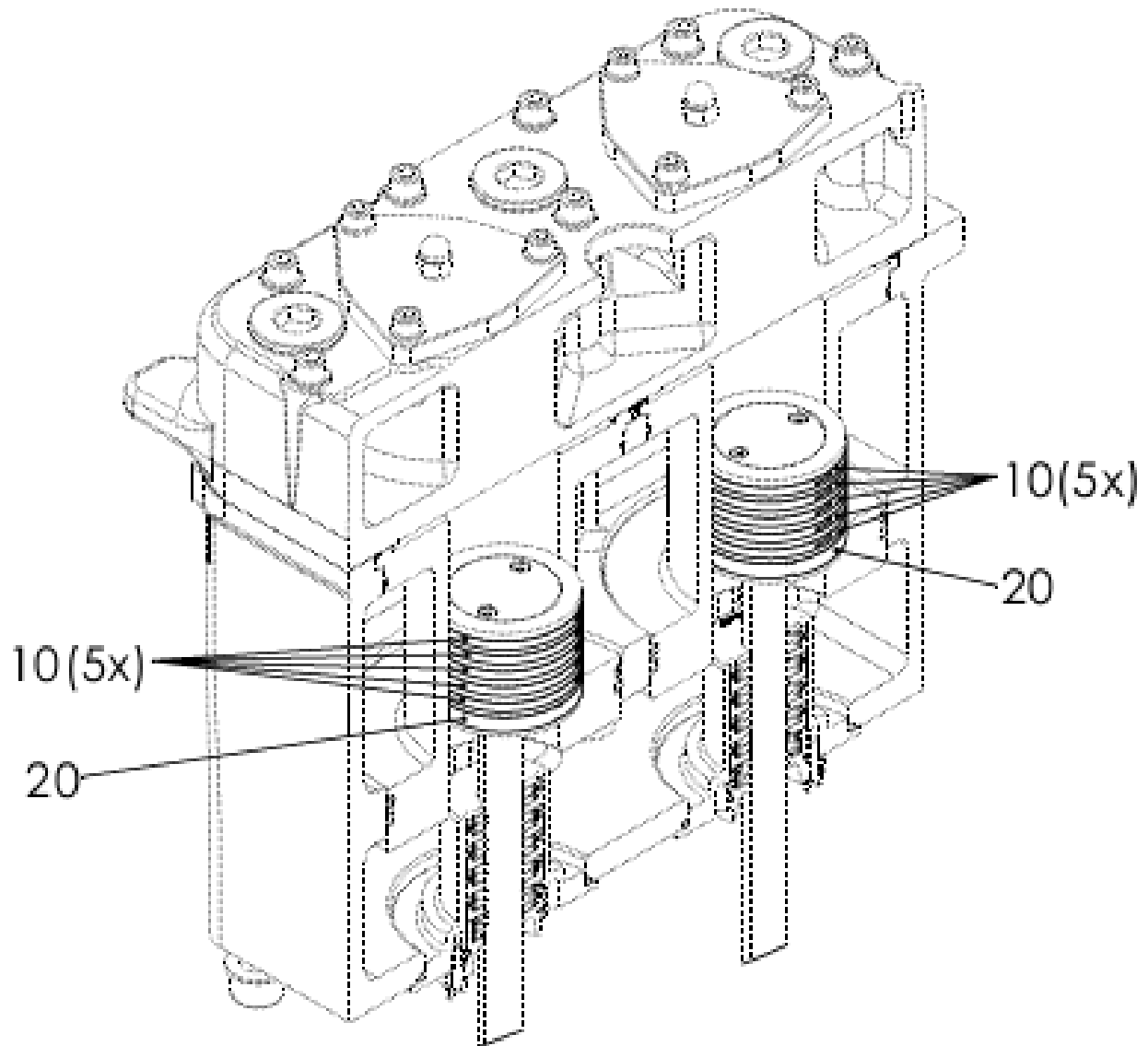

<b>ITEM</b>	<b>PART NO.</b>	<b>DESCRIPTION</b>	<b>QTY</b>
<b>TAG NO.</b>			
		<b>Drawing CC15016 Piston and guide rings</b>	
10	17811-CC1645	Piston ring	10
20	17811-CC1646	Guide ring	2

# Drawing CC15017 Working valves

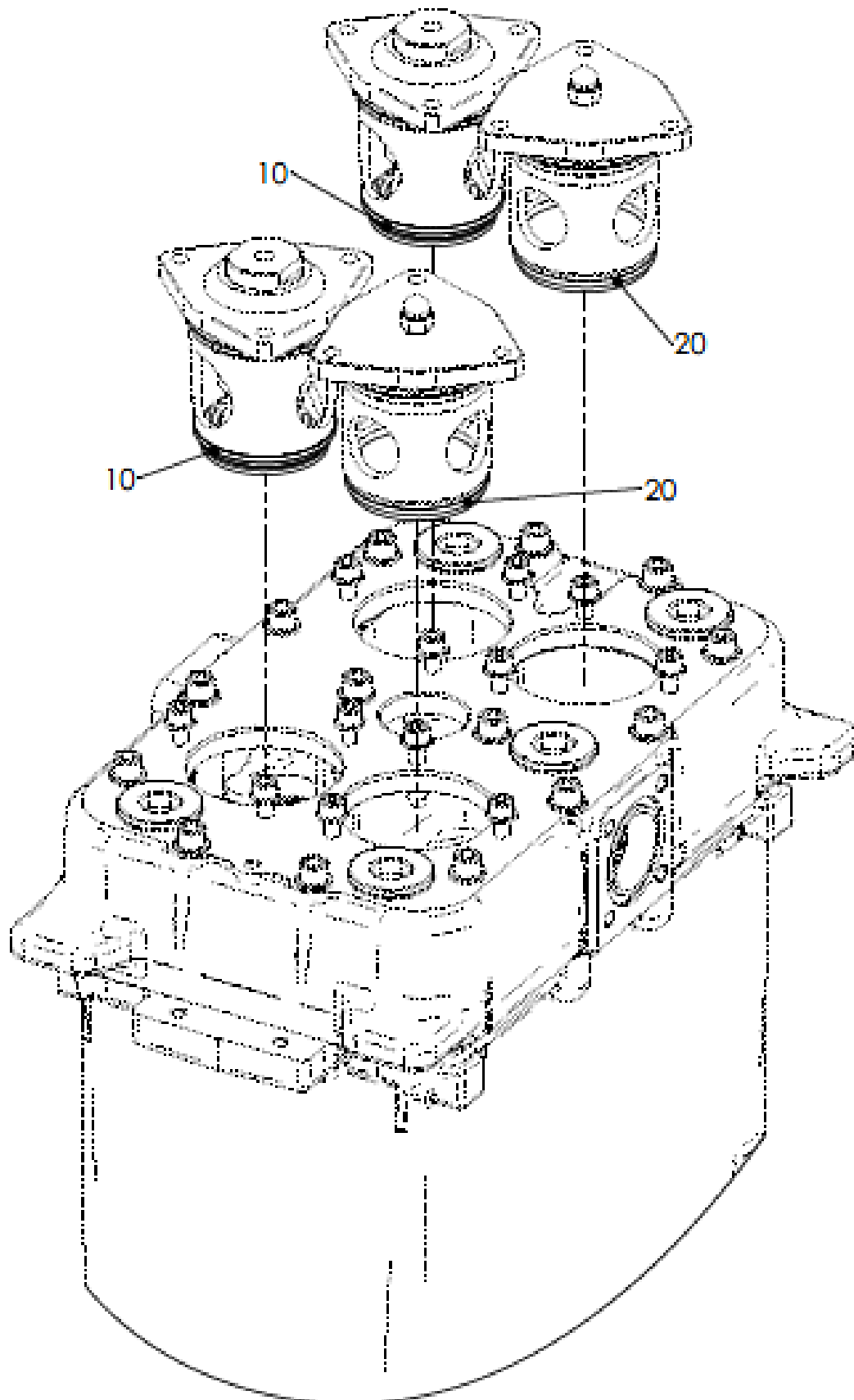

<b>ITEM</b>	<b>PART NO.</b>	<b>DESCRIPTION</b>	<b>QTY</b>
<b>TAG NO.</b>			
		<b>Drawing CC15017 Working valves</b>	
10	17811-CC1647	Suction valve	2
20	17811-CC1648	Delivery valve	2

# Drawing CC15018 Piston

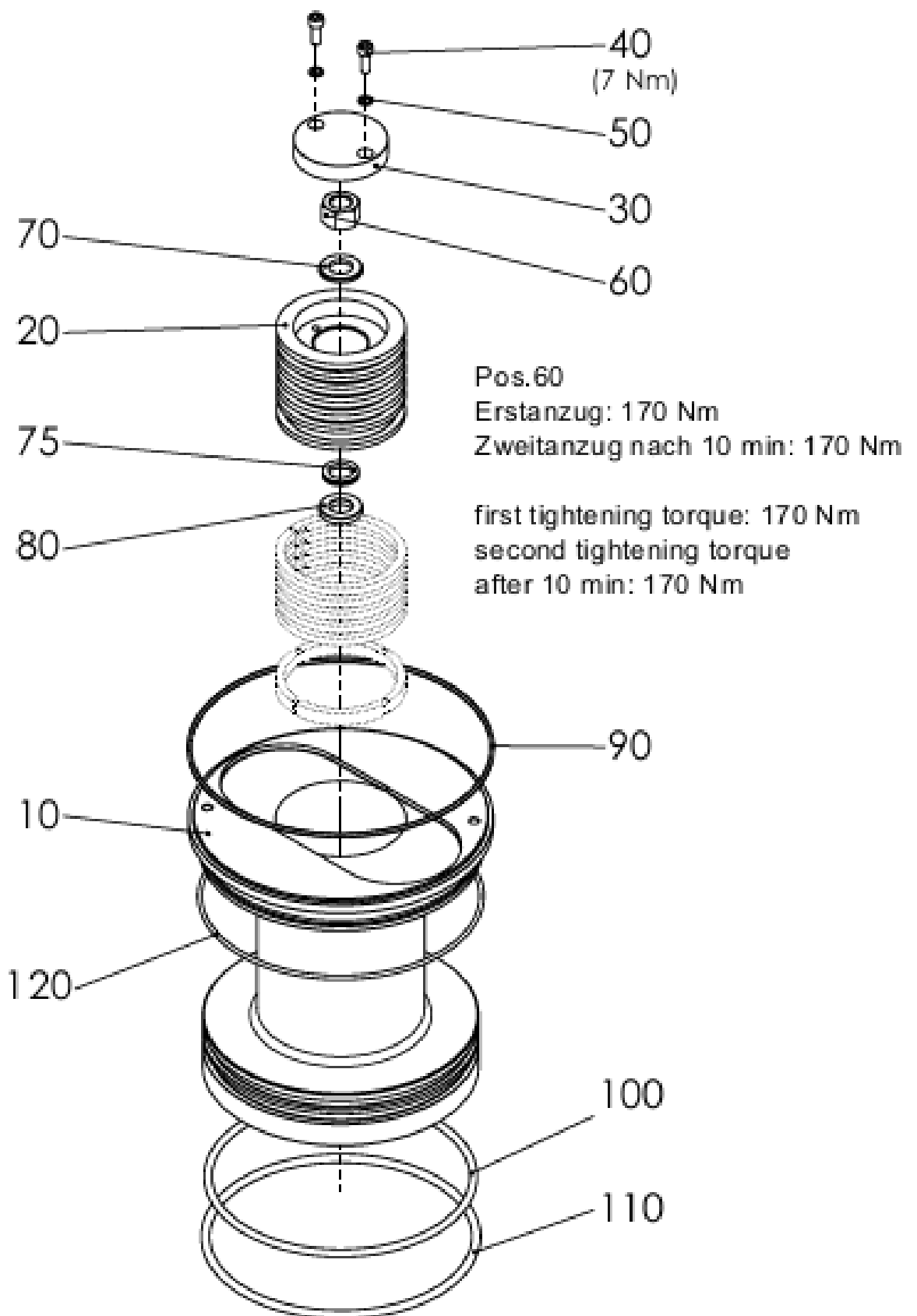

<b>ITEM</b>	<b>PART NO.</b>	<b>DESCRIPTION</b>	<b>QTY</b>
<b>TAG NO.</b>			
		<b>Drawing CC15018 Piston</b>	
10	17811-CC1649	Cylinder liner	1
20	17811-CC1650	Piston barrel	1
30	17811-CC1651	Piston cover	1
40	17811-CC1652	Hexagon socket h.c. screw	2
50	17811-CC1653	Locking washer	2
60	17811-CC1654	Hexagon nut	1
70	17811-CC1655	Washer	1
75	17811-CC1656	Wedge lock washer	1
80	17811-CC1657	Pressure washer	1
90	17811-CC1658	O-ring	1
100	17811-CC1659	O-ring	1
110	17811-CC1660	O-ring	1
120	17811-CC1661	O-ring	1

Drawing CC15019 Gland gas

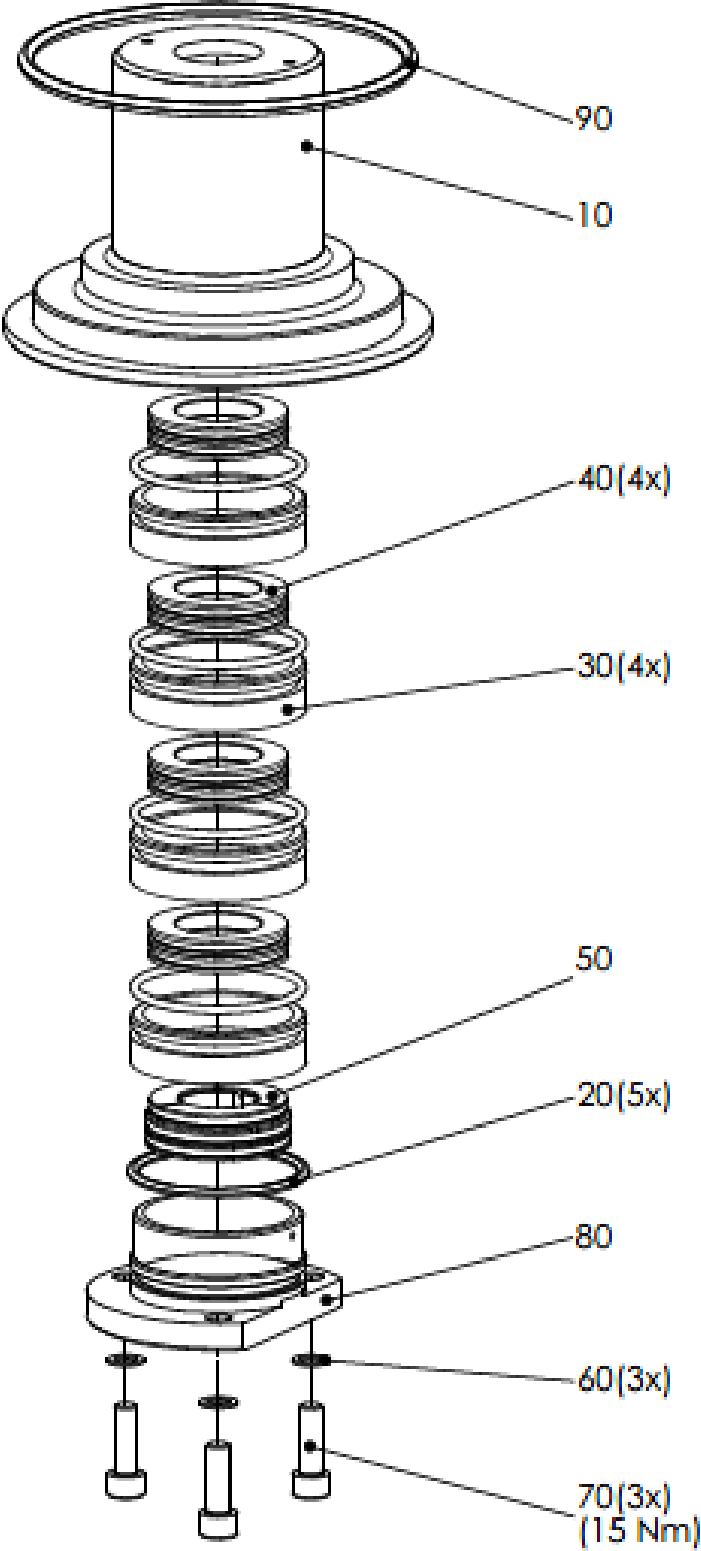

<b>ITEM</b>	<b>PART NO.</b>	<b>DESCRIPTION</b>	<b>QTY</b>
<b>TAG NO.</b>			
		<b>Drawing CC15019 Gland gas</b>	
10	17811-CC1662	Gland housing	1
20	17811-CC1663	O-ring	5
30	17811-CC1664	Gland	4
40	17811-CC1665	Segmental Ring	4
50	17811-CC1666	Segmental ring	1
60	17811-CC1667	Lock plate	3
70	17811-CC1668	Hexagon socket h.c. screw	3
80	17811-CC1669	Gland cover	1
90	17811-CC1670	O-ring	1

Drawing CC15020 Valve control

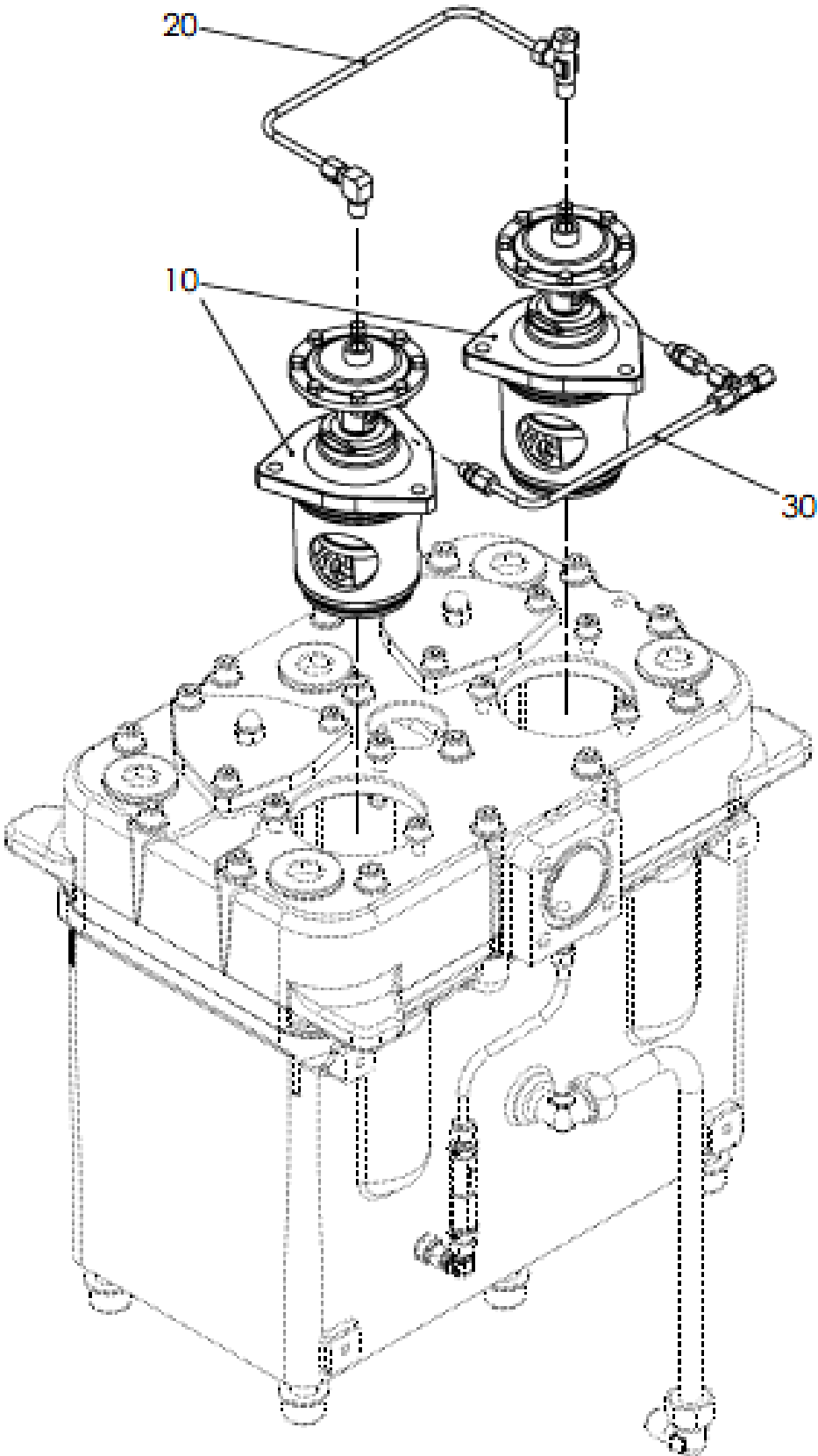

<b>ITEM</b>	<b>PART NO.</b>	<b>DESCRIPTION</b>	<b>QTY</b>
<b>TAG NO.</b>			
		<b>Drawing CC15020 Valve control</b>	
10	17811-CC1671	Valve control	2
20	17811-CC1672	Piping - valve control	1
30	17811-CC1673	Piping - valve control	1
40	17811-CC1674	Plate	1
50	17811-CC1675	Plate	1

# Drawing CC15021 Valve control

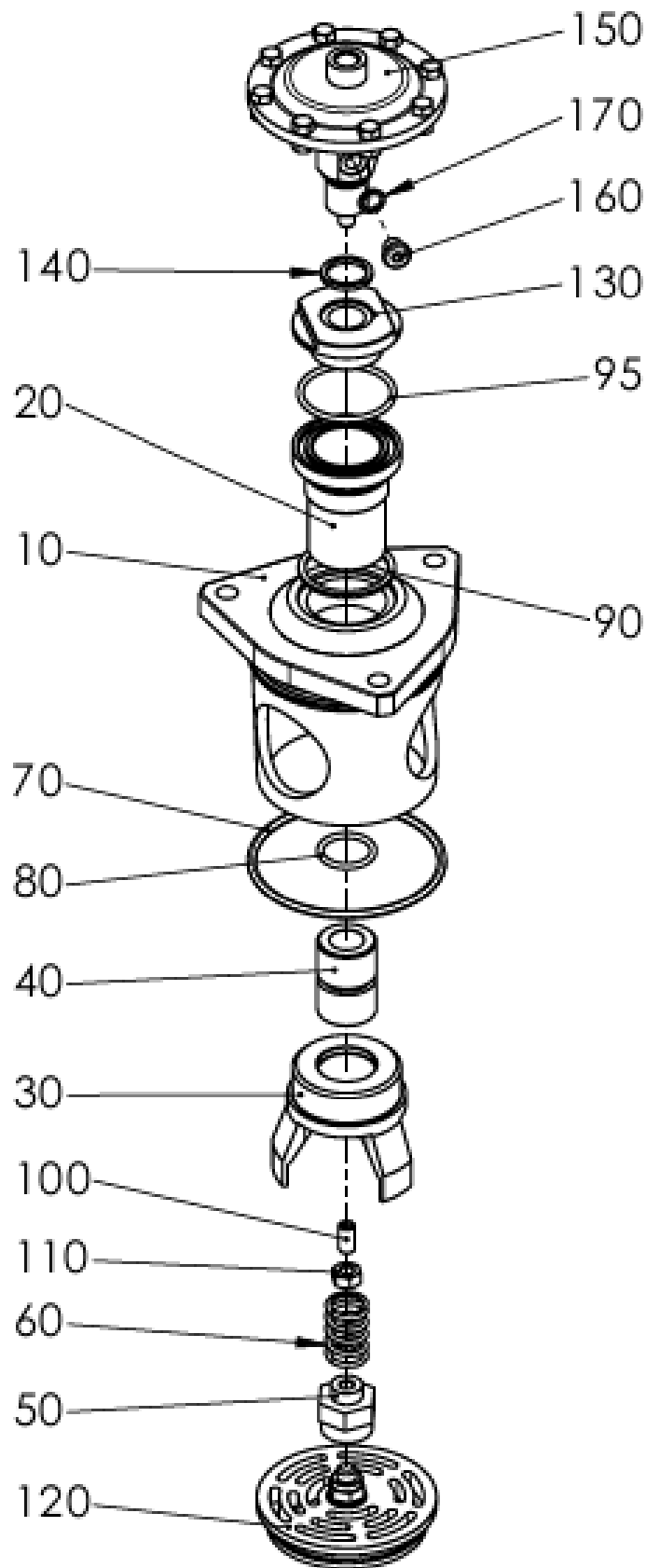

<b>ITEM</b>	<b>PART NO.</b>	<b>DESCRIPTION</b>	<b>QTY</b>
<b>TAG NO.</b>			
		<b>Drawing CC15021 Valve control</b>	
10	17811-CC1676	Cover	1
20	17811-CC1677	Liner	1
30	17811-CC1678	Unloader fork	1
40	17811-CC1679	Unloader piston	1
50	17811-CC1680	Distance bushing	1
60	17811-CC1681	Pressure spring	1
70	17811-CC1682	O-ring	1
80	17811-CC1683	O-ring	1
90	17811-CC1684	Sealing ring	1
95	17811-CC1685	O-ring	1
100	17811-CC1686	Set screw	1
110	17811-CC1687	Hexagon nut	1
120	17811-CC1688	see 1.assy Pos 30.1 resp. 30	1
130	17811-CC1689	Reduction nipple	1
140	17811-CC1690	Sealing ring	1
150	17811-CC1691	Membrane cylinder	1
160	17811-CC1692	Screw plug	1
170	17811-CC1693	Sealing ring	1

# Drawing CC15022 Piping valve control

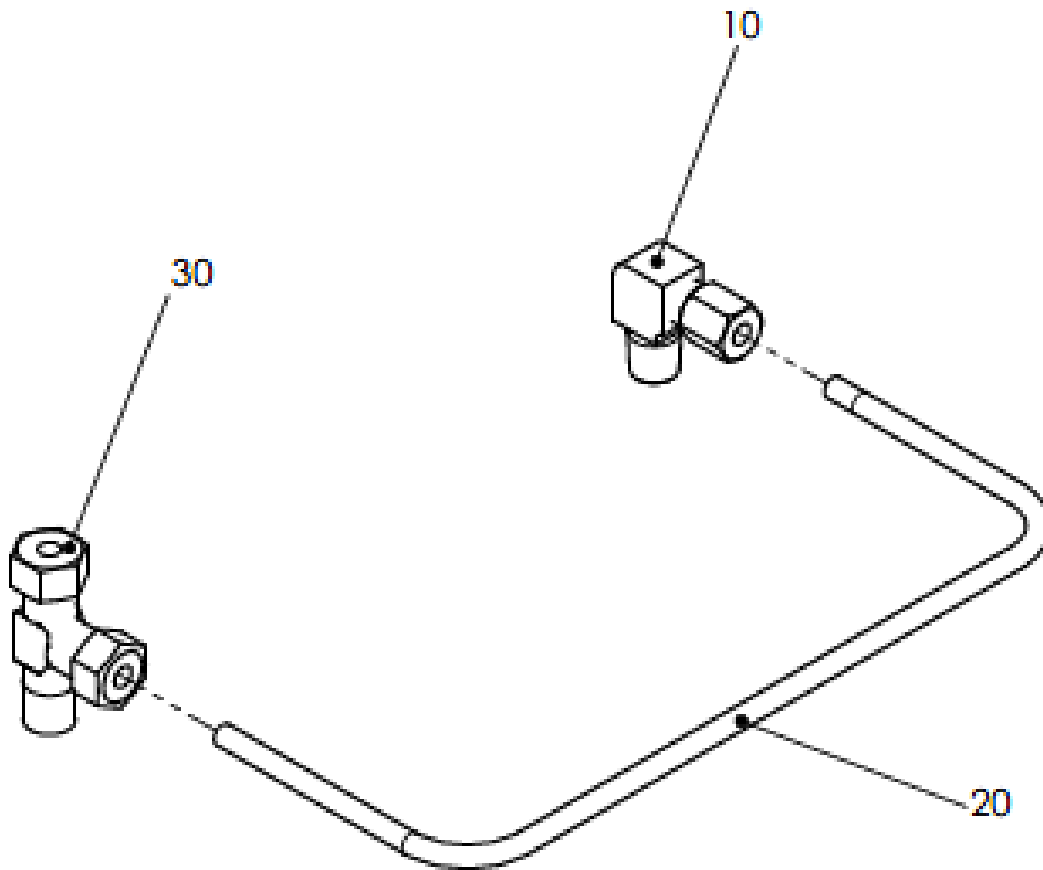

<b>ITEM</b>	<b>PART NO.</b>	<b>DESCRIPTION</b>	<b>QTY</b>
<b>TAG NO.</b>			
		<b>Drawing CC15022 Piping valve control</b>	
10	17811-CC1694	Angular threaded joint	1
20	17811-CC1695	Pipeline	1
30	17811-CC1696	L-threaded joint	1

# Drawing CC15023 Piping valve control

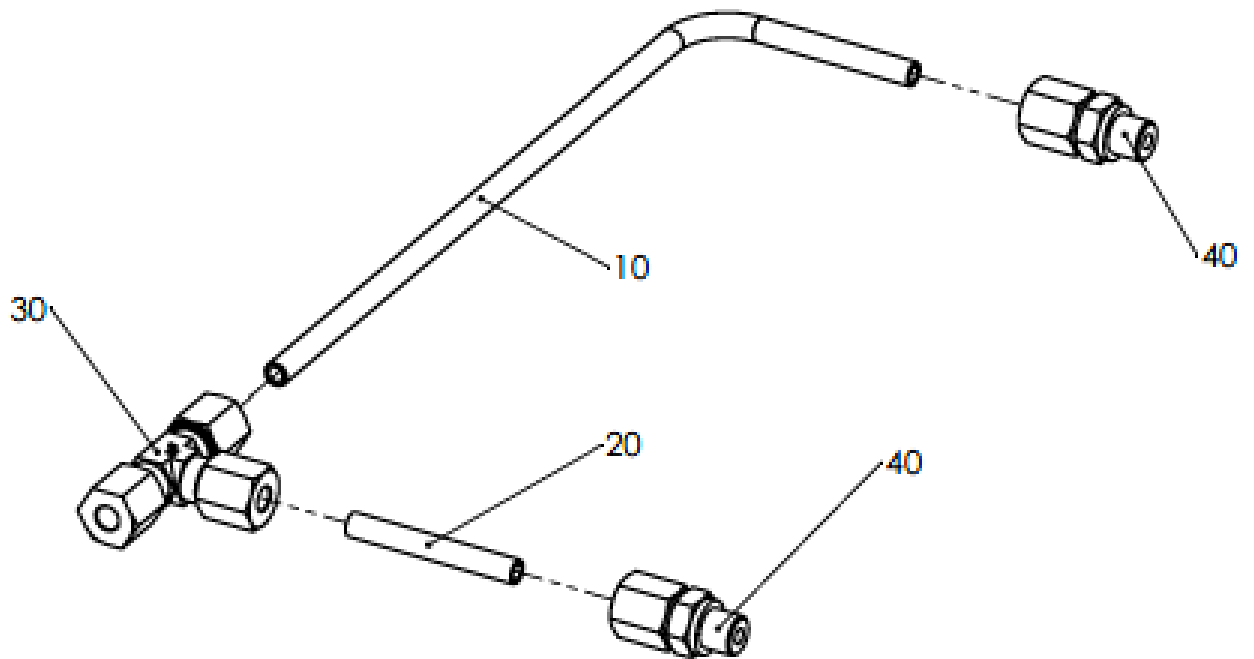
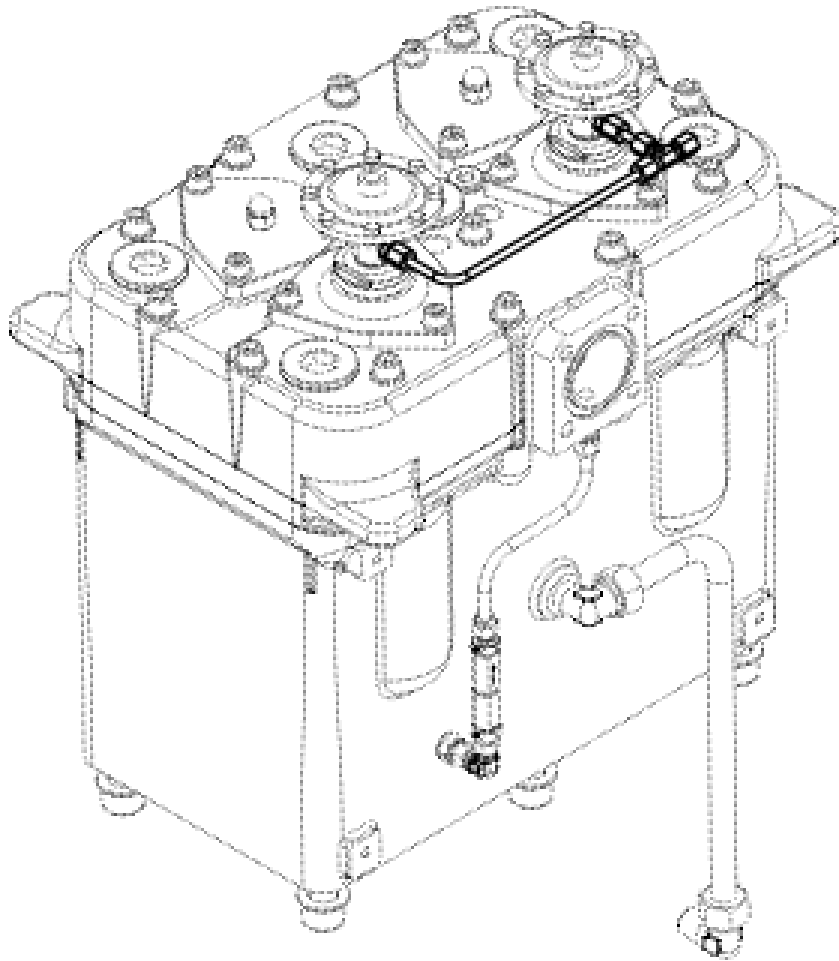

<b>ITEM</b>	<b>PART NO.</b>	<b>DESCRIPTION</b>	<b>QTY</b>
<b>TAG NO.</b>			
		<b>Drawing CC15023 Piping valve control</b>	
10	17811-CC1697	Pipeline	1
20	17811-CC1698	Pipeline	1
30	17811-CC1699	T-screw connection	1
40	17811-CC1700	Threaded joint	2

# Drawing CC15024 Leak gas gland

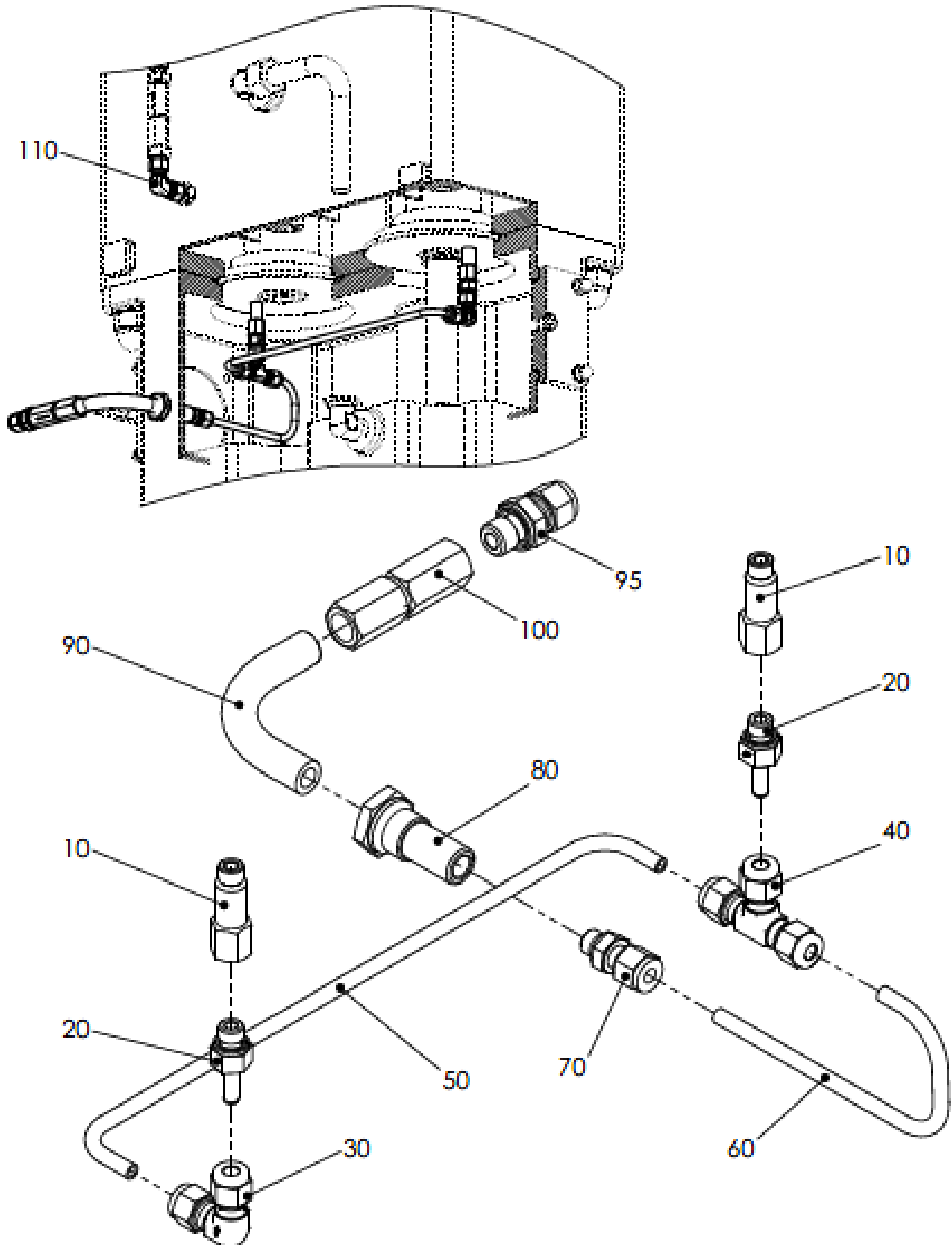

<b>ITEM</b>	<b>PART NO.</b>	<b>DESCRIPTION</b>	<b>QTY</b>
<b>TAG NO.</b>			
		<b>Drawing CC15024 Leak gas gland</b>	
10	17811-CC1701	Screwing socket	2
20	17811-CC1702	Tube adapter	2
30	17811-CC1703	Angular threaded joint	1
40	17811-CC1704	T-screw connection	1
50	17811-CC1705	Pipeline	1
60	17811-CC1706	Pipeline	1
70	17811-CC1707	Straight connection	1
80	17811-CC1708	Screwing socket	1
90	17811-CC1709	Bow	1
95	17811-CC1710	Straight connection	1
100	17811-CC1711	Non return valve	1

Drawing CC15025 Non return valve

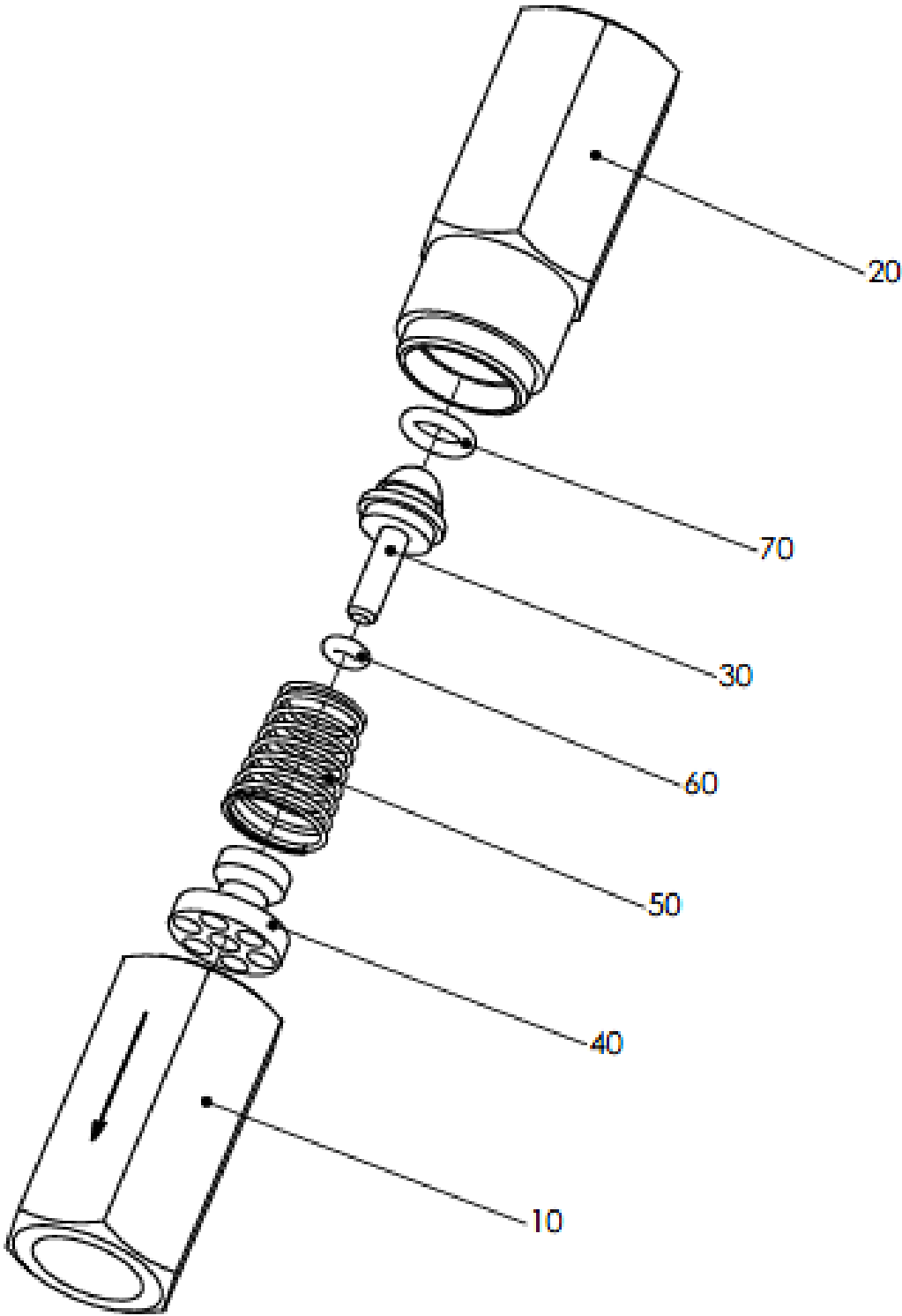

<b>ITEM</b>	<b>PART NO.</b>	<b>DESCRIPTION</b>	<b>QTY</b>
<b>TAG NO.</b>			
		<b>Drawing CC15025 Non return valve</b>	
10	17811-CC1712	Valve body	1
20	17811-CC1713	Valve body	1
30	17811-CC1714	Valve cone	1
40	17811-CC1715	Valve bushing	1
50	17811-CC1716	Pressure spring	1
60	17811-CC1717	O-ring	1
70	17811-CC1718	O-ring	1

# Drawing CC15026 Leak gas latern

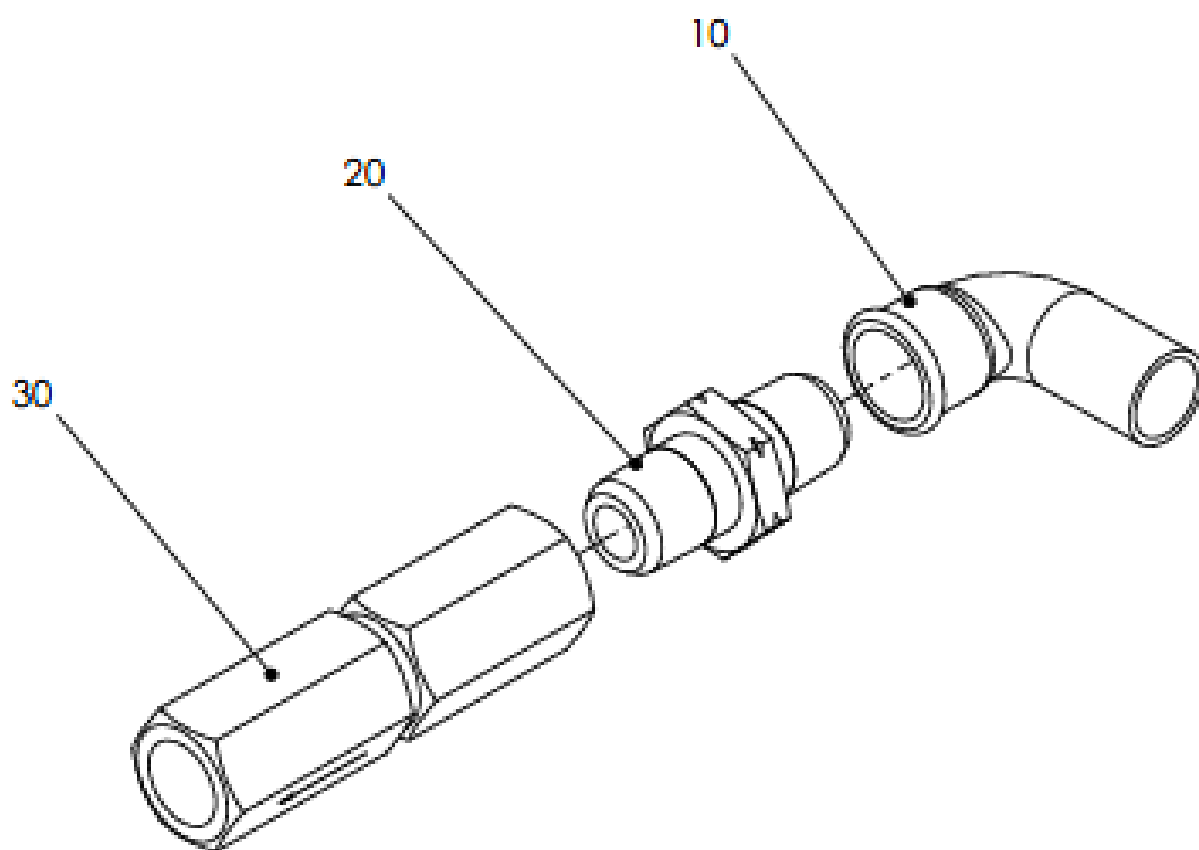

<b>ITEM</b>	<b>PART NO.</b>	<b>DESCRIPTION</b>	<b>QTY</b>
<b>TAG NO.</b>			
		<b>Drawing CC15026 Leak gas latern</b>	
10	17811-CC1719	Angle	1
20	17811-CC1720	Double nipple	1
30	17811-CC1721	Non return valve	1

Drawing CC15027 Non return valve

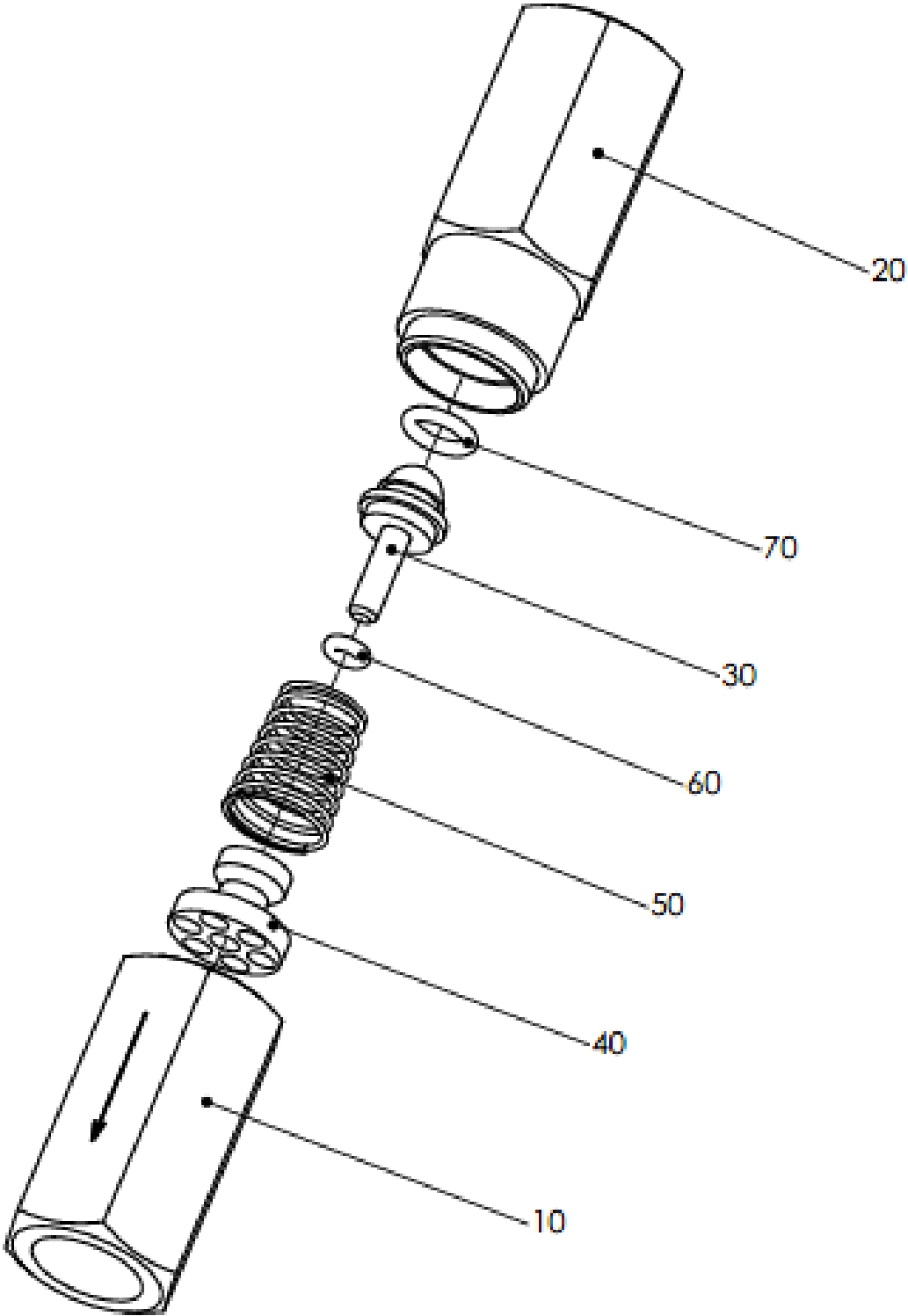

<b>ITEM</b>	<b>PART NO.</b>	<b>DESCRIPTION</b>	<b>QTY</b>
<b>TAG NO.</b>			
		<b>Drawing CC15027 Non return valve</b>	
10	17811-CC1722	Valve body	1
20	17811-CC1723	Valve body	1
30	17811-CC1724	Valve cone	1
40	17811-CC1725	Valve bushing	1
50	17811-CC1726	Pressure spring	1
60	17811-CC1727	O-ring	1
70	17811-CC1728	O-ring	1

# Drawing CC15028 Without purging gas

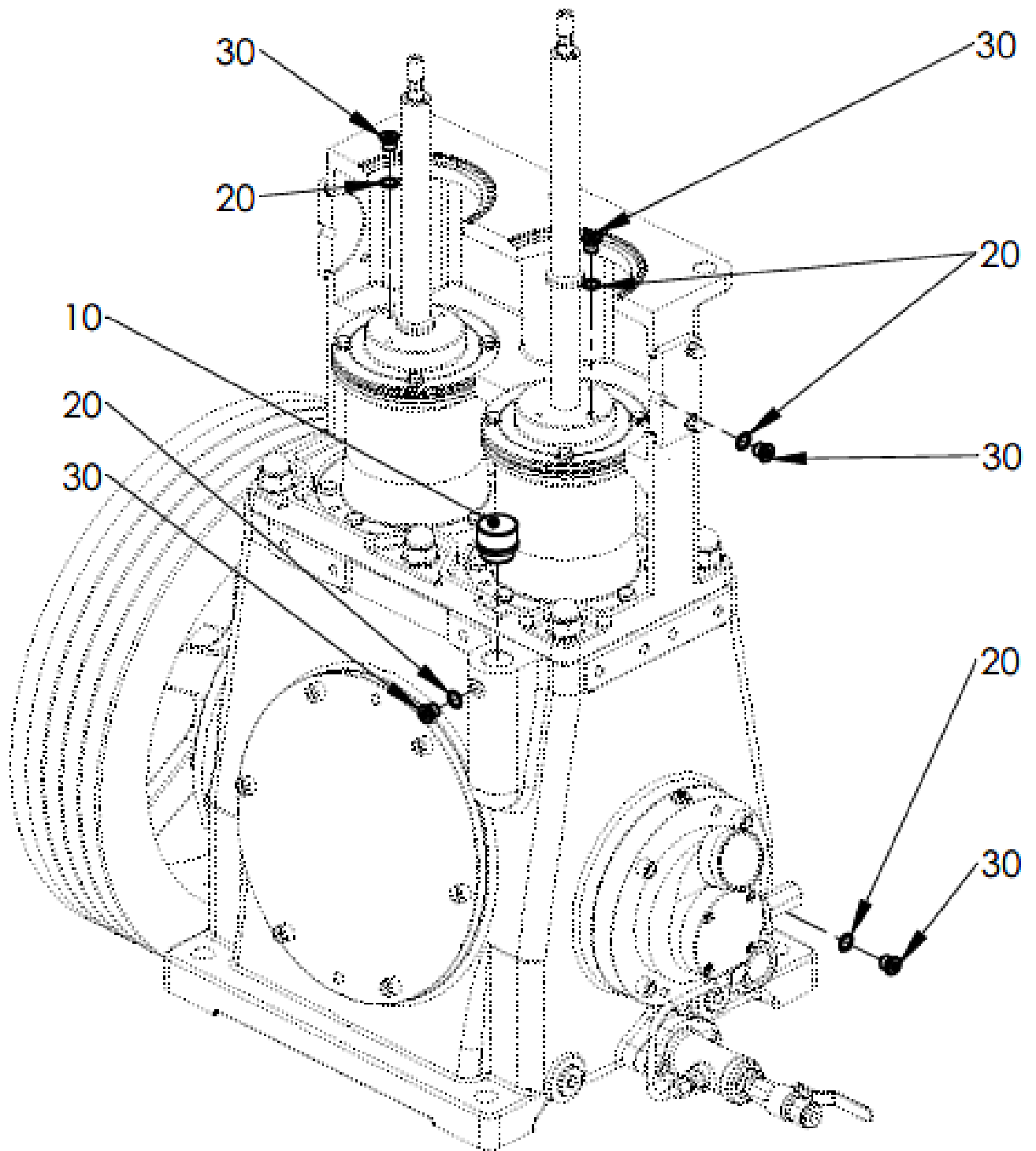

<b>ITEM</b>	<b>PART NO.</b>	<b>DESCRIPTION</b>	<b>QTY</b>
<b>TAG NO.</b>			
		<b>Drawing CC15028 Without purging gas</b>	
10	17811-CC1729	Vent screw	1
20	17811-CC1730	Sealing ring	5
30	17811-CC1731	Screw plug	5

# Drawing CC15029 Cooling water connection

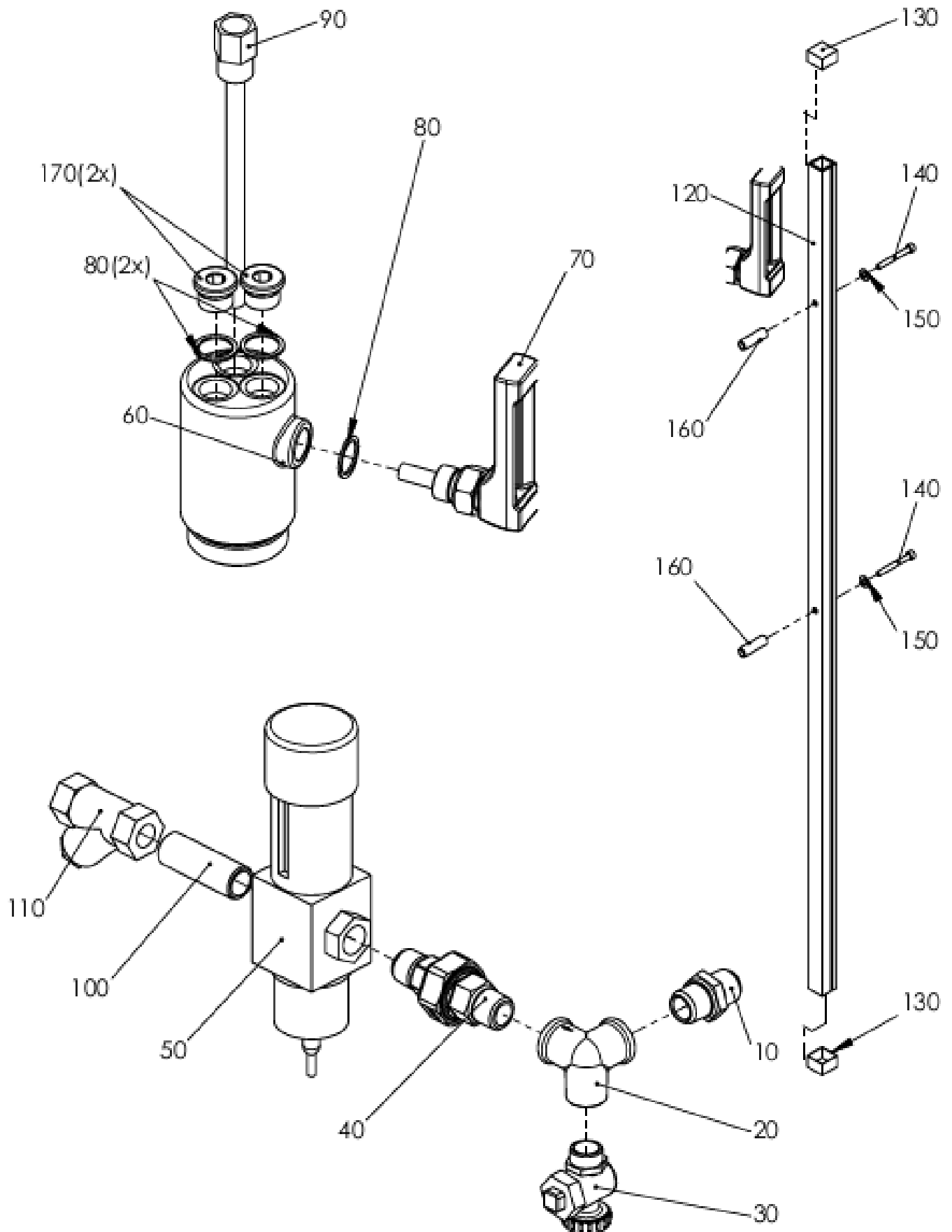

<b>ITEM</b>	<b>PART NO.</b>	<b>DESCRIPTION</b>	<b>QTY</b>
<b>TAG NO.</b>			
		<b>Drawing CC15029 Cooling water connection</b>	
10	17811-CC1732	Nipple	1
20	17811-CC1733	Angular distributor	1
30	17811-CC1734	Drain valve	1
40	17811-CC1735	Threaded joint	1
50	17811-CC1736	Thermostatic valve	1
60	17811-CC1737	Distributor	1
70	17811-CC1738	Thermometer	1
80	17811-CC1739	Sealing ring	3
90	17811-CC1740	Protective tube	1
100	17811-CC1741	Nipple	1
110	17811-CC1742	Strainer	1
120	17811-CC1743	Cable channel	0,8
130	17811-CC1744	Guard ring	2
140	17811-CC1745	Hexagon socket h.c. screw	2
150	17811-CC1746	Washer	2
160	17811-CC1747	Bush	2
170	17811-CC1748	Plug	2

<b>ITEM</b>	<b>PART NO.</b>	<b>DESCRIPTION</b>	<b>QTY</b>
<b>TAG NO.</b>			
	17811-C1749	Suction valve	1
	17811-C1750	Delivery valve	1

<b>ITEM</b>	<b>PART NO.</b>	<b>DESCRIPTION</b>	<b>QTY</b>
<b>TAG NO.</b>			
	17811-C1751	Seal kit oil change	1
	17811-C1752	Gasket	2
	17811-C1753	O-ring	1
	17811-C1754	O-ring	1
	17811-C1755	O-ring	1
	17811-C1756	Sealing ring	1
	17811-C1757	Oil 5 litre	1
	17811-C1758	Oil 1 litre	2

<b>ITEM</b>	<b>PART NO.</b>	<b>DESCRIPTION</b>	<b>QTY</b>
<b>TAG NO.</b>			
	17811-C0802	oil heater	1
	17811-C0802A	oil heater thermostat	1
20-AEC-7080-1	17811-C0003	After cooler	1

<b>ITEM</b>	<b>PART NO.</b>	<b>DESCRIPTION</b>	<b>QTY</b>
<b>TAG NO.</b>			
20-C-7080-M	17811-M0001	Main motor	1
	17811-M0002A	Motor bearing drive end	1
	17811-M0002B	Motor bearing non- drive end	1
	17811-M0002C	cooling fan	1
	17811-M0002D	terminal block	1

<b>ITEM</b>	<b>PART NO.</b>	<b>DESCRIPTION</b>	<b>QTY</b>
<b>TAG NO.</b>			
VT-71101	17811-S0601	Vibration Transmitter	1
FT-71101	17811-S0501	Flowmeter 1 1/2"	1
PIT-71103 PIT-71107	17811-S0800	Pressure transmitter	2
PIT-71104	17811-S0801	Pressure transmitter	1
TIT-71101 TIT-71102	17811-S0802	Temperature Transmitter	2
PDG-71101	17811-G0006	Differential pressure gauge	1
PG-71102	17811-G0007	Pressure Gauge	1
PG-71105	17811-G0008	Pressure Gauge	1
PG-71106	17811-G0009	Pressure Gauge	1
TG-71103 TG-71104	17811-G0010	Temperature Gauge	2
inlet package	17811-F0101	Y-strainer	1
water circuitn inle	17811-F0102	Y-strainer	1
TW-71101 TW-71102 TW-71103 TW-71104	17811-S0705	Thermowell	4
TE-71101 TE-71102	17811-S0706	Temperature Assembly	2
package inlet	17811-V0007	Hand Ball Valve 2" 150#	1
package outlet	17811-V0008	Hand Ball Valve 2" 300#	1
water inlet/outlet	17811-V0009	Hand Ball Valve 1 1/2" 150#	2

<b>ITEM</b>	<b>PART NO.</b>	<b>DESCRIPTION</b>	<b>QTY</b>
<b>TAG NO.</b>			
instrument take o	17811-V0010	Hand Ball Valve 1/2" 800#	2
instrument take o	17811-V0011	Hand Ball Valve 1/2" 800#	9
XV-71102	17811-V0012	Pneumatic Actuated Valve 1 1/2" 150#	1
water cooler regu	17811-V0013	Globe Valve 1 1/2" 150#	1
compressor outle	17811-V0202	Check Valve 2"	2
water inlet	17811-V0203	Check Valve 1 1/2"	1
PSV-71101	17811-V0303	Pressure Safety Valve	1
PSV-71102	17811-V0304	Pressure Safety Valve	1
No tag	17811-V0503	5-way Manifold	1
No tag	17811-V0504	2-way Manifold. Lockable	1
No tag	17811-V0505	2-way Manifold	5
XY-71101	17811-V0601	Solenoid Valve	2
XY-71102			
instrument air	17811-V0802	Pressure Reducing Valve	1
PV-71101	17811-V0803	Pressure Control Valve	1

<b>ITEM</b>	<b>PART NO.</b>	<b>DESCRIPTION</b>	<b>QTY</b>
<b>TAG NO.</b>			
		<b>UCP</b>	
2M14	17811-E0050	Panel Fan + Filter	1
2H19	17811-E0051	Power On Lamp	1
8A9	17811-E0052	HMI	1
25U12	17811-E0053	Hourmeter	1
25H4	17811-E0054	Operational Lamp (Green)	1
25H6	17811-E0055	Running Lamp (Green)	1
25H8	17811-E0056	Common Alarm Lamp (Amber)	1
25H10	17811-E0057	Common Trip Lamp (Red)	1
11S4	17811-E0058	Start Pushbutton (Green)	1
11S6	17811-E0059	Stop Pushbutton (Red)	1
11S8	17811-E0060	Accept Pushbutton (Black)	1
11S10	17811-E0061	Reset Pushbutton (Black)	1
11S12	17811-E0062	Lamp Test Pushbutton (Black)	1
3S6	17811-E0063	ESD Pushbutton	1
2S2	17811-E0064	Maintenance Switches	3
2S4			
2S6			
2F11	17811-E0065	Dual Pole Circuit Breaker, 230VAC, 2A	1
2F9	17811-E0066	Dual Pole Circuit Breaker, 230VAC, 6A	1
2F15	17811-E0067	Dual Pole Circuit Breaker, 110VAC, 10A	2
2F17			
2TH11	17811-E0068	Thermostats	2
2TH14			
2V15	17811-E0069	Power Supplies, 110VAC/24VDC, 20A	2
2v17			
2U13	17811-E0070	Panel Heater	1
5M2	17811-E0071	S7-400 Power Supply	2
5M11			
5M3	17811-E0072	S7-400 Central Processing Unit	2
5M12			
5M5	17811-E0073	CP 443-1 Communication Module	2
5M14			
5M18	17811-E0074	Ethernet Switch	1
58U5	17811-E0075	PID Controller	1
6M2	17811-E0076	ET200M Interface IM153-2HF	4
6M4			
7M2			
7M4			
6M7	17811-E0077	24 Digital Input Module	4
6M9			
7M7			

<b>ITEM</b>	<b>PART NO.</b>	<b>DESCRIPTION</b>	<b>QTY</b>
<b>TAG NO.</b>			
7M9			
6M10	17811-E0078	6 Analog Input Module	6
6M12			
6M14			
7M10			
7M12			
7M14			
6M15	17811-E0079	10 Digital Output Module	8
6M16			
6M18			
6M19			
7M15			
7M16			
7M18			
7M19			
9V4	17811-E0080	Diode Blocks	48
9V4.1			
24V4			
24V6			
25V4			
25V6			
25V8			
25V10			
25V12			
26V4			
26V6			
26V8			
26V10			
26V12			
27V4			
27V6			
27V8			
28V4			
28V6			
28V8			
28V10			
28V12			
30V4			
30V6			
30V10			
47V4			
47V6			

<b>ITEM</b>	<b>PART NO.</b>	<b>DESCRIPTION</b>	<b>QTY</b>
<b>TAG NO.</b>			
48V4			
48V6			
48V8			
48V10			
48V12			
49V4			
49V6			
49V8			
49V10			
49V12			
50V4			
50V6			
50V8			
51V4			
51V6			
51V8			
51V10			
51V12			
53V4			
53V6			
53V10			
28K3	17811-E0081	Interface Relays	18
28K5			
28K8			
28K10			
28K12			
30K4			
30K6			
30K10			
56K4			
56K6			
56K8			
56K10			
56K13			
56K15			
56K17			
57K12			
57K17			
58K9			
57K8	17811-E0082	ESD Relays, Single Pole	2
57K10			
24K4	17811-E0083	ESD Relays, Dual Pole	3

<b>ITEM</b>	<b>PART NO.</b>	<b>DESCRIPTION</b>	<b>QTY</b>
<b>TAG NO.</b>			
24K6			
27K8			
9U4	17811-E0084	Loop Splitters	11
9U5			
9U6			
9U6.1			
9U7			
9U8			
9U9			
9U10			
9U11			
9U12			
9U13			
5F2	17811-E0085	Dual Pole Circuit Breaker, 24VDC, 6A	2
5F11			
2F15.1	17811-E0086	Single Pole Circuit Breaker, 24VDC, 20A	2
2F17.1			
2G15	17811-E0087	Quint Diode	1
2H10	17811-E0088	Panel Light	1

<b>ITEM</b>	<b>PART NO.</b>	<b>DESCRIPTION</b>	<b>QTY</b>
<b>TAG NO.</b>			
		<b>LCP</b>	
3H4	17811-E0089	Operational lamp (green)	1
3H6	17811-E0090	Running lamp (green)	1
3H8	17811-E0091	Common alarm lamp (amber)	1
3H10	17811-E0092	Common trip lamp (red)	1
2S4	17811-E0093	Start pushbutton (green)	1
2S6	17811-E0094	Stop pushbutton (red)	1
2S8	17811-E0095	Lamptest pushbutton (black)	1
2S10	17811-E0096	Selector switch (local/off/remote)	1
4S3	17811-E0097	ESD button	1

# Bushehr MEG Plant Project

<b>VENDOR NAME</b>	: Airpack Nederland B.V
<b>EQUIPMENT DESCRIPTION</b>	: Nitrogen & Instrument Booster Package
<b>EQUIPMENT TAGNUMBER</b>	: 20-C-1002, 20-C-7080

## SECTION 23

### TROUBLESHOOTING



Vendor doc. Number

17811-20

Vendor:

Airpack Nederland B.V.

P.O. NO.:

MEG20-PO-BP303-021

SHEET QTY: 03



## Table of Contents

23 Troubleshooting .....3

## 23 Troubleshooting

See sections 2 and 3.

# Bushehr MEG Plant Project

VENDOR NAME	: Airpack Nederland B.V
EQUIPMENT DESCRIPTION	: Nitrogen & Instrument Booster Package
EQUIPMENT TAGNUMBER	: 20-C-1002, 20-C-7080

## SECTION 24

### PREVENTIVE MAINTENANCE CHART



Vendor doc. Number

17811-20

Vendor:

Airpack Nederland B.V.

P.O. NO.:

MEG20-PO-BP303-021

SHEET QTY: 03



Please refer to section 2 and 3 for details about the compressor itself.

	Maintenance intervals in operating hours <sup>1)</sup>					
	DAILY	500 MONTHLY	1500 3 MONTHLY	3000 6 MONTHLY	5000 YEARLY	10000 TWO YEARLY
<b>GENERAL MAINTENANCE WORK</b>						
Keep the package clean	•					
Check all connections are securely fixed		•				
Check overall condition of the system		•				
<b>ELECTRICAL / INSTRUMENTS</b>						
Tighten electrical terminals			•			
Check pressure gauge and temperature indicator are working		•				
Check thermo elements for damage/bends		•				
Calibration of all transmitters including analysers				•	•	
Change solenoid coil						•
Spare kit for Control valve and actuators						•
Check complete electric control unit						•
<b>COMPRESSOR</b>						
Check all connections are securely fixed		•				
Check overall condition of the system	•					
Check the lubrication oil level and replenish as necessary	•					
Check the air filter pressure differential	•					
Check the condensate drain functionality	•					
Change the oil filter element		• <sup>(1)</sup>				
Clean the condensate strainers		•				
Check the cooler(s) for build-up of foreign matter. Clean if necessary by blowing out with air		•				



BUSHEHR MEG PLANT PROJECT

Rev.: 00  
Date: 08-11-2024

Preventive maintenance chart

	Maintenance intervals in operating hours <sup>(1)</sup>						
	DAILY	500 MONTHLY	1500 3 MONTHLY	3000 6 MONTHLY	5000 YEARLY	10000 TWO YEARLY	
Operate the safety valves manually to verify that the valve mechanism is functioning correctly and that a small amount of air is released.			•				
Check all hoses for sign if deterioration, cracks, hardening etc.			•				
Lubricate the main motor drive end bearing. Lubricate the main motor non-drive end bearing.				•			
Inspect the blowdown silencers and replace if necessary. Clean the gear case breathers				•			
Check the calibration of the pressure transducers. Change the air filter element (replace more frequently if local condition require)				•			
Fully inspect condensate separators, all external surfaces, and fittings. Report any excessive corrosion, mechanical or impact damage, leakage or other deterioration					•		
Rebuild blowdown valve using field kit					•		
Inspect the starter contactors, replace if required.					•		
Clean the condensate strainers.					•		
Change the lubricating oil and filter element.					•		
Remove the safety valves from compressor, inspect and re-calibrate					•		

NOTE:

(1) Only first time.

# Bushehr MEG Plant Project

<b>VENDOR NAME</b>	: Airpack Nederland B.V
<b>EQUIPMENT DESCRIPTION</b>	: Nitrogen & Instrument Booster Package
<b>EQUIPMENT TAGNUMBER</b>	: 20-C-1002, 20-C-7080

## SECTION 25

### LOGBOOK



Vendor doc. Number

17811-20

Vendor:

Airpack Nederland B.V.

P.O. NO.:

MEG20-PO-BP303-021

SHEET QTY: 03



### Logbook

Customer : Bushehr Petrochemical Company (BUPC)  
Contractor : FGS  
Agent : HSE Group  
Purchase order number : MEG20-PO-BP303-021  
Airpack reference : 17811-COM  
Serial number : T-2020-00753/00754  
Page : 1

Each plant operator shall duly enter all maintenance and service work that has been carried out, and shall see that the person responsible confirms such work by signing below.

MAINTENANCE WORK	DATE	SIGNATURE PLANT OPERATOR	CONFIRMED BY RESPONSIBLE PERSON



### Logbook

Customer : Bushehr Petrochemical Company (BUPC)  
Contractor : FGS  
Agent : HSE Group  
Purchase order number : MEG20-PO-BP303-021  
Airpack reference : 17811-COM  
Serial number : T-2020-00753/00754  
Page : 2

Each plant operator shall duly enter all maintenance and service work that has been carried out, and shall see that the person responsible confirms such work by signing below.

MAINTENANCE WORK	DATE	SIGNATURE PLANT OPERATOR	CONFIRMED BY RESPONSIBLE PERSON

# Bushehr MEG Plant Project

<b>VENDOR NAME</b>	: Airpack Nederland B.V
<b>EQUIPMENT DESCRIPTION</b>	: Nitrogen & Instrument Booster Package
<b>EQUIPMENT TAGNUMBER</b>	: 20-C-1002, 20-C-7080

## SECTION 26

### PLANT MANAGER LIABILITY LIST



**Vendor doc. Number**

17811-20

**Vendor:**

Airpack Nederland B.V.

**P.O. NO.:**

MEG20-PO-BP303-021

**SHEET QTY: 03**



