

OWNER:



**BUSHEHR PETROCHEMICAL COMPANY  
MEG PLANT**

EPC CONTRACTOR:



## Architecture diagram for reciprocating compressor

MC :



شرکت سبت و سولی  
توسعه ایرانیان





Owner Document Number:  
17811-46

Project	Area	Phase	Unit	Dis.	Doc.	Seq.	Contract No : 52-98/445	
BU	20	VD	303	IN	DIG	0044	Rev.:	Page
							00	1 of 3

نقشه باید مطابق با فرمت پروژه باشد

## Architecture diagram for reciprocating compressor

00	12/03/2021	For approval	TJ	KP	PW		
Rev.	Date	Purpose of Issue	Prepared	Checked	Approved	AC Code	
							Class: 1 Phase: 1p

OWNER  شرکت پتروشیمی بوتهر	<b>BUSHEHR PETROCHEMICAL COMPANY MEG PLANT</b>							EPC CONTRACTOR: 	
	<b>Architecture diagram for reciprocating compressor</b>								
MC :  شرکت سفت و سوی توسعه ایرانیان	Project	Area	Phase	Unit	Dis.	Doc.	Seq.	Contract No : 52-98/445	
<b>Owner Document Number: 17811-46</b>	BU	20	VD	303	IN	DIG	0044	Rev.:	Page
								00	2 of 3

### TABULATION OF REVISED PAGES

Page	D00	D01	D02	D03	D04
1.	X				
2.	X				
3.	X				
4.					
5.					
6.					
7.					
8.					
9.					
10.					
11.					
12.					
13.					
14.					
15.					
16.					
17.					
18.					
19.					
20.					
21.					
22.					
23.					
24.					
25.					
26.					
27.					
28.					
29.					
30.					
31.					
32.					
33.					
34.					

Page	D00	D01	D02	D03	D04
35.					
36.					
37.					
38.					
39.					
40.					
41.					
42.					
43.					
44.					
45.					
46.					
47.					
48.					
49.					
50.					
51.					
52.					
53.					
54.					
55.					
56.					
57.					
58.					
59.					
60.					
61.					
62.					
63.					
64.					
65.					
66.					
67.					
68.					

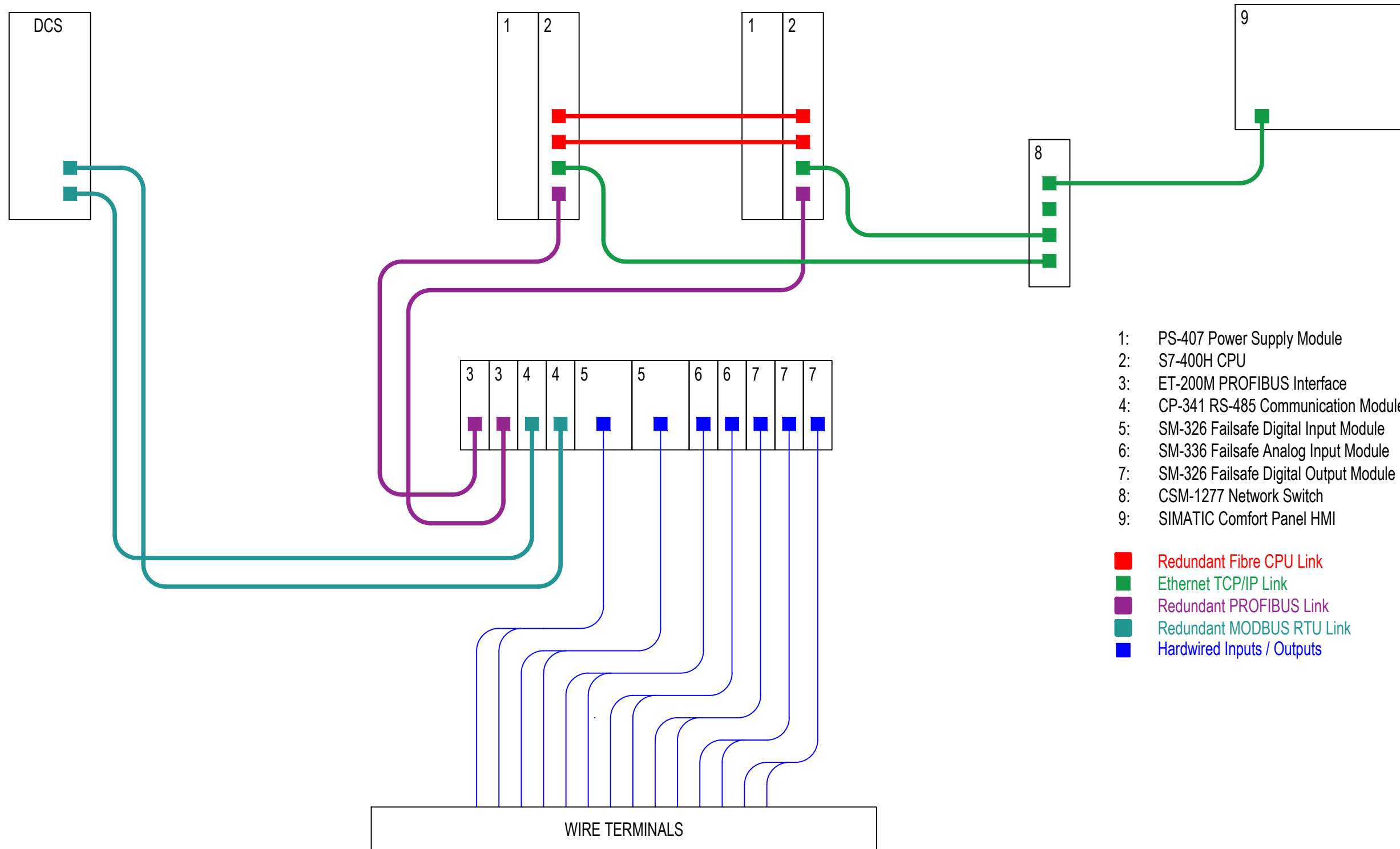

- 1: PS-407 Power Supply Module
- 2: S7-400H CPU
- 3: ET-200M PROFIBUS Interface
- 4: CP-341 RS-485 Communication Module
- 5: SM-326 Failsafe Digital Input Module
- 6: SM-336 Failsafe Analog Input Module
- 7: SM-326 Failsafe Digital Output Module
- 8: CSM-1277 Network Switch
- 9: SIMATIC Comfort Panel HMI

- Redundant Fibre CPU Link
- Ethernet TCP/IP Link
- Redundant PROFIBUS Link
- Redundant MODBUS RTU Link
- Hardwired Inputs / Outputs

NOTES:

	SUBJECT MEG PLANT NITROGEN COMPRESSOR PLC ARCHITECTURE DIAGRAM		DATE	11-03-2021	THIS DRAWING IS OWNED BY AIRPACK AND SHALL NOT BE PRINTED OR COPIED IN ANY OTHER WAY THAN WITH AIRPACKS PERMISSION
	CLIENT	BUSHEHER PETROCHEMICAL COMPANY (BUPC)	DRAWN BY	TJ	
CLIENT REF	MEG20-PO-BP303-021	CHECKED BY	KP	PLANT LOCATION	-
AIRPACK REF	17811-COM	DRAWING NO.	17811-46	SHEETNO.	01 / 01
			REV 00	11-03-2021	TJ