





OWNER:  شرکت سست و سویی توهمه ایران (سهامی خاص)	BUSHEHR PETROCHEMICAL COMPANY MEG PLANT						EPC CONTRACTOR:  Chagalesh-Enerchimi-Steam Joint Venture BUPC-MEG PLANT PROJECT		
	DATA SHEET & DRAWINGS FOR STRAINERS FOR EMERGENCY INSTRUMENT AIR COMPRESSOR								
MC :  شرکت سست و سویی توهمه ایران (سهامی خاص)	Project	Area	Phase	Unit	Dis.	Doc.	Seq.	Contract No : 52-98/445	
Owner Document Number: 17811-44B	BU	20	VD	303	ME	DSH	0082	Rev.:	Page
								02	1 of 6

DATA SHEET & DRAWINGS FOR STRAINERS FOR EMERGENCY INSTRUMENT AIR COMPRESSOR

Rev	Date	Purpose of Issue	Prepared	Checked	Approved	AC Code
02	14/12/2021	Approved for Construction	TvT	KP	LdM	
01	27/10/2021	Approved for Construction	TvT	KP	LdM	
00	25/02/2021	For approval	TvT	KP	LdM	
Class: 1 Phase: P						



INDEX			
No.	Device	Tag Number	Page
1	Y-Strainer	No Tag.No: Qty 1 pcs	4
2	Y-Strainer	No Tag.No: Qty 1 pcs	5
3	Y-Strainer Drawing	No Tag.No	6
4			
5			
6			
7			
8			
9			
10			
11			
12			
13			
14			
15			
16			
17			
18			
19			
20			
21			
22			
23			
24			
25			
26			
27			
28			
29			
30			
31			
32			
33			
34			
35			
36			
37			
38			
39			
40			
41			
42			
43			
44			
45			
46			
47			
48			
49			
50			
51			
52			
53			
54			
55			

Notes:

				DATA SHEET & DRAWINGS FOR STRAINERS FOR EMERGENCY INSTRUMENT AIR COMPRESSOR			
02	TT	14-12-2021	Approved for construction				
01	TT	27-10-2021	For Approval				
00	TT	20-9-2021	For Approval				
Rev	By	Date	Description			Sheet	3 of 6
						Based on P&ID	Rev.02

GENERAL	1	Tag Number		No Tag.No: Qty 1 pc	
	2	Service		Y-strainer	
	3	P&ID No.		17811-03	
	4	Location		Compressor Inlet	
	5				
	6				
	7				
	8				
PROCESS CONDITIONS	9	Fluid	State		Air Dry Gas
	10	Pressure	Norm.	Max.	8 Bar(a) 8,5 Bar(a)
	11	Temperature	Norm.	Max.	Ambient 45°C
	12	Design	Press.	Temp.	13.5 Bar(a) 80°C
	13	Ambient Temp.	Min.	Max.	5 °C 55 °C
	14	Oper. Flow		50 Kg/hr / 43 Nm3/hr	
	15				
	16				
BODY	20	Type Of Body		Y-strainer	
	21	Connection		2" ANSI RF 150#	
	22	Body Material		A216 WCB	
	23	Mesh Material		SS 316	
	24	Mesh Size		3 mm	
	25				
	26				
	27				
	28				
	29				
	30				
	31				
	32				
	33				
	34				
	35				
	36				
	CERTIFICATES	47	3.1 Material certificate		Yes
48					
49					
50					
51					
52					
PURCHASE	53	Manufacturer		Barton Firtop	
	54	Model		SDD/YLD/R150	
	55				
	56				
	57				

--	--	--	--

				Y-Strainer 	
02	TT	14-12-2021	Approved for construction		Sheet 4 of 6 Based on P&ID Rev.02
01	TT	27-10-2021	For Approval		
00	TT	20-9-2021	For Approval		
Rev	By	Date	Description		

GENERAL	1	Tag Number		No Tag.No: Qty 1 pc		
	2	Service		Y-strainer		
	3	P&ID No.		17811-03		
	4	Location		Compressor Cooling water inlet		
	5					
	6					
	7					
	8					
PROCESS CONDITIONS	9	Fluid	State		Water	Liquid
	10	Pressure	Norm.	Max.	4,5 Bar(g)	5 Bar(g)
	11	Temperature	Norm.	Max.	35°C	45°C
	12	Design	Press.	Temp.	6 Bar(g)	60°C
	13	Ambient Temp.	Min.	Max.	5 °C	55 °C
	14	Oper. Flow		3,5 m3/hr		
	15					
	16					
	17					
	18					
BODY	20	Type Of Body		Y-strainer		
	21	Connection		1 1/2" ANSI RF 150#		
	22	Body Material		A216 WCB		
	23	Mesh Material		SS 316		
	24	Mesh Size		3 mm		
	25					
	26					
	27					
	28					
	29					
	30					
	31					
	32					
	33					
	34					
	35					
	36					
	CERTIFICATES	47	3.1 Material certificate		Yes	
48						
49						
50						
51						
52						
PURCHASE	53	Manufacturer		Barton Firtop		
	54	Model		SDD/YLD/R150		
	55					
	56					
	57					

--	--	--	--

					
02	TT	14-12-2021	Approved for construction	Sheet 5 of 6 Based on P&ID Rev.02	
01	TT	27-10-2021	For Approval		
00	TT	20-9-2021	For Approval		
Rev	By	Date	Description		

R/F - 150LB RATING LIGHT DUTY 'Y'-TYPE STRAINER

Sizes: ½" to 12" Nominal Bore

Pressure: ASME Class 150LB

Features:

- Integrally Cast Housing.
- Bolted Cover c/w Drain Plug.
- Red oxide Finish (Carbon Steel).
- 3mm Perf. Screen as Standard.

Options:

- Special Gasket, Special Screen.
- D.P. Tappings/Gauge.
- Magnetic Screen Insert.
- Flanged Drains / Drain Valves.
- Special Finish / Linings.

Standards: PED 2014/68/EU.
ASME B16.5 Flange Dimensions.
EN 10204 / NACE Certification.
Generally i.a.w. ASME VIII, Div. 1

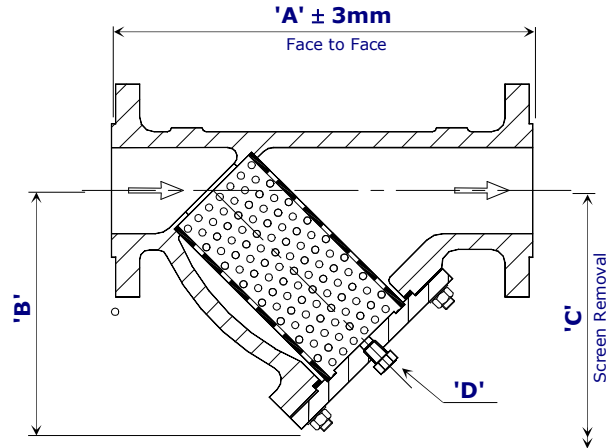

Size		Dimensions				Screen Area (cm ²)	Weight (KG)
		'A' Face to Face	'B' Base to Centre line	'C' Screen Removal	'D' Drain (NPT)		
Inch	mm						
½"	15	170.0	95.0	165.0	½"	80.0	3.0
¾"	20	170.0	95.0	165.0	½"	80.0	4.0
1"	25	185.0	110.0	185.0	½"	126.5	6.0
1½"	40	270.0	140.0	230.0	½"	199.0	10.5
2"	50	275.0	180.0	285.0	½"	333.0	17.0
2½"	65	360.0	220.0	355.0	½"	574.5	27.5
3"	80	360.0	220.0	355.0	½"	574.5	29.5
4"	100	435.0	260.0	410.0	½"	923.4	49.0
6"	150	560.0	340.0	552.0	½"	1894.0	97.0
8"	200	655.0	440.0	705.0	¾"	2870.0	180.0
10"	250	880.0	600.0	1000.0	¾"	5000.0	340.0
12"	300	970.0	640.0	1040.0	¾"	6375.0	510.0