







OWNER:  شرکت سست و سویی توهمه ایران (سهامی خاص)	BUSHEHR PETROCHEMICAL COMPANY MEG PLANT						EPC CONTRACTOR:  Chagalesh-Enerchimi-Steam Joint Venture BUPC-MEG PLANT PROJECT		
	LUBE OIL SYSTEM HEATER DATA SHEET AND DRAWING FOR NITROGEN GAS BOOSTER						 Netherlands		
MC :  شرکت سست و سویی توهمه ایران (سهامی خاص)	Project	Area	Phase	Unit	Dis.	Doc.	Seq.	Contract No : 52-98/445	
Owner Document Number: 17811-11D	BU	20	VD	303	EL	DWG	0021	Rev.:	Page
								01	1 of 3

LUBE OIL SYSTEM HEATER DATA SHEET AND DRAWING FOR NITROGEN GAS BOOSTER

01	16/12/2021	For approval		KP	LdM	CL	
00	18/11/2021	For approval		KP	LdM	CL	
Rev.	Date	Purpose of Issue		Prepared	Checked	Approved	AC Code
						Class: 1	Phase: P

VENDOR 	LUBE OIL SYSTEM HEATER DATA SHEET AND DRAWING FOR EMERGENCY INSTRUMENT AIR COMPRESSOR	P.O. No.	52-98/445
		Document No.	17811-1D
		Sheet No.	3
		Rev.No	01
CONTRACTOR / END USER 	BUSHEHR PETROCHEMICAL COMPANY MEG PLANT		
		Service	instrument air compressor 20-C-7080

1	OIL HEATER (20-C-7080-EC)	
2	No. Required	1
3	MFR Supplier	Elmess
4	Type of heater:	Immersion /cartridge
5	Oil Type (Pumping Fluid) :	Klüber Summit PS300
6	Power	75W
7	Voltage	230 VAC
8	Phases	1
9	Frequency	50 / 60
10	Heater Control	PT-100, controlled by external thermostat
11	Length (L)	300 mm
12	Diameter (D)	15 mm
13	Hazerdous area	II 2G Ex db eb IIC T3 Gb
14	Protection class	IP 66
15	Duty	Standby
16	Power Factor	1
17	Efficiency	100%
18	Cable entry	2 x M20 X 1.5
19		

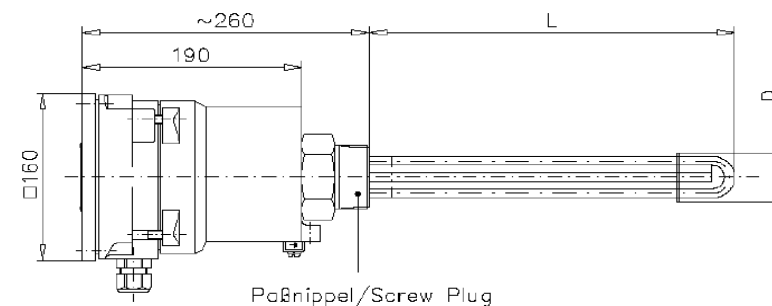

Paßnippel/Screw Plug