





OWNER:  شرکت سست و سویی گیس ایرپک ایران (سهامی عامه)	BUSHEHR PETROCHEMICAL COMPANY MEG PLANT							EPC CONTRACTOR:  Chagalesh-Enerchimi-Steam Joint Venture BUPC-MEG PLANT PROJECT	
	PULSATION DAMPER DETAIL DRAWING FOR NITROGEN GAS BOOSTER								
MC :  شرکت سست و سویی گیس ایرپک ایران (سهامی عامه)	Project	Area	Phase	Unit	Dis.	Doc.	Seq.	Contract No : 52-98/445	
Owner Document Number: 17811-23C	BU	20	VD	303	ME	DWG	0079	Rev.:	Page
								05	1 of 6

PULSATION DAMPER DETAIL DRAWING FOR NITROGEN GAS BOOSTER

05	16/06/2022	For approval	KP	CL	JR	
04	03/06/2022	For approval	KP	CL	JR	
03	13/05/2022	For approval	KP	CL	JR	
02	06/05/2022	For approval	KP	CL	JR	
01	26/04/2022	For approval	KP	CL	JR	
00	06/04/2022	For approval	KP	CL	JR	
Rev.	Date	Purpose of Issue	Prepared	Checked	Approved	AC Code
					Class: 1	Phase: P

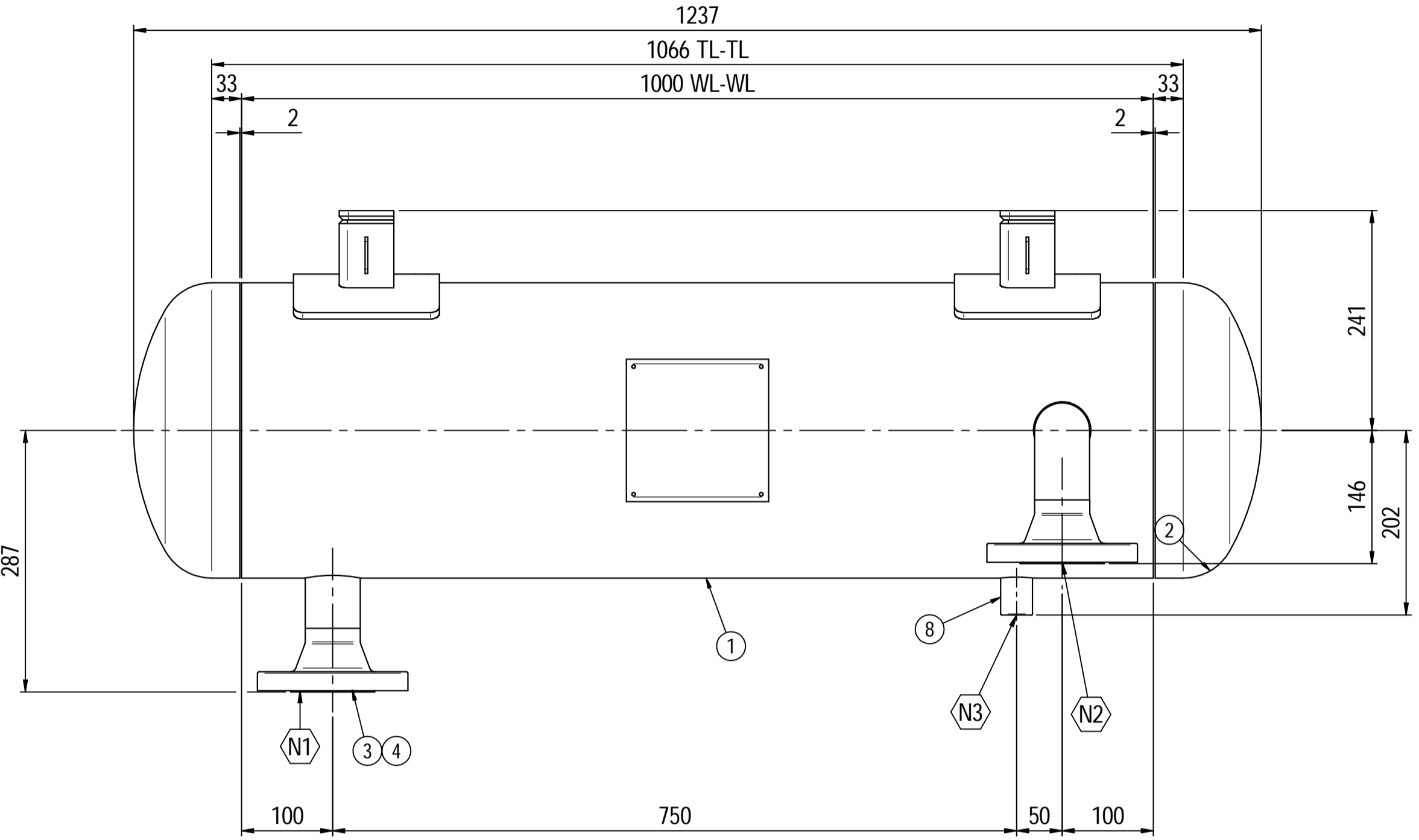
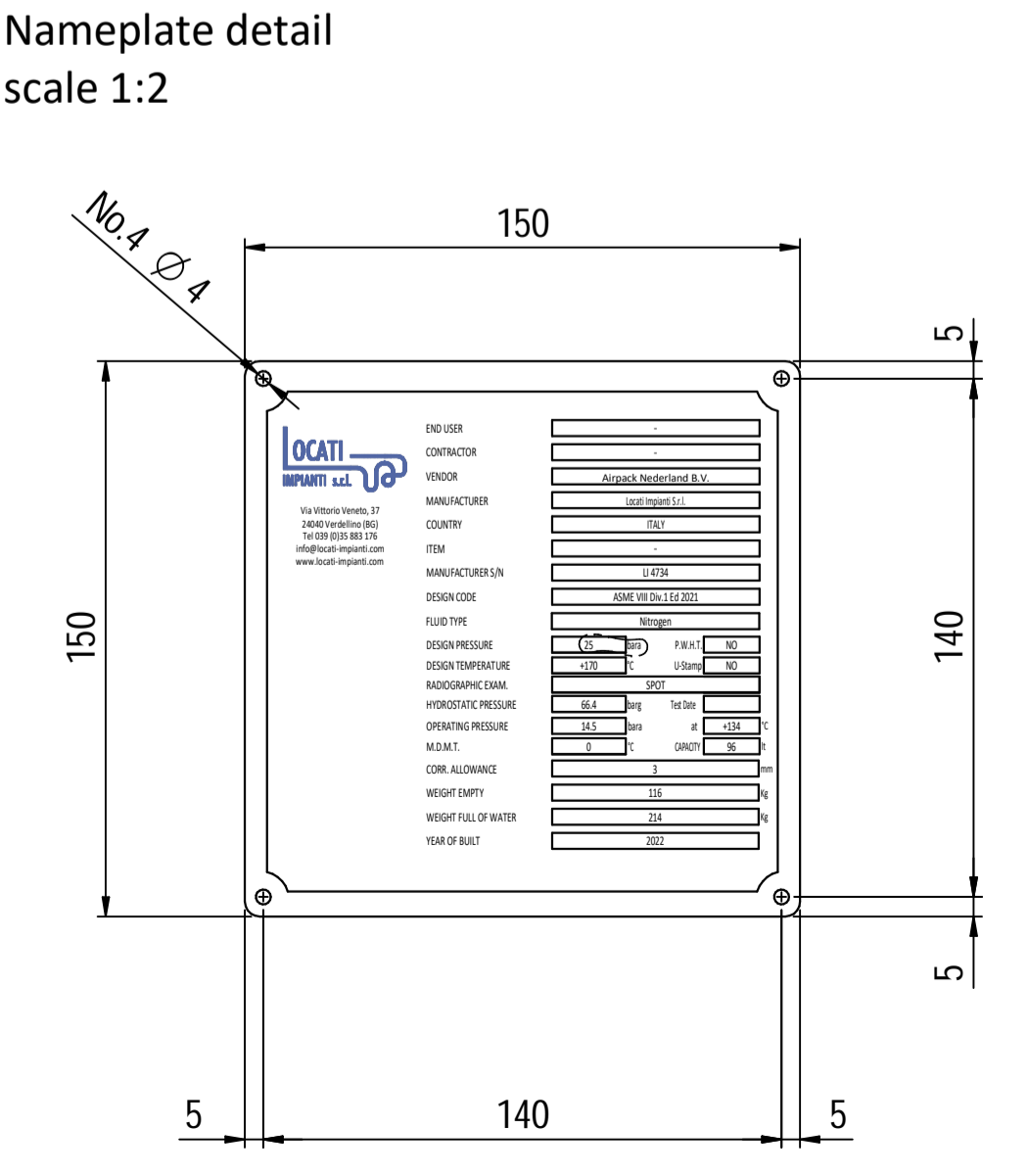
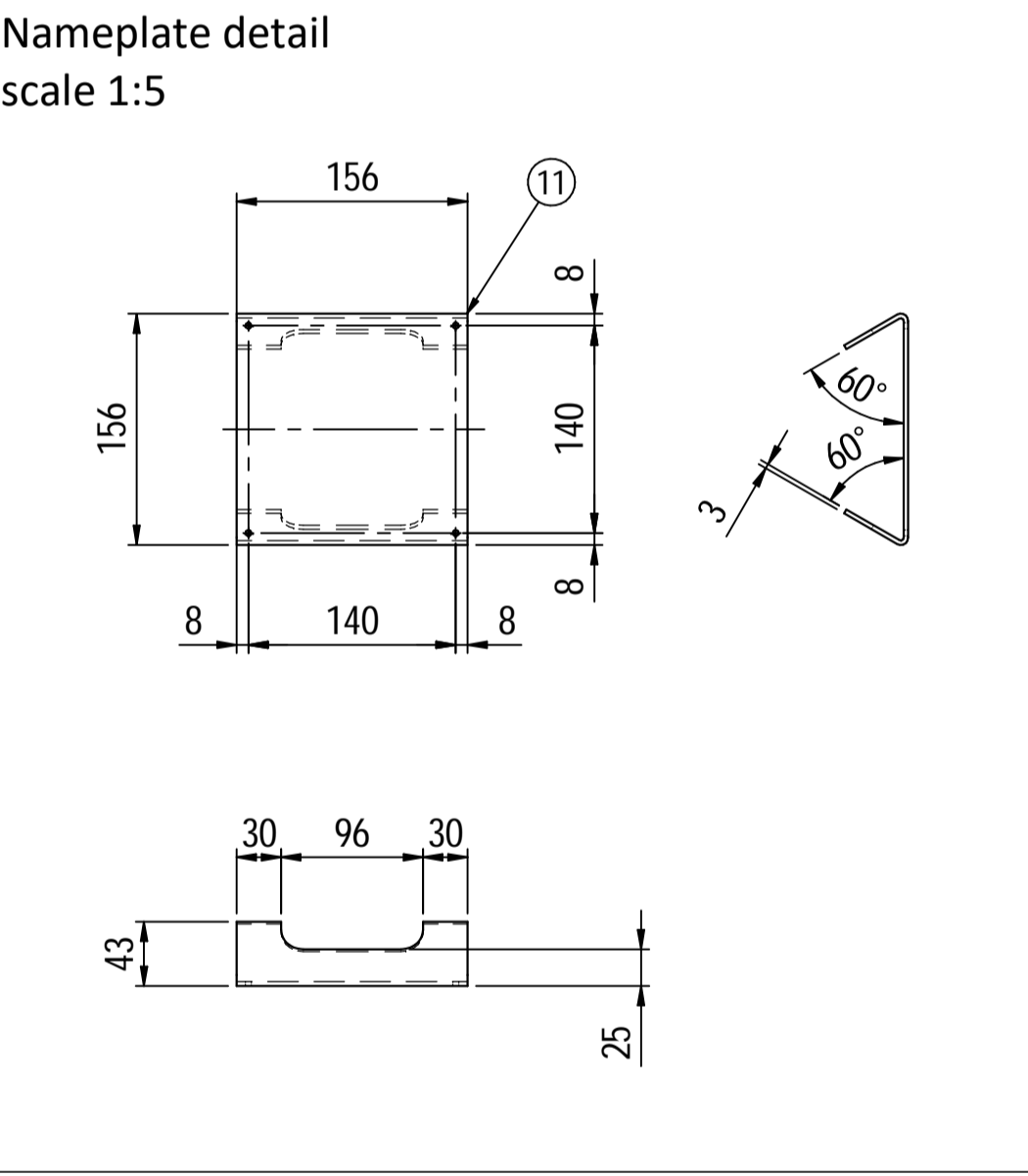
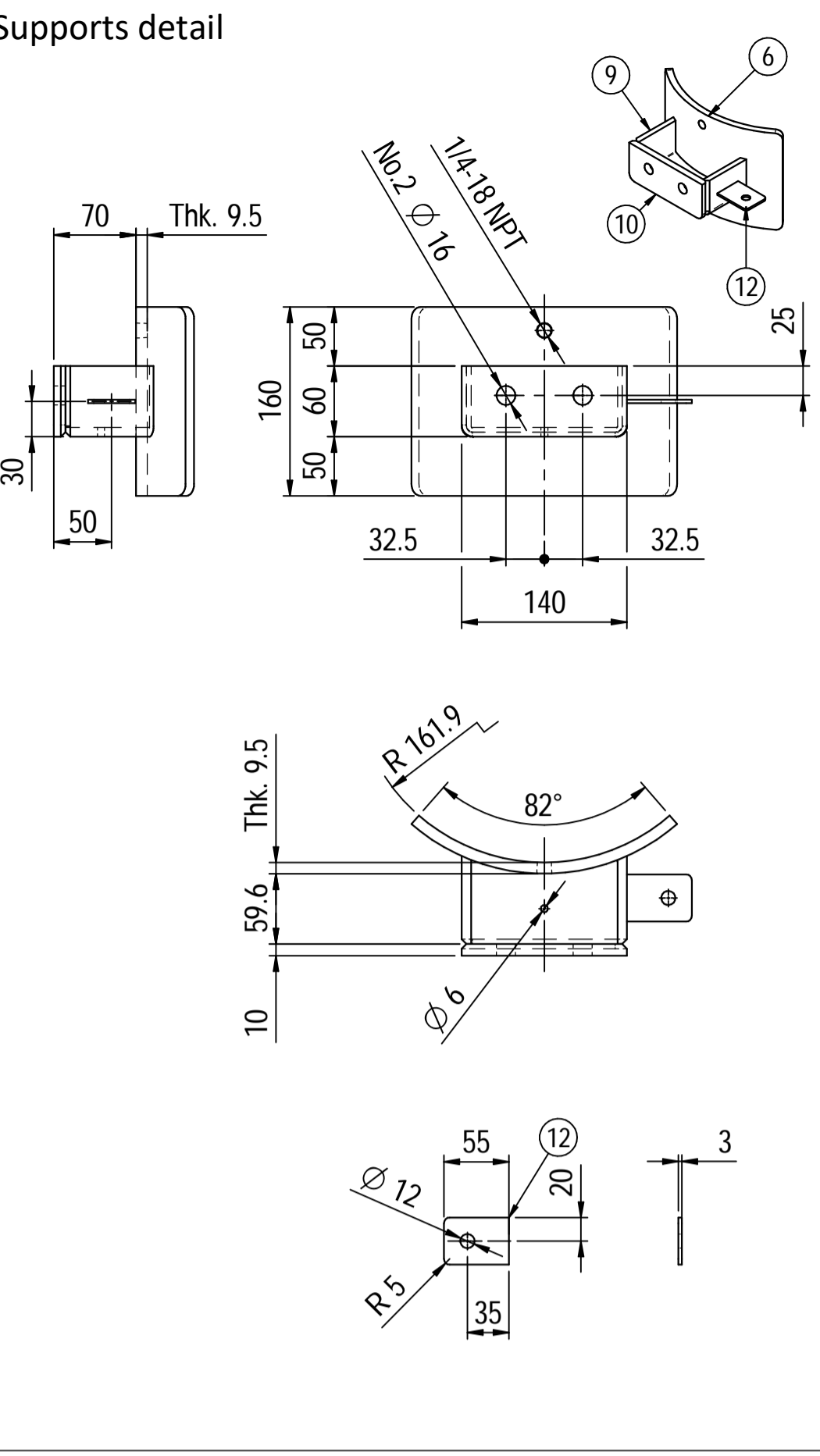

ELEVATION VIEW

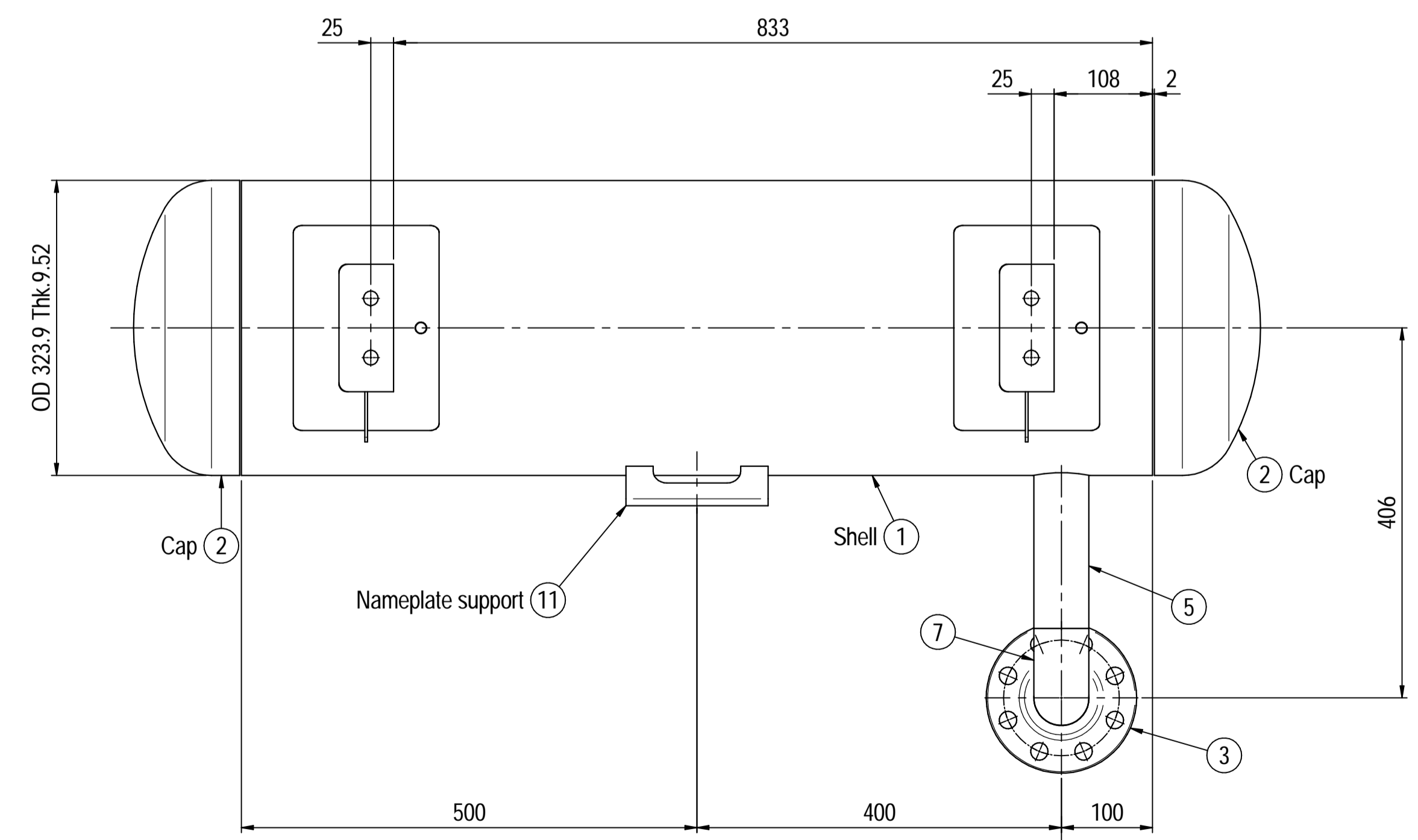

PLAN VIEW

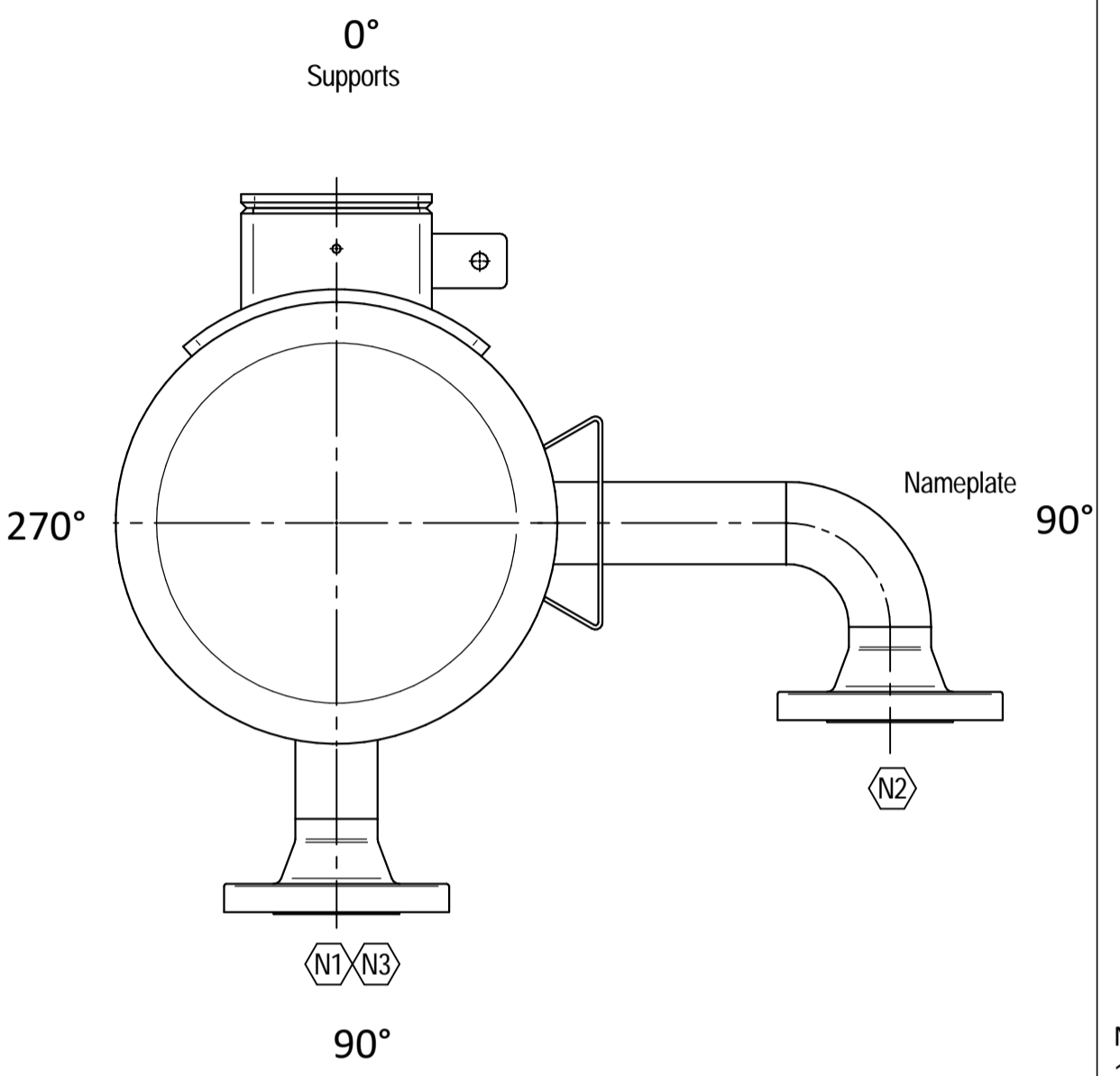

ORIENTATION VIEW

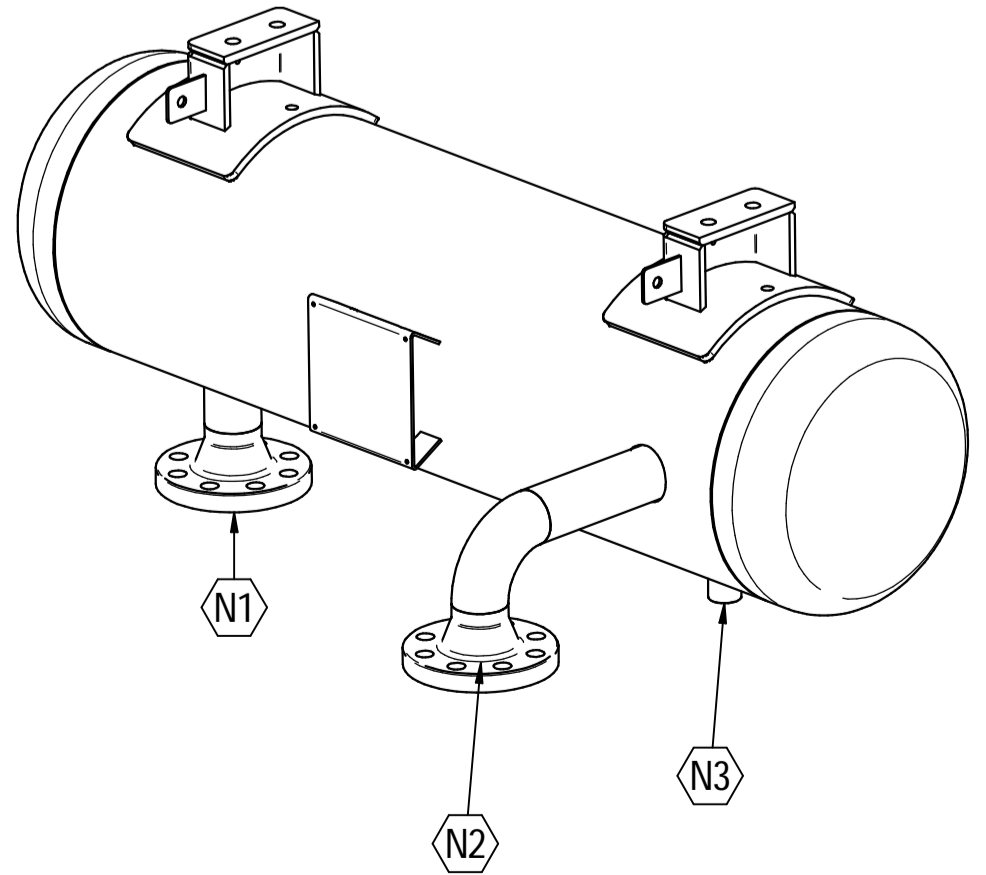

ISOMETRIC VIEW scale 1:8

Material List				
Pos.	Q.ty	Description	Mat.	Cert.
1	1	Shell by pipe 12" Sch.STD L=1000	SA106 Gr.B	3.1
2	2	Reduced cap 12" Sch.STD	SA234 WPB	3.1
3	2	Flange 2" WN #300 RF Sch.160	A105	3.1
4	1	Seamless pipe 2" Sch.160	A106 GrB	3.1
5	1	Seamless pipe 2" Sch.160	A106 GrB	3.1
6	2	Pad by pipe 12" Sch.STD	A106 Gr.B	3.1
7	1	Seamless elbow 2" 90° LR Sch.160	A234 WPB	3.1
8	1	Coupling 1/2" NPT #6000	A105	3.1
9	2	Plate 74.5x231 Thk.8	A516 70	3.1
10	2	Plate 16x65 Thk.10	A516 70	3.1
11	1	Nameplate support 156x241 Thk.3mm	A516 70	3.1
12	2	Earthing Plate 55 x 40 Thk.3	A240 TP316L	

- Note:
- 1) Governing measurement S.I. unless otherwise specified;
 - 2) Flange bolt holes have to be straddled from main vessel center line in plan & vertical & horizontal centreline in elevation;
 - 3) Material: certification 3.1 EN 10204;
 - 4) All internal edge shall be rounded off;
 - 5) Nozzle flanges in accordance with ASME B16.5: 2013;
 - 6) Flange fittings in accordance with ASME B16.9: 2012;
 - 7) The flange dimensions are in accordance to ASME B16.5: 2013;
 - 8) All fillet welds not detailed on "WELDING MAP" or drawing shall have the weld; throated equal to 0,7 times the minimum thickness to be welded;
 - 9) All welds are continuous except where indicate;
 - 10) See document C220006CLC010 for vessel calculation.

ITEM	QTY	SERVICE	SIZE	PIPE O.D.	THK	RATING	FLANGE TYPE	FACE	O.D.	THK.	Tc
N3	1	DRAIN	1/2"	38.1	8.38	#6000	-	NPT-F	-	-	8.5 ± 10
N2	1	AIR OUTLET	2"	60.3	8.74	#300	WN	RF	-	-	8.5 ± 10
N1	1	AIR INLET	2"	60.3	8.74	#300	WN	RF	-	-	8.5 ± 10

DATI DI PROGETTO / Design data			
FLUIDO	Nitrogen	COLLAUDO	Test
STATO FISICO DEL FLUIDO	Gas	NATIONAL BOARD REGISTRATION	NO
Physical state of fluid	Gas	NATIONAL BOARD REGISTRATION	NO
CODICE DI CALCOLO	ASME VIII Div. 1 Ed.2021	CANADIAN REGISTER NUMBER	NO
Construction code	ASME VIII Div. 1 Ed.2021	CANADIAN REGISTER NUMBER	NO
PRESIONE DI ESERCIZIO	14.5 bara	SERVIZIO LETALE	NO
Operating pressure	14.5 bara	Letal service	NO
PRESIONE DI PROGETTO	25 bara (24 barg)	R-RAY	RT examination
Design pressure	25 bara (24 barg)	R-RAY	RT examination
PRESIONE ESTERNA	NO	LICUIDI PENETRANTI	NO
External pressure	NO	Dye penetrant extension	NO
PRESIONE DI PROVA IDRAULICA	66.4 barg	ULTRASUONI	NO
Hydraulic test pressure	66.4 barg	Ultrasonic extension	NO
TEMPERATURA DI ESERCIZIO	+134 °C	CONTROLLO MAGNETOSCOPICO	NO
Operating temperature	+134 °C	Magnetic particle examination	NO
TEMPERATURA DI PROGETTO	+170 °C	TALONE DI SALDATURA	NO
Design temperature	+170 °C	Weld teels coupon	NO
SOVRAMETALLO DI CORROSIONE	3 mm	PROCEDIMENTO DI SALDATURA	See doc:C220006WBK013
Corrosion allowance	3 mm	Welding procedure	See doc:C220006WBK013
CAPACITA'	96 l	TIPO DI FONDO	CAP
Capacity	96 l	Head type	CAP
EFFICIENZA GIUNTI	0.85	FORMAZIONE FONDO	HOT
Joint efficiency	0.85	Head formed	HOT
MAWP @ Design Temperature	33.46 barg @ +170 °C	PESO A VUOTO	116 kg
MAWP(EXT)	NO	PESO IN ESERCIZIO	116 kg
MDMT @ MAWP	0 °C @ 33.46 barg	PESO PIENO D'ACQUA	214 kg
TRATTAMENTO TERMICO	NO	DATI DEL VENTO	-
P.W.H.T.	NO	Wind datas	-
IMPACT TEST	NO	DATI SISMICI	-
Exemption	NO	Seismological datas	-

Rev.	Descrizione / Description	Disegnato/Draw	Controllato/Checked	Approvato/Approved	Data/Date
05	Modified as per Client comments	CM	MV	GL	16/06/2022
04	Modified as per Client comments	CM	MV	GL	16/06/2022
03	Modified as per Customer comments	CM	MV	GL	11/05/2022
02	Aligned design pressure with datum	CM	MV	GL	15/04/2022
01	Modified strength length on cap	CM	MV	GL	30/03/2022
00	FIRST ISSUE	CM	MV	GL	16/03/2022

Oggetto/Object: N2 PULSATION DAMPER 1st STAGE DISCHARGE

Scala/Scale	1 : 5	Formato/Size	A1
Comm. N°/Job No.	C220006	Foglio/Sheet	1 - 1
Cliente/Customer	Airpack Nederland B.V.		
Ord. No.	18498-VV-0901		
Dis. N°/Dwg No.	C220006DWG004	Rev.	05

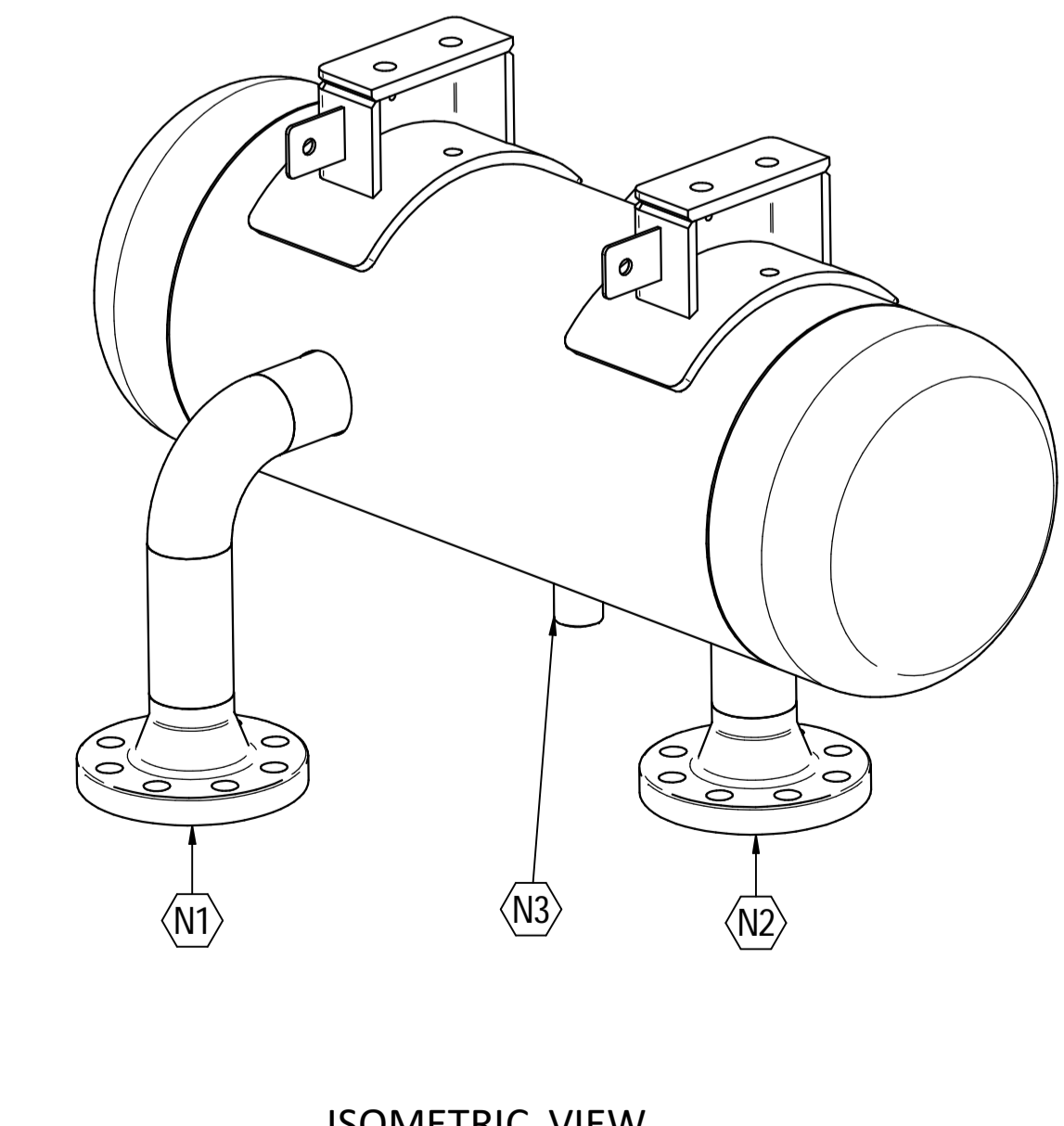
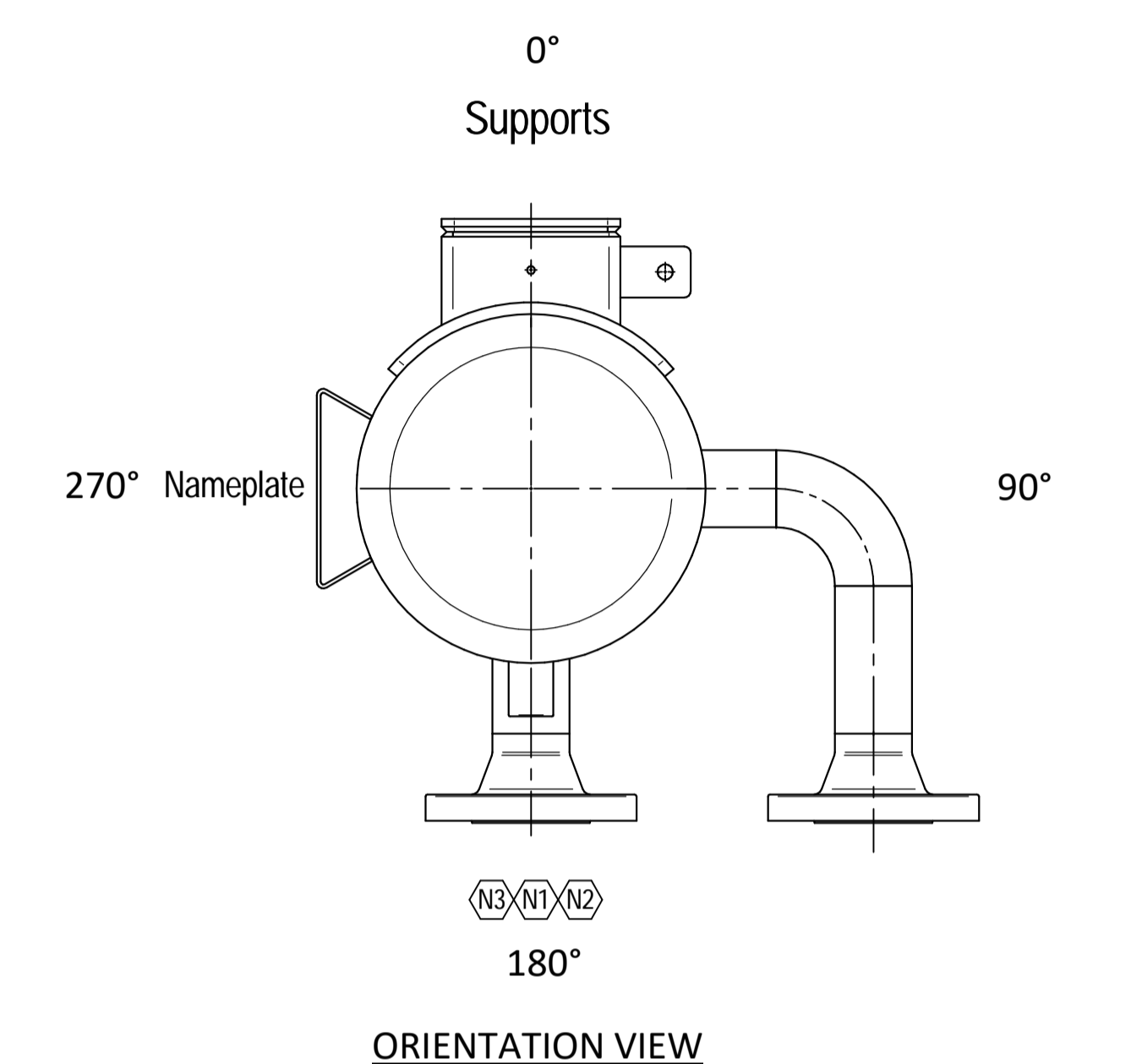
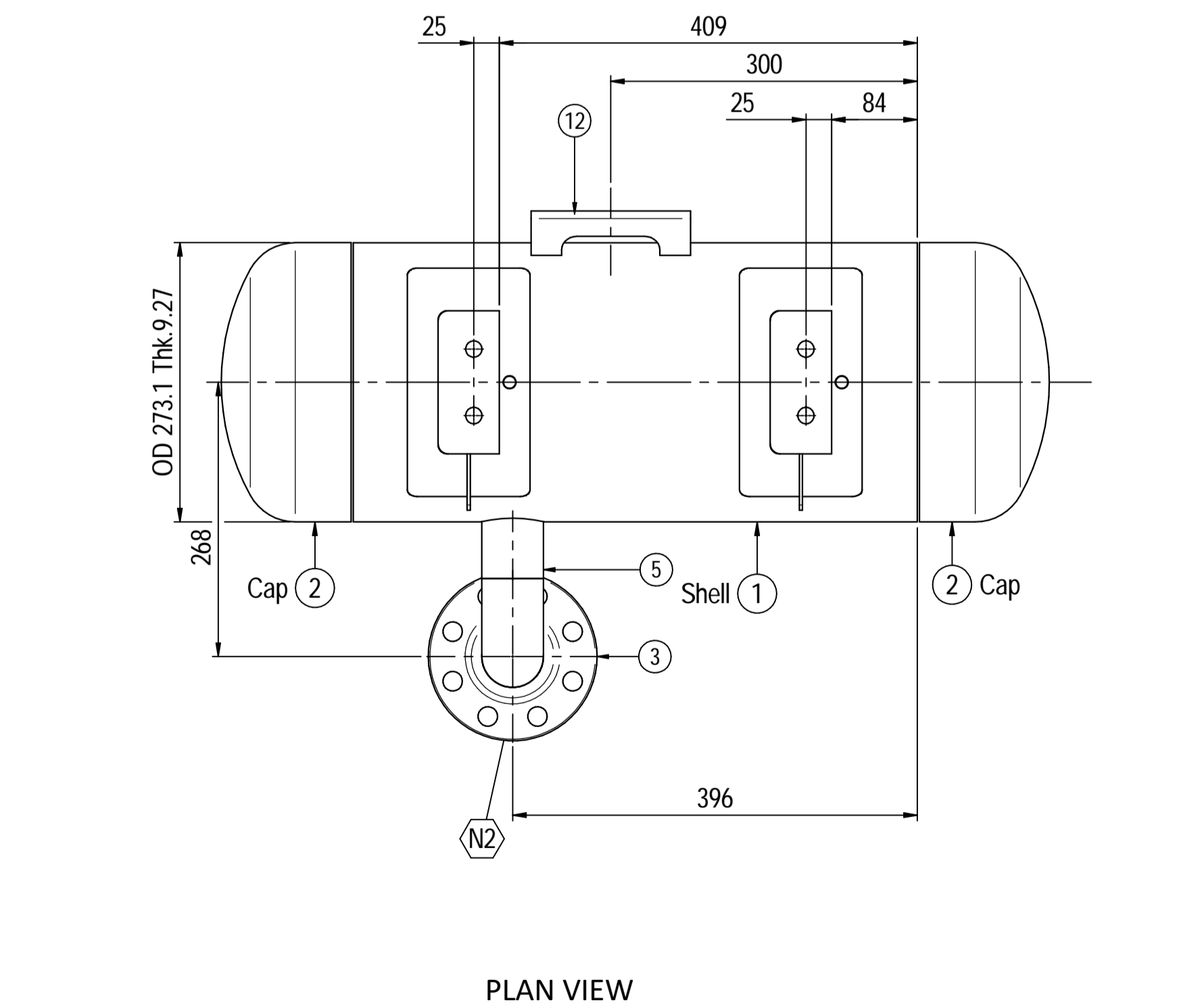
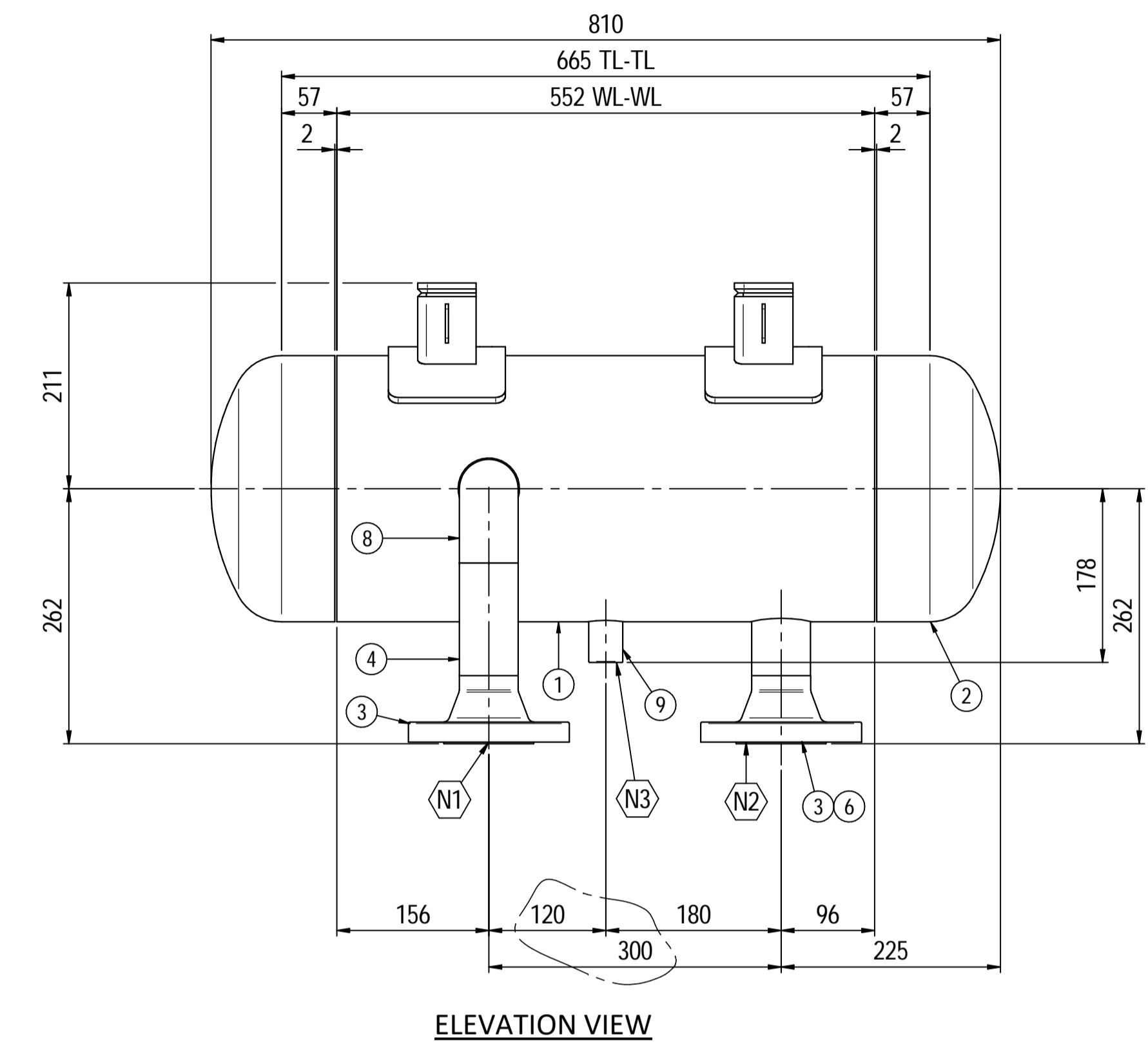
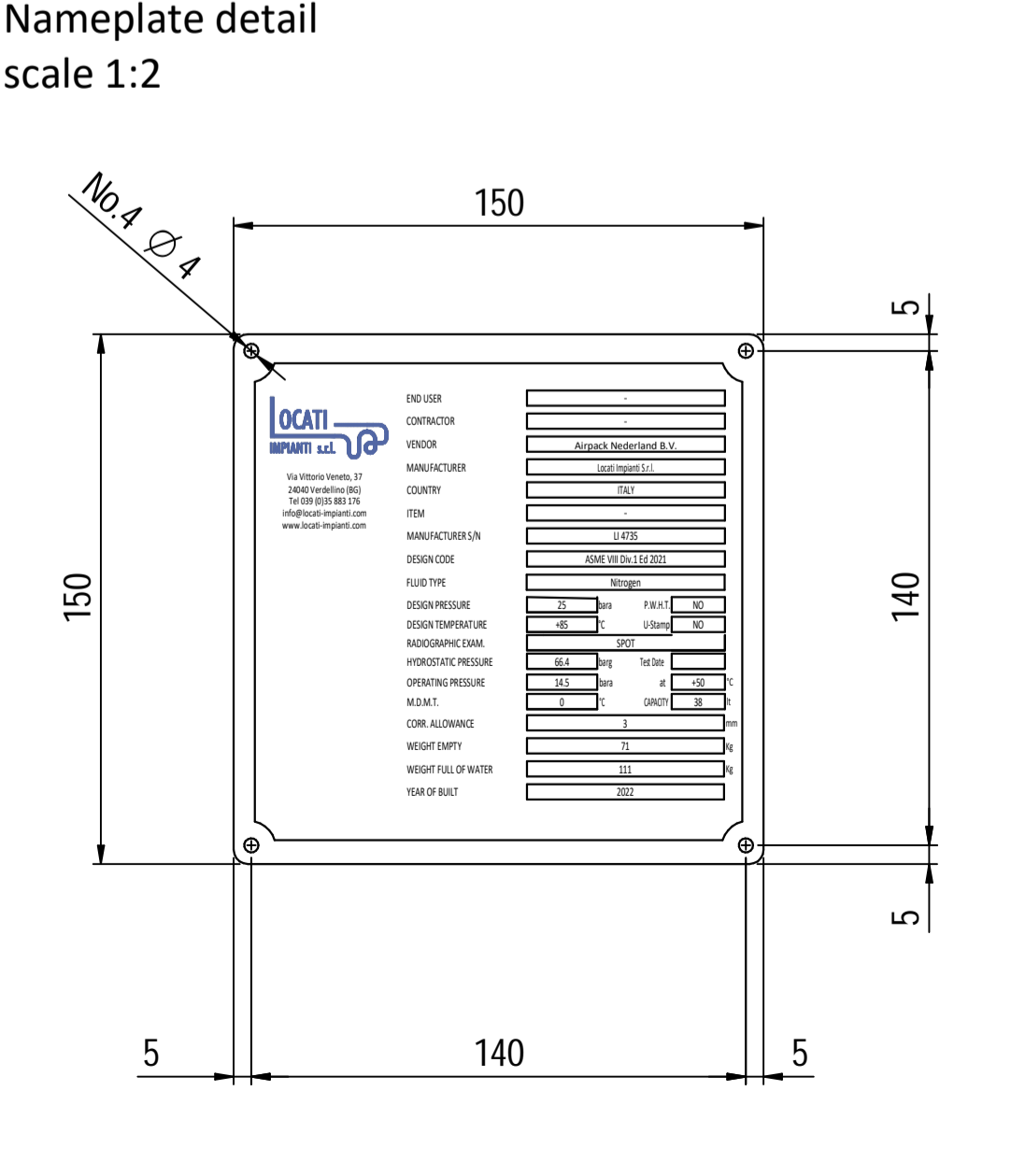
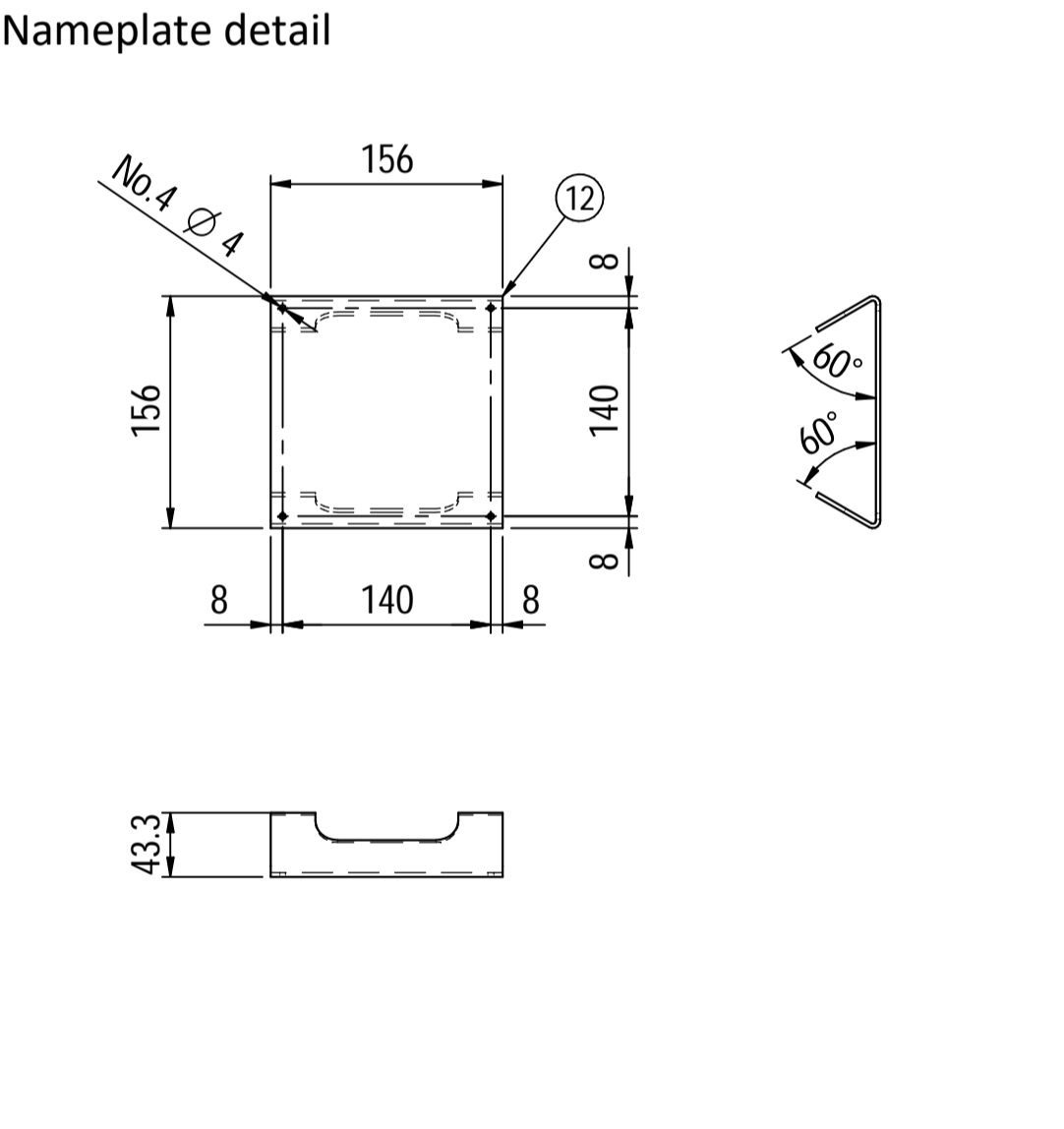
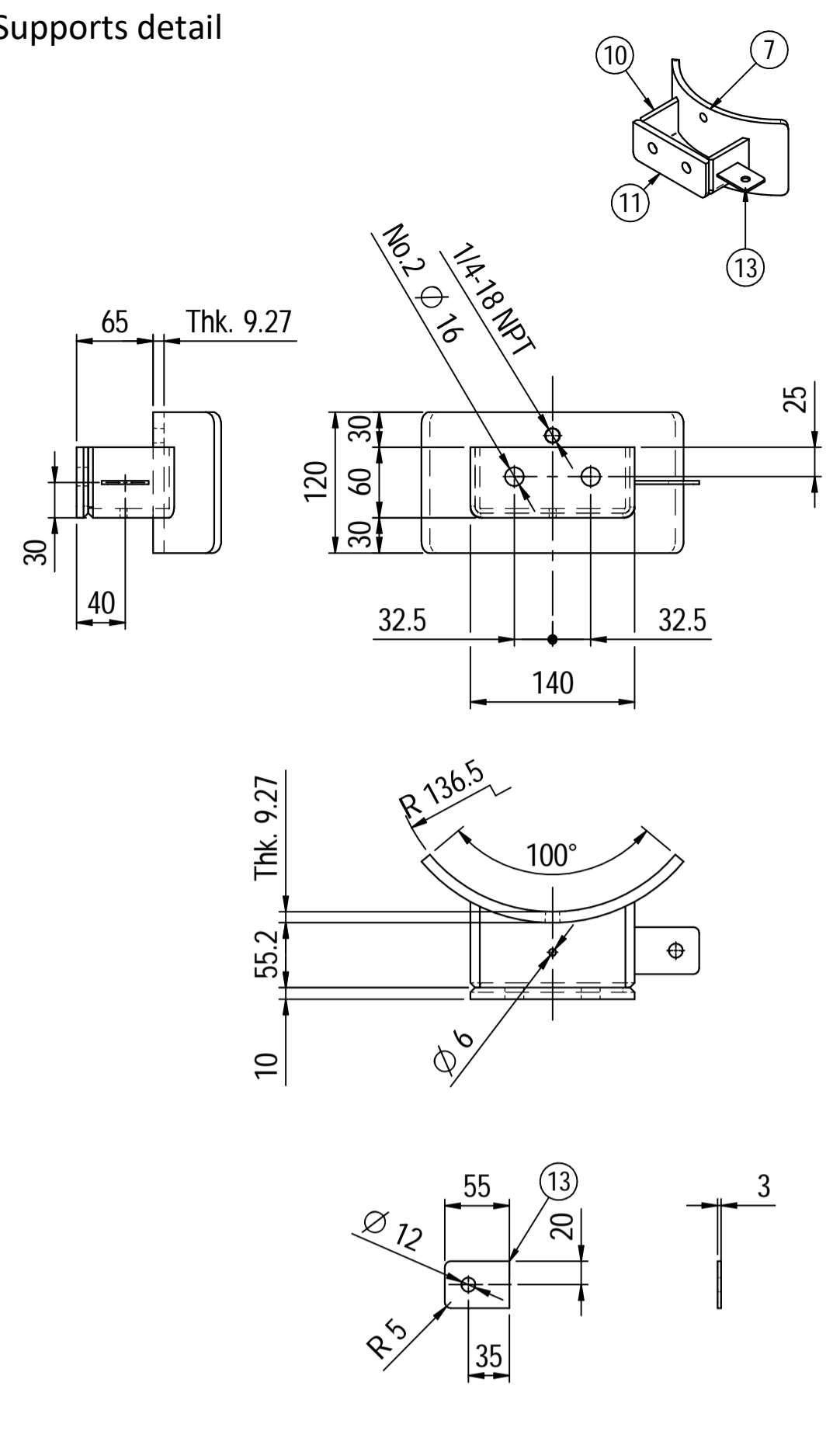

Material List					
Pos.	Q.ty	Description	Mat.	Cert.	
1	1	Shell by seamless pipe 10" Sch.STD L=552	SA106 Gr.B	3.1	
2	2	Cap 10" Sch40	A234 WPB	3.1	
3	2	Flange 2" WN #300 RF Sch.160	A105	3.1	
4	1	Seamless pipe 2" Sch160 L=115.5	A106 GrB	3.1	
5	1	Seamless pipe 2" Sch160 L=69	A106 GrB	3.1	
6	1	Seamless pipe 2" Sch160 L=68	A106 GrB	3.1	
7	2	Pad by pipe 10" Sch.STD	A106 Gr.B	3.1	
8	1	Seamless elbow 2" 90° LR Sch160	A234 WPB	3.1	
9	1	Coupling 1/2" NPT #6000	A105	3.1	
10	2	Plate 74.5x231 Thk.8	A516 70	3.1	
11	2	Plate 16x65 Thk.10	A516 70	3.1	
12	1	Nameplate support 156x241 Thk.3mm	A516 70	3.1	
13	2	Earthing Plate 55 x 40 Thk.3	A240 TP316L	3.1	

Note:
 1) Governing measurement S.I. unless otherwise specified;
 2) Flange bolt holes have to be straddled from main vessel center line in plan & vertical & horizontal centreline in elevation;
 3) Material: certification 3.1 EN 10204;
 4) All internal edge shall be rounded off;
 5) Nozzle flanges in accordance with ASME B16.5: 2013;
 6) Flange fittings in accordance with ASME B16.9: 2012;
 7) The flange dimensions are in accordance to ASME B16.5: 2013;
 8) All fillet welds not detailed on "WELDING MAP" or drawing shall have the weld; throated equal to 0,7 times the minimum thickness to be welded;
 9) All welds are continuous except where indicate;
 10) See document C220006CLC011 for vessel calculation.

ITEM	QTY	SERVICE	SIZE	O.D.	THK	RATING	TYPE	FACE	O.D.	THK.	Tc
N3	1	DRAIN	1/2"	38.1	8.38	#6000	-	NPT-F	-	-	8.5 ± 10
N2	1	AIR OUTLET	2"	60.3	8.74	#300	WN	RF	-	-	8.5 ± 10
N1	1	AIR INLET	2"	60.3	8.74	#300	WN	RF	-	-	8.5 ± 10

DATI DI PROGETTO / Design data			
FLUIDO	Nitrogen	COLLAUDO	Test
STATO FISICO DEL FLUIDO	Gas	NATIONAL BOARD REGISTRATION	NO
CODICE DI CALCOLO	ASME VIII Div. 1 Ed.2021	CANADIAN REGISTER NUMBER	NO
PRESSIONE DI ESERCIZIO	14.5 bara	SERVIZIO LETALE	NO
PRESSIONE DI PROGETTO	25 bara (24 barg)	X-RAY	RT examination
PRESSIONE ESTERNA	NO	LIQUIDI PENETRANTI	NO
PRESSIONE DI PROVA IDRAULICA	66.4 barg	ULTRASUONI	NO
TEMPERATURA DI ESERCIZIO	+50 °C	CONTROLLO MAGNETOSCOPICO	NO
TEMPERATURA DI PROGETTO	+85 °C	WELDING	NO
SOVRAMEATTO DI CORROSIONE	3 mm	PROCEDIMENTO DI SALDATURA	See doc: C220006WBK013
CAPACITA'	38 l	TIPO DI FONDO	CAP
EFFICIENZA GIUNTI	0.85	FORMAZIONE FONDO	HOT
MAWP @ Design Temperature	38.12 bar @ +85 °C	PESO A VUOTO	71 kg
MAWP(EXT)	NO	PESO IN ESERCIZIO	71 kg
MDMT @ MAWP	0 °C @ 38.12 bar	PESO PIENO D'ACQUA	111 kg
TRATTAMENTO TERMICO	NO	DATI DEL VENTO	-
IMPACT TEST	NO	DATI SISMICI	-

05	Modified as per Client comments	CM	MV	GL	16/06/2022
04	Modified as per Client comments	CM	MV	GL	11/05/2022
03	Modified as per Client comments	CM	MV	GL	15/04/2022
02	Modified as per Customer comments	CM	MV	GL	02/04/2022
01	Modified shell length	CM	MV	GL	30/03/2022
00	FIRST ISSUE	CM	MV	GL	16/03/2022

Rev.	Descrizione / Description	Disegnato/Draw	Controllato/Checked	Approvato/Approved	Data/Date																				
Oggetto/Object N2 PULSATION DAMPER 2nd STAGE SUCTION																									
<table border="0"> <tr> <td>Scala/Scale</td> <td>1 : 5</td> <td>Formato/Size</td> <td>A1</td> </tr> <tr> <td>Comm. N°/Job No.</td> <td>C220006</td> <td>Foglio/Sheet</td> <td>1 - 1</td> </tr> <tr> <td>Cliente/Customer</td> <td>Airpack Nederland B.V.</td> <td colspan="2"></td> </tr> <tr> <td>Ord. No.</td> <td>18498-VV-0901</td> <td colspan="2"></td> </tr> <tr> <td>Dis. N°/Dwg No.</td> <td>C220006DWG005</td> <td>Rev.</td> <td>05</td> </tr> </table>						Scala/Scale	1 : 5	Formato/Size	A1	Comm. N°/Job No.	C220006	Foglio/Sheet	1 - 1	Cliente/Customer	Airpack Nederland B.V.			Ord. No.	18498-VV-0901			Dis. N°/Dwg No.	C220006DWG005	Rev.	05
Scala/Scale	1 : 5	Formato/Size	A1																						
Comm. N°/Job No.	C220006	Foglio/Sheet	1 - 1																						
Cliente/Customer	Airpack Nederland B.V.																								
Ord. No.	18498-VV-0901																								
Dis. N°/Dwg No.	C220006DWG005	Rev.	05																						

Supports detail

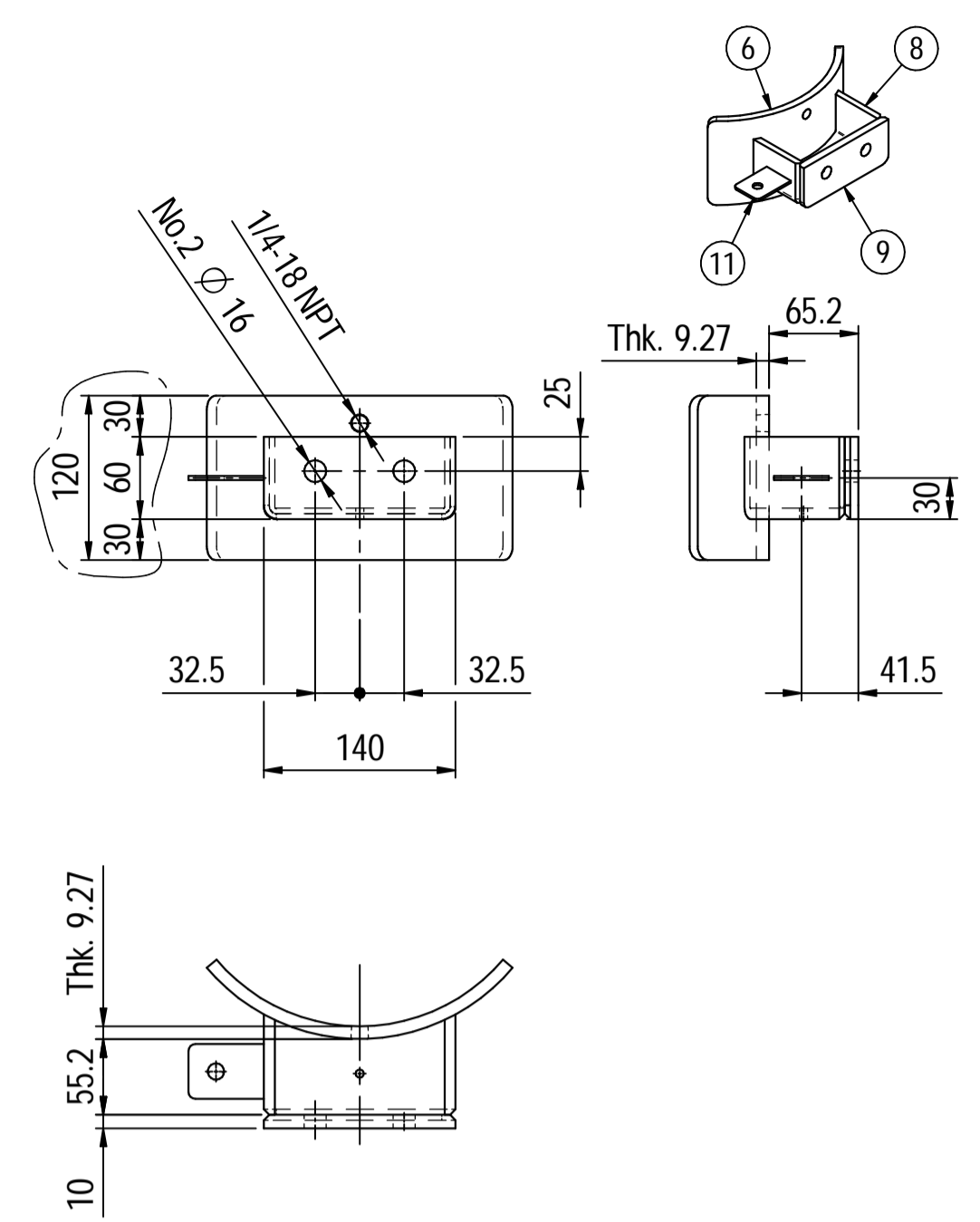

Nameplate detail

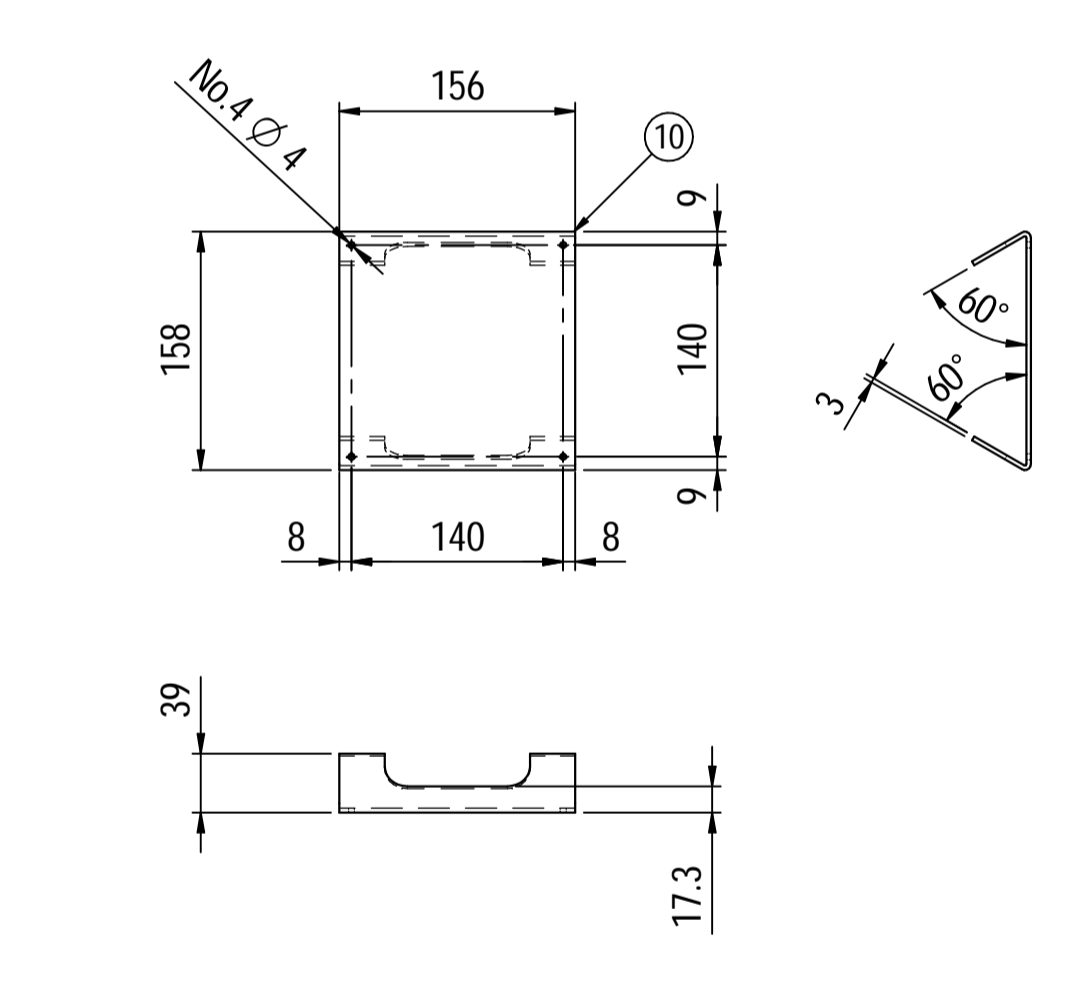

Nameplate detail scale 1:2

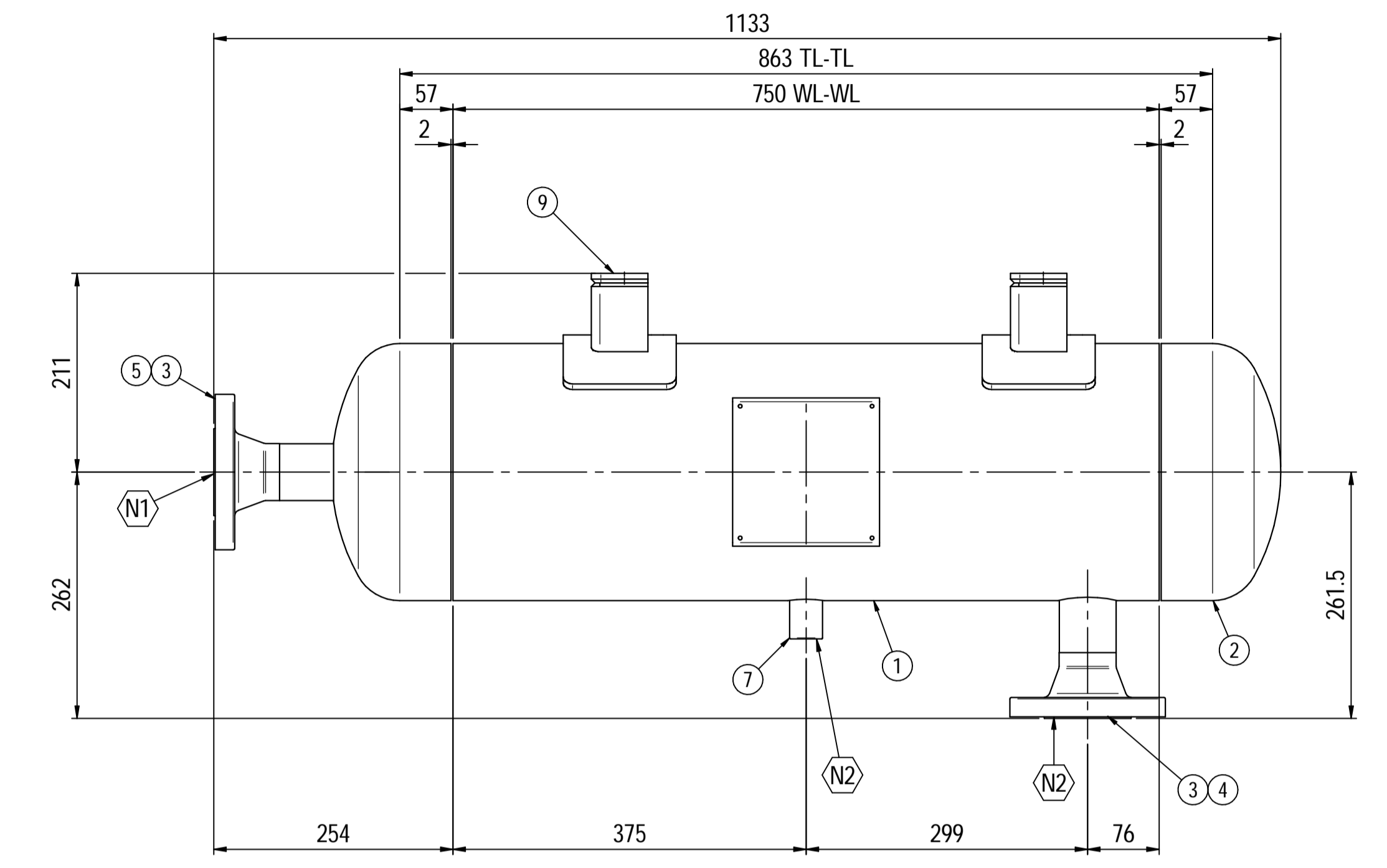
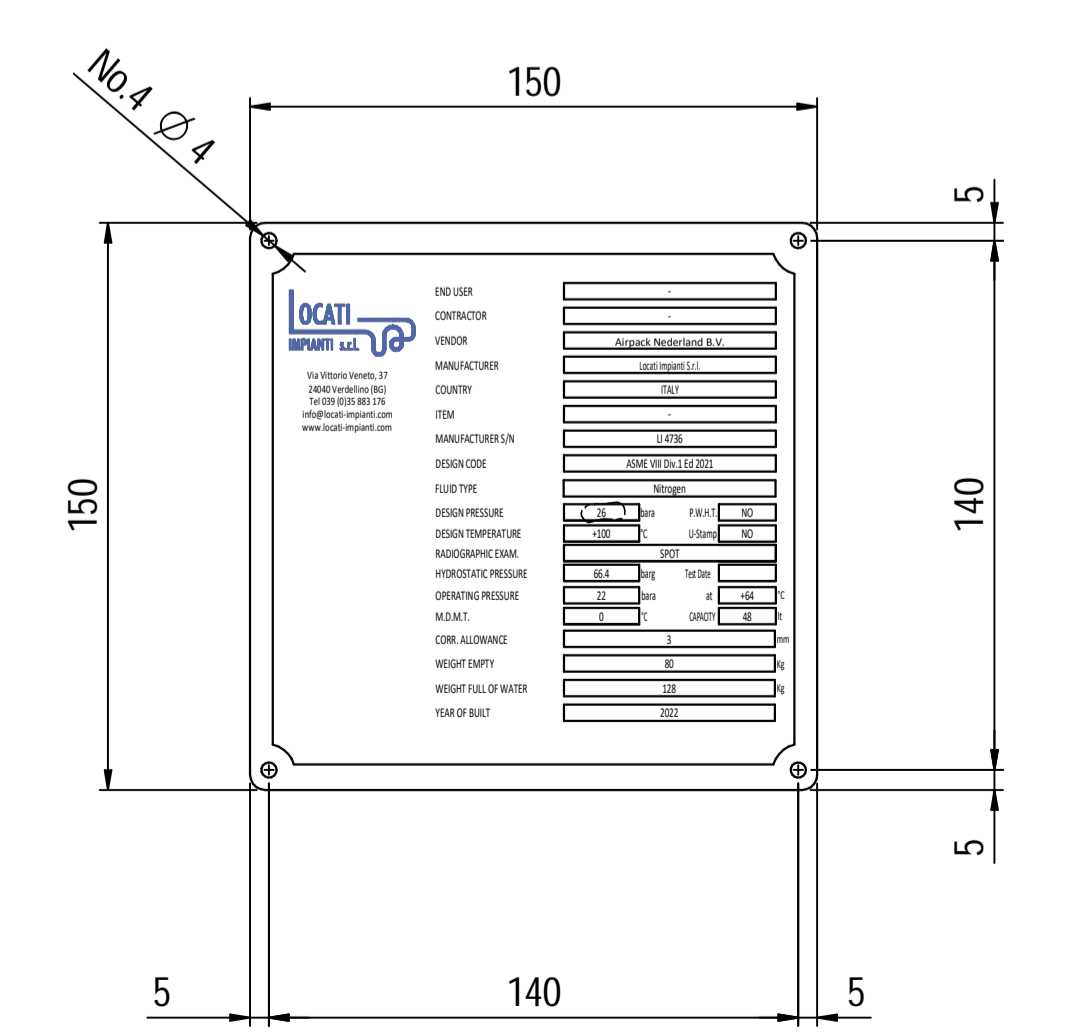

ELEVATION VIEW

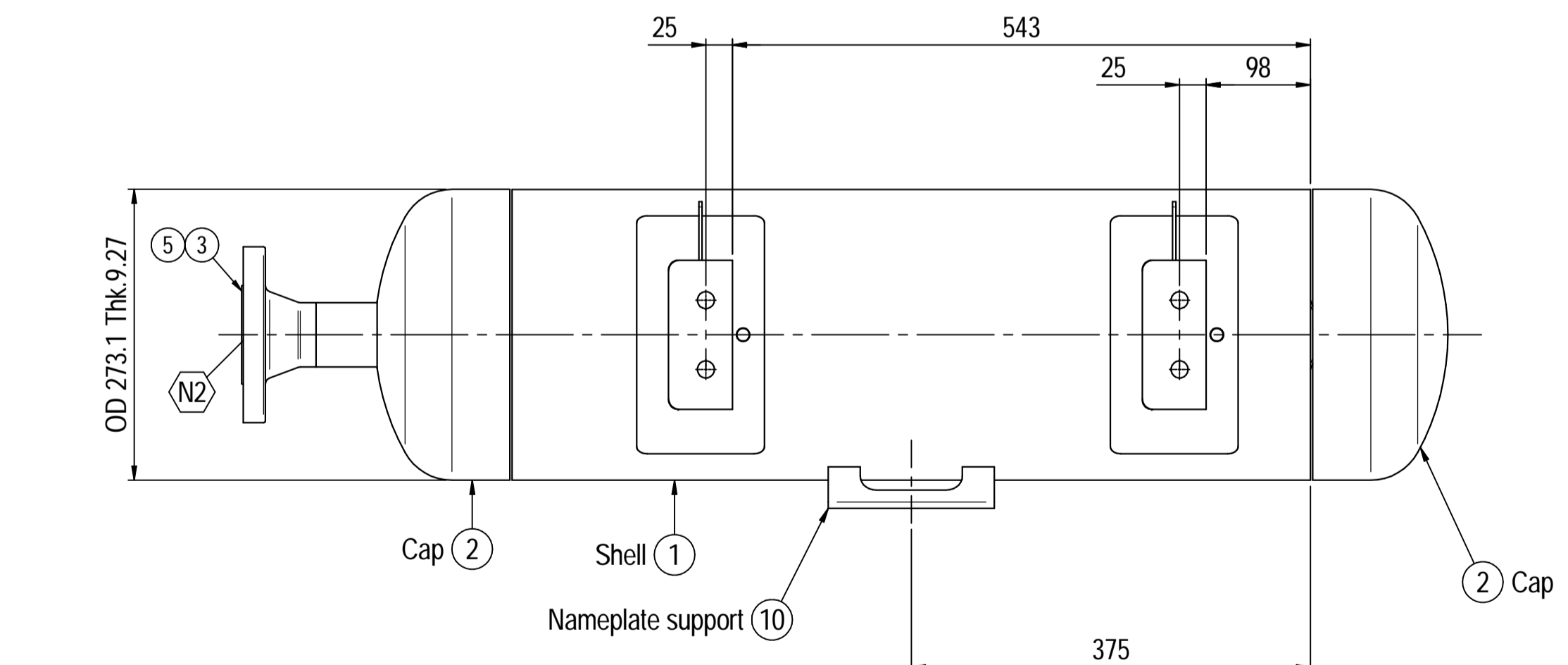

PLAN VIEW

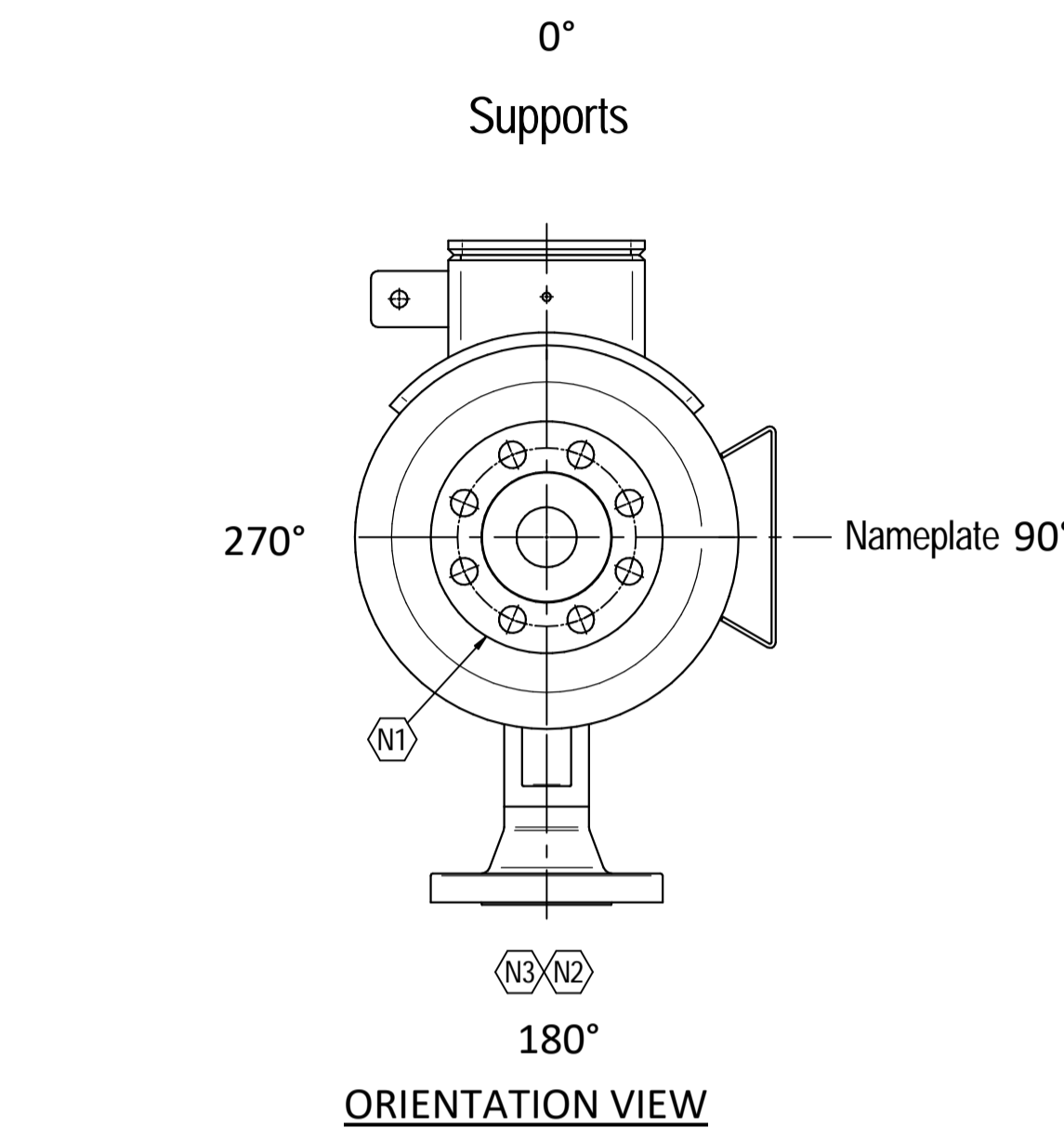

ISOMETRIC VIEW scale 1:8

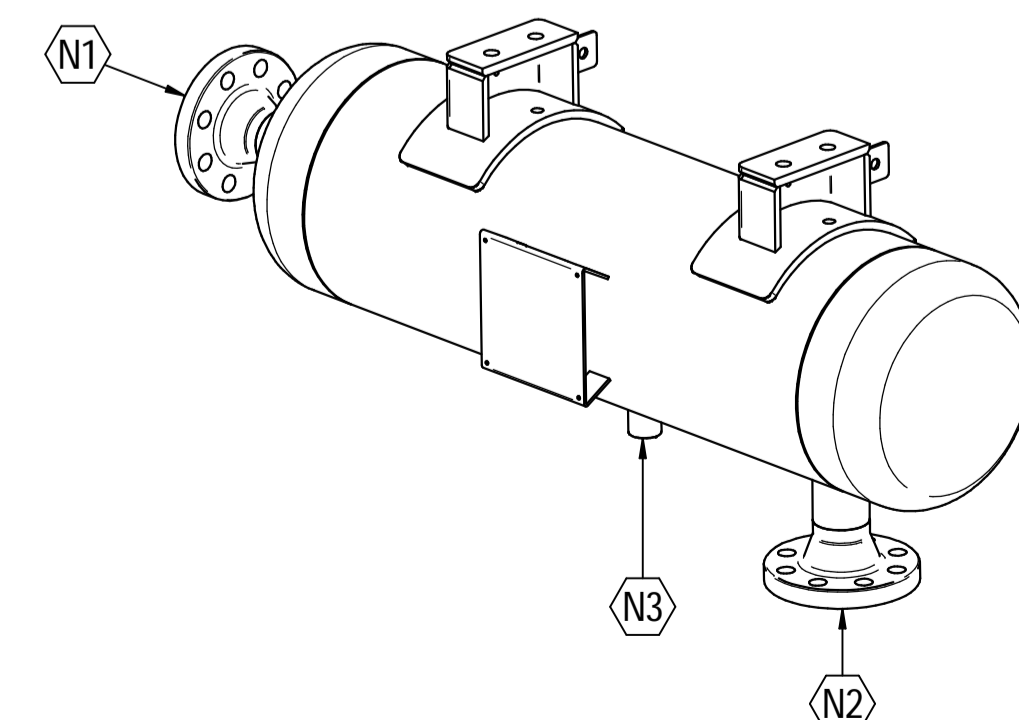

Material List				
Pos.	Q.ty	Description	Mat.	Cert.
1	1	Shell by seamless pipe 10" Sch.STD L=750	SA106 Gr.B	3.1
2	2	Cap 10" Sch40	A234 WPB	3.1
3	2	Flange 2" WN #300 RF Sch.160	A105	3.1
4	1	Seamless pipe 2" Sch160 L=68	A106 GrB	3.1
5	1	Seamless pipe 2" Sch160 L=65	A106 GrB	3.1
6	2	Pad by pipe 10" Sch.STD	A106 Gr.B	3.1
7	1	Coupling 1/2" NPT #6000	A105	3.1
8	2	Plate 74.5x231 Thk.8	A516 70	3.1
9	2	Plate 16x65 Thk.10	A516 70	3.1
10	1	Nameplate support 234 x 156 thk3mm	S275 JR	3.1
11	2	Earthing Plate 55 x 40 Thk.3	A240 TP316L	

Note:
 1) Governing measurement S.I. unless otherwise specified;
 2) Flange bolt holes have to be straddled from main vessel center line in plan & vertical & horizontal centreline in elevation;
 3) Material: certification 3.1 EN 10204;
 4) All internal edge shall be rounded off;
 5) Nozzle flanges in accordance with ASME B16.5: 2013;
 6) Flange fittings in accordance with ASME B16.5: 2012;
 7) The flange dimensions are in accordance to ASME B16.5: 2013;
 8) All fillet welds not detailed on "WELDING MAP" or drawing shall have the weld; throated equal to 0,7 times the minimum thickness to be welded;
 9) All welds are continuous except where indicate;
 10) See document C220006CLC012 for vessel calculation.

ITEM	QTY	SERVICE	SIZE	O.D.	THK	RATING	TYPE	FACE	O.D.	THK.	Tc
N3	1	DRAIN	1/2"	38.1	8.38	#6000	-	NPT-F	-	-	8.5 + 10
N2	1	AIR OUTLET	2"	60.3	8.74	#300	WN	RF	-	-	8.5 + 10
N1	1	AIR INLET	2"	60.3	8.74	#300	WN	RF	-	-	8.5 + 10

DATI DI PROGETTO / Design data			
FLUIDO	Nitrogen	COLLAUDO	Test
STATO FISICO DEL FLUIDO	Gas	NATIONAL BOARD REGISTRATION	NO
CODICE DI CALCOLO	ASME VIII Div. 1 Ed.2021	CANADIAN REGISTER NUMBER	NO
PRESSIONE DI ESERCIZIO	23 bara	SERVIZIO LETALE	NO
PRESSIONE DI PROGETTO	(26bara (25 barg))	X-RAY	RT examination
PRESSIONE ESTERNA	NO	LICUIDI PENETRANTI	NO
PRESSIONE DI PROVA IDRAULICA	66.4 barg	Dye penetrant extension	NO
TEMPERATURA DI ESERCIZIO	+83 °C	ULTRASUONI	NO
TEMPERATURA DI PROGETTO	+100 °C	ULTRASONIC extension	NO
SOVRAMEZZA	3 mm	CONTROLLO MAGNETOSCOPICO	NO
CAPACITA'	48 l	Magnetic particle examination	NO
EFFICIENZA GIUNTI	0.85	TALONE DI SALDATURA	NO
WAWP @ Design Temperature	38.12 barg @ +100 °C	PROCEDIMENTO DI SALDATURA	See doc.C220006WBK013
WAWP(EXT)	NO	Weld tests coupon	NO
MDMT @ WAWP	0 °C @ 38.12 barg	SOVRAMEZZA DI CORROSIONE	NO
TRATTAMENTO TERMICO	NO	Corrosion allowance	3 mm
IMPACT TEST	NO	Welding procedure	See doc.C220006WBK013
IMPACT TEST	NO	TIPO DI FONDO	CAP
IMPACT TEST	NO	FORMAZIONE FONDO	HOT
IMPACT TEST	NO	Head form	NO
IMPACT TEST	NO	PESO A VUOTO	80 kg
IMPACT TEST	NO	PESO IN ESERCIZIO	80 kg
IMPACT TEST	NO	PESO PIENO D'ACQUA	128 kg
IMPACT TEST	NO	Peso pieno d'acqua	128 kg
IMPACT TEST	NO	Wind data	-
IMPACT TEST	NO	Seismological data	-

Rev.	Descrizione / Description	Disegnato/Draw	Controllato/Checked	Approvato/Approved	Data/Date
05	Modified as per Client comments	CM	MV	GL	16/06/2022
04	Modified design pressure	CM	MV	GL	03/06/2022
03	Modified as per Client comments	CM	MV	GL	11/05/2022
02	Modified as per Client comments	CM	MV	GL	15/04/2022
01	Modified shell length	CM	MV	GL	30/03/2022
00	FIRST ISSUE	CM	MV	GL	16/03/2022

Oggetto/Object			
N2 PULSATION DAMPER 2nd STAGE DISCHARGE			
Scala/Scale	1 : 5	Formato/Size	A1
Comm. N°/Job No.	C220006	Foglio/Sheet	1 - 1
Cliente/Customer	Airpack Nederland B.V.		
Ord. No.	18498-VV-0901		
Dis. N°/Dwg No.	C220006DWG006	Rev.	05