





OWNER:  شرکت سست و سویی توهمه ایران (سهامی خاص)	<b>BUSHEHR PETROCHEMICAL COMPANY MEG PLANT</b>						EPC CONTRACTOR:  Chagalesh-Enerchimi-Steam Joint Venture BUPC-MEG PLANT PROJECT		
	<b>PULSATION DAMPER DETAIL DRAWING FOR EMERGENCY INSTRUMENT AIR COMPRESSOR</b>						 Netherlands		
MC :  شرکت سست و سویی توهمه ایران (سهامی خاص)	Project	Area	Phase	Unit	Dis.	Doc.	Seq.	Contract No : 52-98/445	
Owner Document Number: 17811-23D	BU	20	VD	303	ME	DWG	0080	Rev.:	Page
								05	1 of 4

## PULSATION DAMPER DETAIL DRAWING FOR EMERGENCY INSTRUMENT AIR COMPRESSOR

05	16/06/2022	Approved for Construction	KP	CL	JR	
04	03/06/2022	Approved for Construction	KP	CL	JR	
03	13/05/2022	Approved for Construction	KP	CL	JR	
02	06/05/2022	Approved for Construction	KP	CL	JR	
01	26/04/2022	For approval	KP	CL	JR	
00	06/04/2022	For approval	KP	CL	JR	
<b>Rev.</b>	<b>Date</b>	<b>Purpose of Issue</b>	<b>Prepared</b>	<b>Checked</b>	<b>Approved</b>	<b>AC Code</b>
					<b>Class: 1</b>	<b>Phase: P</b>



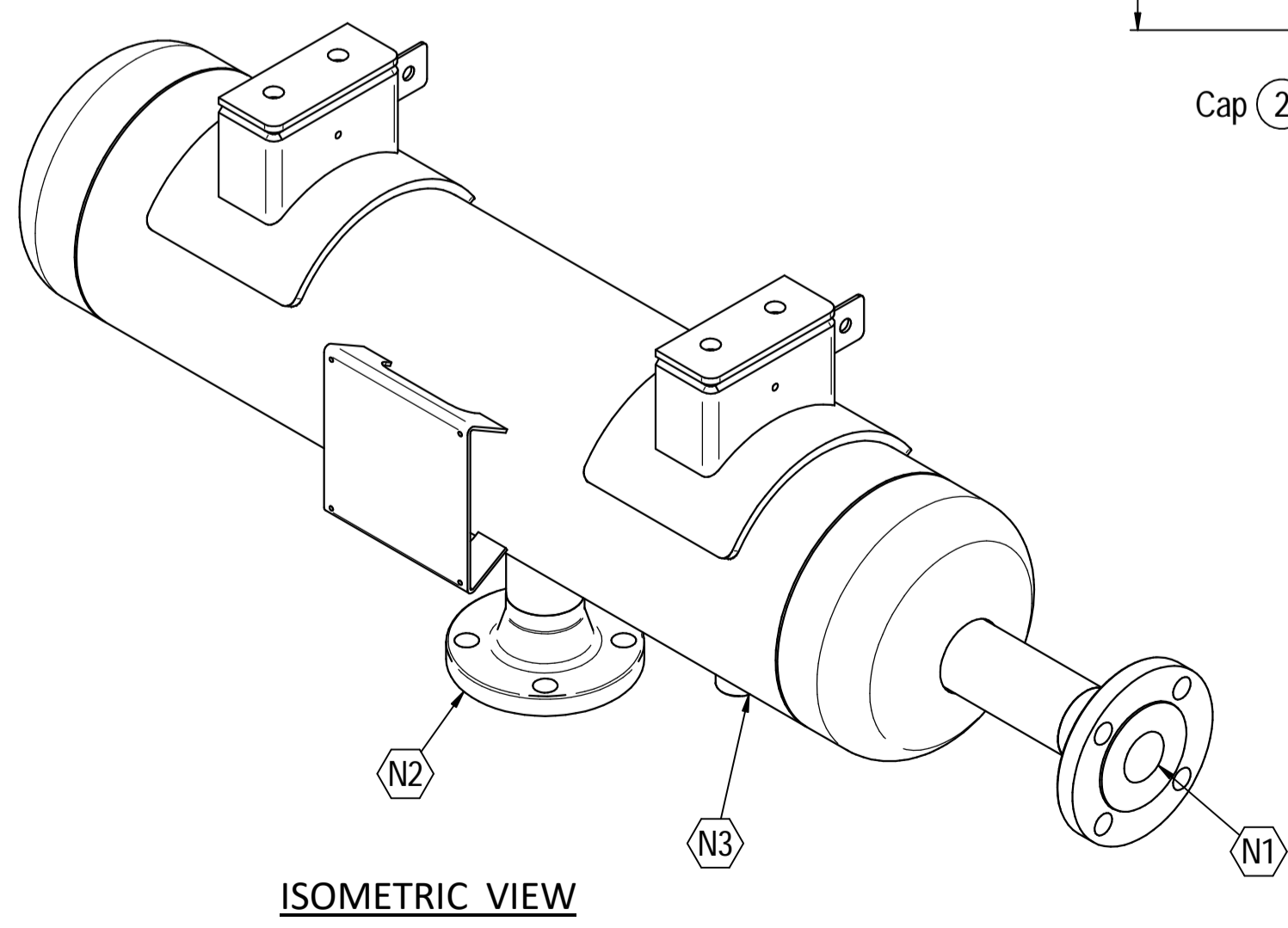
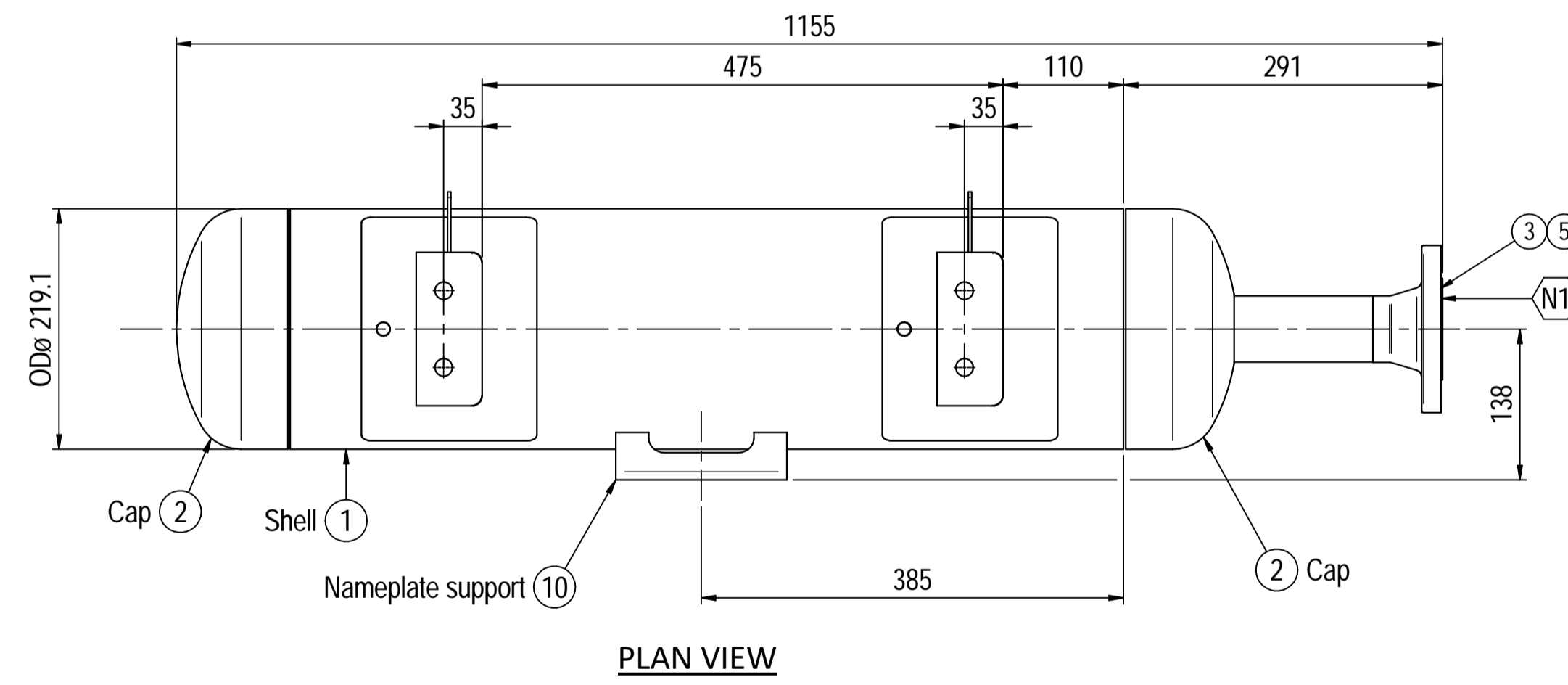
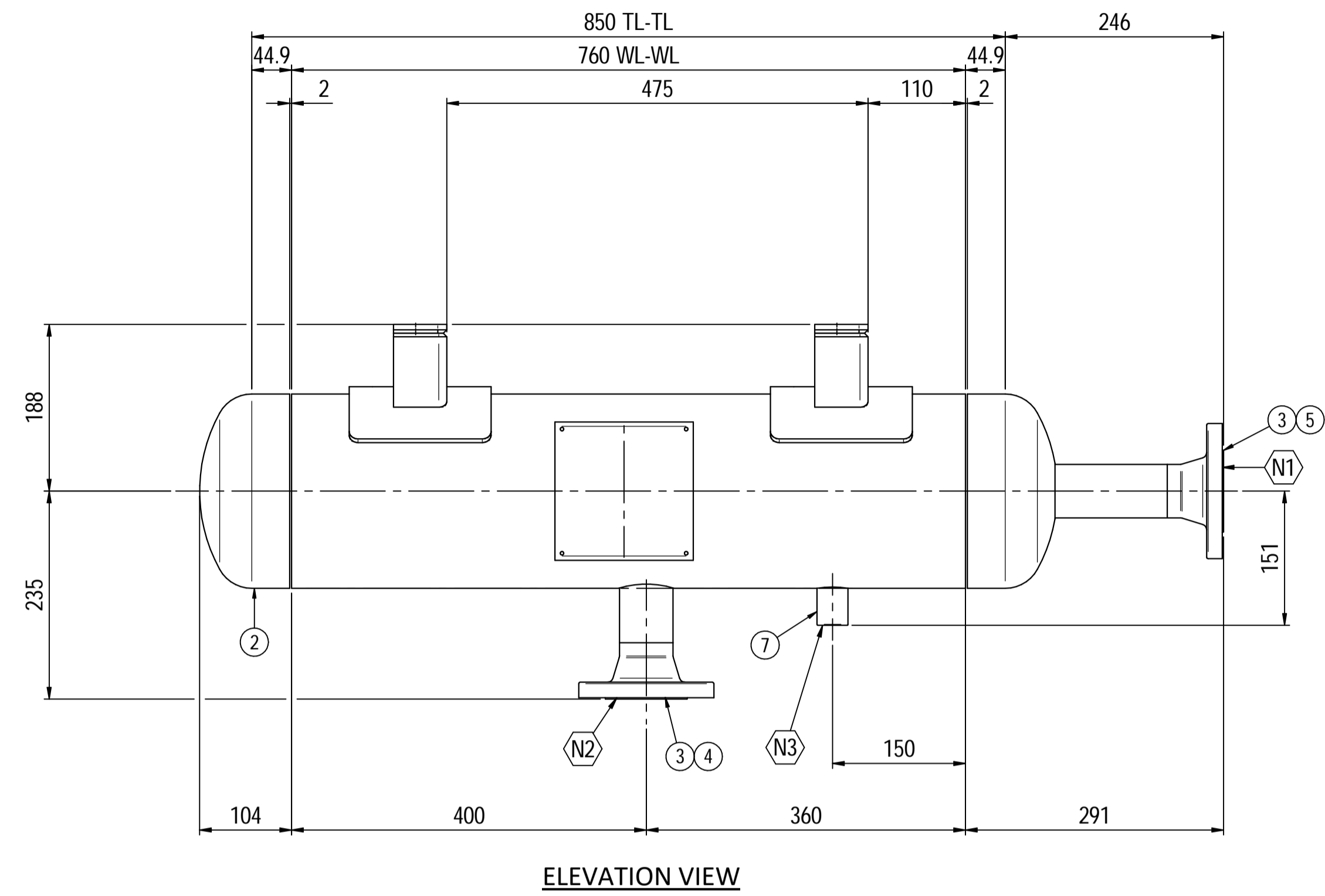
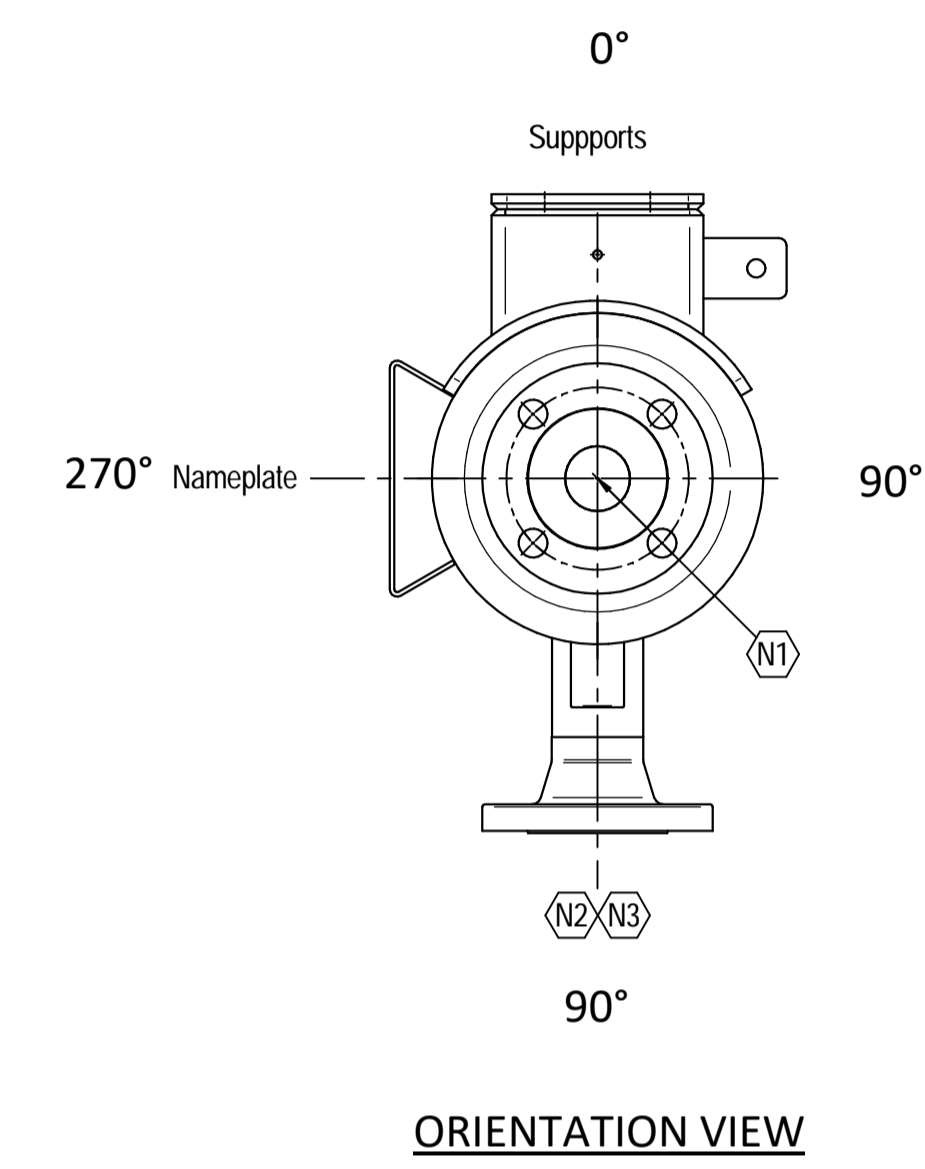
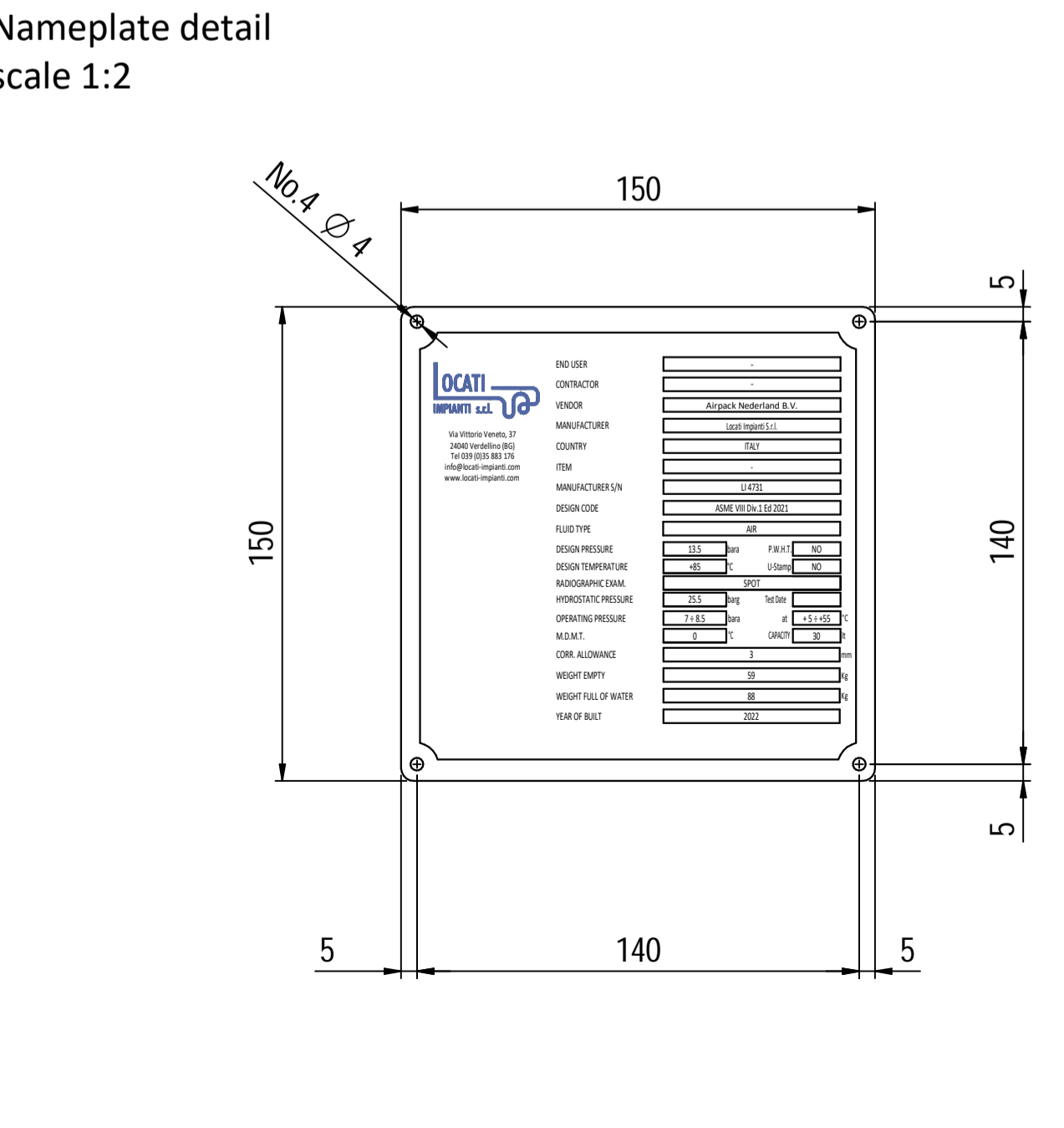
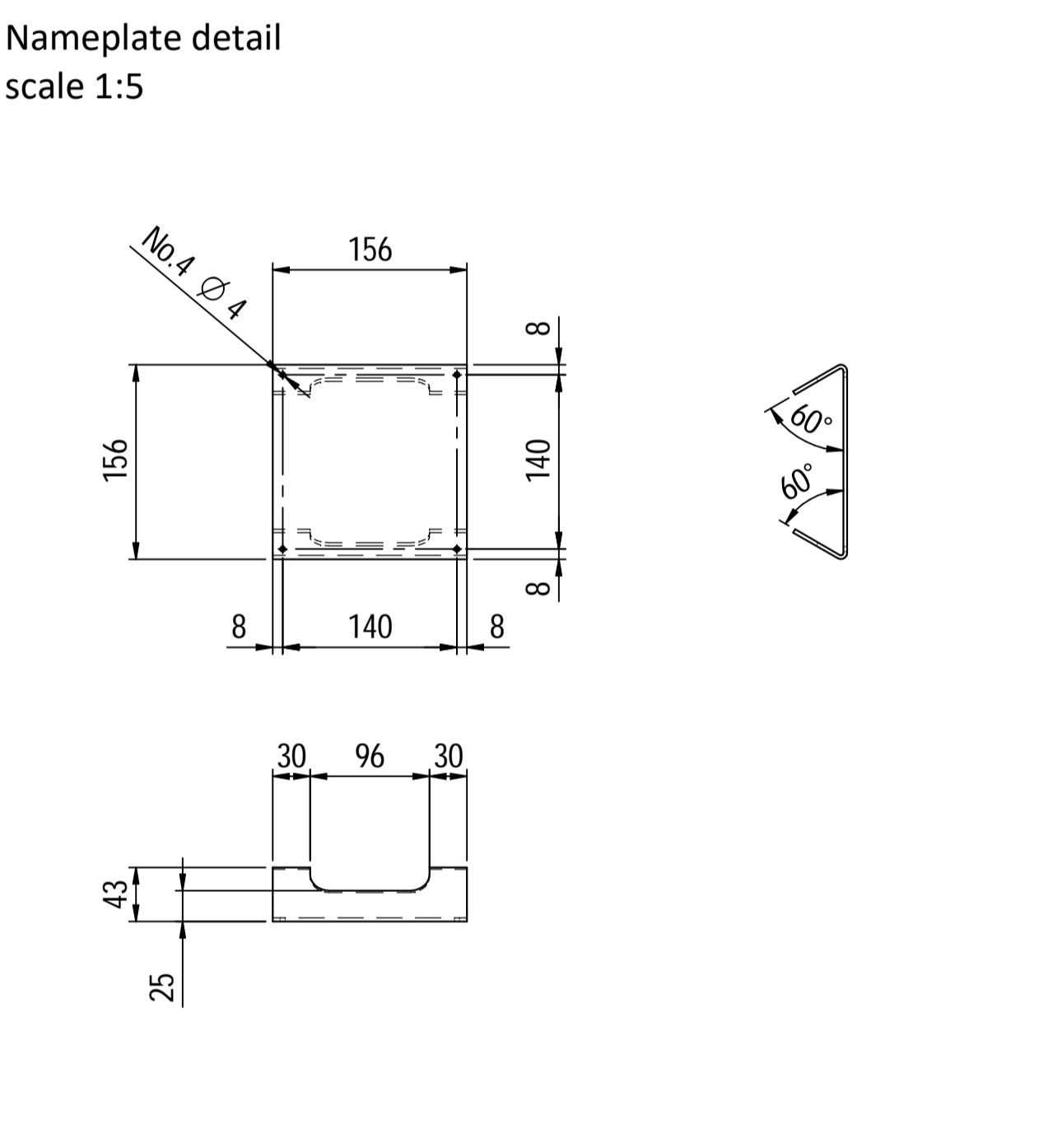
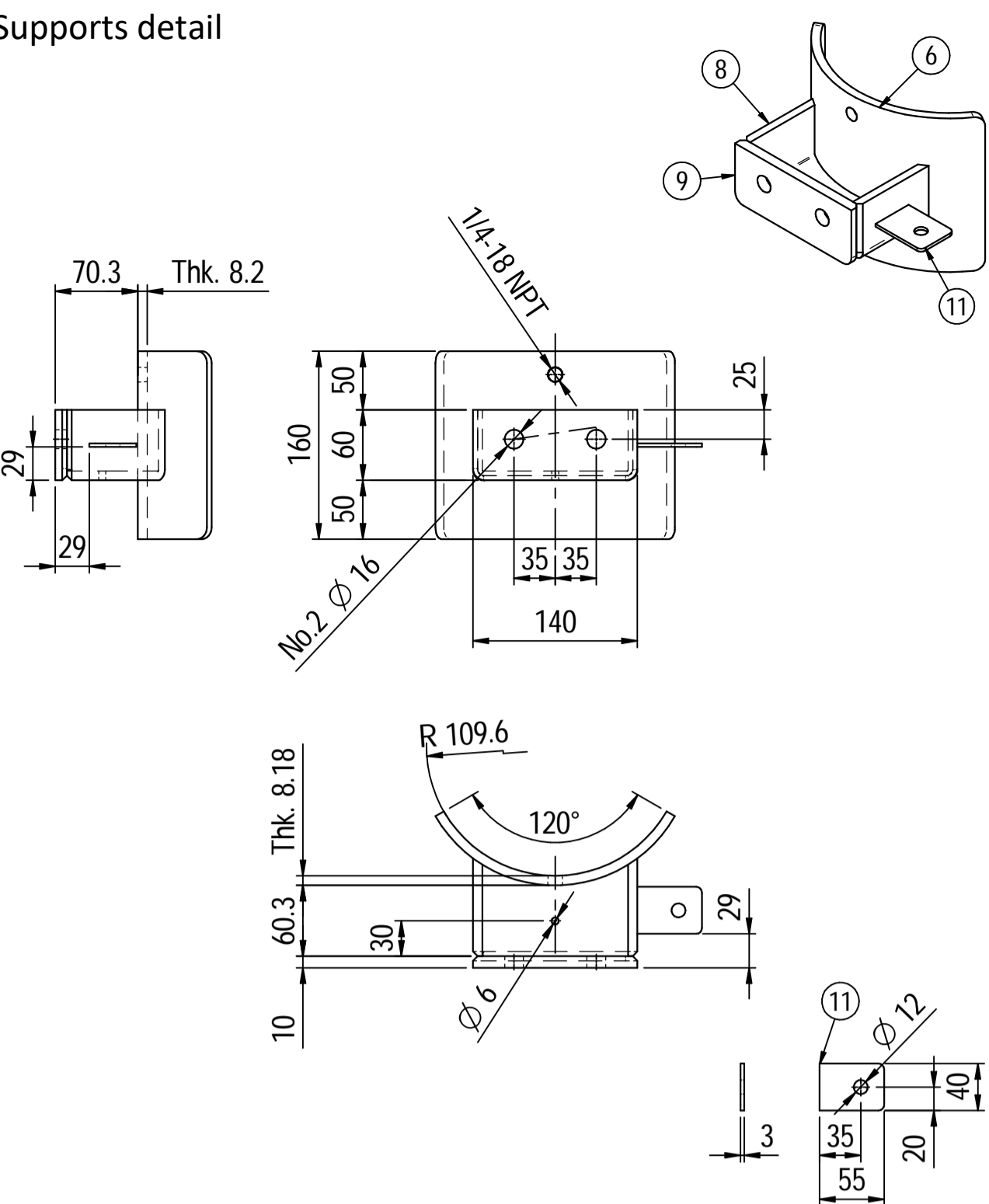

Material List					
Pos.	Q.ty	Description	Mat.	Cert.	
1	1	Shell by seamless pipe 8" Sch.40 L=760	A106 Gr.B	3.1	
2	2	Cap 8" Sch40	A234 WPB	3.1	
3	2	Flange 2" WN 150# Sch160	SA105	3.1	
4	1	Seamless pipe 2" Sch160 L=74	A106 Gr.B	3.1	
5	1	Seamless pipe 2" Sch160 L=72	A106 Gr.B	3.1	
6	2	Pad by pipe 8" Sch.40	A106 Gr.B	3.1	
7	1	Coupling 1/2" NPT #6000	A105	3.1	
8	2	Plate 83x231 Thk.8	A516 70	3.1	
9	2	Plate 60x140 Thk.10	A516 70	3.1	
10	1	Nameplate support 156x241 Thk.3mm	A516 70	3.1	
11	2	Earthing Plate 55 x 40 Thk.3	A240 TP316L	3.1	

Note:  
 1) Governing measurement S.I. unless otherwise specified;  
 2) Flange bolt holes have to be straddled from main vessel center line in plan & vertical & horizontal centreline in elevation;  
 3) Material: certification 3.1 EN 10204;  
 4) All internal edge shall be rounded off;  
 5) Nozzle fittings in accordance with ASME B16.5: 2013;  
 6) Flange fittings in accordance with ASME B16.9: 2012;  
 7) The flange dimensions are in accordance to ASME B16.5: 2013;  
 8) All fillet welds not detailed on "WELDING MAP" or drawing shall have the weld; throated equal to 0,7 times the minimum thickness to be welded;  
 9) All welds are continuous except where indicate;  
 10) See document C220006CLC007 for vessel calculation.

ITEM	QTY	SERVICE	SIZE	O.D.	THK	RATING	TYPE	FACE	O.D.	THK.	Tc
N3	1	DRAIN	1/2"	38.1	8.38	#6000	-	NPT-F	-	-	8.5 + 10
N2	1	AIR OUTLET	2"	60.3	8.74	#150	WN	RF	-	-	8.5 + 10
N1	1	AIR INLET	2"	60.3	8.74	#150	WN	RF	-	-	8.5 + 10

DATI DI PROGETTO / Design data			
FLUIDO	Air	COLLAUDO	Test
STATO FISICO DEL FLUIDO	Gas	NATIONAL BOARD REGISTRATION	NO
CODICE DI CALCOLO	ASME VIII Div. 1 Ed.2021	CANADIAN REGISTER NUMBER	NO
PRESSIONE DI ESERCIZIO	7 - 8.5 bara	SERVIZIO LETALE	NO
PRESSIONE DI PROGETTO	13.5 bara (12.5 barg)	X-RAY	RT examination
PRESSIONE ESTERNA	NO	LICUIDI PENETRANTI	NO
PRESSIONE DI PROVA IDRAULICA	25.5 barg	DYE PENETRANT EXTENSION	NO
TEMPERATURA DI ESERCIZIO	5 + 55°C	ULTRASUONI	NO
TEMPERATURA DI PROGETTO	85 °C	ULTRASONIC EXTENSION	NO
SOVRAME TALLO DI CORROSIONE	3 mm	CONTROLLO MAGNETOSCOPICO	NO
CAPACITA'	30 l	MAGNETIC PARTICLE EXAMINATION	NO
EFFICIENZA GIUNTI	0.85	WELD TEST COUPON	NO
MAWP @ Design Temperature	18.15 barg @ +85°C	PROCEDIMENTO DI SALDATURA	See doc C220006WBK013
MAWP(EXT)	NO	TIPO DI FONDO	CAP
MDMT @ MAWP	0 °C @ 18.15 barg	FORMAZIONE FONDO	HOT
TRATTAMENTO TERMICO	NO	PESO A VUOTO	59 kg
P.W.H.T.	NO	PESO IN ESERCIZIO	59 kg
IMPACT TEST	NO	PESO PIENO D'ACQUA	88 kg
		DATI DEL VENTO	-
		Wind data	-
		DATI SISMICI	-
		Seismological data	-

Rev.	Descrizione / Description	Disegnato/Draw	Controllato/Checked	Approvato/Approved	Data/Date
05	Modified as per Client comments	CM	MV	GL	16/06/2022
04	Modified as per Client comments	CM	MV	GL	11/05/2022
03	Modified as per Client comments	CM	MV	GL	15/04/2022
02	Modified as per Customer comments	CM	MV	GL	02/04/2022
01	Modified earthing lug	CM	MV	GL	25/03/2022
00	FIRST ISSUE	CM	MV	GL	16/03/2022

Objetto/Object: PULSATION DAMPER INLET

Scale/Scale: 1 : 5  
 Comm. N°/Job No.: C220006  
 Cliente/Customer: Airpack Nederland B.V.  
 Ord. No.: 18498-VV-0901  
 Dis. N°/Dwg No.: C220006DWG001  
 Rev.: 05

LOCATI IMPIANTI s.r.l.

**Supports detail**

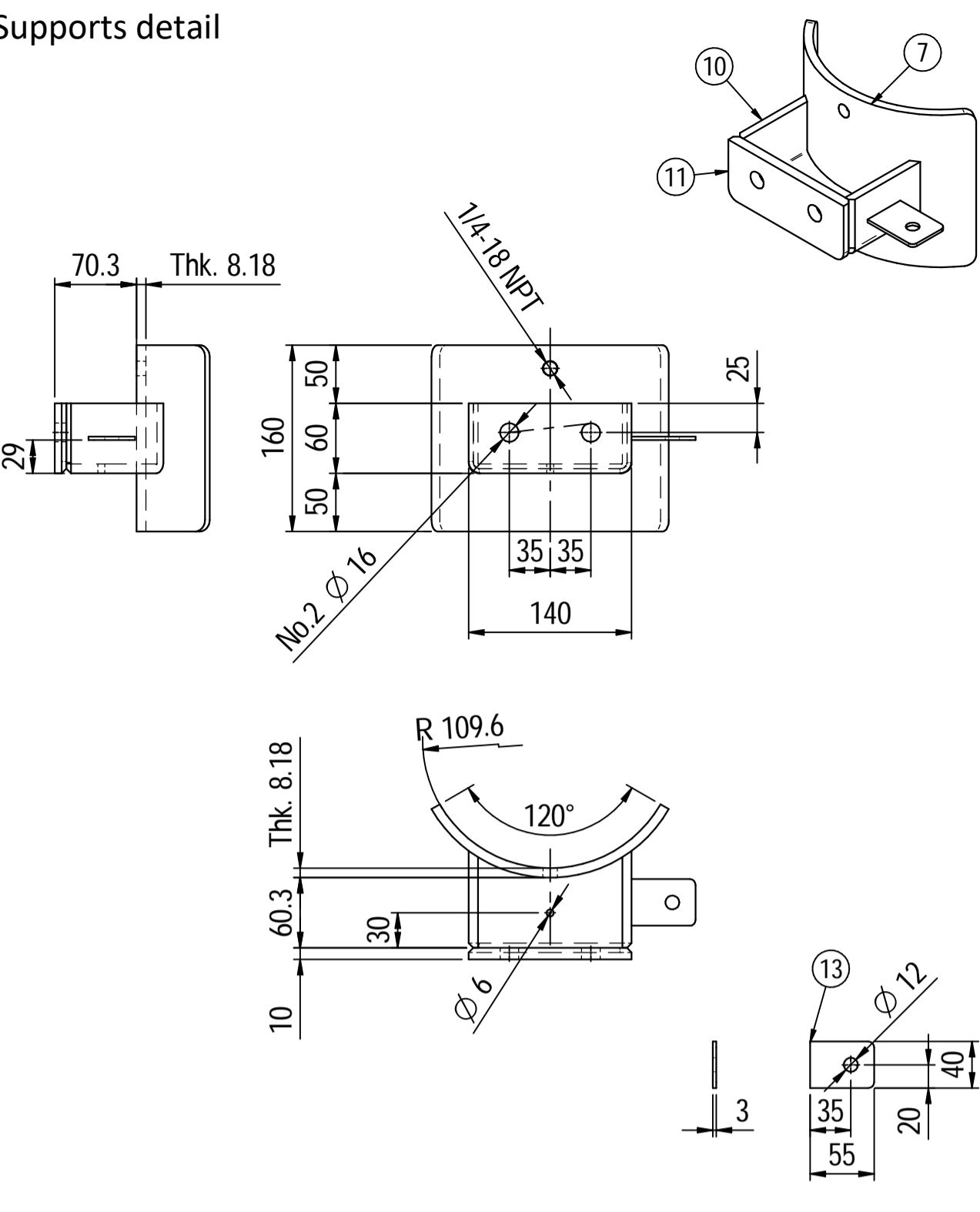

**Nameplate support detail scale 1:5**

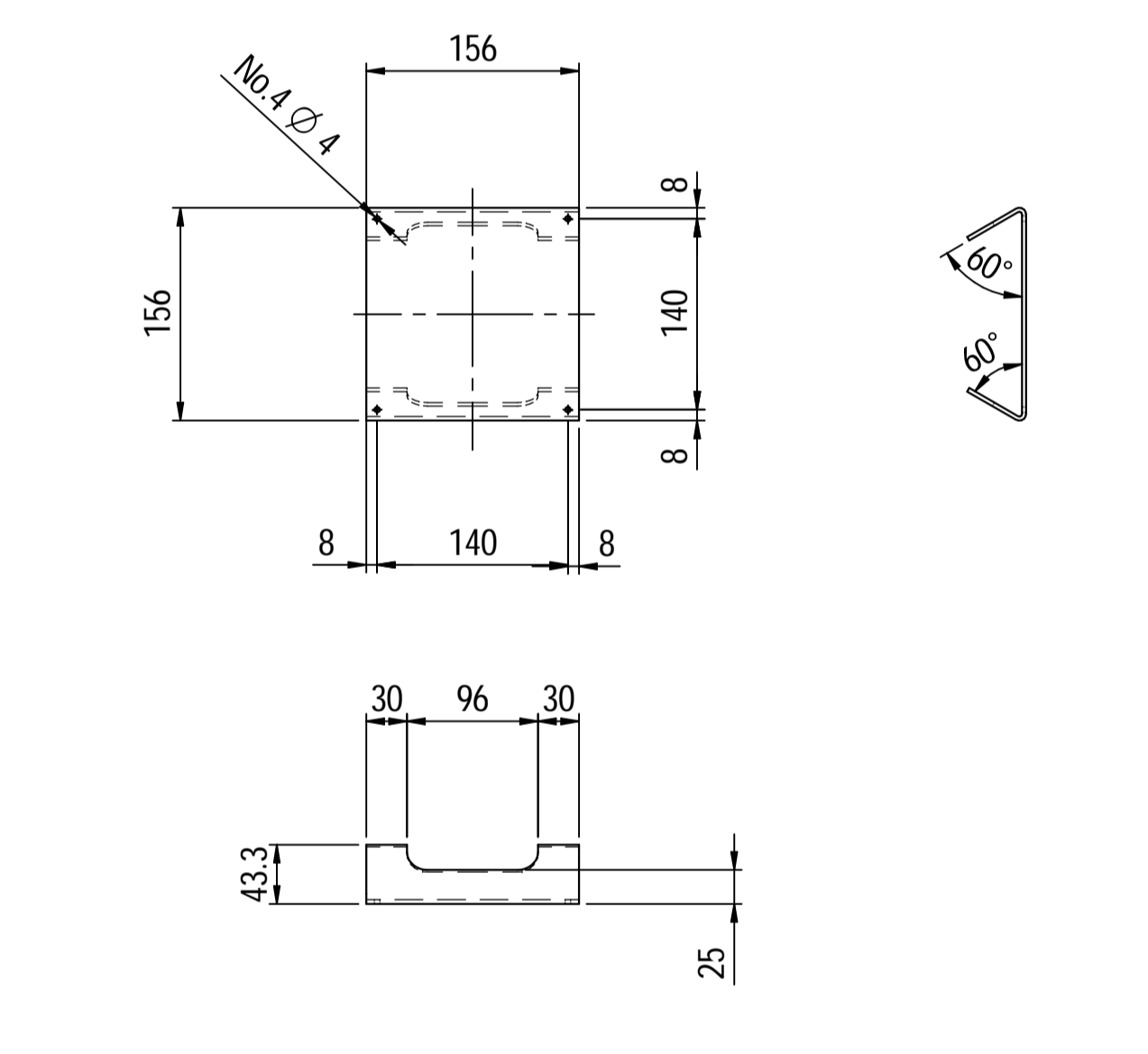

**Nameplate detail scale 1:2**

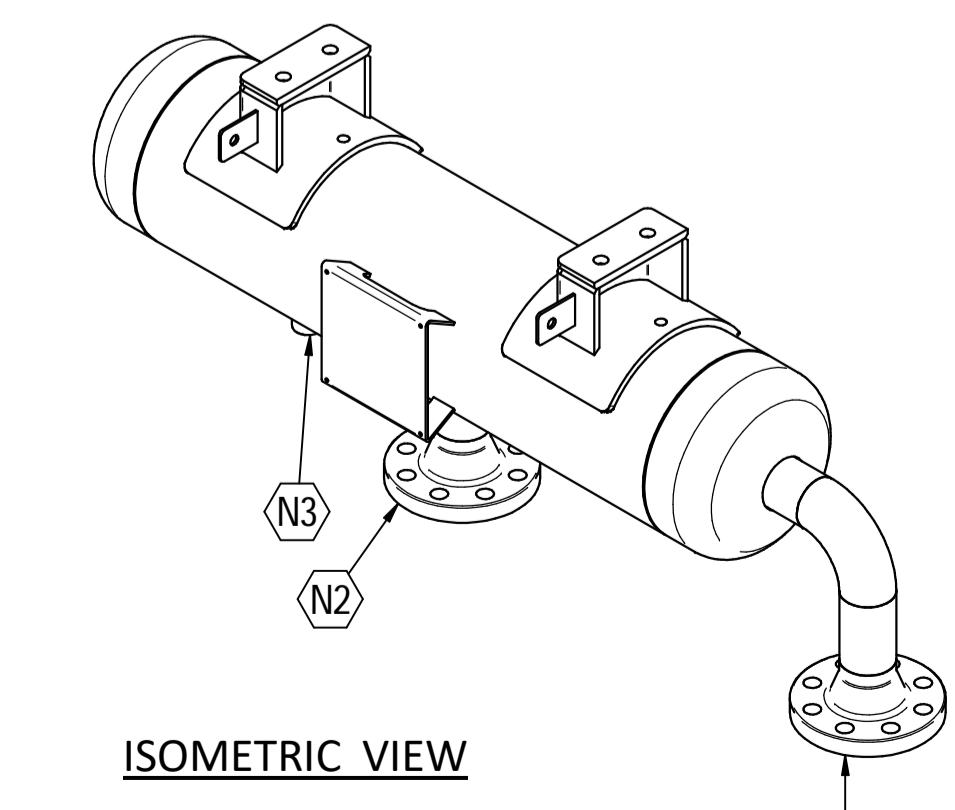
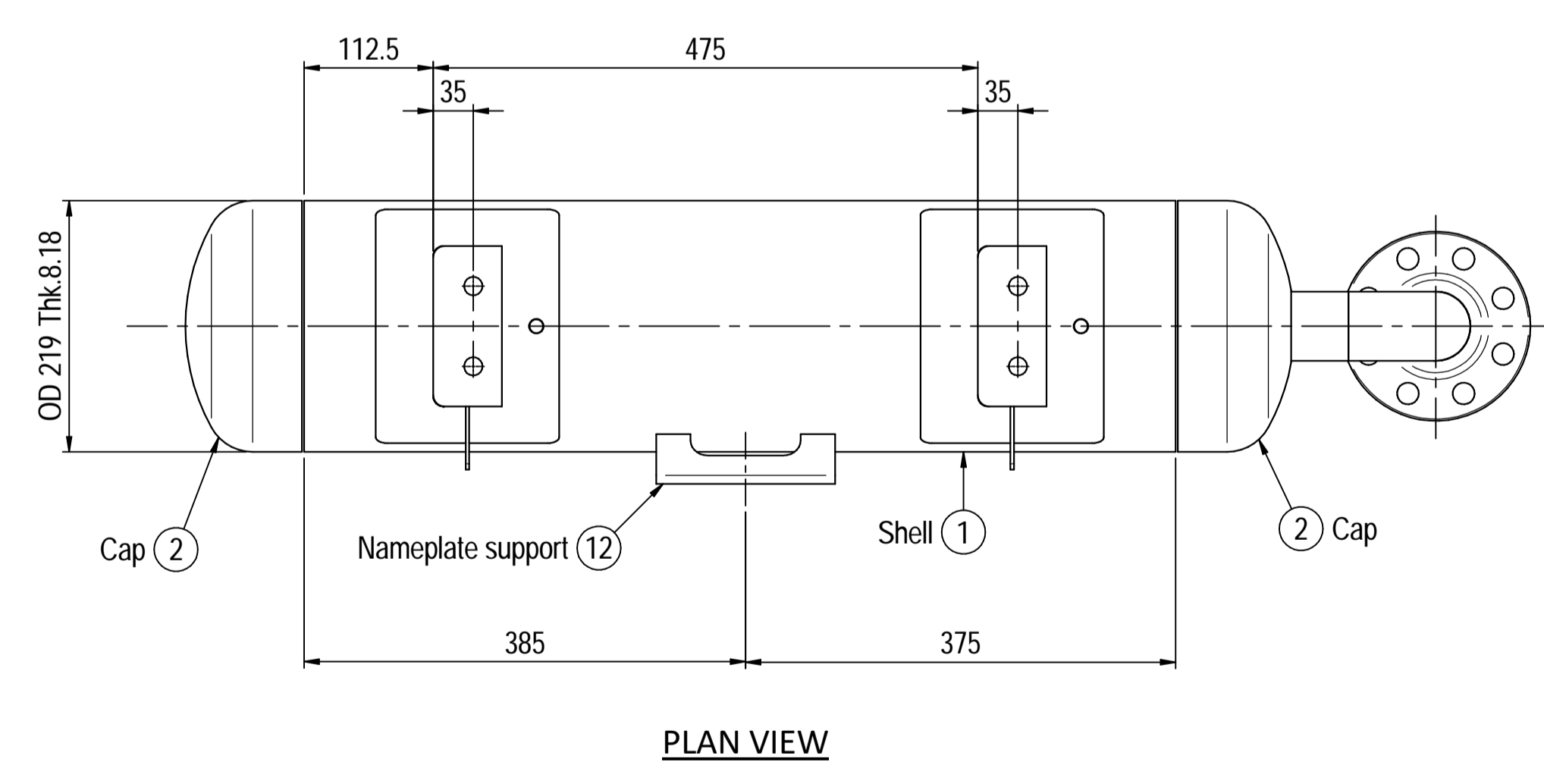
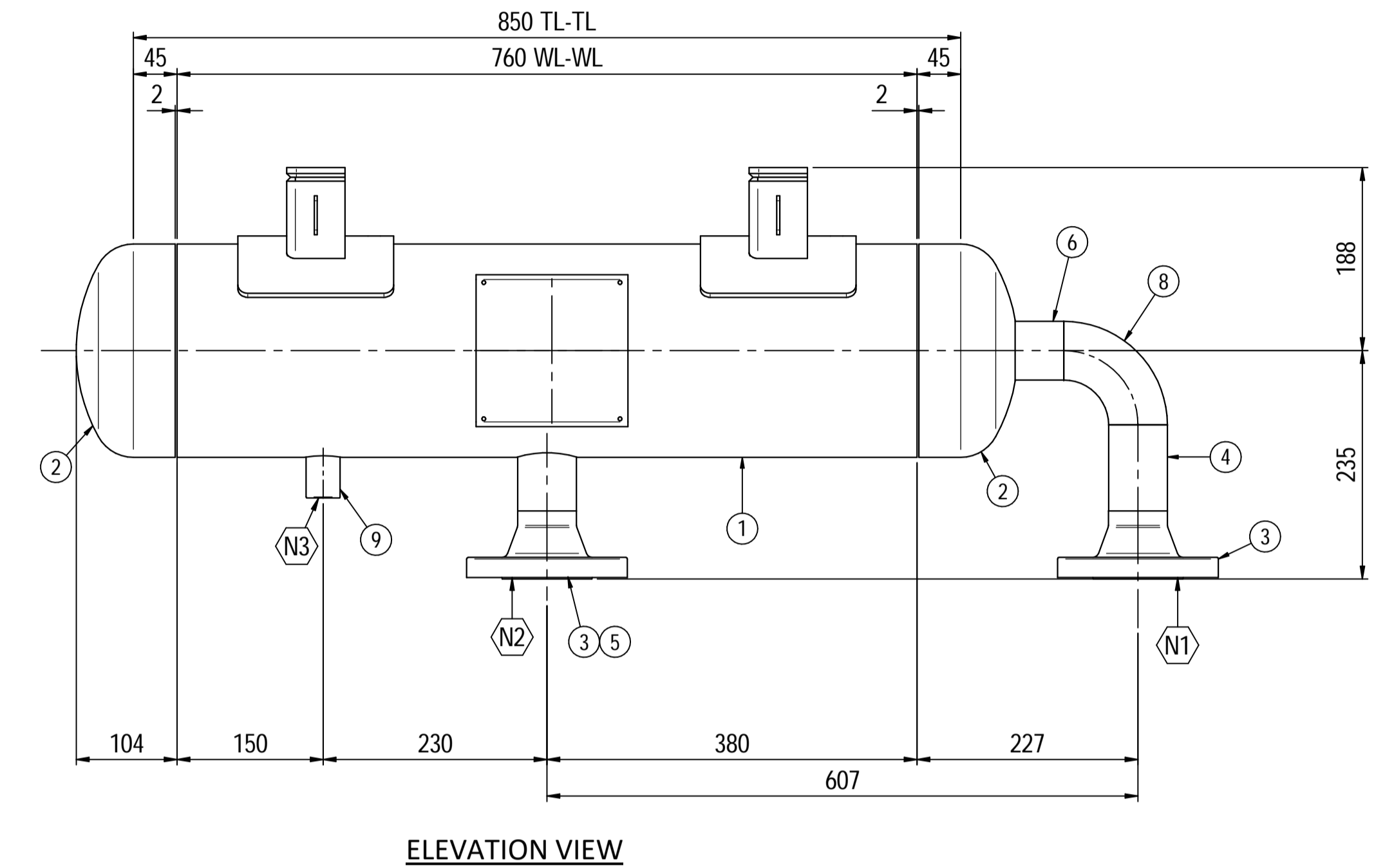
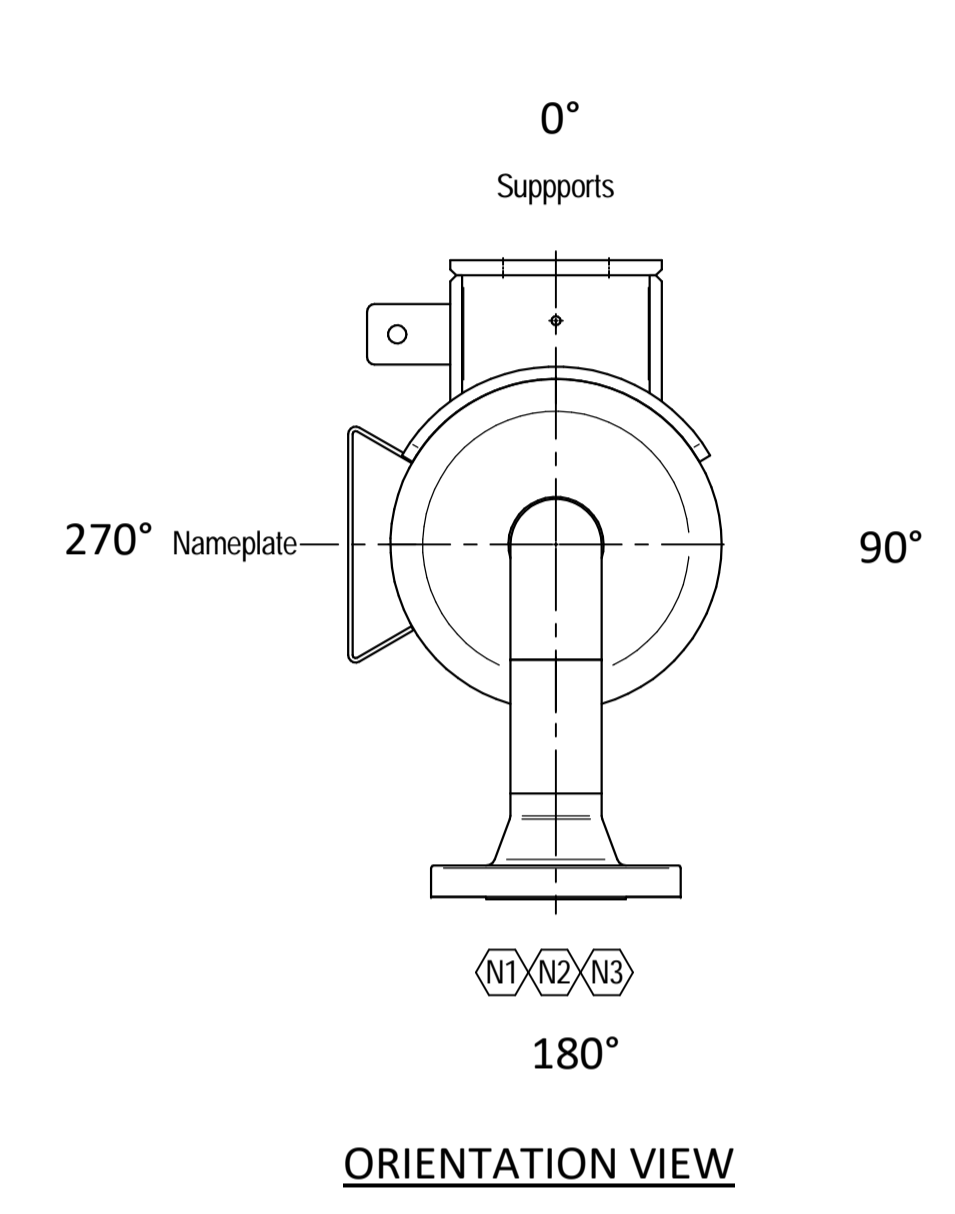
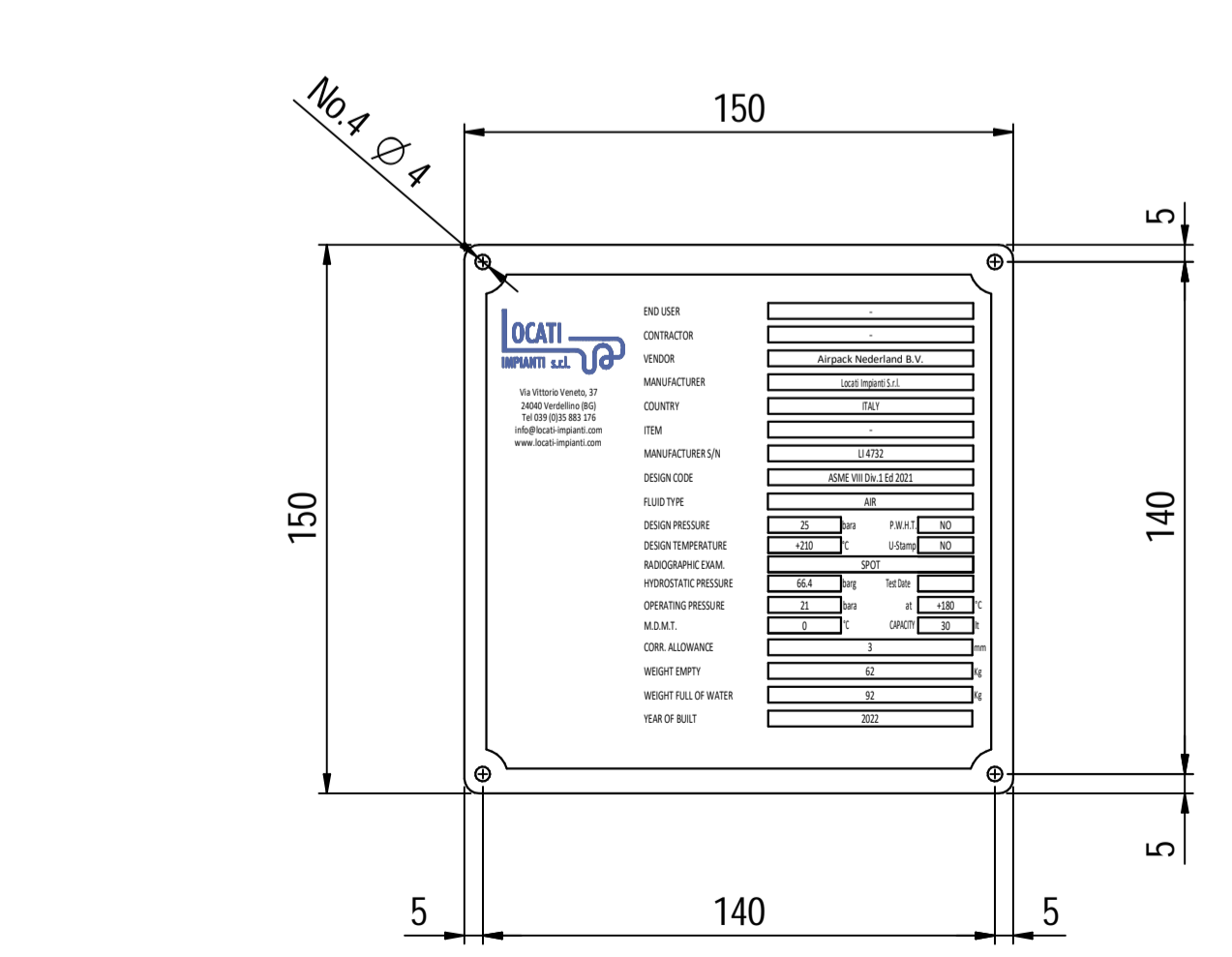

Material List				
Pos.	Q.ty	Description	Mat.	Cert.
1	1	Shell by seamless pipe 8" Sch.40 L=760	SA106 Gr.B	3.1
2	2	Cap 8" Sch40	A234 WPB	3.1
3	2	Flange 2" WN #300 RF Sch.160	A105	3.1
4	1	Seamless pipe 2" Sch160 L=88.5	A106 GrB	3.1
5	1	Seamless pipe 2" Sch160 L=74	A106 GrB	3.1
6	1	Seamless pipe 2" Sch160 L=63	A106 GrB	3.1
7	2	Pad by pipe 8" Sch.40	A106 Gr.B	3.1
8	1	Seamless elbow 2" 90° LR Sch.160	SA 234 WPB	3.1
9	1	Coupling 1/2" NPT #6000	A105	3.1
10	2	Plate 83x231 Thk.8	A516 70	3.1
11	2	Plate 60x140 Thk.10	A516 70	3.1
12	1	Nameplate support 156x241 Thk.3mm	A516 70	3.1
13	2	Earthing Plate 55 x 40 Thk.3	A240 TP316L	

- Note:**
- 1) Governing measurement S.I. unless otherwise specified;
  - 2) Flange bolt holes have to be straddled from main vessel center line in plan & vertical & horizontal centreline in elevation;
  - 3) Material: certification 3.1 EN 10204;
  - 4) All internal edge shall be rounded off;
  - 5) Nozzle fittings in accordance with ASME B16.5: 2013;
  - 6) Flange fittings in accordance with ASME B16.9: 2012;
  - 7) The flange dimensions are in accordance to ASME B16.5: 2013;
  - 8) All fillet welds not detailed on "WELDING MAP" or drawing shall have the weld; throated equal to 0,7 times the minimum thickness to be welded;
  - 9) All welds are continuous except where indicate;
  - 10) See document C220006CLC008 for vessel calculation.

ITEM	QTY	SERVICE	SIZE	O.D.	THK	RATING	TYPE	FACE	O.D.	THK.	Tc
N3	1	DRAIN	1/2"	38.1	8.38	#6000	-	NPT-F	-	-	8.5 + 10
N2	1	AIR OUTLET	2"	60.3	8.74	#300	WN	RF	-	-	8.5 + 10
N1	1	AIR INLET	2"	60.3	8.74	#300	WN	RF	-	-	8.5 + 10

DATI DI PROGETTO / Design data			
FLUIDO	Air	COLLAUDO	Test
STATO FISICO DEL FLUIDO	Gas	NATIONAL BOARD REGISTRATION	Lloyd register
Physical state of fluid	Gas		
CODICE DI CALCOLO	ASME VIII Div. 1 Ed.2021	CANADIAN REGISTER NUMBER	NO
Construction code			
PRESSIONE DI ESERCIZIO	21 bara	SERVIZIO LETALE	NO
Operating pressure		Lethal service	
PRESSIONE DI PROGETTO	(25 bara (24 barg))	X-RAY	RT examination
Design pressure			Spot (RT3)
PRESSIONE ESTERNA	NO	LIQUIDI PENETRANTI	NO
External pressure		Dye penetrant extension	
PRESSIONE DI PROVA IDRAULICA	66.4 barg	ULTRASUONI	NO
Hydraulic test pressure		Ultrasonic extension	
TEMPERATURA DI ESERCIZIO	+180°C	CONTROLLO MAGNETOSCOPICO	NO
Operating temperature		Magnetic particle examination	
TEMPERATURA DI PROGETTO	+210 °C	TALONE DI SALDATURA	NO
Design temperature		Weld tests coupon	
SOVRAMEATTO DI CORROSIONE	3 mm	PROCEDIMENTO DI SALDATURA	See doc: C220006WBK013
Corrosion allowance		Welding procedure	
CAPACITA'	30 l	TIPO DI FONDO	CAP
Capacity		Head type	
EFFICIENZA GIUNTI	0.85	FORMAZIONE FONDO	HOT
Joint efficiency		Head formid	
MAWP @ Design Temperature	38.66 barg @ +210°C	PESO A VUOTO	63 kg
		Empty weight	
MAWP(EXT)	NO	PESO IN ESERCIZIO	63 kg
		Operating weight	
MDMT @ MAWP	0 °C @ 38.66 barg	PESO PIENO D'ACQUA	92 kg
		Full water weight	
TRATTAMENTO TERMICO	NO	DATI DEL VENTO	-
		Wind datas	
P.W.H.T.			
IMPACT TEST	NO	DATI SISMICI	-
		Seismological datas	

Rev.	Descrizione / Description	Disegnato/Draw	Controllato/Checked	Approvato/Approved	Data/Date
05	Modified as per Client comments	CM	MV	GL	16/06/2022
04	Modified as per Client comments	CM	MV	GL	11/05/2022
03	Modified as per Client comments	CM	MV	GL	15/04/2022
02	Modified as per Customer comments	CM	MV	GL	02/04/2022
01	Modified earthing lug	CM	MV	GL	25/03/2022
00	FIRST ISSUE	CM	MV	GL	16/03/2022

Oggetto/Object: **PULSATION DAMPER OUTLET**

Scala/Scale	1 : 5	Formato/Size	A1
Comm. N°/Job No.	C220006	Foglio/Sheet	1 - 1
Cliente/Customer	Airpack Nederland B.V.		
Ord. No.	18498-VV-0901		
Dis. N°/Dwg No.	C220006DWG002	Rev.	05

LOCATI IMPIANTI s.r.l. logo and address: Via Vittoria Veneto, 37 24040 Verdello (BS) Italy - Tel: +39 (0)35 883 176 Fax: +39 (0)35 885 035 - e-mail: info@locatiimpianti.com