





OWNER:  شرکت سست و سویی توپو ایرانیاان (سهایی ناس)	BUSHEHR PETROCHEMICAL COMPANY MEG PLANT							EPC CONTRACTOR:  Chagalesh-Enerechimi-Steam Joint Venture BUPC-MEG PLANT PROJECT	
	LOGIC DIAGRAMS-PROGRAM OF UCP - COMPRESSOR SHUTDOWN LOGIC DRAWING FOR EMERGENCY INSTRUMENT AIR COMPRESSOR							 Netherlands	
MC :  شرکت سست و سویی توپو ایرانیاان (سهایی ناس)								Project	Area
Owner Document Number: 17811-32B	BU	20	VD	303	IN	DIG	0085	Rev.:	Page
								04	1 of 16

LOGIC DIAGRAMS-PROGRAM OF UCP - COMPRESSOR SHUTDOWN LOGIC DRAWING FOR EMERGENCY INSTRUMENT AIR COMPRESSOR

04	05/07/2022	Approved for Construction	RT	KP	JR	
04	17/05/2022	Approved for Construction	AZ	KP	JR	
03	18/03/2022	Approved for Construction	AS	KP	JR	
02	06/01/2022	Approved for Construction	AS	KP	JR	
01	30/11/2021	For approval	WZ	KP	JR	
00	24/11/2020	For approval	TJ	RB	JR	
Rev.	Date	Purpose of Issue	Prepared	Checked	Approved	AC Code
					Class: 1	Phase: P

SYMBOL	FUNCTION	DESCRIPTION
	AND	OUTPUT D EXISTS ONLY IF AND WHILE INPUTS A,B AND C EXIST.
	OR	OUTPUT D EXISTS ONLY IF AND WHILE ONE OR MORE OF INPUTS A,B OR C EXIST.
	XOR	OUTPUT D EXISTS ONLY IF AND WHILE ONE OF INPUTS A,B OR C EXIST.
	NOT	OUTPUT B EXISTS ONLY IF AND WHILE INPUT A DOES NOT EXIST.
	TIMER (DELAY INITIATION)	THE CONTINUOUS EXISTENCE OF INPUT A FOR TIME T CAUSES OUTPUT B TO EXIST WHEN THE TIME T EXPIRES. B TERMINATES IMMEDIATELY WHEN A TERMINATES.
	TIMER (DELAY TERMINATION)	THE EXISTENCE OF INPUT A CAUSES OUTPUT B TO EXIST IMMEDIATELY. B TERMINATES WHEN A HAS TERMINATED AND HAS NOT AGAIN EXISTED FOR TIME T.
	PULSE OUTPUT	THE EXISTENCE OF INPUT A CAUSES OUTPUT B TO EXIST IMMEDIATELY. B EXISTS FOR TIME T, REGARDLESS OF THE STATE OF A.
	FLIP-FLOP MEMORY (SET PRIORITY)	OUTPUT C EXISTS AS SOON AS A EXISTS. C CONTINUES TO EXIST, REGARDLESS OF THE SUBSEQUENT STATE OF A, UNTIL THE MEMORY IS RESET (I.E; TERMINATED BY B EXISTING) C REMAINS TERMINATED, REGARDLESS OF THE SUBSEQUENT STATE OF B, UNTIL A CAUSES THE MEMORY TO BE SET. IF A AND B EXIST SIMULTANEOUSLY, A OVERRIDES B.
	FLIP-FLOP MEMORY (RESET PRIORITY)	OUTPUT C EXISTS AS SOON AS A EXISTS. C CONTINUES TO EXIST, REGARDLESS OF THE SUBSEQUENT STATE OF A, UNTIL THE MEMORY IS RESET (I.E; TERMINATED BY B EXISTING) C REMAINS TERMINATED, REGARDLESS OF THE SUBSEQUENT STATE OF B, UNTIL A CAUSES THE MEMORY TO BE SET. IF A AND B EXIST SIMULTANEOUSLY, B OVERRIDES A.
		LOGIC CONNECTION
		NO CONNECTION
		SERIAL LINK / FOUNDATION FIELDBUS PROTOCOL

SYMBOL	DESCRIPTION
	EMERGENCY PUSHBUTTON, RED HEAD, STAY PUT.
	TOGGLE SWITCH
	PUSHBUTTON MOMENTARILY MAKE
	PUSHBUTTON MOMENTARILY BREAK
	CONTACT NORMALLY OPEN
	CONTACT NORMALLY CLOSED
	HARDWIRED INPUT/OUTPUT
	SOLENOID VALVE, 3-WAY
	DISTRIBUTED CONTROL SYSTEM
	PLC CONTROL SYSTEM
	DCS AUXILIARY CONSOLE
	LAMP
	HMI
	AUDIBLE ALARM
	RELAY COIL

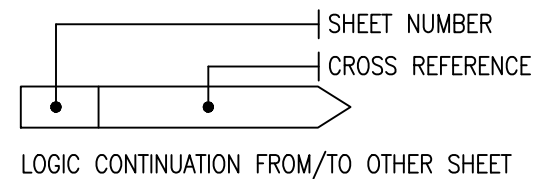

ABBREVIATIONS

DCS : DISTRIBUTED CONTROL SYSTEM
 UCP : UNIT CONTROL PANEL
 LCP : LOCAL CONTROL PANEL
 PLC : PROGRAMMABLE LOGIC CONTROLLER
 I/P : INPUT
 O/P : OUTPUT
 ESD : EMERGENCY SHUTDOWN
 MCC : MOTOR CONTROL CENTRE

GENERAL NOTES

- SHUTDOWN CONDITION ;
0 = SHUTDOWN 1 = OPERATING
- ALARM/TRIP CONDITION ;
0 = ALARM 1=NORMAL
0 = TRIP 1=NORMAL
- REMOTE/LOCAL CONDITION ;
0 = LOCAL 1=REMOTE



SUBJECT	BUSHEHR PETROCHEMICAL COMPANY MEG PLANT EMERGENCY INSTRUMENT AIR COMPRESSOR	DATE	20-11-2020
CLIENT	BUSHEHR PETROCHEMICAL COMPANY (BUPC)	DRAWN BY	TJ
CLIENT REF	20-C-7080	CHECKED BY	KP
AIRPACK REF	17811	PLANT LOCATION	IRAN
		DRAWING NO.	17811-32B
		SHEETNO.	01 /14

THIS DRAWING IS OWNED BY AIRPACK AND SHALL NOT BE PRINTED OR COPIED IN ANY OTHER WAY THAN WITH AIRPACKS PERMISSION		
REV 05	04-07-2022	RT
REV 04	16-05-2022	WZ
REV 03	18-03-2022	AS
REV02	03-01-2022	AS
REV 01	29-11-2021	WZ
REV 00	20-11-2020	TJ

LOGIC DIAGRAM

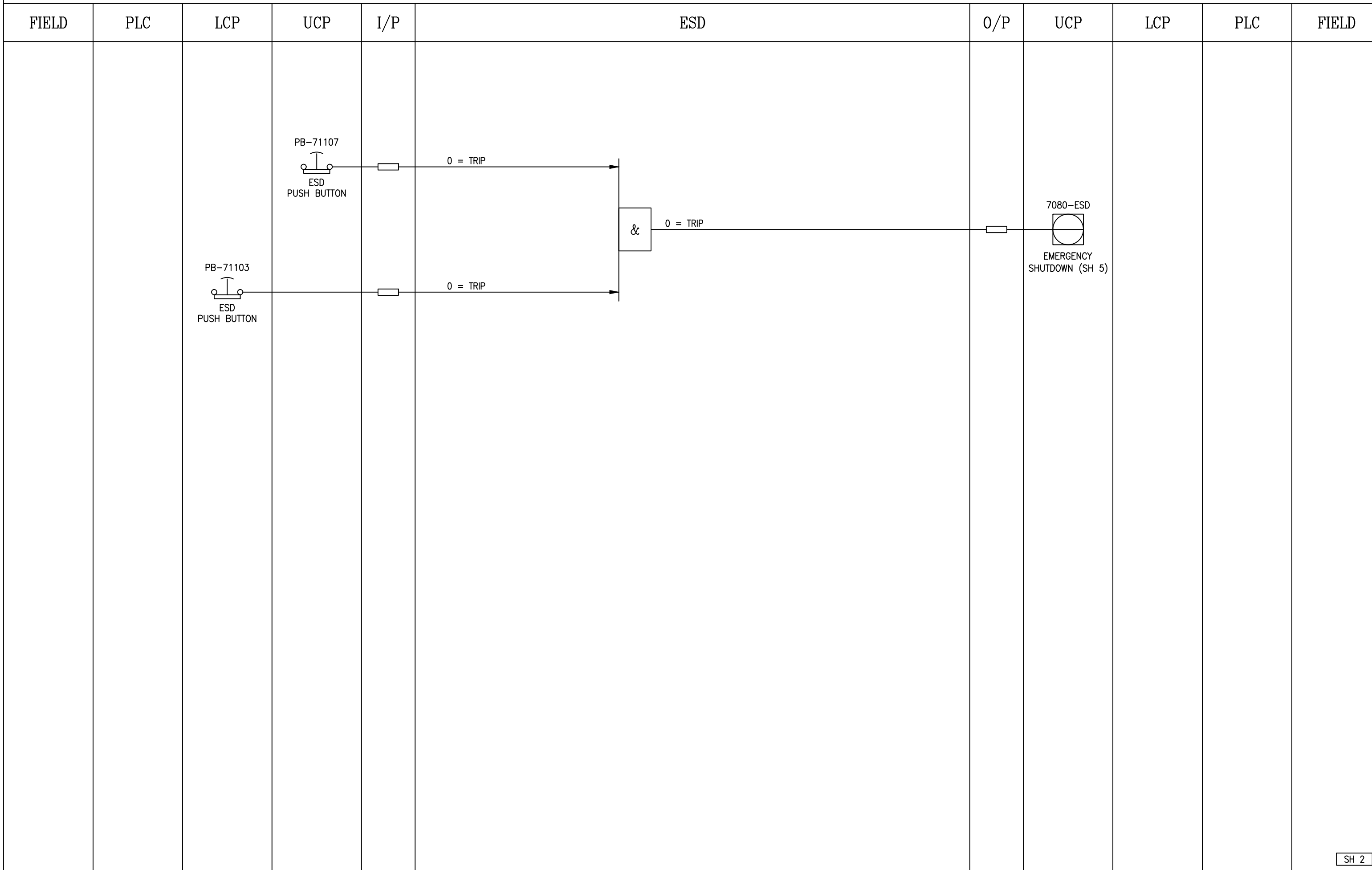

SH 2

NOTES:

	SUBJECT BUSHEHR PETROCHEMICAL COMPANY MEG PLANT EMERGENCY INSTRUMENT AIR COMPRESSOR		DATE	20-11-2020	THIS DRAWING IS OWNED BY AIRPACK AND SHALL NOT BE PRINTED OR COPIED IN ANY OTHER WAY THAN WITH AIRPACKS PERMISSION
			DRAWN BY	TJ	
			CHECKED BY	KP	
	CLIENT	BUSHEHR PETROCHEMICAL COMPANY (BUPC)	PLANT LOCATION	IRAN	
	CLIENT REF	20-C-7080	DRAWING NO.	17811-32B	
AIRPACK REF	17811	SHEETNO.	02 / 14		
			REV 05	04-07-2022	RT
			REV 04	16-05-2022	WZ
			REV 03	18-03-2022	AS
			REV02	03-01-2022	AS
			REV 01	29-11-2021	WZ
			REV 00	20-11-2020	TJ

LOGIC DIAGRAM

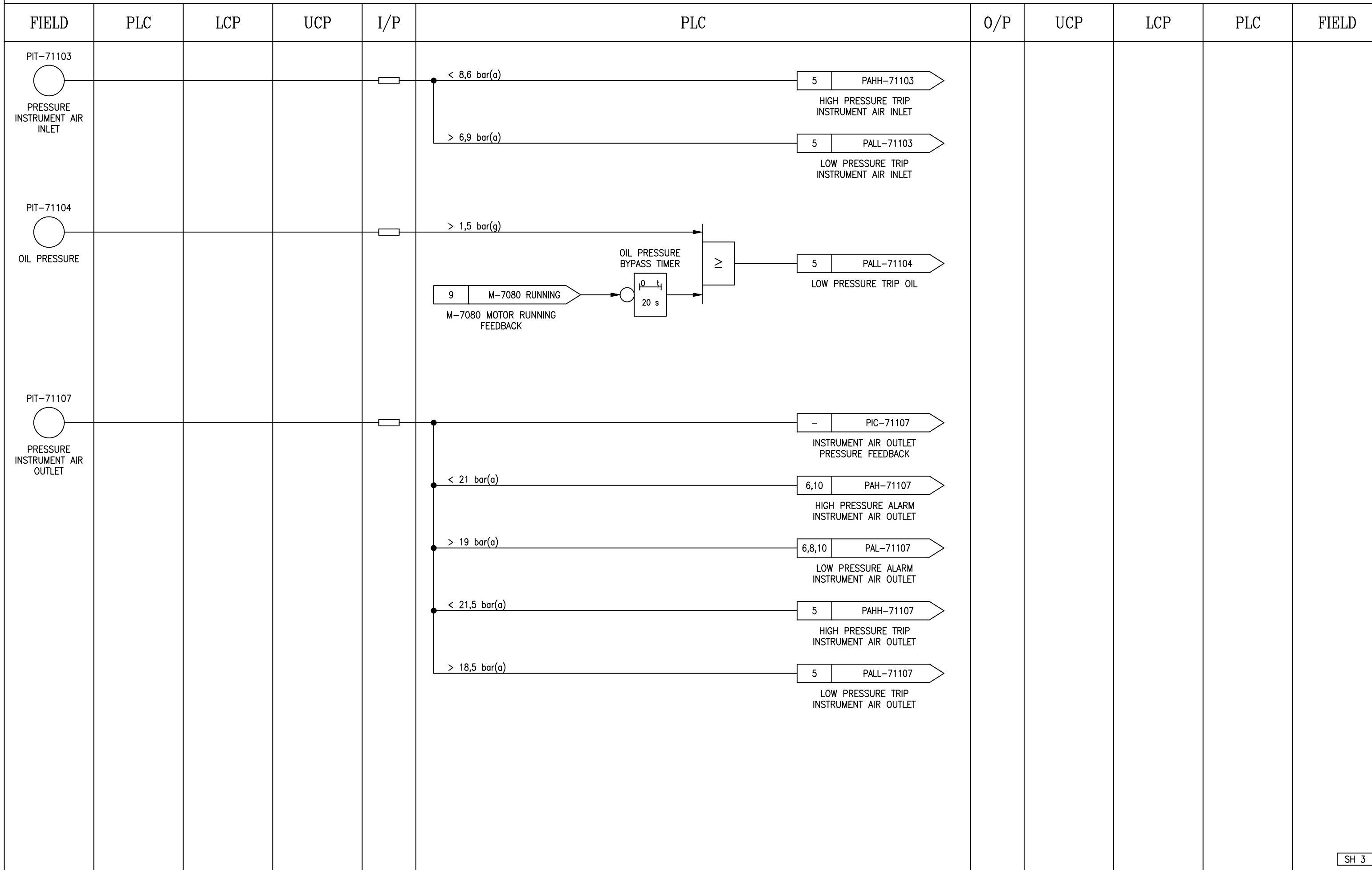

SH 3

NOTES:

	SUBJECT BUSHEHR PETROCHEMICAL COMPANY MEG PLANT EMERGENCY INSTRUMENT AIR COMPRESSOR		DATE 20-11-2020	THIS DRAWING IS OWNED BY AIRPACK AND SHALL NOT BE PRINTED OR COPIED IN ANY OTHER WAY THAN WITH AIRPACKS PERMISSION
			DRAWN BY TJ	
			CHECKED BY KP	
	CLIENT BUSHEHR PETROCHEMICAL COMPANY (BUPC)	PLANT LOCATION IRAN		
	CLIENT REF 20-C-7080	DRAWING NO. 17811-32B		
AIRPACK REF 17811	SHEETNO. 03 / 14			
				REV 05 04-07-2022 RT
				REV 04 16-05-2022 WZ
				REV 03 18-03-2022 AS
				REV 02 03-01-2022 AS
				REV 01 29-11-2021 WZ
				REV 00 20-11-2020 TJ

LOGIC DIAGRAM

FIELD	PLC	LCP	UCP	I/P	PLC	O/P	UCP	LCP	PLC	FIELD
TIT-71101 TEMPERATURE INSTRUMENT AIR INLET					< 56 °C	6 TAH-71101 HIGH TEMPERATURE ALARM INSTRUMENT AIR INLET				
TIT-71102 TEMPERATURE COMPRESSOR UPSTREAM AFTER-COOLER					< 195 °C	5 TAHH-71102 HIGH TEMPERATURE TRIP TEMPERATURE COMPRESSOR UPSTREAM AFTER-COOLER				
VT-71101 VIBRATION SENSOR COMPRESSOR BLOCK					< 8 mm/sec	5 VAHH-71101 HIGH VIBRATION TRIP COMPRESSOR BLOCK				
FT-71101 FLOW TRANSMITTER COMPRESSOR OUTLET					> 2,3 m ³ /hr	6 FAL-71101 LOW FLOW ALARM COMPRESSOR OUTLET				

SH 4

NOTES:



SUBJECT		BUSHEHR PETROCHEMICAL COMPANY MEG PLANT EMERGENCY INSTRUMENT AIR COMPRESSOR	
CLIENT	BUSHEHR PETROCHEMICAL COMPANY (BUPC)	PLANT LOCATION	IRAN
CLIENT REF	20-C-7080	DRAWING NO.	17811-32B
AIRPACK REF	17811	SHEETNO.	04 / 14

DATE	20-11-2020
DRAWN BY	TJ
CHECKED BY	KP

THIS DRAWING IS OWNED BY AIRPACK AND SHALL NOT BE PRINTED OR COPIED IN ANY OTHER WAY THAN WITH AIRPACKS PERMISSION		
REV 05	04-07-2022	RT
REV 04	16-05-2022	WZ
REV 03	18-03-2022	AS
REV 02	03-01-2022	AS
REV 01	29-11-2021	WZ
REV 00	20-11-2020	TJ

LOGIC DIAGRAM

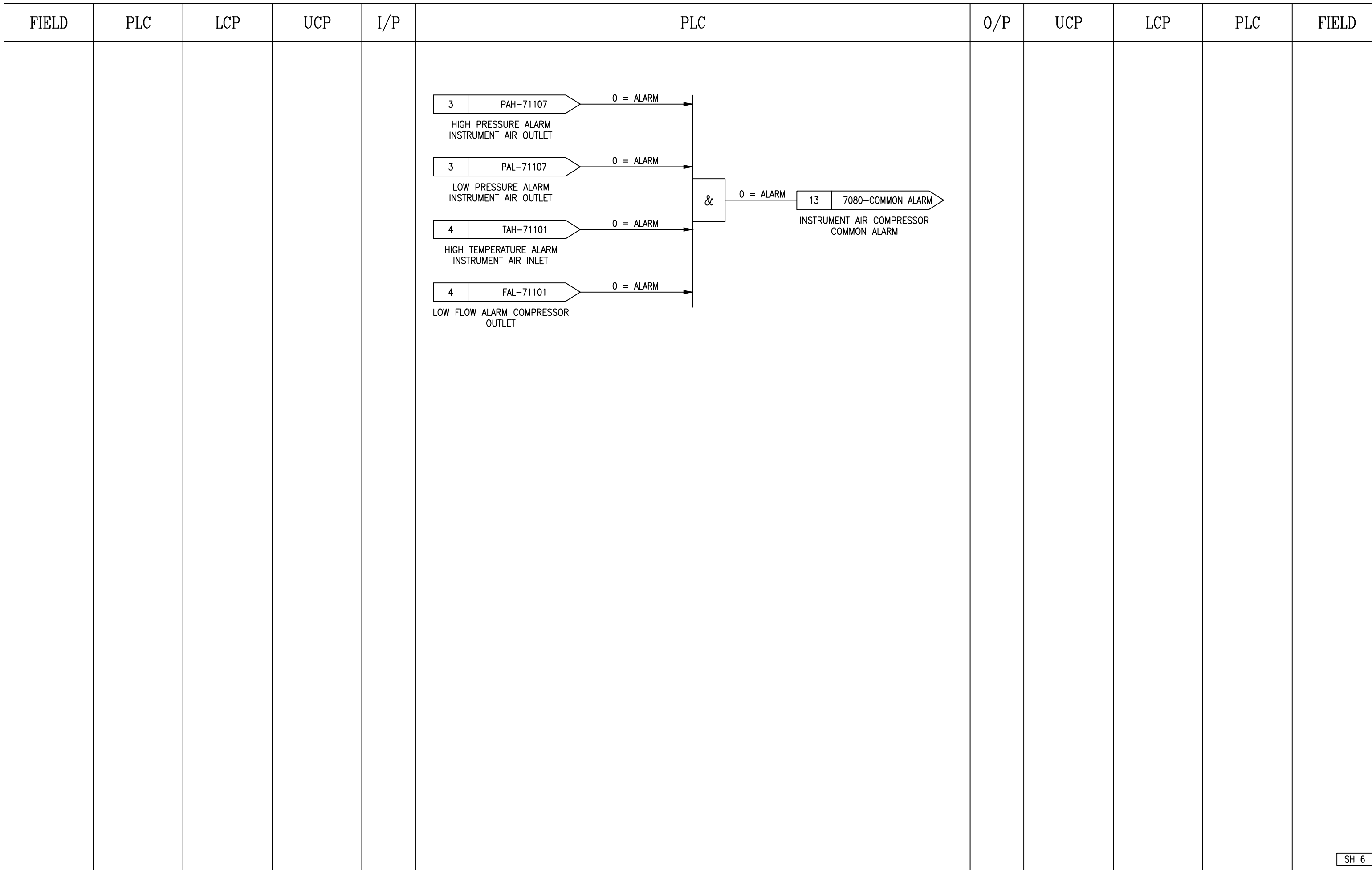

NOTES:

	SUBJECT BUSHEHR PETROCHEMICAL COMPANY MEG PLANT EMERGENCY INSTRUMENT AIR COMPRESSOR		DATE 20-11-2020	THIS DRAWING IS OWNED BY AIRPACK AND SHALL NOT BE PRINTED OR COPIED IN ANY OTHER WAY THAN WITH AIRPACKS PERMISSION
			DRAWN BY TJ	
			CHECKED BY KP	
	CLIENT BUSHEHR PETROCHEMICAL COMPANY (BUPC)	PLANT LOCATION IRAN		
	CLIENT REF 20-C-7080	DRAWING NO. 17811-32B		
AIRPACK REF 17811	SHEETNO. 06 /14	DATE 20-11-2020	REV 05 04-07-2022 RT	
		DATE 16-05-2022	REV 04 16-05-2022 WZ	
		DATE 18-03-2022	REV 03 18-03-2022 AS	
		DATE 03-01-2022	REV02 03-01-2022 AS	
		DATE 29-11-2021	REV 01 29-11-2021 WZ	
		DATE 20-11-2020	REV 00 20-11-2020 TJ	

LOGIC DIAGRAM

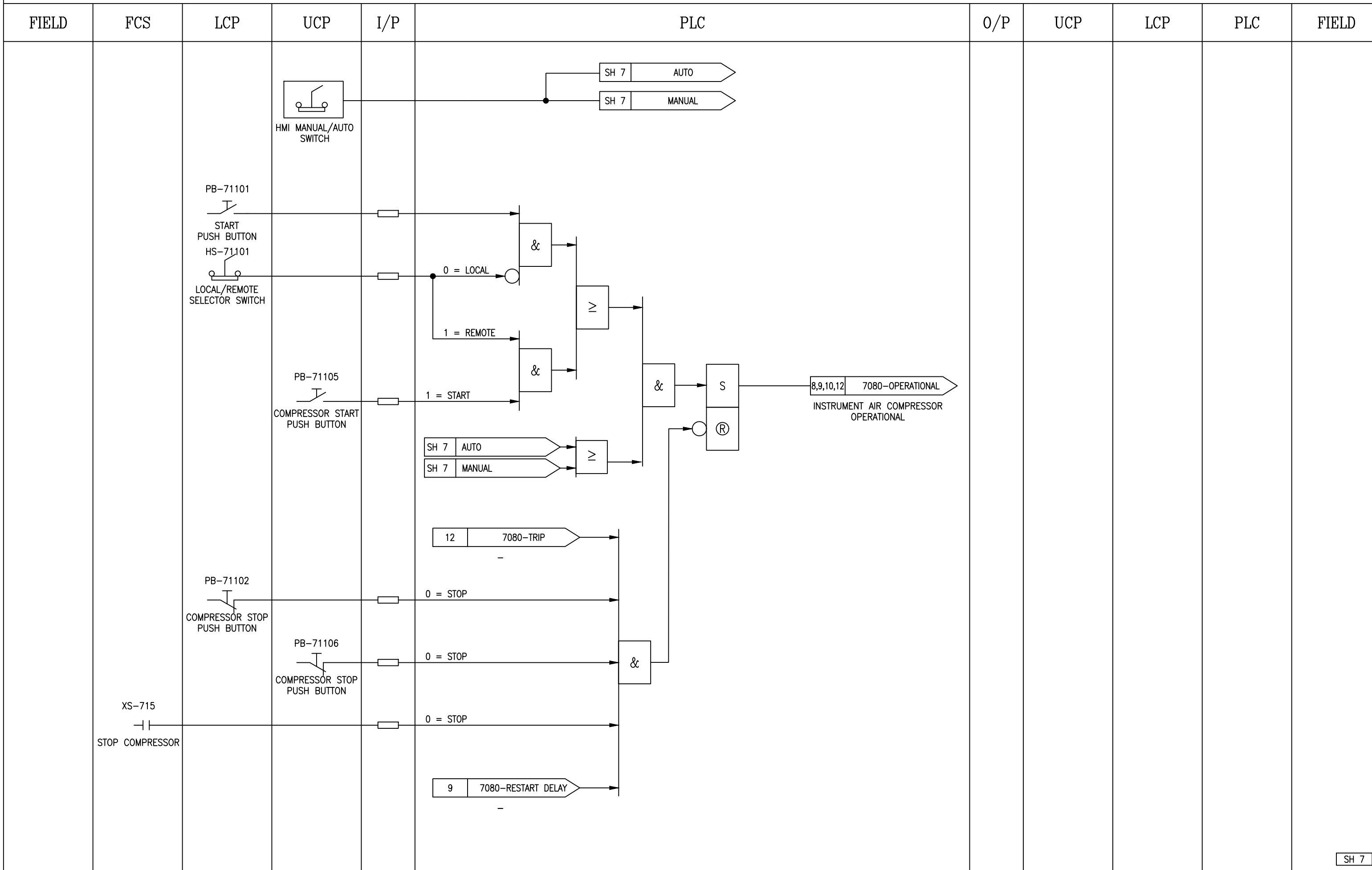

SH 7

NOTES:

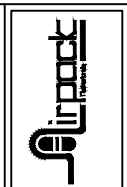

SUBJECT		BUSHEHR PETROCHEMICAL COMPANY MEG PLANT EMERGENCY INSTRUMENT AIR COMPRESSOR	
CLIENT	BUSHEHR PETROCHEMICAL COMPANY (BUPC)	PLANT LOCATION	IRAN
CLIENT REF	20-C-7080	DRAWING NO.	17811-32B
AIRPACK REF	17811	SHEETNO.	07 / 14

DATE	20-11-2020
DRAWN BY	TJ
CHECKED BY	KP

THIS DRAWING IS OWNED BY AIRPACK AND SHALL NOT BE PRINTED OR COPIED IN ANY OTHER WAY THAN WITH AIRPACKS PERMISSION		
REV 05	04-07-2022	RT
REV 04	16-05-2022	WZ
REV 03	18-03-2022	AS
REV 02	03-01-2022	AS
REV 01	29-11-2021	WZ
REV 00	20-11-2020	TJ

LOGIC DIAGRAM

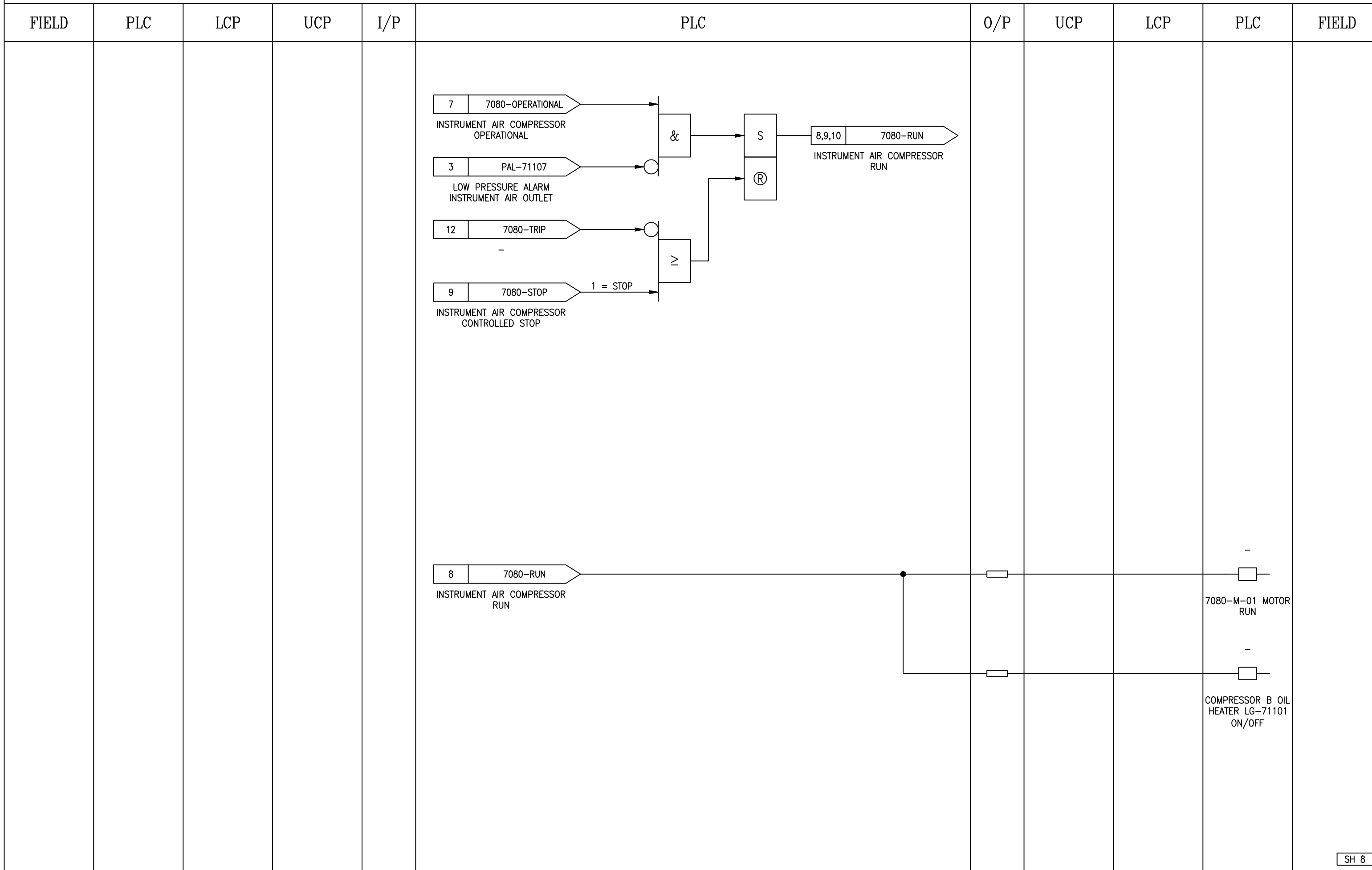

SH 8

NOTES:

	SUBJECT BUSHEHR PETROCHEMICAL COMPANY MEG PLANT EMERGENCY INSTRUMENT AIR COMPRESSOR		DATE 20-11-2020	THIS DRAWING IS OWNED BY AIRPACK AND SHALL NOT BE PRINTED OR COPIED IN ANY OTHER WAY THAN WITH AIRPACKS PERMISSION
	CLIENT BUSHEHR PETROCHEMICAL COMPANY (BUPC)	PLANT LOCATION IRAN	DRAWN BY TJ	
	CLIENT REF 20-C-7080	DRAWING NO. 17811-32B	CHECKED BY KP	
	AIRPACK REF 17811	SHEETNO. 08 / 14	REV 05 04-07-2022 RT	
			REV 04 16-05-2022 WZ	
		REV 03 18-03-2022 AS		
		REV 02 03-01-2022 AS		
		REV 01 29-11-2021 WZ		
		REV 00 20-11-2020 TJ		

LOGIC DIAGRAM

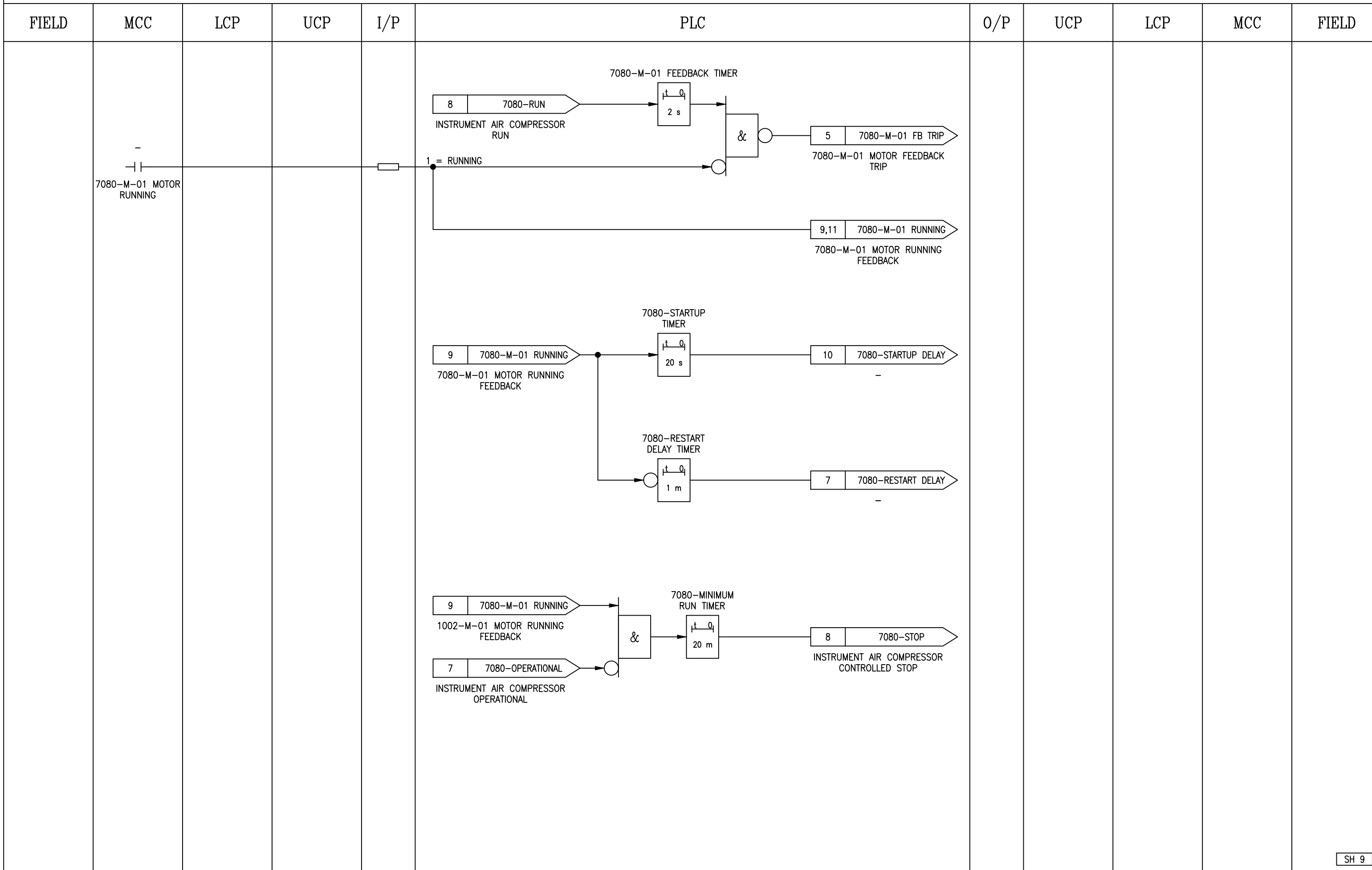

SH 9

NOTES:

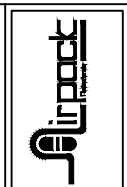

SUBJECT		BUSHEHR PETROCHEMICAL COMPANY MEG PLANT EMERGENCY INSTRUMENT AIR COMPRESSOR	
CLIENT	BUSHEHR PETROCHEMICAL COMPANY (BUPC)	PLANT LOCATION	IRAN
CLIENT REF	20-C-7080	DRAWING NO.	17811-32B
AIRPACK REF	17811	SHEETNO.	09 /14

DATE	20-11-2020
DRAWN BY	TJ
CHECKED BY	KP

THIS DRAWING IS OWNED BY AIRPACK AND SHALL NOT BE PRINTED OR COPIED IN ANY OTHER WAY THAN WITH AIRPACKS PERMISSION					
			REV 05	04-07-2022	RT
			REV 04	16-05-2022	WZ
			REV 03	18-03-2022	AS
			REV02	03-01-2022	AS
			REV 01	29-11-2021	WZ
REV 00	20-11-2020	TJ			

LOGIC DIAGRAM

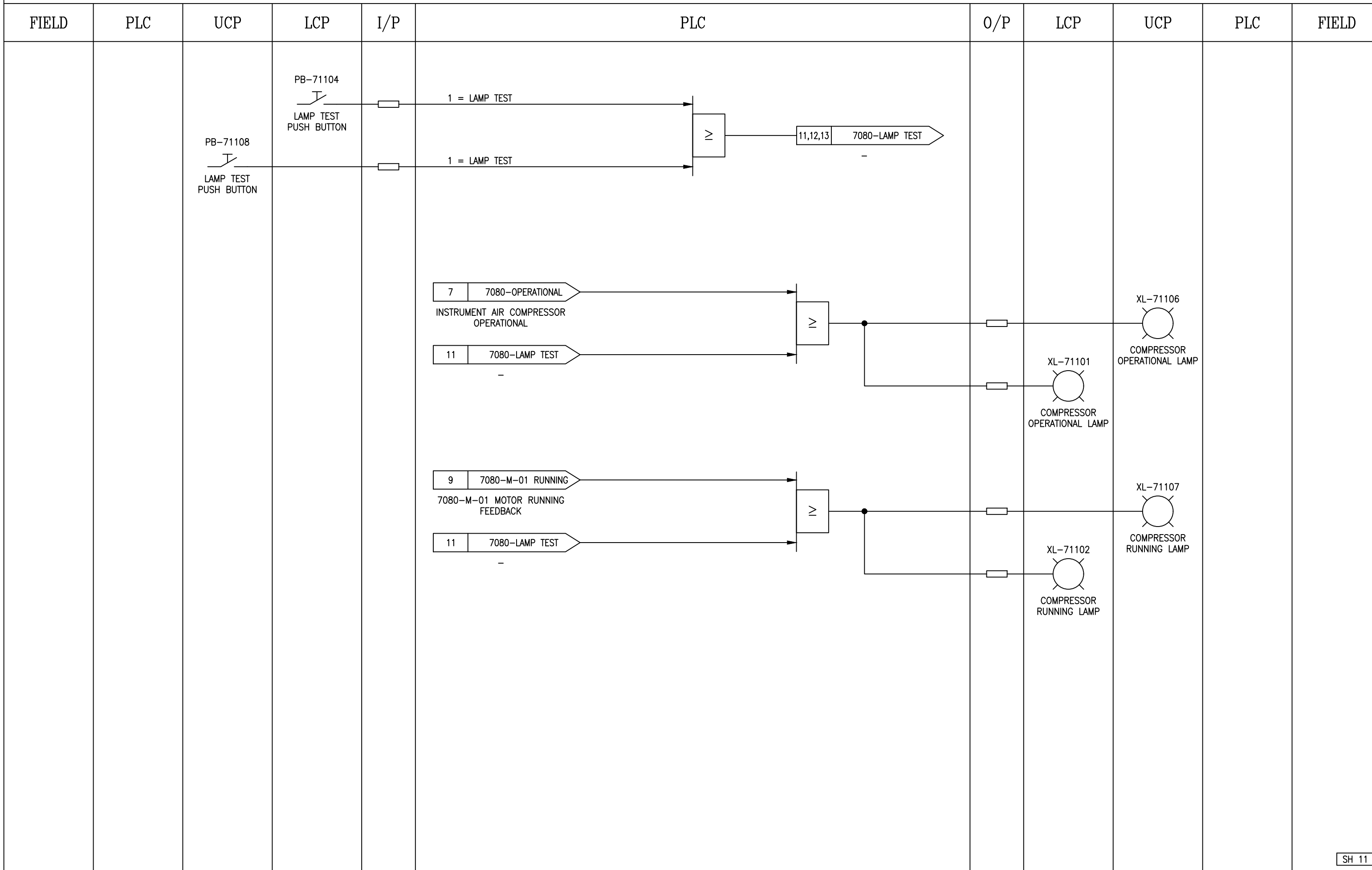

SH 11

NOTES:

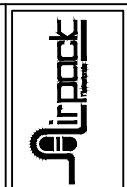

SUBJECT		BUSHEHR PETROCHEMICAL COMPANY MEG PLANT EMERGENCY INSTRUMENT AIR COMPRESSOR	
CLIENT	BUSHEHR PETROCHEMICAL COMPANY (BUPC)	PLANT LOCATION	IRAN
CLIENT REF	20-C-7080	DRAWING NO.	17811-32B
AIRPACK REF	17811	SHEETNO.	11 /14

DATE	20-11-2020
DRAWN BY	TJ
CHECKED BY	KP

THIS DRAWING IS OWNED BY AIRPACK AND SHALL NOT BE PRINTED OR COPIED IN ANY OTHER WAY THAN WITH AIRPACKS PERMISSION		
REV 05	04-07-2022	RT
REV 04	16-05-2022	WZ
REV 03	18-03-2022	AS
REV02	03-01-2022	AS
REV 01	29-11-2021	WZ
REV 00	20-11-2020	TJ

LOGIC DIAGRAM

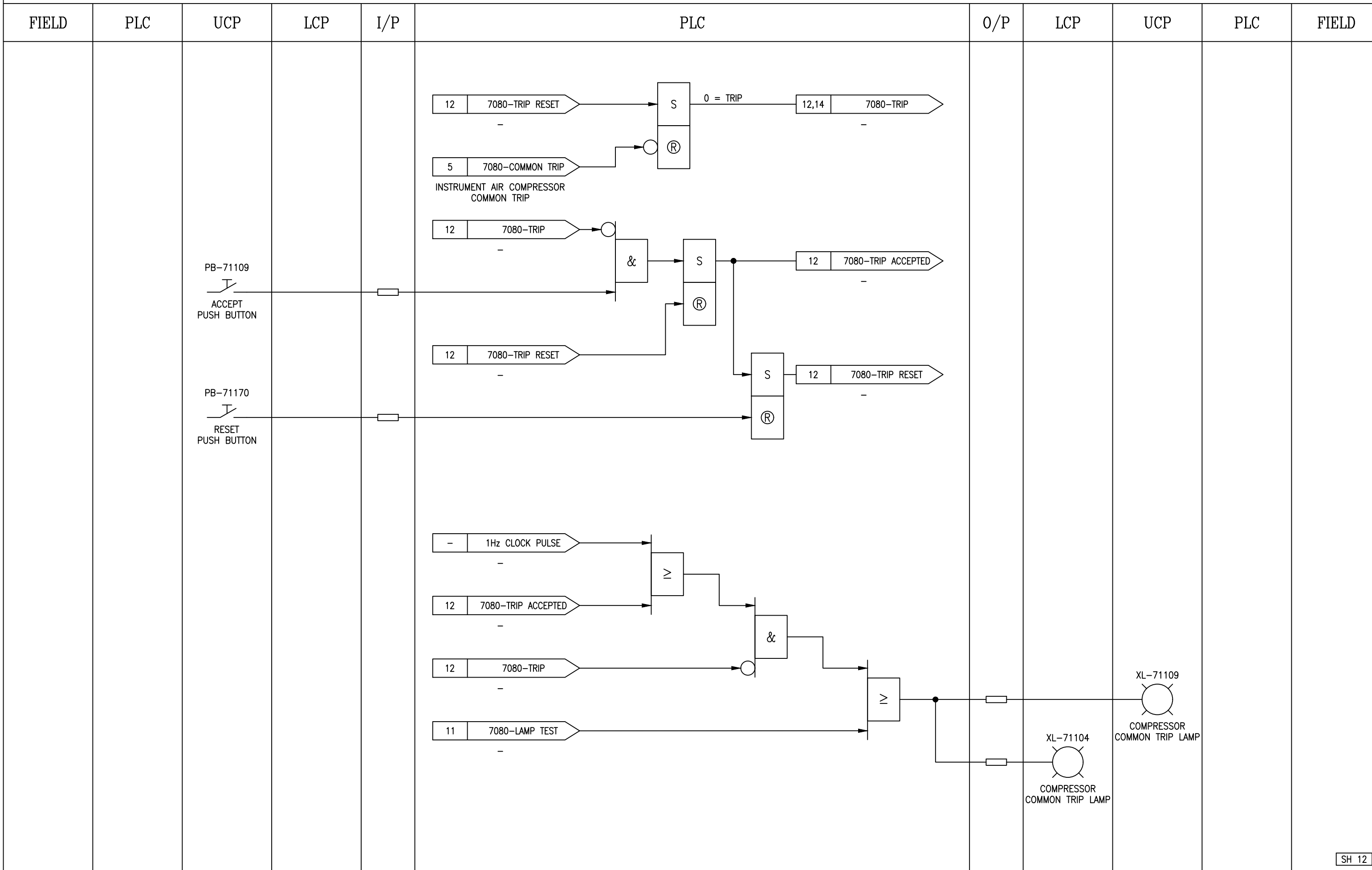

SH 12

NOTES:

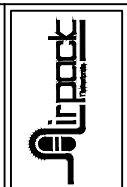

SUBJECT		BUSHEHR PETROCHEMICAL COMPANY MEG PLANT EMERGENCY INSTRUMENT AIR COMPRESSOR	
CLIENT	BUSHEHR PETROCHEMICAL COMPANY (BUPC)	PLANT LOCATION	IRAN
CLIENT REF	20-C-7080	DRAWING NO.	17811-32B
AIRPACK REF	17811	SHEETNO.	12 / 14

DATE	20-11-2020
DRAWN BY	TJ
CHECKED BY	KP

THIS DRAWING IS OWNED BY AIRPACK AND SHALL NOT BE PRINTED OR COPIED IN ANY OTHER WAY THAN WITH AIRPACKS PERMISSION		
REV 05	04-07-2022	RT
REV 04	16-05-2022	WZ
REV 03	18-03-2022	AS
REV 02	03-01-2022	AS
REV 01	29-11-2021	WZ
REV 00	20-11-2020	TJ

LOGIC DIAGRAM

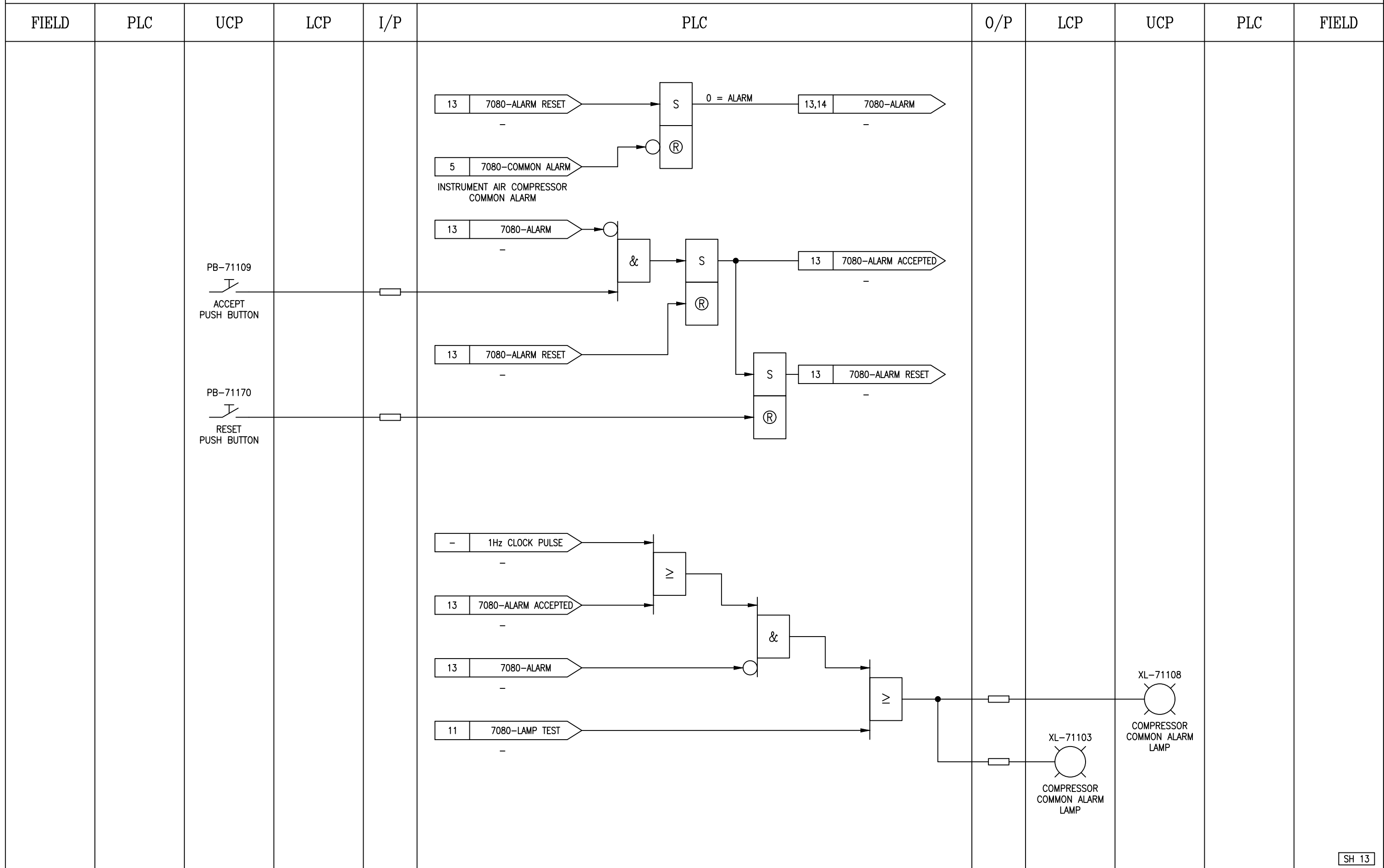

SH 13

NOTES:



SUBJECT BUSHEHR PETROCHEMICAL COMPANY
MEG PLANT
EMERGENCY INSTRUMENT AIR COMPRESSOR

CLIENT BUSHEHR PETROCHEMICAL COMPANY (BUPC)

CLIENT REF 20-C-7080

AIRPACK REF 17811

DATE 20-11-2020

DRAWN BY TJ

CHECKED BY KP

PLANT LOCATION IRAN

DRAWING NO. 17811-32B

SHEETNO. 13 /14

THIS DRAWING IS OWNED BY AIRPACK AND SHALL NOT BE PRINTED OR COPIED IN ANY OTHER WAY THAN WITH AIRPACKS PERMISSION			REV 05	04-07-2022	RT
			REV 04	16-05-2022	WZ
			REV 03	18-03-2022	AS
			REV 02	03-01-2022	AS
			REV 01	29-11-2021	WZ
			REV 00	20-11-2020	TJ

LOGIC DIAGRAM

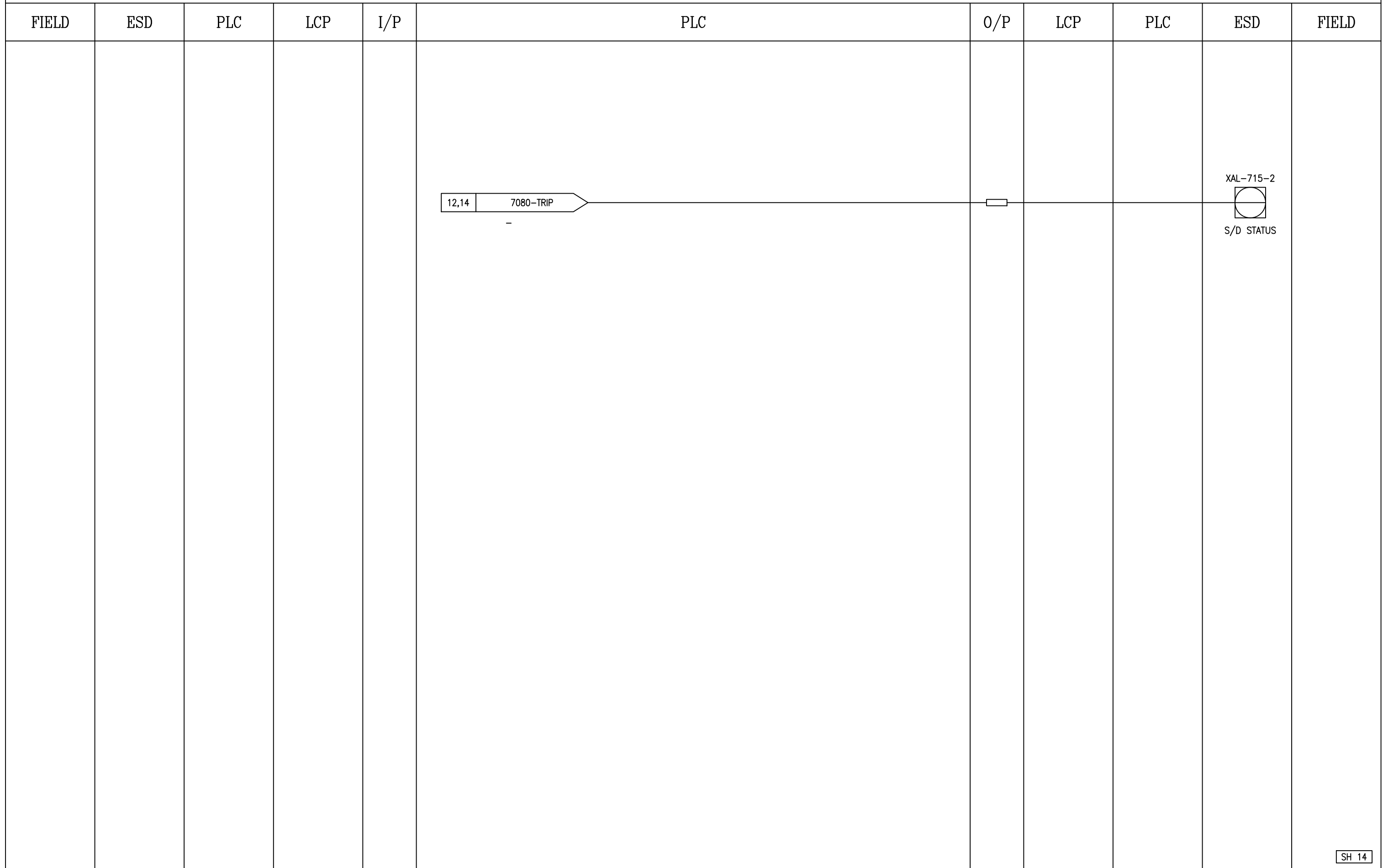

SH 14

NOTES:



SUBJECT		BUSHEHR PETROCHEMICAL COMPANY MEG PLANT EMERGENCY INSTRUMENT AIR COMPRESSOR	
CLIENT	BUSHEHR PETROCHEMICAL COMPANY (BUPC)	PLANT LOCATION	IRAN
CLIENT REF	20-C-7080	DRAWING NO.	17811-32B
AIRPACK REF	17811	SHEETNO.	14 /14

DATE	20-11-2020
DRAWN BY	TJ
CHECKED BY	KP

THIS DRAWING IS OWNED BY AIRPACK AND SHALL NOT BE PRINTED OR COPIED IN ANY OTHER WAY THAN WITH AIRPACKS PERMISSION

REV 05	04-07-2022	RT
REV 04	16-05-2022	WZ
REV 03	18-03-2022	AS
REV02	03-01-2022	AS
REV 01	29-11-2021	WZ
REV 00	20-11-2020	TJ