





OWNER:  شرکت ست و پوی توسعه ایرانیاں (سهانی ٹاس)	<b>BUSHEHR PETROCHEMICAL COMPANY MEG PLANT</b>						EPC CONTRACTOR:  Chagalesh-Enerchimi-Steam Joint Venture BUPC-MEG PLANT PROJECT		
	<b>COMPRESSOR MOTOR OUTLINE DRAWING &amp; TERMINAL BOX WIRING DIAGRAM FOR NITROGEN GAS BOOSTER</b>						 Netherlands		
MC :  شرکت ست و پوی توسعه ایرانیاں (سهانی ٹاس)	Project	Area	Phase	Unit	Dis.	Doc.	Seq.	Contract No: 52-98/445	
Owner Document Number: 17811-39A	BU	20	VD	303	EL	DWG	0053	Rev.:	Page
								04	1 of 5

## COMPRESSOR MOTOR OUTLINE DRAWING & TERMINAL BOX WIRING DIAGRAM FOR NITROGEN GAS BOOSTER

04	05/09/2022	As Built	KP	CL	JR	
03	24/01/2022	Approved for Construction	KP	LdM	JR	
02	06/01/2022	For approval	KP	LdM	JR	
01	10/12/2021	For approval	KP	LdM	JR	
00	08/12/2020	For approval	KP	LdM	JR	
<b>Rev.</b>	<b>Date</b>	<b>Purpose of Issue</b>	<b>Prepared</b>	<b>Checked</b>	<b>Approved</b>	<b>AC Code</b>
					<b>Class: 1</b>	<b>Phase: P</b>



# Nitrogen Gas Booster 20-C-1002-M

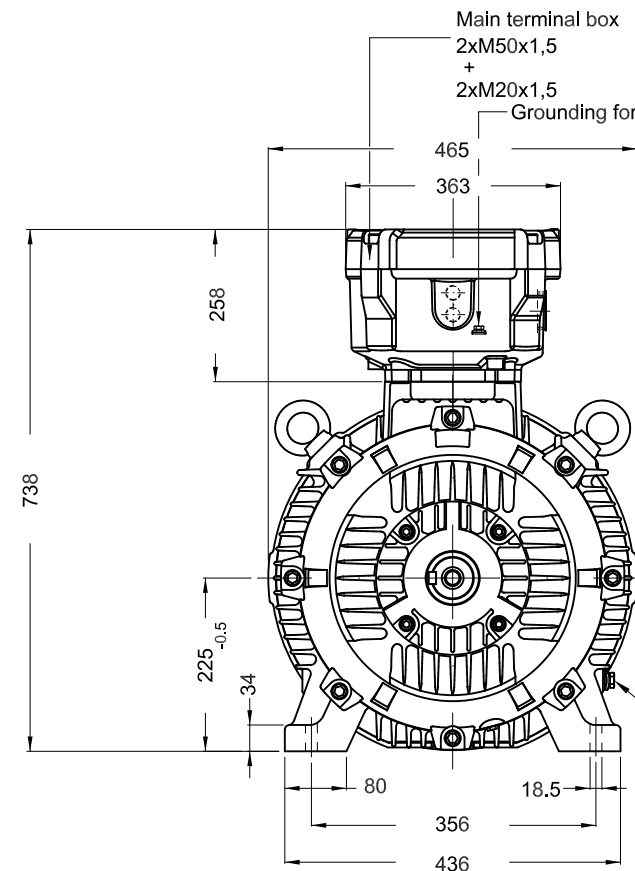

Power Cable Number and Size: **4 x 25 mm<sup>2</sup>**  
 Power Cable Gland and Entries: **1 x M40**  
**Spare entries will be plugged, Airpack will provide a suitable adapter for the cable gland**

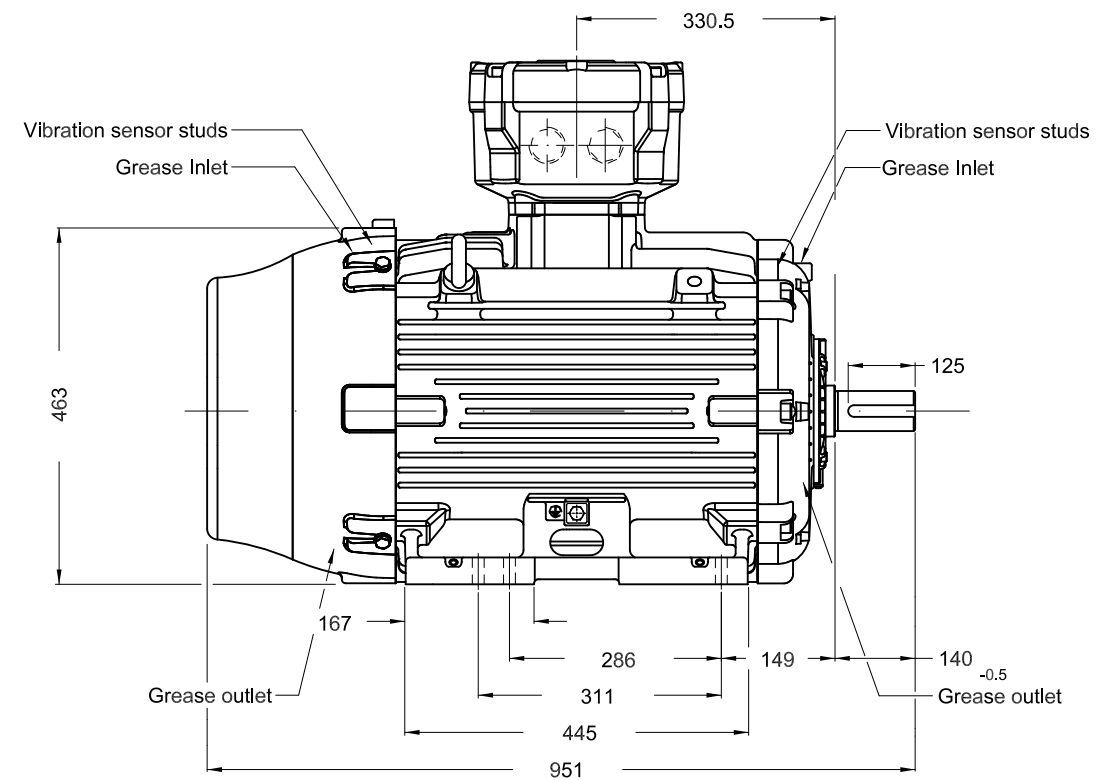

Grounding for leads 25-50 mm<sup>2</sup> / 3-1 AWG  
 Grounding wire of 35mm<sup>2</sup> is suitable for this connection

- Tropicalized internal painting
- DE roller bearing
- Shaft locking device
- Shaft material - AISI/SAE 4140
- SPM studs
- Color RAL 5010
- Painting plan 205P
- Mounting B3T

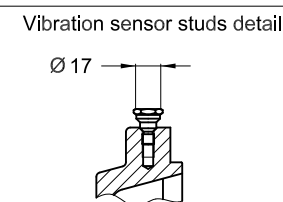
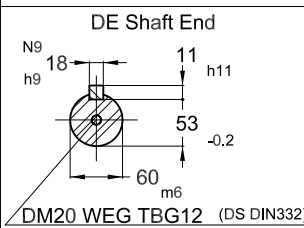

45 kW 04 Poles 50 Hz

Dimensions in mm

ECM	LOC	SUMMARY OF MODIFICATIONS				EXECUTED	CHECKED	RELEASED	DATE	VER
EXECUTED	PIRWBUSER		THREE PH. MOTOR W22Xdb IE4 Ex d IIB T4		PREVIEW	WDD	SHEET	03/05		
CHECKED			FRAME 225S/M IP56 TEFC							
RELEASED			Main Compressor Motor 20-C-1002-M 45kW							
REL DT.			Jaragua do Sul							
		WMO	Product Engineering							

Dimensional drawing subject to change. We reserve the right to change constructional details.  
 \* Detail out of scale.

A



B

C

D

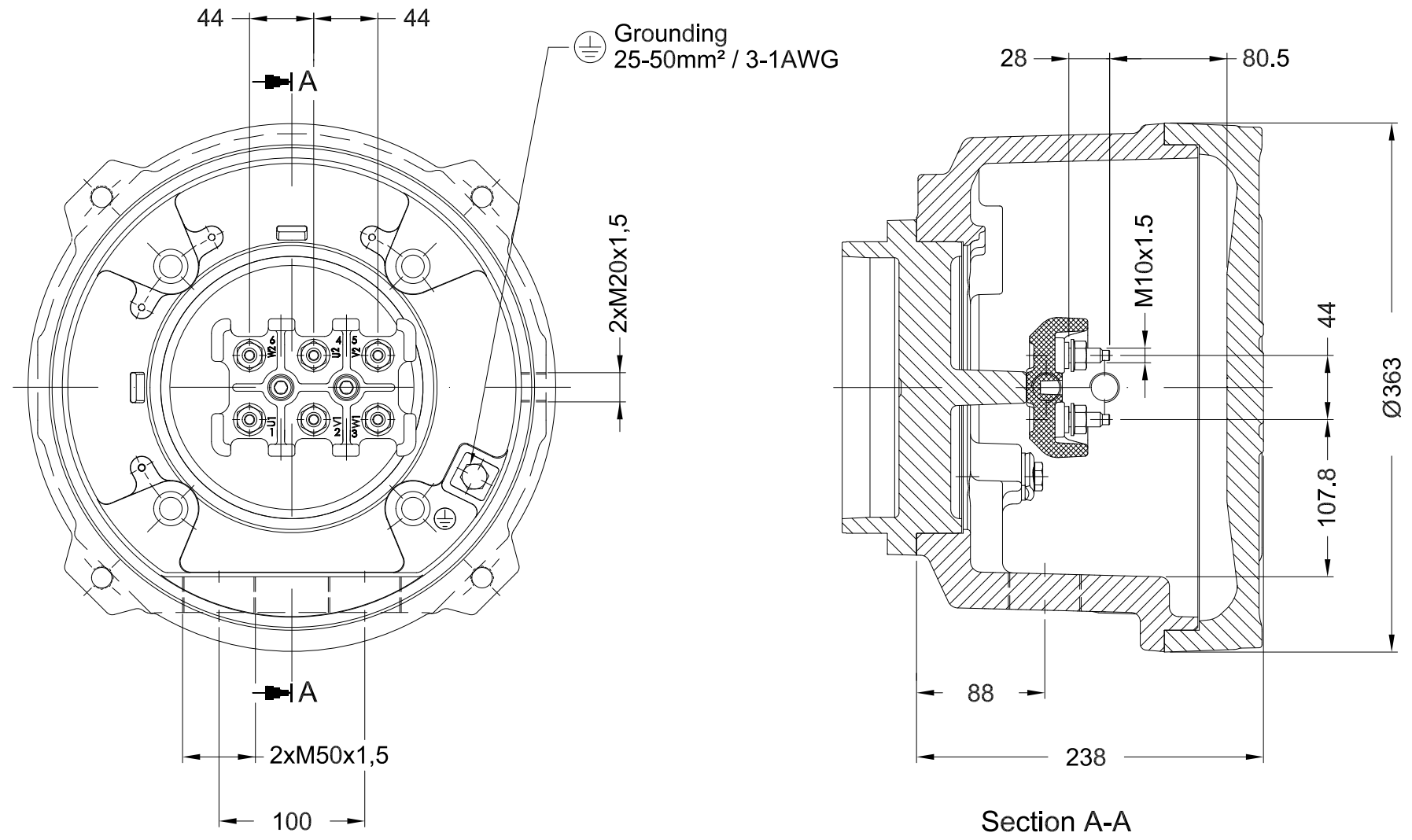
E

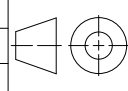

				ESC	1:4				
ECM	LOC	SUMMARY OF MODIFICATIONS		EXECUTED	CHECKED	RELEASED	DATE	VER	
EXECUTED	YDAMHUIS	 MAIN TERMINAL BOX FRAME 225S/M		PREVIEW WCD					
CHECKED								SHEET	04/05
RELEASED									
REL DT.									

THIS IS AN UPDATED REVISION, THE PREVIOUS ONE MUST BE DISREGARDED.

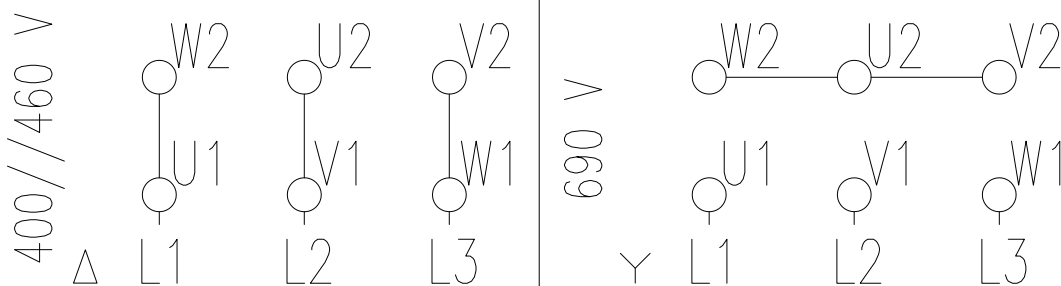

A

B

C

D

E

		ORIGINAL ISSUE		JESSICA	PATRICIA	CASTELLA	30.10.2018	00
ECM	LOC	RESUMO MODIFICAÇÃO		EXECUTADO	VERIFICADO	LIBERADO	DATA	VER
EXEC. /EXECUTED	JESSICA	SUMMARY OF MODIFICATIONS		EXECUTED	CHECKED	RELEASED	DATE	VER
VERIF. /CHECKED	PATRICIA	LOW VOLTAGE - CONNECTION DIAGRAM		400/690//460-6				
LIBER. /RELEASED	CASTELLA	MOTOR WITH 06 CABLES		IEC   00				
DATA LB /REL DT	30.10.2018	WMO	JARAGUÁ DO SUL	ADMINISTRAÇÃO DE VENDAS	FOLHA /SHEET	05/05		